

RESOLUTION NO. 2010- 5

A RESOLUTION BY THE BOARD OF COUNTY COMMISSIONERS OF ST. JOHNS COUNTY, FLORIDA, ACCEPTING A BILL OF SALE FOR THE REGIONAL PUMP STATION UPGRADE IN COQUINA CROSSING SUBDIVISION LOCATED OFF STATE ROAD 207.

RECITALS

WHEREAS, MHC Coquina Crossing, LLC, a Delaware limited liability company has executed and presented to the County a Bill of Sale and schedule of values, attached hereto as Exhibit "A", incorporated by reference and made a part hereof, conveying all personal property associated with the Regional Pump Station upgrade for Coquina Crossing Subdivision located off State Road 207; and

WHEREAS, St. Johns County Utility Department has reviewed and approved the document mentioned above, as stated in a memo attached hereto as Exhibit "B", incorporated by reference and made a part hereof; and

WHEREAS, to the extent that there are typographical, scrivener or administrative errors that do not change the tone, tenor, or concept of this Resolution, then this Resolution may be revised without subsequent approval by the Board of County Commissioners.

NOW, THEREFORE BE IT RESOLVED BY THE BOARD OF COUNTY COMMISSIONERS OF ST. JOHNS COUNTY, FLORIDA, as follows:

Section 1. The above recitals are incorporated by reference into the body of this Resolution and such recitals are adopted as findings of fact.

Section 2. The above described Bill of Sale attached and incorporated hereto, is hereby accepted by the Board of County Commissioners.

Section 3. The Clerk of the Circuit Court is instructed to file the Bill of Sale in the Public Records of St. Johns County, Florida.

PASSED AND ADOPTED this 19th day of January, 2010.

**BOARD OF COUNTY COMMISSIONERS
ST. JOHNS COUNTY, FLORIDA**

By: Ron Sanchez
Ron Sanchez, Chair

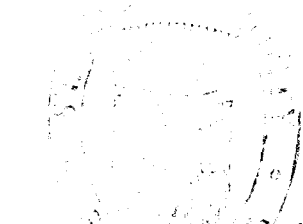

ATTEST: Cheryl Strickland, Clerk

By: Pam Halterman
Deputy Clerk

RENDITION DATE 1/20/10

BILL OF SALE

**UTILITY IMPROVEMENTS
FOR COQUINA CROSSING PUD**

Page 1

MHC Coquina Crossing, L.L.C., located in Elkton, Florida 32033, for and in consideration of the sum of ten and No/100 Dollars (\$10.00) and other good and valuable consideration, the receipt and sufficiency of which is hereby acknowledged, hereby grants, bargains, sells, transfers and delivers to **ST. JOHNS COUNTY, FLORIDA**, a political subdivision of the State of Florida, the following personal property:

The personal property, fixtures and equipment comprising the Coquina Crossing Regional Pump Station Upgrade, (the "Improvements"), for improvements within the project. All of the improvements are included on the approved construction plan drawing (C-15), prepared by Eisman & Russo, Inc., titled "Coquina Crossing Regional Pump Station Upgrade" marked "Approved" by St. Johns County on July 28, 2003 (the "Plan"). All of the improvements are lying within the pump station site at 4840 Coquina Crossing Drive, a part of Coquina Crossing PUD, recorded in Map Book 1811 Pages 11 through 32 of the public records of St. Johns County, Florida. Said personal property, fixtures and equipment being more particularly described on Exhibit A (the Plan) and Exhibit B (Schedule of Values).

MHC Coquina Crossing, L.L.C. does for itself and its successors and assigns, covenant to and with St. Johns County and its successors and assigns, that it is the lawful owner of said personal property, that the personal property is free of all encumbrances; that it has good right to sell the same; and that it will warrant and defend the sale of the personal property against the lawful claims and demands of all persons.

IN WITNESS THEREOF, MHC Coquina Crossing, L.L.C. has caused this instrument to be duly executed and delivered by its duly authorized officer on this 28th day of March, 2005.

MHC COQUINA CROSSING, L.L.C.

By: David W. Fell
Title: Vice President

Print: David W. Fell

WITNESS

Liz McNair
Title: 0

Print: LIZ MCNAIR

BILL OF SALE

**UTILITY IMPROVEMENTS
FOR COQUINA CROSSING PUD**

Page 2

STATE OF ILLINOIS

COUNTY OF COOK

BEFORE ME, the undersigned authority, this day personally appeared DAVID W. FELL, well known to me to be the individual who acknowledged that he executed the foregoing document for the uses and purposes described herein.

WITNESS my hand and official seal this 28th day of MARCH, 2005.

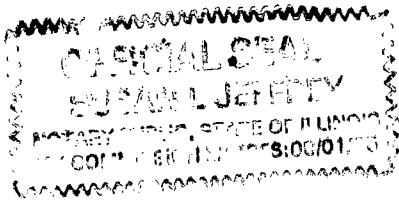

Susan L. Jeffrey

Notary Public, State of Illinois

My Commission expires: 03/01/05

© 1995 THIS DRAWING IS THE INSTRUMENT OF SERVICE AND PROPERTY OF EISMAN & RUSSO, INC. ANY USE OR REPRODUCTION WITHOUT THE EXPRESSED WRITTEN PERMISSION OF THIS CORPORATION IS PROHIBITED. ALL RIGHTS OF DESIGN AND INVENTION ARE EXPRESSLY RESERVED.

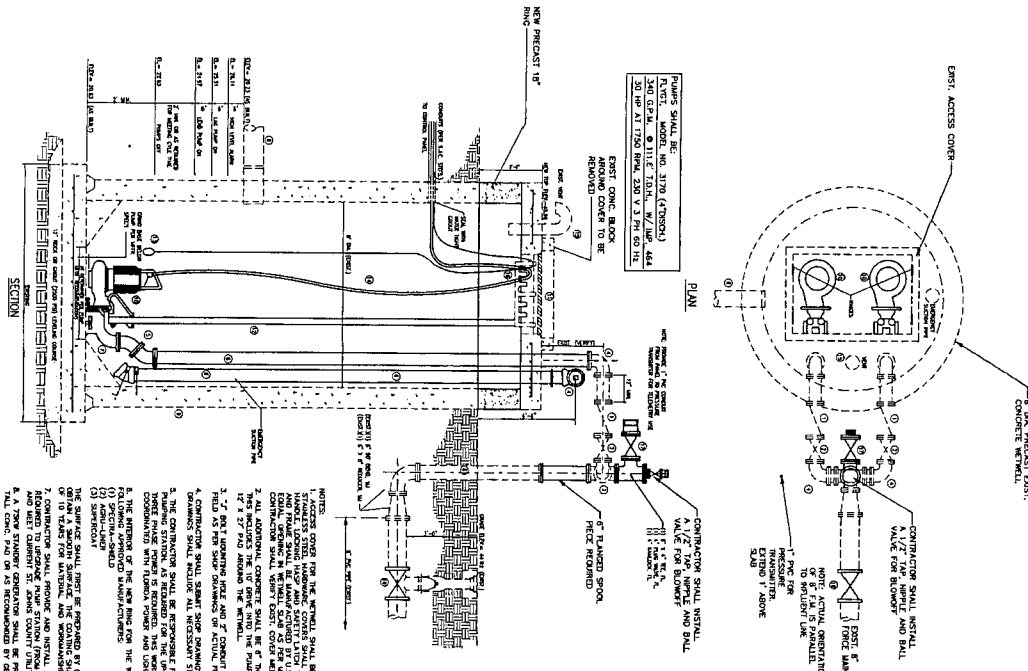

- MECHANICAL EQUIPMENT SCHEDULE**
1. CAST IN PLACE CONCRETE FOR THE GENERATOR PAD AND STAIRS
 2. 1/2" PLAC W/4% S.S. CAST IN PLACE CONCRETE
 3. 1/2" PLAC W/4% S.S. CAST IN PLACE CONCRETE
 4. 1/2" PLAC W/4% S.S. CAST IN PLACE CONCRETE
 5. 1/2" PLAC W/4% S.S. CAST IN PLACE CONCRETE
 6. 1/2" PLAC W/4% S.S. CAST IN PLACE CONCRETE
 7. 1/2" PLAC W/4% S.S. CAST IN PLACE CONCRETE
 8. 1/2" PLAC W/4% S.S. CAST IN PLACE CONCRETE
 9. 1/2" PLAC W/4% S.S. CAST IN PLACE CONCRETE
 10. 1/2" PLAC W/4% S.S. CAST IN PLACE CONCRETE
 11. ALUMINUM METALLIC ACCESS COVER (OPTIONAL PER PUMP MANUFACTURER) (EXIST)
 12. STAINLESS STEEL GROUND RAILS
 13. LEVEL TRANSPOSCERS PROVIDED BY PUMP MANUF.
 14. PUMP MOTOR COUPLER
 15. 4" NEW FIBER OPTIC CABLE TO THE PUMP MANUFACTURER (EXIST)
 16. STAINLESS STEEL COUPLER HOUSING
 17. 1/2" PLAC W/4% S.S. CAST IN PLACE CONCRETE
 18. 1/2" PLAC W/4% S.S. CAST IN PLACE CONCRETE
 19. 1/2" PLAC W/4% S.S. CAST IN PLACE CONCRETE

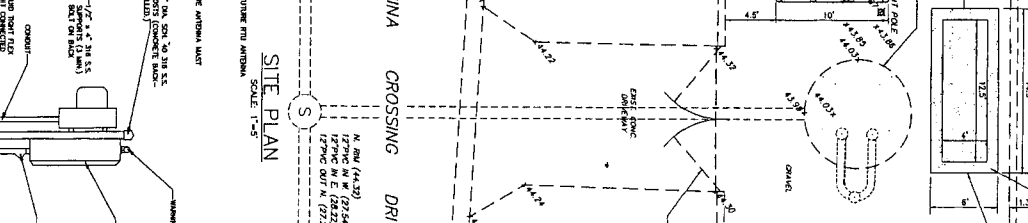
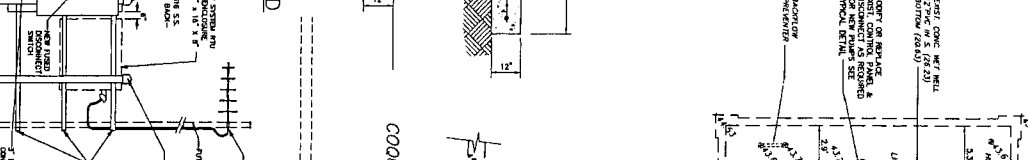
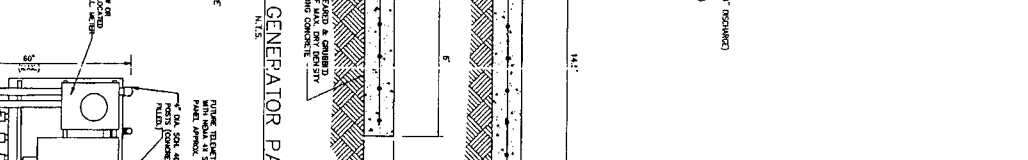
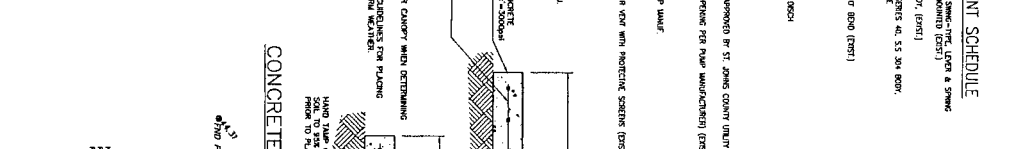

AS-BUILT

REVISIONS:

NO.	DATE	BY	REVISION DESCRIPTION
1	11/17/02	GLK	REV. ISSUE
2	11/17/02	GLK	REV. ISSUE
3	11/17/02	GLK	REV. ISSUE
4	11/17/02	GLK	REV. ISSUE
5	11/17/02	GLK	REV. ISSUE
6	11/17/02	GLK	REV. ISSUE
7	3/22/05	USA, GLK	AS-BUILT DRAWING

EISMAN & RUSSO Engineers, Architects, Planners, Inc.

1400 W. 10th Street, Suite 100, Fort Lauderdale, FL 33304

TEL: 954-574-1111 FAX: 954-574-1112

PROJECT NO. 0000000000

DATE: 3/22/05

COQUINA CROSSING 1 REGIONAL PUMP STATION UPGRADE

REVISED GENERATOR PLAN SUBMITTAL NO. 3

CONSTRUCTION PLAN SUBMITTAL NO. 3

REVISED GENERATOR PLAN SUBMITTAL NO. 2

CONSTRUCTION PLAN SUBMITTAL NO. 2

REVISED GENERATOR PLAN SUBMITTAL NO. 1

CONSTRUCTION PLAN SUBMITTAL NO. 1

REGULATION PROVIDED BY:
 STATE OF CALIFORNIA
 PUBLIC UTILITY REGULATORY COMMISSION
 DIVISION OF WATER RESOURCES
 1401 STREET, SACRAMENTO, CA 95833
 TEL: (916) 227-1234
 FAX: (916) 227-1234
 WWW.PUC.CA.GOV

REGULATION PROVIDED BY:
 STATE OF CALIFORNIA
 PUBLIC UTILITY REGULATORY COMMISSION
 DIVISION OF WATER RESOURCES
 1401 STREET, SACRAMENTO, CA 95833
 TEL: (916) 227-1234
 FAX: (916) 227-1234
 WWW.PUC.CA.GOV

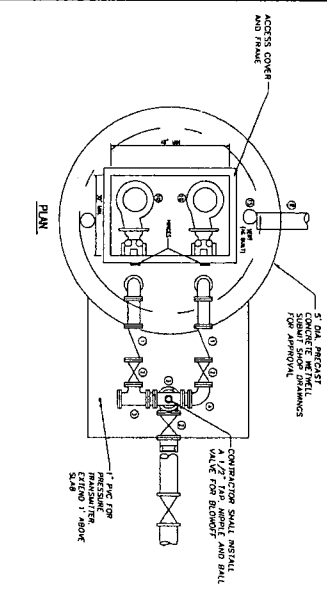
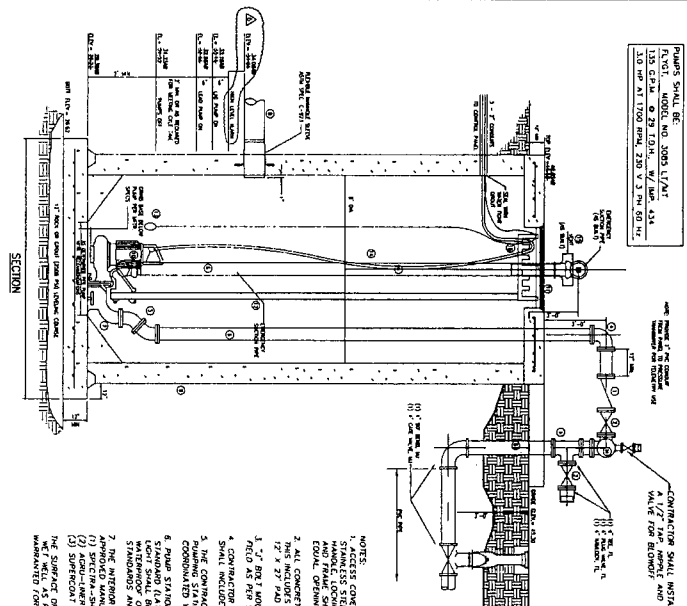

- ### MECHANICAL EQUIPMENT SCHEDULE
1. 1" DIA. METALLIC CONCRETE W/REINFORCING FOR JUNCTION
 2. 4" DIA. W/REINFORCING CONCRETE FOR W/REINFORCING
 3. 4" DIA. W/REINFORCING CONCRETE FOR W/REINFORCING
 4. 4" DIA. W/REINFORCING CONCRETE FOR W/REINFORCING
 5. 4" DIA. W/REINFORCING CONCRETE FOR W/REINFORCING
 6. 4" DIA. W/REINFORCING CONCRETE FOR W/REINFORCING
 7. 4" DIA. W/REINFORCING CONCRETE FOR W/REINFORCING
 8. 4" DIA. W/REINFORCING CONCRETE FOR W/REINFORCING
 9. 4" DIA. W/REINFORCING CONCRETE FOR W/REINFORCING
 10. 4" DIA. W/REINFORCING CONCRETE FOR W/REINFORCING
 11. 4" DIA. W/REINFORCING CONCRETE FOR W/REINFORCING
 12. 4" DIA. W/REINFORCING CONCRETE FOR W/REINFORCING
 13. 4" DIA. W/REINFORCING CONCRETE FOR W/REINFORCING
 14. 4" DIA. W/REINFORCING CONCRETE FOR W/REINFORCING
 15. 4" DIA. W/REINFORCING CONCRETE FOR W/REINFORCING
 16. 4" DIA. W/REINFORCING CONCRETE FOR W/REINFORCING
 17. 4" DIA. W/REINFORCING CONCRETE FOR W/REINFORCING
 18. 4" DIA. W/REINFORCING CONCRETE FOR W/REINFORCING

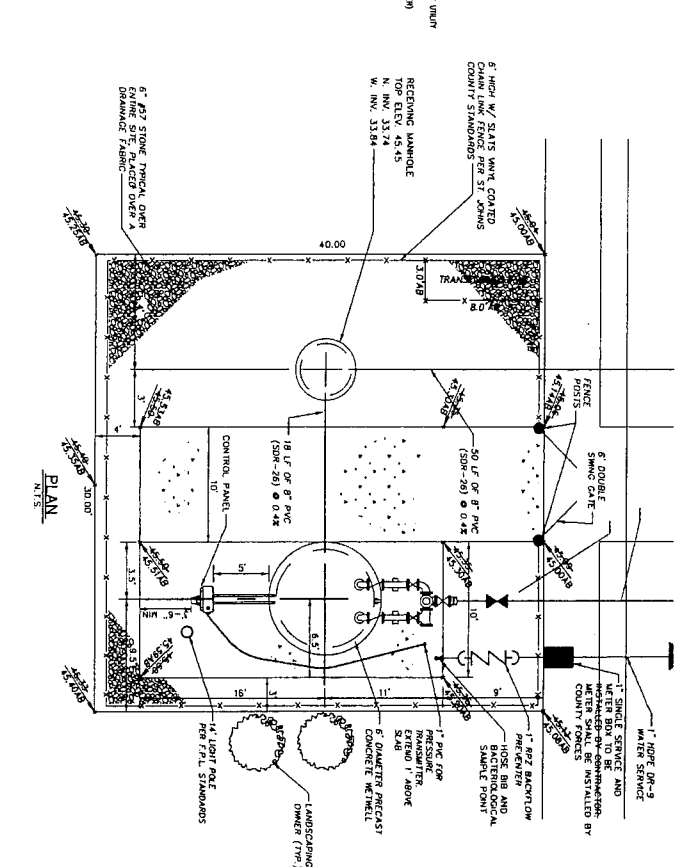
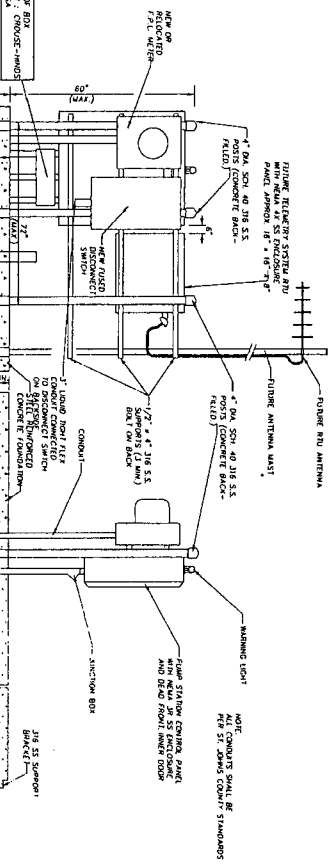

AS-BUILT

COOUNA CROSSING PHASE TWO PUMP STATION DETAILS

NO.	DATE	DESCRIPTION
1	11/15/12	ISSUE FOR PERMITS
2	02/22/13	ISSUE FOR CONSTRUCTION
3	03/15/13	ISSUE FOR CONSTRUCTION
4	03/28/13	ISSUE FOR CONSTRUCTION
5	04/11/13	ISSUE FOR CONSTRUCTION
6	04/24/13	ISSUE FOR CONSTRUCTION
7	05/07/13	ISSUE FOR CONSTRUCTION
8	05/20/13	ISSUE FOR CONSTRUCTION
9	06/03/13	ISSUE FOR CONSTRUCTION
10	06/16/13	ISSUE FOR CONSTRUCTION
11	06/29/13	ISSUE FOR CONSTRUCTION
12	07/12/13	ISSUE FOR CONSTRUCTION
13	07/25/13	ISSUE FOR CONSTRUCTION
14	08/08/13	ISSUE FOR CONSTRUCTION
15	08/21/13	ISSUE FOR CONSTRUCTION
16	09/04/13	ISSUE FOR CONSTRUCTION
17	09/17/13	ISSUE FOR CONSTRUCTION
18	09/30/13	ISSUE FOR CONSTRUCTION
19	10/13/13	ISSUE FOR CONSTRUCTION
20	10/26/13	ISSUE FOR CONSTRUCTION
21	11/09/13	ISSUE FOR CONSTRUCTION
22	11/22/13	ISSUE FOR CONSTRUCTION
23	12/06/13	ISSUE FOR CONSTRUCTION
24	12/19/13	ISSUE FOR CONSTRUCTION
25	01/02/14	ISSUE FOR CONSTRUCTION
26	01/15/14	ISSUE FOR CONSTRUCTION
27	01/28/14	ISSUE FOR CONSTRUCTION
28	02/11/14	ISSUE FOR CONSTRUCTION
29	02/24/14	ISSUE FOR CONSTRUCTION
30	03/09/14	ISSUE FOR CONSTRUCTION
31	03/22/14	ISSUE FOR CONSTRUCTION
32	04/05/14	ISSUE FOR CONSTRUCTION
33	04/18/14	ISSUE FOR CONSTRUCTION
34	05/01/14	ISSUE FOR CONSTRUCTION
35	05/14/14	ISSUE FOR CONSTRUCTION
36	05/27/14	ISSUE FOR CONSTRUCTION
37	06/09/14	ISSUE FOR CONSTRUCTION
38	06/22/14	ISSUE FOR CONSTRUCTION
39	07/06/14	ISSUE FOR CONSTRUCTION
40	07/19/14	ISSUE FOR CONSTRUCTION
41	08/01/14	ISSUE FOR CONSTRUCTION
42	08/14/14	ISSUE FOR CONSTRUCTION
43	08/27/14	ISSUE FOR CONSTRUCTION
44	09/09/14	ISSUE FOR CONSTRUCTION
45	09/22/14	ISSUE FOR CONSTRUCTION
46	10/06/14	ISSUE FOR CONSTRUCTION
47	10/19/14	ISSUE FOR CONSTRUCTION
48	11/01/14	ISSUE FOR CONSTRUCTION
49	11/14/14	ISSUE FOR CONSTRUCTION
50	11/27/14	ISSUE FOR CONSTRUCTION
51	12/10/14	ISSUE FOR CONSTRUCTION
52	12/23/14	ISSUE FOR CONSTRUCTION
53	01/06/15	ISSUE FOR CONSTRUCTION
54	01/19/15	ISSUE FOR CONSTRUCTION
55	02/01/15	ISSUE FOR CONSTRUCTION
56	02/14/15	ISSUE FOR CONSTRUCTION
57	02/26/15	ISSUE FOR CONSTRUCTION
58	03/11/15	ISSUE FOR CONSTRUCTION
59	03/24/15	ISSUE FOR CONSTRUCTION
60	04/07/15	ISSUE FOR CONSTRUCTION
61	04/20/15	ISSUE FOR CONSTRUCTION
62	05/04/15	ISSUE FOR CONSTRUCTION
63	05/17/15	ISSUE FOR CONSTRUCTION
64	05/30/15	ISSUE FOR CONSTRUCTION
65	06/12/15	ISSUE FOR CONSTRUCTION
66	06/25/15	ISSUE FOR CONSTRUCTION
67	07/09/15	ISSUE FOR CONSTRUCTION
68	07/22/15	ISSUE FOR CONSTRUCTION
69	08/05/15	ISSUE FOR CONSTRUCTION
70	08/18/15	ISSUE FOR CONSTRUCTION
71	08/31/15	ISSUE FOR CONSTRUCTION
72	09/13/15	ISSUE FOR CONSTRUCTION
73	09/26/15	ISSUE FOR CONSTRUCTION
74	10/09/15	ISSUE FOR CONSTRUCTION
75	10/22/15	ISSUE FOR CONSTRUCTION
76	11/05/15	ISSUE FOR CONSTRUCTION
77	11/18/15	ISSUE FOR CONSTRUCTION
78	12/01/15	ISSUE FOR CONSTRUCTION
79	12/14/15	ISSUE FOR CONSTRUCTION
80	12/27/15	ISSUE FOR CONSTRUCTION
81	01/09/16	ISSUE FOR CONSTRUCTION
82	01/22/16	ISSUE FOR CONSTRUCTION
83	02/04/16	ISSUE FOR CONSTRUCTION
84	02/17/16	ISSUE FOR CONSTRUCTION
85	02/29/16	ISSUE FOR CONSTRUCTION
86	03/13/16	ISSUE FOR CONSTRUCTION
87	03/26/16	ISSUE FOR CONSTRUCTION
88	04/08/16	ISSUE FOR CONSTRUCTION
89	04/21/16	ISSUE FOR CONSTRUCTION
90	05/04/16	ISSUE FOR CONSTRUCTION
91	05/17/16	ISSUE FOR CONSTRUCTION
92	05/30/16	ISSUE FOR CONSTRUCTION
93	06/11/16	ISSUE FOR CONSTRUCTION
94	06/24/16	ISSUE FOR CONSTRUCTION
95	07/07/16	ISSUE FOR CONSTRUCTION
96	07/20/16	ISSUE FOR CONSTRUCTION
97	08/02/16	ISSUE FOR CONSTRUCTION
98	08/15/16	ISSUE FOR CONSTRUCTION
99	08/28/16	ISSUE FOR CONSTRUCTION
100	09/10/16	ISSUE FOR CONSTRUCTION

EISMAN & RUSSO
 ENGINEERS
 10100 WILSON AVENUE, SUITE 200
 WESTLAKE, CALIFORNIA 91361
 TEL: (818) 717-7777
 FAX: (818) 717-7778
 WWW.EISMANANDRUSSO.COM

PROJECT NO. 2009-020
 DRAWING NO. C-13
 SHEET NO. 11 OF 11
 8/4/2017

COQUINA CROSSING REGIONAL WASTEWATER PUMPING STATION IMPROVEMENTS

SCHEDULE OF VALUES

SUBCON2003000006

WASTEWATER PUMPING STATION IMPROVEMENTS:	\$127,305.00
STANDBY GENERATOR SET:	<u>\$44,501.00</u>
TOTAL VALUE:	\$171,806.00

St. Johns County Board of County Commissioners

UTILITY DEPARTMENT
Engineering Division

1205 STATE ROAD 16
SAINT AUGUSTINE, FLORIDA
32084-8646

PHONE: (904) 209-2700
FAX: (904) 209-2601

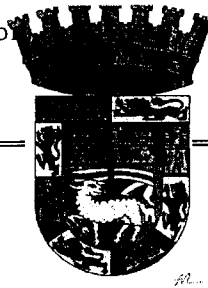

INTEROFFICE MEMORANDUM

TO: NANETTE BRADBURY, REAL ESTATE COORDINATOR
FROM: MELISSA CARAWAY, UTILITY REVIEW COORD., ENGINEERING
THROUGH: ROBERT ZAMMATARO, CHIEF ENGINEER - DEVELOPMENT
SUBJECT: BILL OF SALE - COQUINA CROSSING REGIONAL PUMP STATION
DATE: DECEMBER 11, 2009

Please present the Bill of Sale documents to the Board of County Commissioners (BCC) for final approval and acceptance of the Coquina Crossing Regional Pump Station.

After acceptance by BCC, please provide the utility department with a copy of the executed resolution and a copy of the Bill of Sale for our files.

Your support and cooperation as always are greatly appreciated.