

RESOLUTION NO. 2014 - 270

A RESOLUTION BY THE BOARD OF COUNTY COMMISSIONERS OF ST. JOHNS COUNTY, FLORIDA, AUTHORIZING THE COUNTY ADMINISTRATOR, OR DESIGNEE, TO AWARD BID NO. 14-105 AND TO EXECUTE AN AGREEMENT FOR MARSH LANDING WWTP INFLUENT PUMP STATION AND STATIC SCREEN IMPROVEMENTS

RECITALS

WHEREAS, the County desires to enter into a contract with Sawcross, Inc. to provide services for construction of Marsh Landing WWTP Influent Pump Station and Static Screen Improvements; and

WHEREAS, the scope of the project shall generally include furnishing all labor, materials, equipment and other items necessary for influent pump station and static screen improvements; and

WHEREAS, through the County's formal bid process, Sawcross, Inc. was selected as the most qualified respondent to enter into a contract with the County to perform the work referenced above; and

WHEREAS, the County has reviewed the terms, provisions, conditions and requirements of the proposed contract (attached hereto and incorporated herein), and finds that entering into the contract serves a public purpose.

BE IT RESOLVED BY THE BOARD OF COUNTY COMMISSIONERS OF ST. JOHNS COUNTY, FLORIDA:

Section 1. The above Recitals are incorporated by reference into the body of this Resolution and such Recitals are adopted as finds of fact.

Section 2. The County Administrator, or his designee, is hereby authorized to award Bid No.14-105 Marsh Landing WWTP Influent Pump Station and Static Screen Improvements to Sawcross, Inc. as the lowest responsive, responsible bidder.

Section 3. The County Administrator, or his designee, is further authorized to execute a contract in substantially the same form and format as attached with Sawcross, Inc. on behalf of the County for the completion of the Marsh Landing WWTP Influent Pump Station and Static Screen Improvements as specifically provided in Bid No 14-105.

Section 4. To the extent that there are typographical or administrative errors that do not change the tone, tenor, or concept of this Resolution, then this Resolution may be revised without subsequent approval by the Board of County Commissioners.

PASSED AND ADOPTED by the Board of County Commissioners of St. Johns County, Florida, this 11th day of October, 2014.

**BOARD OF COUNTY COMMISSIONERS
OF ST. JOHNS COUNTY, FLORIDA**

By: [Signature]
John H. Morris - Chair

ATTEST, Cheryl Strickland, Clerk

By: [Signature]
Deputy Clerk

RENDITION DATE 10/10/14



**ST. JOHNS COUNTY
PURCHASING DEPARTMENT**

500 San Sebastian View
St. Augustine, Florida 32084

I N T E R O F F I C E M E M O R A N D U M

TO: Scott Trigg, PE, Chief Engineer
FROM: Sharon Haluska, Contract Manager 
SUBJECT: Transmittal of Bids Received for Bid No. 14-105, Marsh Landing WWTP Influent
Pump Station and Static Screens Improvements
DATE: September 10, 2014

Attached are copies of the bid proposals received for the above mentioned along with a copy of the Bid Tabulation Sheet.

Please review, evaluate and make a written recommendation for this project. Also, indicate the budgeted amount for this item along with the appropriate charge code and return at your earliest convenience. We will prepare the agenda item and contract.

Please let me know if I can assist your department in any other way.

Dept. Approval Scott Trigg
Date 9/12/14
Budget Amount \$605,000.00
Account Funding Title Marsh Landing WWTP Influent PS & Screen
Funding Charge Code 4459-56302-6880-56302
Award to Sawcross, Inc
Award Amount \$603,000.00

**ST. JOHNS COUNTY
BID TABULATION**

LEIGH DANIELS
YVETTE CANDLER *yc*

OPENED BY
TABULATED BY
VERIFIED BY

ANY BIDDER AFFECTED ADVERSELY BY AN INTENDED
DECISION WITH RESPECT TO THE AWARD OF ANY BID,
SHALL FILE WITH THE PURCHASING DEPARTMENT FOR
ST. JOHNS COUNTY, A WRITTEN NOTICE OF OF INTENT
FILE A PROTEST NOT LATER THAN SEVENTY-TWO (72)
HOURS (EXCLUDING SATURDAY, SUNDAY AND LEGAL
HOLIDAYS) AFTER THE POSTING OF THE BID TABULATION
PROTEST PROCEDURES MAY BE OBTAINED IN THE
PURCHASING DEPARTMENT.

BID TITLE: MARSH LANDING WWTP INFLUENT PUMP STATION AND
STATIC SCREENS IMPROVEMENTS

BID NUMBER: 14-105

OPENING DATE/TIME: September 10, 2014 2:00 PM

FROM: 09/10/14 3:00 PM UNTIL: 09/15/14 3:00 PM

POSTING DATE/TIME: 09/10/14 3:00 PM

BIDDERS	TOTAL LUMP SUM BID PRICE	BID BOND	ADDENDUM # 1	ADDENDUM # 2	ADDENDUM # 3
SAWCROSS INC	\$603,000.00	YES	YES	YES	YES
R.B. GAY CONSTRUCTION CO INC	\$661,748.00	YES	YES	YES	YES

BID AWARD DATE -

BID PROPOSAL SUMMARY

BID NO.: 14-105 - Marsh Landing WWTP Influent Pump Station and Static Screens Improvements												
COMPANY NAME	Attachments						Licenses/Cer ts	ADDENDUM 1, 2, 3	Bid	Notes		
	BID PRICE	A	B	C	D	E					F	
Sawcross, Inc.	\$603,000.00	X	X	X	X	X	X	X	X	Bond	Bid proposal is responsive & contractor meets the qualifications required.	
R. B. Gay Construction Co., Inc.	\$661,748.00	X	X	X	X	X	X	X	X		Bid proposal is responsive & contractor meets the qualifications required.	

BID NO.: 14-105

NOTICE TO BIDDERS – CONSTRUCTION

Notice is hereby given that sealed bids will be received **until 2:00 P.M.** on **Wednesday, September 10, 2014**, St. Johns County Purchasing Dept. located in the St. Johns Co Administration Bldg at **500 San Sebastian View, St. Augustine, Florida 32084** (904) 209-0150 for construction of the **Marsh Landing WWTP Influent Pump Station & Static Screen Improvements**. Bids will be opened promptly after the 2:00 P.M. deadline. **Note:** Bids must be delivered or received in the Purchasing Department by the 2:00 P.M. deadline.

Scope of Work:

The scope of work for this project shall include furnishing all labor, materials, equipment and any other items necessary for demolition of an existing lined influent wastewater surge pond and existing influent static screen slab on grade, construction of a new elevated influent wastewater static screen and base structure, relocation of an existing static screen to a newly constructed slab on grade adjacent to the new screen and structure, construction of a new wet well and triplex submersible influent pump station, installation of pipes, valves, and appurtenances, removal and replacement of existing ductile iron aeration piping with stainless steel piping, electrical, SCADA, and instrumentation and controls for the work described, site restoration including filling the pond to proposed grade, grassing, and other restoration. All work shall be performed in accordance with the plans and specifications.

There will be a **Non-Mandatory** Pre-Bid Conference on **Wednesday, August 20, 2014 at 9:30 a.m.** at St. Johns County Utility Dept., 1205 State Road 16, St. Augustine, FL 32013. A site visit will be conducted following the meeting for those interested. Interested bidders are highly encouraged to receive and review the bid documents PRIOR to the meeting and be prepared with questions.

Minimum Qualifications: Prime bidders must be fully licensed to conduct business in the State of Florida and hold either a Certified General Contractor or Underground Utility Contractor license at the time the bid is submitted. The submitting company must have business under the bidding company name for five (5) years and have successfully constructed a minimum of three (3) similar projects in the past five (5) years of the same type, size and dollar value of the project proposed in this bid. Proof of licensing and prior experience must be submitted with the bid.

Copies of Bidding Documents shall be obtained via Email request for **Bid No 14-105 Marsh Landing WWTP Influent Pump Station & Static Screen Improvements** along with full company name, address, phone & fax numbers, primary contact name to Sharon Haluska at shaluska@sjcfl.us.

Additionally, document orders may be facilitated through Onvia DemandStar, Inc. These requests will be forwarded to the party responsible for bid document distribution via email. For technical assistance with this Website please contact Onvia Supplier Services at 1-800-711-1712. A link to Onvia DemandStar is also available through the St. Johns County Website at www.sjcfl.us/BCC/Purchasing/Open_Bids.aspx. Check the County's site for download availability and any applicable fees. Vendors registered with Onvia DemandStar.com may visit www.demandstar.com to electronically download some documents.

Any and all technical questions relative to this project shall be directed **in writing** to Teri Pinson, SJCUD Project Manager via email to tpinson@sjcfl.us. Any and all procurement or bid process questions shall be directed **in writing** to Sharon Haluska, SJC Purchasing via email to shaluska@sjcfl.us. **All questions must be received by the designated contacts on or before 4:00 P.M., Thursday, August 27, 2014.**

Designated Points of Contact:

1. Teri Pinson, SJCUD Project Manager, tpinson@sjcfl.us
2. Sharon Haluska, SJC Purchasing Dept. (904) 209-0156 at shaluska@sjcfl.us

Vendors shall not contact, lobby, or otherwise communicate with any SJC employee, including any member of the Board of County Commissioners, other than the above referenced individual from the point of advertisement of the Bid until contract(s) are executed by all parties, per SJC Purchasing Code 304.6.5 "Procedures Concerning Lobbying". According to SJC policy, any such communication shall disqualify the vendor, contractor, or consultant from responding to the subject invitation to bid, request for quote, request for proposal, invitation to negotiate, or request for qualifications.

Any bidder, proposer or person substantially and adversely affected by an intended decision or by an term, condition, procedure or specification with respect to any bid, invitation, solicitation of proposals or requests for qualifications, shall file with the Purchasing Department for St. Johns County, a written notice of intent to protest no later than 72 hours (excluding Saturdays, Sundays and legal holidays for employees of St. Johns County) after the posting either electronically or by other means of the notice of intended action, not of intended award, bid tabulation, publication by posting electronically or by other means of a procedure, specification, term or condition which the person intends to protest, or the right to protest such matter shall be waived. The protest procedures may be obtained from the Purchasing Department and are included in the County's Purchasing Manual. All of the terms and conditions of the County Purchasing Manual are incorporated by reference and are fully binding.

St. Johns County reserves the right to accept or reject any or all bids/proposals, waive minor formalities, and to award the bid/proposal that best serves the interests of St. Johns County. St. Johns County also reserves the right to award the base bid and any alternate bids in any combination that best suits the needs of the County.

BOARD OF COUNTY COMMISSIONERS
OF ST. JOHNS COUNTY, FLORIDA
CHERYL STRICKLAND, CLERK

BY: _____
Deputy Clerk



St. Johns County Board of County Commissioners

Purchasing Division

August 14, 2014

ADDENDUM #1

To: Prospective Bidders
From: St. Johns County Purchasing Department
Subject: Bid No.: 14-105 - - Marsh Landing WWTP Influent Pump Station and Static Screens Improvements

This Addendum #1 is issued for further bidder's information and is hereby incorporated into the bid documents. Each bidder will ascertain before submitting a proposal that he/she has received all Addenda. *A fully executed acknowledgement of this addendum must be submitted with the Bid Proposal.*

Change/Clarifications:

Drawings:

1. ADD SHEET CD-2 to the Drawings.

THE BID DUE DATE IS: Wednesday, September 10, 2014 at 2:00 P.M.

Acknowledgment

Sincerely,

Signature and Date

Sharon L. Haluska
Contracts Manager
Purchasing Department

Printed Name and Title

Company Name (Print)

Attachments:

1. Sheet CD-2

END OF ADDENDUM #1



St. Johns County Board of County Commissioners

Purchasing Division

August 28, 2014

ADDENDUM #2

To: Prospective Bidders
From: St. Johns County Purchasing Department
Subject: Bid No.: 14-105 - - Marsh Landing WWTP Influent Pump Station and Static Screens Improvements

This Addendum #2 is issued for further bidder's information and is hereby incorporated into the bid documents. Each bidder will ascertain before submitting a proposal that he/she has received all Addenda. *A fully executed acknowledgement of this addendum must be submitted with the Bid Proposal.*

Changes/Clarifications:

DRAWINGS:

SHEET S-3

1. ROTATE North arrow on all Plans and Sections 90 degrees counterclockwise.

SHEET M-2

1. REVISE Item No. 7 on the Mechanical Equipment Schedule to read "CAST IRON PUMP BASE".

SHEET E-2:

1. REPLACE SHEET E-2 in the Drawings with attached SHEET E-2. The attached replacement drawing has been revised to change the quantity of Type Ex Terminal Boxes from two to three, Note 1 has been revised to include StaCon as an approved pump control panel manufacturer, Note 4 has been added to indicate that the Type Ex Terminal Boxes shall be furnished by the pump control panel manufacturer, and Single Line Diagram has been revised to delete the generator receptacle and circuit breaker.
2. REPLACE SHEET E-3 in the Drawings with attached SHEET E-3. The attached replacement drawing E-3 has been revised to incorporate pump motor overtemp relays.
3. REPLACE SHEET E-5 in the Drawings with attached SHEET E-5. The attached replacement drawing has been revised to change the quantity of Type Ex Terminal Boxes from two to three.
4. REPLACE SHEET E-6 in the Drawings with attached SHEET E-6. The attached replacement drawing has been revised to change the quantity of Type Ex Terminal Boxes from two to three.

SPECIFICATIONS:

SECTION 02622 POLYVINYL CHLORIDE (PVC) YARD PIPING

1. Section 02622, Paragraph 1.04 B – ADD “3. AWWA C153 - Ductile- Iron Compact Fittings, 3-in through 24-in and 54-in through 64-in.” and renumber remaining Items in Paragraph 1.04 B.
2. Section 02622, Paragraph 2.01 D – ADD “or AWWA C153” after the words “AWWA C110”.

SECTION 11306 INFLUENT PUMP STATION SUBMERSIBLE PUMPS

1. Section 11306, Paragraph 2.03 C – REMOVE the words “mobile and stationary” and REPLACE with “rotating” and ADD the words “and stationary wear rings of nitrile coated steel” at the end of the first sentence.

SECTION 11331 STATIC SCREENS

1. Section 11331, Paragraph 1.06 B – ADD “Model GS-3048 as manufactured by PRO-Equipment, Inc. of Waukesha, WI, USA”.

SECTION 15072 DUCTILE IRON PIPE AND FITTINGS

1. Section 15072, Paragraph 1.06 C - ADD “7. AWWA C153 - Ductile- Iron Compact Fittings, 3-in through 24-in and 54-in through 64-in.” and renumber remaining Items in Paragraph 1.06 C.

SECTION 15100 VALVES AND APPURTENANCES

1. Section 15100, Paragraph 2.06 E – ADD “Golden Anderson” following the word “M&H”.

QUESTIONS AND GENERAL INFORMATION:

1. What is the project duration to Substantial and Final Completion?

Answer: Project duration is one-hundred and eighty (180) consecutive calendar days from Notice to Proceed to Substantial Completion, and thirty (30) consecutive calendar days from Substantial Completion to Final Completion.

2. What is the estimated budget for this project?

Answer: Estimated budget for this project is \$400,000.00.

3. Is electrical contractor or the pump supplier to provide the Rose Bopla demarcation boxes?

Answer: Type Ex Terminal Boxes shall be furnished by the pump control panel manufacturer. Please see updated Sheet E-2 attached to this Addendum.

4. I could not find a spec telling me if this project requires Domestic pipe & fittings, or can we quote import as long as they meet AWWA specifications

Answer: Fittings may be domestic or imported. The submitted manufacturer and fittings shall meet the specifications requirements.

5. Ductile iron pipe fitting spec calls for all fittings to be C110, does this apply to mechanical joint fittings, or can we quote compact C153 MJ 350 psi?

Answer: C153 Compact MJ fittings will be allowed for this project. Sections 02622 and 15072 have been updated.

6. SHEET # CD-1 details show tracer wire detail. What size tracer wire do we need to quote?

Answer: Locate wire shall be 10 gauge, single strand, UF rated (direct burial), copper wire with 30 mil (minimum) insulation per St. Johns County Utility Department Manual of Water, Wastewater, and Reuse Design Standards & Specifications, Section 3.8.1- B.

7. Sheet # C-2 shows 1-1/2" PW hooking up to the 10" sewer FM

Answer: Sheet C-2 shows the 1-1/2" PW connecting to the existing 1-1/2" PW. The note "Connect to Existing" has two arrows, one to the PW connection and one for the new 10-inch FM connection.

8. Is a MPE duplexer pump controller & level probe what is required?

Answer: The MPE duplexer pump controller and level probe are required for all pump manufacturers.

9. Attached are our [Flygt] pump selections for your review. I included (2) jockey pump selections in which our 5HP will meet the duty point but will overload down towards run out. The pump will still operate within the service factor rating of the pump so it should work fine for the application. Please let me know which of these pump selections meet your approval.

Answer: The Xylem Flygt NP 3102 3102 MT 3 ~ Adaptive 462 5 hp pump and NP 3127 MT 3 ~ Adaptive 438 10 hp pump selections will satisfy the operating points and will be acceptable for this application.

10. Request to add ProEquipment as a named supplier [for static screen] by addendum.

Answer: ProEquipment has been added as an approved Manufacturer in Section 11331.

11. Section 11306, Paragraph 1.08 – Are any spare parts required for this project such as spare impellers and wear rings?

Answer: No spare parts are required for the submersible pumps. However, per Section 11306, the pump manufacturer shall have an authorized warranty center within a 175-mile radius of the job site equipped with a stock of all necessary spare parts for each model of pump furnished under this contract.

12. Section 11306, Paragraph 2.03.C – Please confirm that a rotating stainless steel wear ring and a nitrile rubber stationary wear ring is acceptable.

Answer: Rotating stainless steel wear ring and nitrile rubber coated steel stationary wear ring are acceptable. Section 11306, Paragraph 2.03 C has been revised to provide clarification.

13. Section 15100, Paragraph 2.06 – Can GA be approved as an acceptable manufacturer for the check valves? Product data is attached for reference. Please note that the GA 340-S will use a stainless steel body seat with a rubber faced disc.

Answer: GA valves have been added to Section 15100 as an approved manufacturer for the check valves.

14. Sheet M-2, Pertaining to item 7 in the mechanical equipment schedule, note that the pump bases will be cast iron per spec 11306 paragraph 2.03.H, not ductile iron.

Answer: Noted. Item 7 on the Mechanical Equipment Schedule included on Sheet M-2 will be updated to read Cast Iron Pump Base.

15. Sheet E-2, Are alternate panel manufacturers acceptable provided they comply with the details of these documents as well as SJCUD standards?

Answer: Sheet E-2 has been updated to add StaCon as an additional approved panel manufacturer. There are no alternate acceptable panel manufacturers than those listed on Sheet E-2. Please see updated Sheet E-2 attached to this Addendum.

16. Sheet E-2, The drawing shows that a standby generator is installed on-site for the WWTP. Please confirm that an emergency generator receptacle is still required on the pump control panel.

Answer: The emergency generator receptacle is not required on the pump control panel. Single Line Diagram has been revised to delete the generator receptacle and circuit breaker. Please see updated Sheet E-2 attached to this addendum.

THE BID DUE DATE IS: Wednesday, September 10, 2014 at 2:00 P.M.

Acknowledgment

Sincerely,

Signature and Date

Sharon L. Haluska
Contracts Manager
Purchasing Department

Printed Name and Title

Company Name (Print)

Attachments:

1. SHEET E-2
2. SHEET E-3
3. SHEET E-5
4. SHEET E-6

END OF ADDENDUM #2

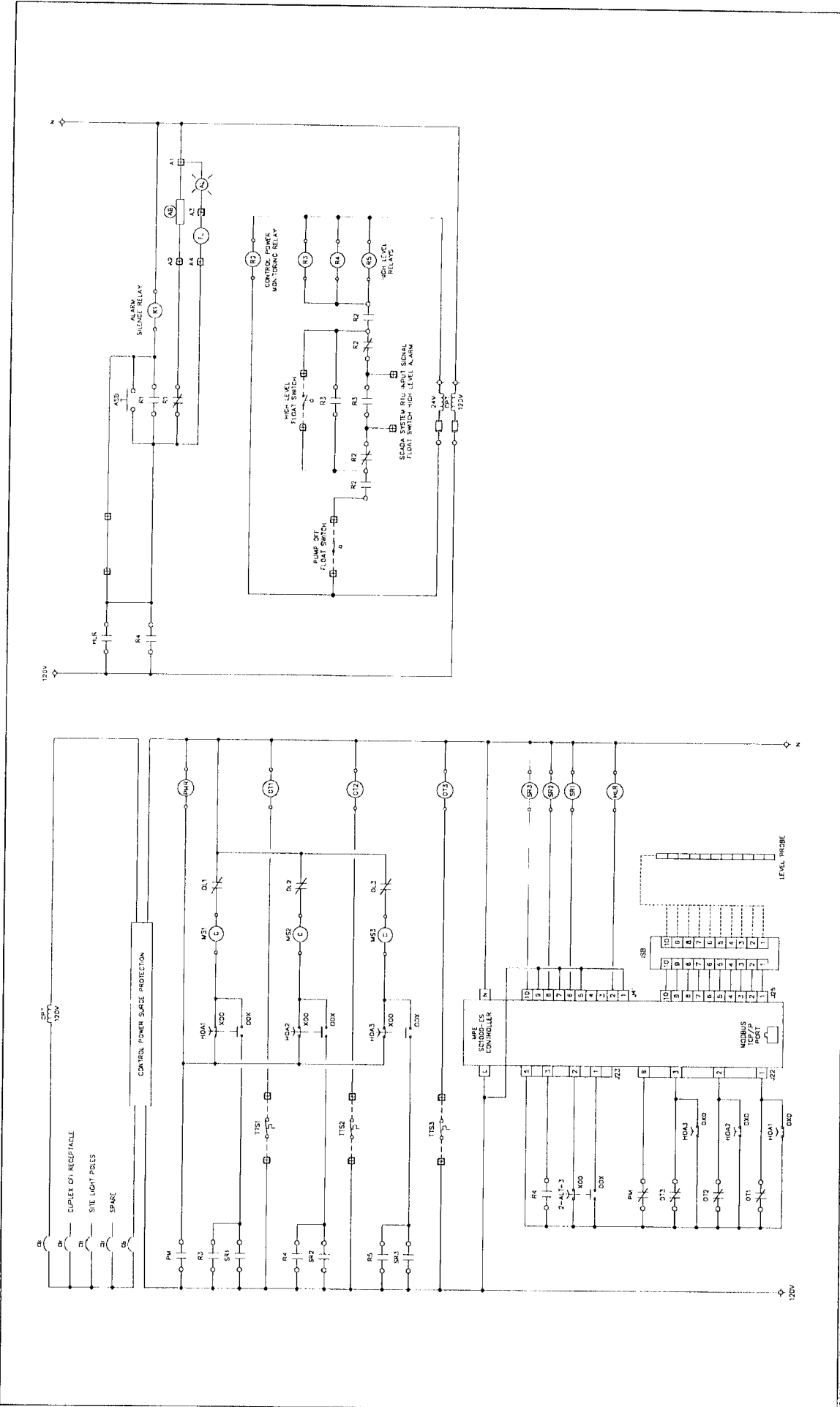

NO. BY	DATE	SYMBOL	REVISIONS	NO. SHEETS
1				1
2				2
3				3
4				4
5				5
6				6
7				7
8				8
9				9
10				10
11				11
12				12
13				13
14				14
15				15
16				16
17				17
18				18
19				19
20				20
21				21
22				22
23				23
24				24
25				25
26				26
27				27
28				28
29				29
30				30
31				31
32				32
33				33
34				34
35				35
36				36
37				37
38				38
39				39
40				40
41				41
42				42
43				43
44				44
45				45
46				46
47				47
48				48
49				49
50				50
51				51
52				52
53				53
54				54
55				55
56				56
57				57
58				58
59				59
60				60
61				61
62				62
63				63
64				64
65				65
66				66
67				67
68				68
69				69
70				70
71				71
72				72
73				73
74				74
75				75
76				76
77				77
78				78
79				79
80				80
81				81
82				82
83				83
84				84
85				85
86				86
87				87
88				88
89				89
90				90
91				91
92				92
93				93
94				94
95				95
96				96
97				97
98				98
99				99
100				100

ST. JOHNS COUNTY
 UTILITY DEPARTMENT
 1000 EAST ROAD 14
 PALM BEACH, FL 33411
 PHONE: (561) 844-2200 FAX: (561) 844-2202

MARSH LANDING WWTP
 INFLUENT PUMP STATION
 AND STATIC SCREENS
 IMPROVEMENTS

ISSUED FOR BID

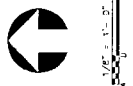

NOTES:

1. FOR PROPOSED WORK, VERIFY THE SITE WORK TO BE TO EVALUATE THE EXISTING CONDITIONS AND VERIFY THE FIELD COORDINATION WITH STATION OPERATIONS TO PREVENT ANY CHANGE OF OPERATION DURING CONSTRUCTION.
2. THE CONTRACTOR SHALL TAKE PRECAUTIONS TO AVOID THE EXISTING ELECTRICAL CONDUITS, BRICKWORK, TELEPHONE, ETC. AND EXCAVATION UTILITIES IS UNKNOWN AND SURVEY LOCATIONS SHALL BE SHOWN FOR THE EXISTING UNDERGROUND UTILITIES ARE SHOWN. FIELD ADJUSTMENTS OF THE NEW FACILITIES TO ACCOMMODATE THE EXISTING SITE CONDITIONS.
3. SITE LIGHT POLES (DIRECT EMBEDDED ROUND TAPERED BERGASS POLE, UNARMED BUT CAST ALUMINUM HOUSING, AERIAL REFRACTION, IS TYPE V REPLACEMENT TESTED, OUTLET AT 2'-0" ABOVE GRADE).
4. FLOW METERS, ENDRESS-HAUER PROMINE PROCESSING CLAMP-ON ULTRASONIC FLOW METER MODEL: DW1M1-B1A2220B44.

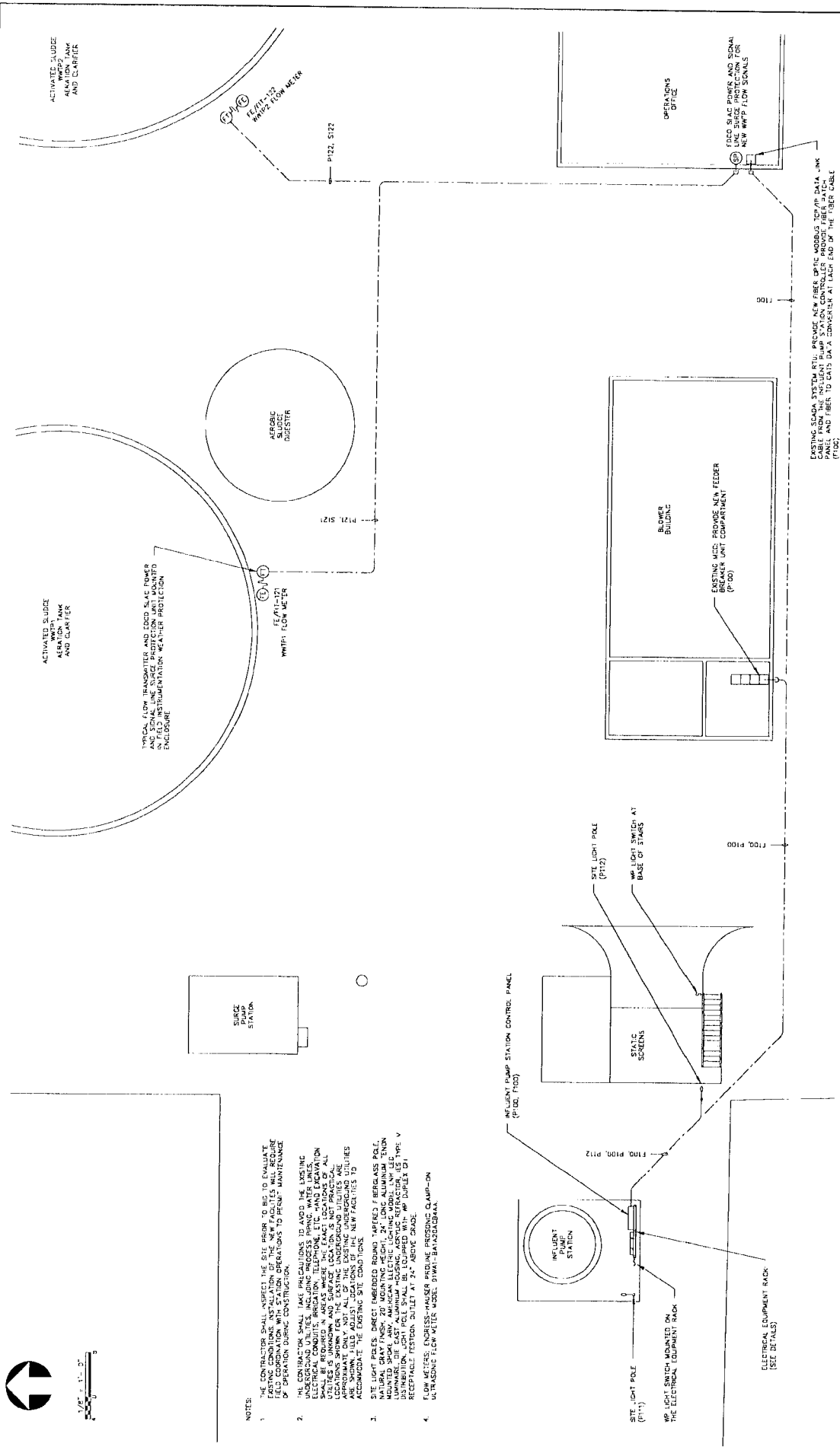

NO. SHEETS		ELECTRICAL SITE PLAN	
SHEET NO.		E-3	
DRAWING NO.		E-3	
ST. JOHNS COUNTY UTILITY DEPARTMENT <small>100 STATE ROAD 14</small> <small>PLANT CITY, FL 34686</small> <small>Phone (813) 947-1100 • Fax (813) 947-1102</small>			
MARSH LANDING WWTP INFLUENT PUMP STATION AND STATIC SCREENS IMPROVEMENTS		PROJECT ENGINEER SCOTT LAZZERINI, P.E. PLUMBING REGISTRATION NO. 39971	
NO.	DATE	BY	REVISION
1			
2			
3			
4			
5			
6			
7			
8			
9			
10			

ISSUED FOR BID

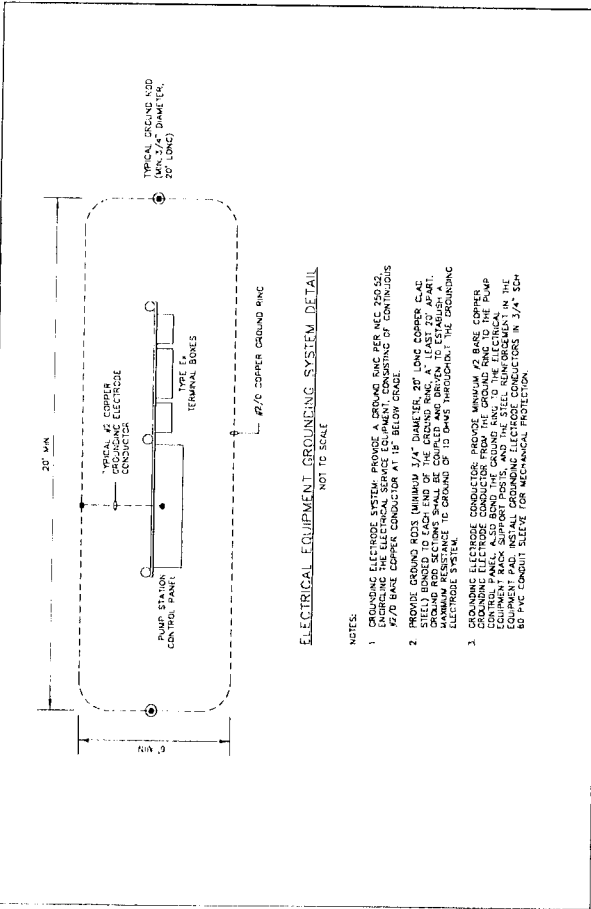

ELECTRICAL EQUIPMENT GROUNDING SYSTEM DETAIL
NOT TO SCALE

- NOTES:
1. GROUNDING ELECTRICAL SYSTEM PROVIDE A GROUND RING PER NEC 250.52, LOCATING THE RING AT THE CENTER OF THE EQUIPMENT, CONSISTING OF CONTINUOUS 1/2" BARE COPPER CONDUCTOR AT 18" BELOW GRADE.
 2. PROVIDE GROUND RODS (MINIMUM 1/2" DIAMETER, 20' LONG COPPER OR STEEL) BORED TO EACH END OF THE GROUND RING, AT LEAST 20' APART, MINIMUM RESISTANCE TO GROUND TO BE ESTABLISHED. THE GROUNDING ELECTRICAL SYSTEM.
 3. GROUNDING ELECTRICAL CONDUCTOR, PROVIDE MINIMUM #2 BARE COPPER CONDUCTOR FROM EACH CONDUIT TO THE GROUND RING TO THE PUMP EQUIPMENT RACK SUPPORT POSTS, AND THE STEEL RING OR GROUND IN THE EQUIPMENT RACK SUPPORT POSTS. PROVIDE MINIMUM #2 BARE COPPER OR 80 PVC CONDUIT SLEEVE FOR MECHANICAL PROTECTION.

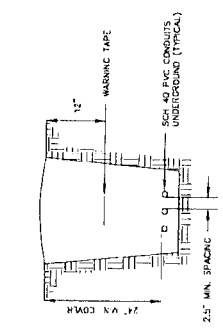

TYPICAL DIRECT BURIED CONDUIT DETAIL
NOT TO SCALE

- NOTES:
1. SEE ELECTRICAL SHEET FOR WIRE AND CABLE SCHEDULE FOR NUMBER AND SIZE OF CONDUITS.

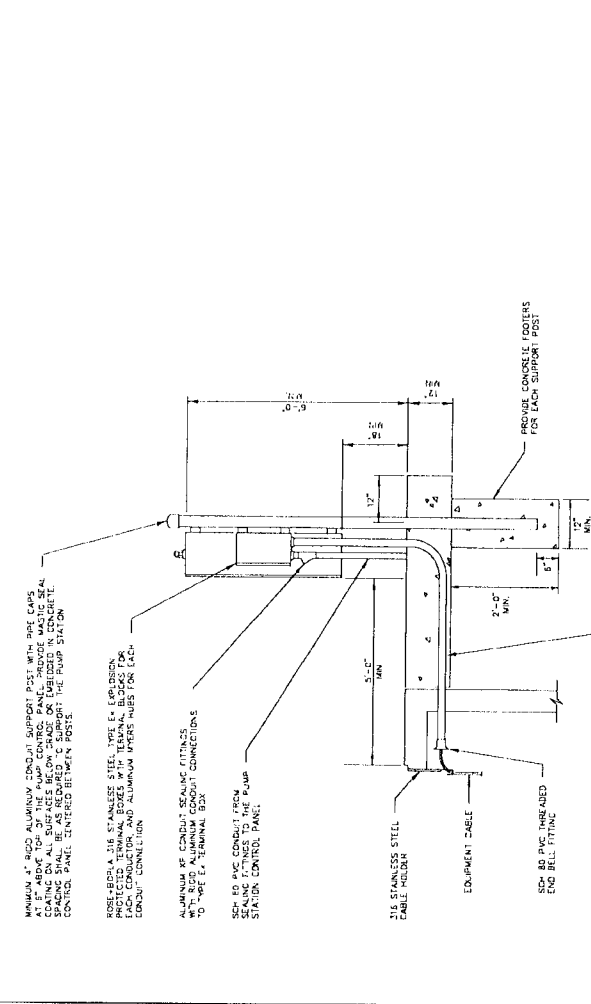

PUMP STATION ELECTRICAL EQUIPMENT INSTALLATION DETAIL
NOT TO SCALE

- MINIMUM 1/2" RIGID ALUMINUM CONDUIT SUPPORT POST WITH RPE CAPS COATING ON ALL SURFACES BELOW GRADE OR LAID IN CONCRETE CONDUIT PANEL. ENDS TO BE WELDED TO SUPPORT THE PUMP STATION CONTROL PANEL. ENDS TO BE WELDED TO SUPPORT THE PUMP STATION CONTROL PANEL.
- ROSE-BERLEA 21/8 STAINLESS STEEL TYPE E-1 EXPOSITION RESISTANT CABLE HOLDER WITH RIGID ALUMINUM CONDUIT CONNECTIONS TO TYPE E-1 TERMINAL BOX.
- SCH 80 PVC CONDUIT FROM THE PUMP STATION CONTROL PANEL.
- 21/8 STAINLESS STEEL CABLE HOLDER.
- EQUIPMENT CABLE.
- SCH 80 PVC INSULATED END BELL FITTING.
- PVC COATED RIGID ALUMINUM CONDUIT FROM E-1 TERMINAL BOXES TO MET WELL. SEE PER THE CABLE REQUIREMENTS. MINIMUM 1 1/2" FOR CONTROL CABLES.
- WARNING LIGHT.
- PUMP STATION CONTROL PANEL WITH NEMA 12/20 55 ENCLOSURE AND 20" X 40" FRONT INNER DOOR.
- SERVICE ENTRANCE CONDUIT AND GROUNDING SYSTEM CONDUITS SHALL BE SCH 80 PVC.
- TYPICAL CONDUITS FROM THE TYPE E-1 TERMINAL BOXES.
- TYPICAL EXPOSITION PROTECTED TYPE E-1 TERMINAL BOXES (MIN. 15.87", 11.5" W, 6.25" H) SHALL BE USED FOR ALL MOTOR FEEDS AND FOR PUMP MOTOR FEEDS (MIN. 15.87", 11.5" W, 6.25" H) FOR PUMP 2423 MOTOR FEEDS.
- STEEL RING OR GROUND IN THE EQUIPMENT RACK SUPPORT POSTS SHALL PROVIDE 2 LANKS OF 1/2" BARE COPPER OR 80 PVC CONDUIT SLEEVE FOR MECHANICAL PROTECTION.



ST. JOHNS COUNTY
UTILITY DEPARTMENT
1000 W. MARKET STREET, SUITE 100
DECATUR, GA 30030

MARSH LANDING WWTP
INFILTRATION PUMP STATION
AND STATION IMPROVEMENTS

DESIGN ENGINEER
ALVARO GARCIA, P.E.
FLORIDA REGISTRATION NO. 12474

DATE: 05/11/2011
DRAWN BY: J. H. HARRIS
CHECKED BY: J. H. HARRIS
SCALE: AS SHOWN

REVISIONS

NO.	DATE	SYMBOL	REVISIONS

ELECTRICAL DETAILS

NO. SHEETS
SHEET NO.
DRAWING NO.

SHEET FOR B/D



St. Johns County Board of County Commissioners

Purchasing Division

September 4, 2014

ADDENDUM #3

To: Prospective Bidders
From: St. Johns County Purchasing Department
Subject: Bid No.: 14-105 - - Marsh Landing WWTP Influent Pump Station and Static Screens Improvements

This Addendum #3 is issued for further bidder's information and is hereby incorporated into the bid documents. Each bidder will ascertain before submitting a proposal that he/she has received all Addenda. *A fully executed acknowledgement of this addendum must be submitted with the Bid Proposal.*

Changes/Clarifications:

DRAWINGS:

SHEET E-4:

1. SHEET E-4, Note 3 – DELETE “Modbus TCP/IP network communications” and REPLACE with “Modbus serial communications.” An existing spare CPU RS232 serial port shall be used for connection to the RTU. This change shall apply throughout the plans and specifications.
2. SHEET E-4, Note 4 – ADD “The pump control panel manufacturer shall furnish and install a fiber optic cable patch panel within the pump control panel (Corning WIC-012). The pump control panel manufacturer shall also include a duplex outlet within the control panel to be used for the fiber optic media converter power adapter.”

QUESTIONS AND GENERAL INFORMATION:

1. This item is a revision to Addendum No. 2, Questions and General Information Item No. 9. The Xylem Flygt NP 3102 3102 MT 3 ~ Adaptive 462 5 hp pump will not be acceptable for this application. Pump shall meet design requirements in Section 11306 without overloading.

THE BID DUE DATE IS: Wednesday, September 10, 2014 at 2:00 P.M.

Acknowledgment

Sincerely,

Signature and Date

Sharon L. Haluska
Contracts Manager
Purchasing Department

Printed Name and Title

Company Name (Print)

Attachments: None

END OF ADDENDUM #3

BID NO.: 14-105

OFFICIAL COUNTY BID FORM
ST. JOHNS COUNTY, FLORIDA
LUMP SUM BID PROPOSAL

PROJECT: MARSH LANDING WWTP INFLUENT PUMP STATION & STATIC SCREEN IMPROVEMENTS

TO: THE BOARD OF COUNTY COMMISSIONERS OF ST. JOHNS COUNTY, FLORIDA

DATE SUBMITTED: 09/10/14

BID PROPOSAL OF

Sawcross, Inc.

FULL LEGAL COMPANY NAME

10970 New Berlin Road, Jacksonville, FL 32226

(904) 751-7500

Address

Telephone No.

Having become familiar with site conditions of the project, and having carefully examined the Bidding requirements, including the Advertisement, Instructions to Bidders, and Contract Documents, including the General Conditions, Supplementary Conditions, Specifications, and Drawing entitled for construction of the Sunset Park Water Main Replacement in St. Johns County, Florida. The undersigned proposes to furnish all materials, labor and equipment, supervision and all other requirements necessary to comply with the Contract Documents for the following base bids quoted in this Bid Proposal summarized as follows:

BASE BID:

FOR: Construction of Marsh Landing WWTP Influent Pump Station & Static Screen Improvements project per plans and specifications.

\$ 603,000.00
Total Lump Sum Price (Numerical)

Six-hundred three-thousand & 00/100 /100 Dollars
(Amount written or typed in words)

Bidder will enter written (in words) and numerically by the Lump Sum Price in the space provided above. In the event of a conflict, the written Lump Sum Price shall be considered as the Bidder correct bid.

Time of Substantial Completion to be **one-hundred and eighty (180)** consecutive calendar days from receipt of Notice to Proceed from Owner.

Note: The listing order of bid items reflects a construction sequence in general terms for bidding purposes only and is not a specific construction schedule.

During the preparation of the Bid, the following addenda, if any, were received:

No.: 1 Date Received: 08/14/14

No.: 2 Date Received: 08/28/14

No.: 3 Date Received: 09/04/14

We, the undersigned, hereby declare that no person or persons, firm or corporation, other than the undersigned are interested, in this proposal, as principals, and that this proposal is made without collusion with any person, firm or corporation, and we have carefully and to our satisfaction examined the Project Specifications and form of Contract and Public Construction Bonds, together with the Plans.

We have made a full examination of the location of the proposed work and the sources of supply of materials, and we hereby agree to furnish all necessary labor, and equipment and materials, fully understanding that any quantities shown therewith are approximate only, and that we will fully complete all requirements therein as prepared by Architect, within the same time limit specified in the Contract Documents for the following total sum price as indicated above.

If the Undersigned is notified of the acceptance of this Bid Proposal by the Board within sixty (60) calendar days for the time set for the opening of Bids, the Undersigned further agrees, to execute a contract for the above work within ten (10) days after notice that his Bid has been accepted for the above stated compensation in the form of a Contract presented by the Owner.

The Undersigned agrees, if awarded the Contract, to Substantially Complete all work within **one-hundred and eighty (180)** consecutive calendar days and start work within ten (10) consecutive calendar days from receipt of NOTICE TO PROCEED. Undersigned further agrees that from the compensation otherwise to be paid, the Owner may retain the liquidated damages as provided in the Contract, which sum is agreed upon as the proper measure of liquidated damages which the Owner will sustain each day by the failure of the Undersigned to complete the work in the time stipulated, and this sum is not to be construed as penalty.

The Undersigned further agrees that security in the form of a Bid Bond, certified or cashier's check in the amount of not less than five percent (5%) total Bid Price, payable to the Owner, accompanies this Bid; that the amount is not to be construed as a penalty, but as liquidated damages which said Owner will sustain by failure of the Undersigned to execute and deliver the Contract and Bond within ten (10) days of the written notification of the Award of the Contract to him; thereupon, the security shall become the property of the Owner, but if this Bid is not accepted within sixty (60) days of the time set for the submission of Bids, or if the Undersigned delivers the executed Contract and Public Construction Bond upon receipt, the Security shall be returned to the Bidder within seven (7) working days.

CORPORATE/COMPANY

Full Legal Company Name: Sawcross, Inc. _____ (Seal)

By: Mark Hickinbotham, President _____
(Name & Title typed or printed)

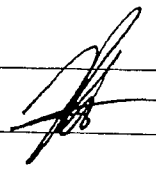

By: n/a _____
(Name & Title typed or printed)

Address: 10970 New Berlin Road, Jacksonville, FL 32226 _____

Telephone No.: (904) 751-7500 _____ Fax No.: (904) 751-0600 _____

Email Address for Authorized Company Representative: markh@sawcross.com _____

Federal I.D. Tax Number: 59-3136689 _____ DUNS #: 79-130-9834 _____

INDIVIDUAL

Name: n/a _____
(Signature) (Name typed or printed) (Title) n/a _____

Address: n/a _____

Telephone No.: () n/a _____ Fax No.: n/a _____

Email Address: n/a _____

Federal I.D. Tax Number: _____

- Bid Proposal Attachments:
- "A" - Affidavit
 - "B" - List of Proposed Subcontractors
 - "C" - Certificate as to Corporate Principal
 - "D" - Certificate of Compliance with Florida Trench Safety Act
 - "E" - License/Certification List
 - "F" - Certification of Previous Experience/Qualifications
 - Bid Bond
 - Fully Acknowledged Addenda Applicable to this bid

Attachments "A", "B", "C", "D", "E", "F" and Bid Bond must be completed and attached to Bidder's bid proposal along with a fully acknowledged copy of each Addendum applicable to this Bid.

Bid No.: 14-105

ATTACHMENT "A"

ST. JOHNS COUNTY, BOARD OF COUNTY COMMISSIONERS AFFIDAVIT

TO: ST. JOHNS COUNTY, BOARD OF COUNTY COMMISSIONERS, ST. JOHNS COUNTY, ST. AUGUSTINE, FLORIDA.

At the time the proposal is submitted, the Bidder shall attach to his Bid a sworn statement.

This sworn statement shall be an affidavit in the following form, executed by an officer of the firm, association, or corporation submitting the proposal, and shall be sworn to before a person who is authorized by law to administer oaths.

STATE OF FLORIDA, COUNTY OF ST. JOHNS

Before me, the Undersigned authority, personally appeared Mark Hickinbotham who being duly sworn, deposes and says he is President (Title) of the firm of Sawcross, Inc. Bidder submitting the attached proposal for the services covered by the bid documents for Bid # 14-105 for Marsh Landing WWTP Influent Pump Station & Static Screen Improvements, in St. Johns County, Florida.

The affiant further states that no more that one proposal for the above-referenced project will be submitted from the individual, his firm or corporation under the same or different name, and that such Bidder has no financial interest in the firm of another bidder for the same work. That he, his firm, association or corporation has neither directly, nor indirectly entered into any agreement, participated in any collusion, or otherwise taken any action in restraint of free competitive bidding in connection with this firm's Bid on the above-described project. Furthermore, neither the firm nor any of its officers are barred from participating in public contract lettings in the State of Florida or any other state.

Sawcross, Inc.
(Bidder)
By: [Signature]
President
(Title)

Sworn and subscribed to me this 10th day
of September, 20 14.

Notary Public:
[Signature]
Signature
Marie Baker
Printed



My commission Expires: 03/15/16

BIDDER ON ALL COUNTY PROJECTS MUST EXECUTE AND ATTACH THIS AFFADAVIT TO EACH BID.

Bid No.: 14-105

ATTACHMENT "C"

CERTIFICATES AS TO CORPORATE PRINCIPAL

I, Frances Hickinbotham, certify that I am the Secretary of the Corporation named as Principal in the attached bond; that Mark Hickinbotham who signed the said bond on behalf of the Principal, was then President of said Corporation; that I know his signature, and his signature hereto is genuine; and that said bond was duly signed, sealed, and attested for and in behalf of said Corporation by authority of it's governing body.

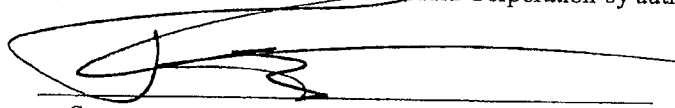
Secretary Corporate Seal

(STATE OF FLORIDA
COUNTY OF ST. JOHNS)

Before me, a Notary Public duly commissioned, qualified and acting, personally appeared Mark Hickinbotham to me well known, who being by me first duly sworn upon oath, says that he is the Attorney-In-Fact, for the Corporation and that he has been authorized by Sawcross, Inc. to execute the foregoing bond on behalf of the surety named therein in favor of St. Johns County, Florida.

Subscribed and sworn to me this 10th day of September, 20 14, A.D.

NOTARY PUBLIC
State of Florida-at-large

Marie Baker

My Commission Expires: 03/15/16



(Attach Power of Attorney to original Bid Bond and Financial Statement of Surety Company)

Bid No.: 14-105

ATTACHMENT "D"

Certificate of Compliance with the Florida Trench Safety Act

Bidder acknowledges that he is solely responsible for complying with the Florida Trench Safety Act (ACT) and Occupational Safety and Health Administrations excavation safety standard 29 CFR 1926.650 (Subpart P as amended) and the St. Johns County Trenching and Excavation Safety Program. If there is a conflict between the ACT and the St. Johns County Trenching and Excavation Safety Program, the more stringent requirement would apply. Bidder further acknowledges that included in the various items of the proposal and in the Total Bid Price are costs for complying with the Florida Trench Safety Act (90-96, Laws of Florida) effective October 1, 1990 and the Occupational Safety and Health Administrations excavation safety standard.

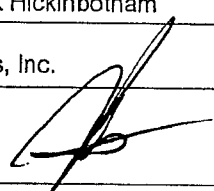
By: Mark Hickenbotham
Sawcross, Inc.
Bidder

Authorized Signature

09/10/14
Date

Bid No.: 14-105

ATTACHMENT "E"

License/Certification List

In the space below, the Bidder shall list all **current** licenses and certifications held.

The bidder shall attach a copy of each current license or certification listed below to this form.

License Name	License #	Issuing Agency	Expiration Date
Please see attached Licenses and Certifications.			



SAWCROSS INCORPORATED

10970 NEW BERLIN ROAD JACKSONVILLE, FL 32226-2270
904-751-7500 (VOICE) 904-751-0600 (FAX) WWW.SAWCROSS.COM (INTERNET)

BIDDER FLORIDA LICENSES SHEET

For use in bidding purposes only.

FLORIDA LICENSES			
State	License	Number	Expiration
Florida	CGC	036203	08/31/16
Florida	CMC	056728	08/31/16
Florida	CUC	056787	08/31/16
Florida	CFC	1427747	08/31/16
Florida	PCC	1256908	08/31/16
Florida	PE	0036099	02/28/15
Florida	Fire Protection System	189609-0001-2010	06/30/16



STATE OF FLORIDA
DEPARTMENT OF BUSINESS AND PROFESSIONAL REGULATION

CONSTRUCTION INDUSTRY LICENSING BOARD
1940 NORTH MONROE STREET
TALLAHASSEE FL 32399-0783

(850) 487-1395

HICKINBOTHAM, MARK EDWARD
SAWCROSS INC
8127 WEKIVA LANE
JACKSONVILLE FL 32256

Congratulations! With this license you become one of the nearly one million Floridians licensed by the Department of Business and Professional Regulation. Our professionals and businesses range from architects to yacht brokers, from boxers to barbeque restaurants, and they keep Florida's economy strong.

Every day we work to improve the way we do business in order to serve you better. For information about our services, please log onto www.myfloridalicense.com. There you can find more information about our divisions and the regulations that impact you, subscribe to department newsletters and learn more about the Department's initiatives.

Our mission at the Department is: License Efficiently, Regulate Fairly. We constantly strive to serve you better so that you can serve your customers. Thank you for doing business in Florida, and congratulations on your new license!

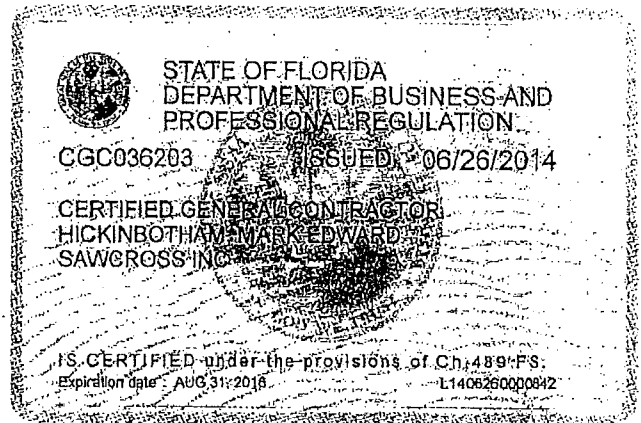

DETACH HERE

RICK SCOTT, GOVERNOR

KEN LAWSON, SECRETARY

STATE OF FLORIDA
DEPARTMENT OF BUSINESS AND PROFESSIONAL REGULATION
CONSTRUCTION INDUSTRY LICENSING BOARD



LICENSE NUMBER

CGC036203

The GENERAL CONTRACTOR
Named below IS CERTIFIED
Under the provisions of Chapter 489 FS
Expiration date: AUG 31, 2016

HICKINBOTHAM, MARK EDWARD
SAWCROSS INC
10970 NEW BERLIN ROAD
JACKSONVILLE FL 32226-2270



ISSUED: 06/26/2014

DISPLAY AS REQUIRED BY LAW

SEQ # L1406260000842



STATE OF FLORIDA
DEPARTMENT OF BUSINESS AND PROFESSIONAL REGULATION

CONSTRUCTION INDUSTRY LICENSING BOARD
1940 NORTH MONROE STREET
TALLAHASSEE FL 32399-0783

(850) 487-1395

HICKINBOTHAM, MARK EDWARD
SAWCROSS INC
8127 WEKIVA LANE
JACKSONVILLE FL 32256

Congratulations! With this license you become one of the nearly one million Floridians licensed by the Department of Business and Professional Regulation. Our professionals and businesses range from architects to yacht brokers, from boxers to barbeque restaurants, and they keep Florida's economy strong.

Every day we work to improve the way we do business in order to serve you better. For information about our services, please log onto www.myfloridallicense.com. There you can find more information about our divisions and the regulations that impact you, subscribe to department newsletters and learn more about the Department's initiatives.

Our mission at the Department is: License Efficiently, Regulate Fairly. We constantly strive to serve you better so that you can serve your customers. Thank you for doing business in Florida, and congratulations on your new license!

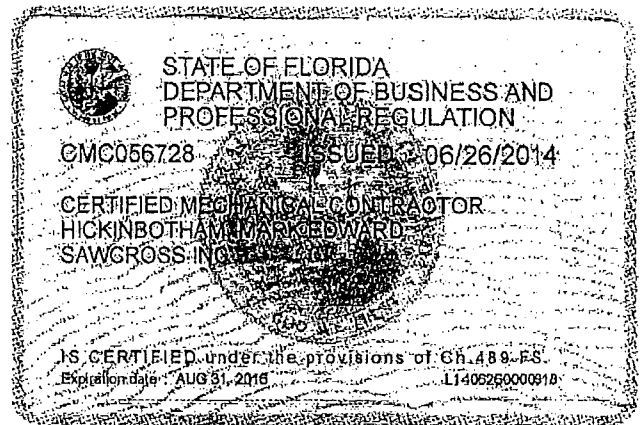

DETACH HERE

RICK SCOTT, GOVERNOR

KEN LAWSON, SECRETARY

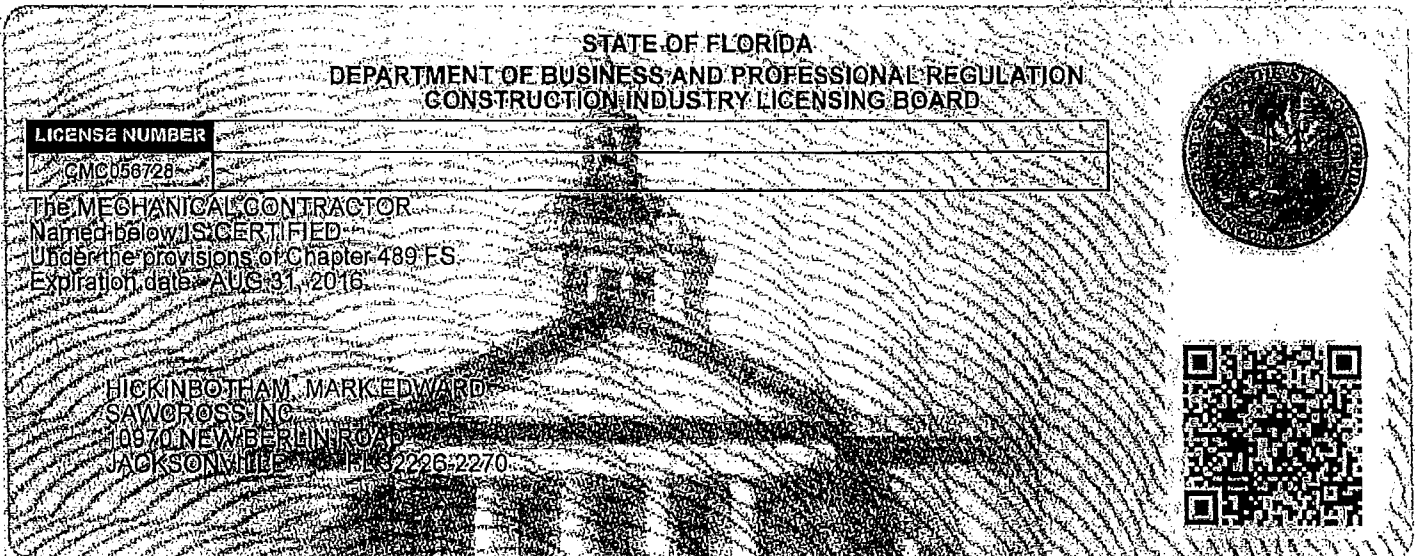

ISSUED: 06/26/2014

DISPLAY AS REQUIRED BY LAW

SEQ # L1406260000918



STATE OF FLORIDA
DEPARTMENT OF BUSINESS AND PROFESSIONAL REGULATION

CONSTRUCTION INDUSTRY LICENSING BOARD
1940 NORTH MONROE STREET
TALLAHASSEE FL 32399-0783

(850) 487-1395

HICKINBOTHAM, MARK EDWARD
SAWCROSS INC
8127 WEKIVA LANE
JACKSONVILLE FL 32256

Congratulations! With this license you become one of the nearly one million Floridians licensed by the Department of Business and Professional Regulation. Our professionals and businesses range from architects to yacht brokers, from boxers to barbeque restaurants, and they keep Florida's economy strong.

Every day we work to improve the way we do business in order to serve you better. For information about our services, please log onto www.myfloridalicense.com. There you can find more information about our divisions and the regulations that impact you, subscribe to department newsletters and learn more about the Department's initiatives.

Our mission at the Department is: License Efficiently, Regulate Fairly. We constantly strive to serve you better so that you can serve your customers. Thank you for doing business in Florida, and congratulations on your new license!

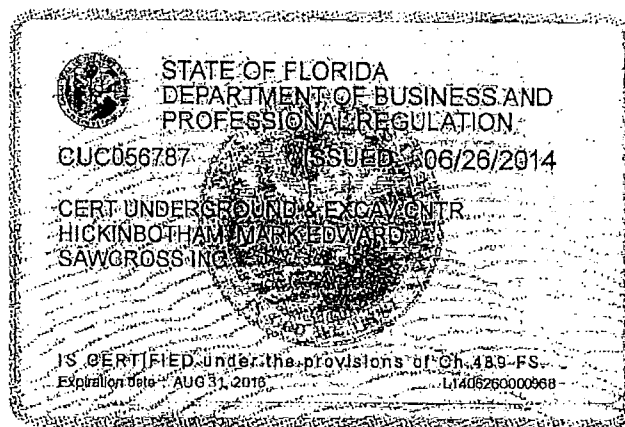

DETACH HERE

RICK SCOTT, GOVERNOR

KEN LAWSON, SECRETARY

STATE OF FLORIDA
DEPARTMENT OF BUSINESS AND PROFESSIONAL REGULATION
CONSTRUCTION INDUSTRY LICENSING BOARD

LICENSE NUMBER	CUC056787
----------------	-----------

The UNDERGROUND UTILITY & EXCAVATION CO. Named below IS CERTIFIED Under the provisions of Chapter 489 FS Expiration date: AUG 31, 2016

HICKINBOTHAM, MARK EDWARD
SAWCROSS INC
10970 NEWBERN ROAD
JACKSONVILLE FL 32226-2270

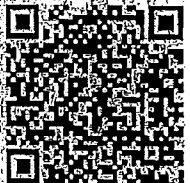
ISSUED: 06/26/2014

DISPLAY AS REQUIRED BY LAW

SEQ# L140626000968



STATE OF FLORIDA
DEPARTMENT OF BUSINESS AND PROFESSIONAL REGULATION

CONSTRUCTION INDUSTRY LICENSING BOARD
1940 NORTH MONROE STREET
TALLAHASSEE FL 32399-0783

(850) 487-1395

HICKINBOTHAM, MARK EDWARD
SAWCROSS INC
8127 WEKIVA LANE
JACKSONVILLE FL 32256

Congratulations! With this license you become one of the nearly one million Floridians licensed by the Department of Business and Professional Regulation. Our professionals and businesses range from architects to yacht brokers, from boxers to barbeque restaurants, and they keep Florida's economy strong.

Every day we work to improve the way we do business in order to serve you better. For information about our services, please log onto www.myfloridalicense.com. There you can find more information about our divisions and the regulations that impact you, subscribe to department newsletters and learn more about the Department's initiatives.

Our mission at the Department is: License Efficiently, Regulate Fairly. We constantly strive to serve you better so that you can serve your customers. Thank you for doing business in Florida, and congratulations on your new license!

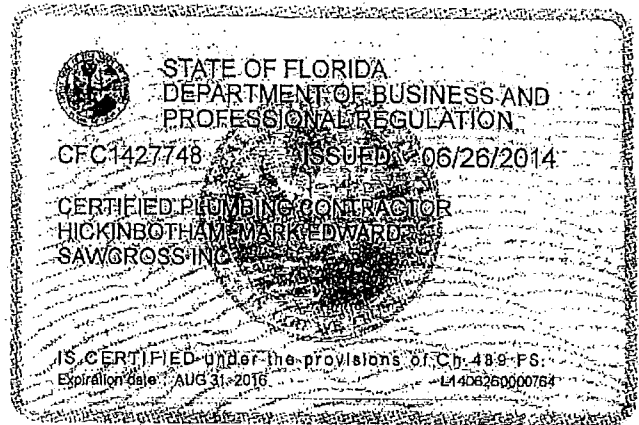

DETACH HERE

RICK SCOTT, GOVERNOR

KEN LAWSON, SECRETARY

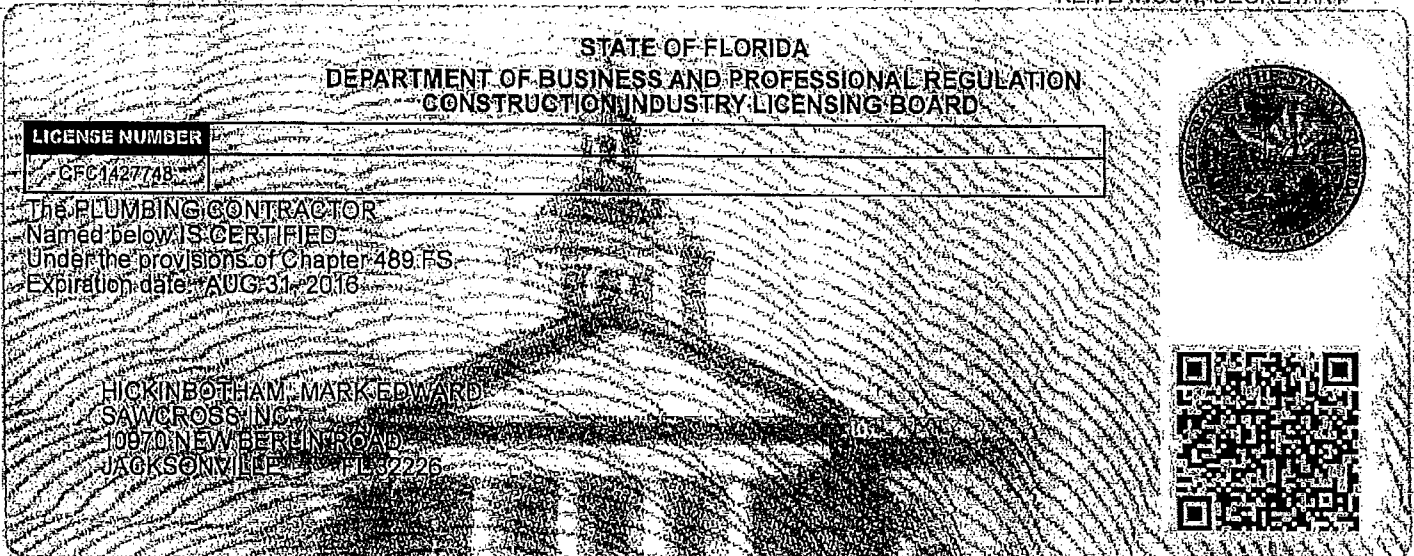

ISSUED: 06/26/2014

DISPLAY AS REQUIRED BY LAW

SEQ# L1406260000764



STATE OF FLORIDA
DEPARTMENT OF BUSINESS AND PROFESSIONAL REGULATION

CONSTRUCTION INDUSTRY LICENSING BOARD
1940 NORTH MONROE STREET
TALLAHASSEE FL 32399-0783

(850) 487-1395

HICKINBOTHAM, MARK EDWARD
SAWCROSS, INC
8127 WEKIVA LANE
JACKSONVILLE FL 32256

Congratulations! With this license you become one of the nearly one million Floridians licensed by the Department of Business and Professional Regulation. Our professionals and businesses range from architects to yacht brokers, from boxers to barbeque restaurants, and they keep Florida's economy strong.

Every day we work to improve the way we do business in order to serve you better. For information about our services, please log onto www.myfloridalicense.com. There you can find more information about our divisions and the regulations that impact you, subscribe to department newsletters, and learn more about the Department's initiatives.

Our mission at the Department is: License Efficiently, Regulate Fairly. We constantly strive to serve you better so that you can serve your customers. Thank you for doing business in Florida, and congratulations on your new license!



DETACH HERE

RICK SCOTT, GOVERNOR

KEN LAWSON, SECRETARY

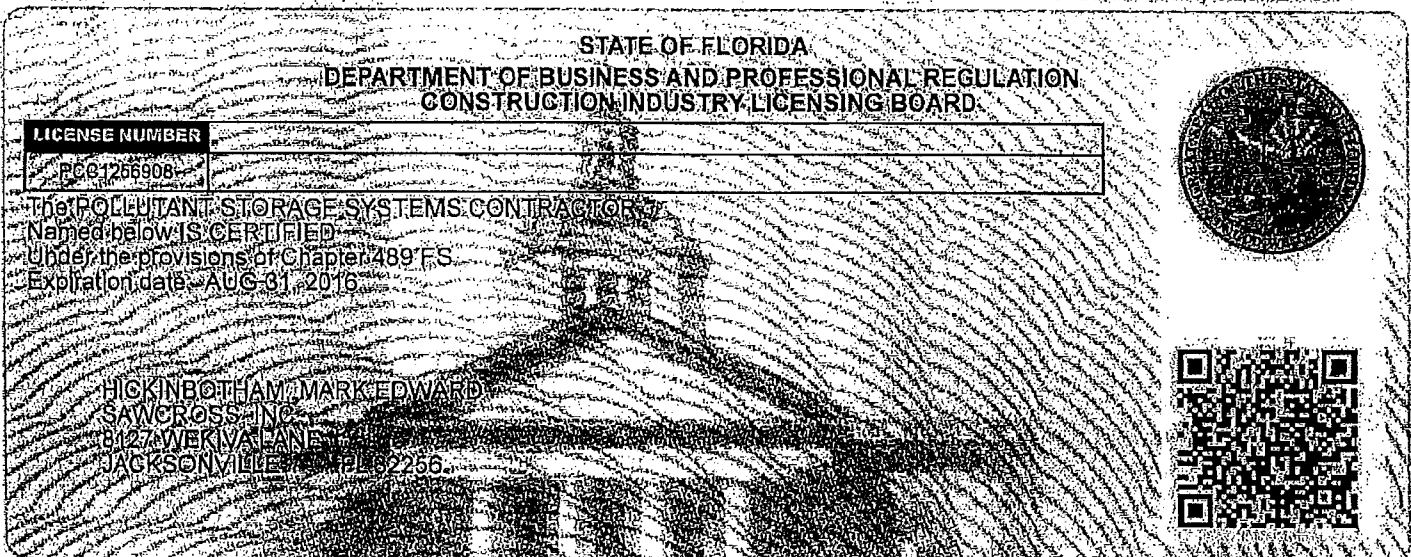

ISSUED: 06/26/2014

DISPLAY AS REQUIRED BY LAW

SEQ # L1406260000994

State of Florida

Board of Professional Engineers

Mark Edward Hickinbotham P.E.

Is licensed as a Professional Engineer under Chapter 471, Florida Statutes

Expiration: 2/26/2016

Arch. No. 228201507619

P.E. Lic. No.

228089

State of Florida



Department of State

I certify that the attached is a true and correct copy of the Articles of Incorporation of SAWCROSS, INC., a corporation organized under the Laws of the State of Florida, filed on July 31, 1992, as shown by the records of this office.

The document number of this corporation is V55559.

Given under my hand and the
Great Seal of the State of Florida,
at Tallahassee, the Capital, this the
7th day of August, 1992.



CR2EO22 (2-91)

A handwritten signature in cursive script that reads "Jim Smith".

Jim Smith
Secretary of State



2013-2014 BUSINESS TAX RECEIPT
 MICHAEL CORRIGAN, DUVAL COUNTY TAX COLLECTOR
 231 E. FORSYTH STREET, SUITE 130, JACKSONVILLE, FL 32202-3370
 Phone: (904) 630-1916, option 3; Fax: (904) 630-1432
 Website: www.coj.net/tc; Email: taxcollector@coj.net

Note – A penalty is imposed for failure to keep this receipt exhibited conspicuously at your place of business.
 This renewal application is furnished pursuant to Municipal Ordinance Code Chapters 770-772, for the period
 October 1, 2013 through September 30, 2014.

SAWCROSS INC
 MARK E HICKINBOTHAM
 10970 NEW BERLIN RD
 JACKSONVILLE, FL 32226-2270

ACCOUNT NUMBER:	770480000		
LOCATION ADDRESS:	10970 NEW BERLIN RD JACKSONVILLE, FL 32226-2270		
DESCRIPTION:	CONTRACTOR- ALL TYPES		
COUNTY RECEIPT DESC:	CONTRACTOR- ALL TYPES	COUNTY TAX:	22.50
MUNICIPAL RECEIPT DESC:	MC 772.809	MUNICIPAL TAX:	101.25
		TOTAL TAX PAID:	123.75

VALID UNTIL September 30, 2014

***** ATTENTION *****

**THIS RECEIPT IS FOR BUSINESS TAX RECEIPT ONLY.
 CERTAIN BUSINESSES MAY REQUIRE ADDITIONAL STATE LICENSING.**

This is a business tax receipt only. It does not permit the receipt holder to violate any existing regulatory or zoning laws of the County or City. It does not exempt the receipt holder from any other license or permit required by law. This is not a certification of the receipt holder's qualifications.

Michael Corrigan Jr.

TAX COLLECTOR

THIS BECOMES A RECEIPT AFTER VALIDATION.

PAID-3448236.0001-0001 M01 07/30/2013 123.75

Bid No. 14-105 – Marsh Landing WWTP Influent Pump Station & Static Screen Improvements

Company Name: Sawcross, Inc.

**ATTACHMENT "F"
Certification of Previous Experience & Qualifications**

1. Name of Project: Please see attached Project Reference Sheets.
Project Description: _____

Owner Name: _____
Contact Name, Title: _____
Phone # & Email Address: _____
Dollar Value of Project: _____
Completion Date of Project: _____

2. Name of Project: Please see attached Project Reference Sheets.
Project Description: _____

Owner Name: _____
Contact Name, Title: _____
Phone # & Email Address: _____
Dollar Value of Project: _____
Completion Date of Project: _____

3. Name of Project: Please see attached Project Reference Sheets.
Project Description: _____

Owner Name: _____
Contact Name, Title: _____
Phone # & Email Address: _____
Dollar Value of Project: _____
Completion Date of Project: _____

Bidder hereby certifies that the above named company has been in business for five (5) years, is licensed to work in the State of Florida, is a current Certified General or Underground Utility Contractor and has successfully construction the above projects.

By: Mark Hickinbotham, President
_____ Print Name & Title

09/10/14
_____ Date

_____ Authorized Signature

JEA ARLINGTON BOOSTER PUMP STATION

Jacksonville, Florida



Project consisted of the construction of a new 8 MGD potable water booster pumping station at the JEA Arlington Water Treatment Plant. The station was feed from a new 36" water line from a well field on the west side of the St. Johns River and boosted pressure and supply to the City's Southside grid. Work consisted of installing a new 36" ductile iron suction header and new 36" ductile iron discharge header. Installed three (3) owner furnished 250 H.P. horizontal split case booster pumps. Complete construction of a new 5000 s.f. pump building. Furnished and installed three (3) new variable frequency drives and one (1) master SCADA control panel complete with all field instrumentation. Furnished and installed one (1) new complete sodium hypochlorite feed system with two major injection points at the 36" suction header for mixing through pumps. Work included all site work, concrete driveway, plumbing, HVAC and landscaping. Project was completed 93 days ahead of schedule and under budget by \$49,035.00. This was a very critical project with an extremely high degree of pressure to be completed on time.

OWNER

Jacksonville Electric Authority
21 West Church Street
Jacksonville, FL 32202
Mr. Steve Wiggins
(904) 665-6314
wiggsc@jea.com

ENGINEER

CDM-Smith
8381 Dix Ellis Trail, Suite 400
Jacksonville, FL 32256
Ms. Teri Pinson, P.E.
tpinson@co.st-johns.fl.us

Project Type

Master Water Booster
Pumping Station

Original Contract Amount

\$1,765,000.00

Final Contract Amount

\$1,712,795.00

Final Completion Date

September 2013

Original Contract Time

365 days

Final Contract Time

272 days



SAWCROSS, INC.

Contractors & Engineers
CGC036203 / EB8465

10970 New Berlin Road
Jacksonville, FL 32226

Office: (904) 751-7500
Fax: (904) 751-0600

www.sawcross.com

GRU MURPHREE WTP WELL #16

Gainesville, Florida

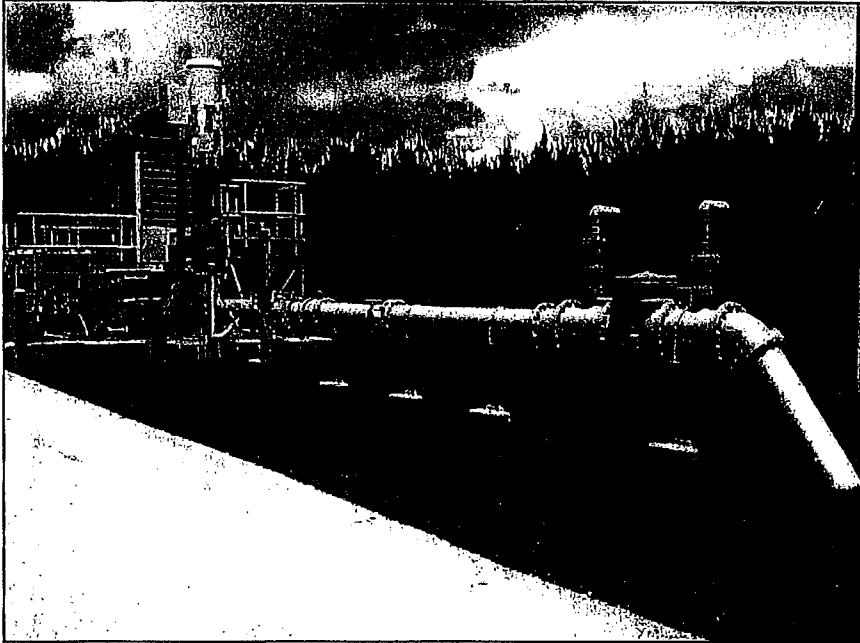

Project consisted of improving the existing well facility by removing the existing diesel driven vertical turbine raw water well pump. Performed a plumbness and alignment test to determine if the pump column length could be extended into the bore hole. The replacement equipment included a new Layne / Verti-Line 19 GH – six stage vertical turbine pump assembly capable of pumping 6.5 MGD at 253 feet of head, an Amarillo Combination Gear Drive and a Caterpillar Tier Four Diesel Motor. Additional improvements include a new concrete electrical building, electrical motor control center and RTU Communications to the Murphree WTP SCADA System. Extended contract time was solely due to incorrect manufacturing of the sole sourced Layne pump and US Motors motor. The pump column pipe and couplings could not be assembled in the field as a result of incorrect manufacturing and had to be completely remanufactured by Layne and the motor was shipped with the incorrect machining for the stub shaft and had to be remanufactured by US Motors.

OWNER

Gainesville Regional Utilities
301 S.E. 4th Avenue
Gainesville, FL 32601
Ms. Debbie Daugherty
(352) 393-1622
daughertydd@gru.com

ENGINEER

CH2M Hill
3011 SW Williston Road
Gainesville, FL 32608
Tim Ptak, P.E.
(352) 355-7991
tim.ptak@ch2m.com

Project Type

Bid/Build

Original Contract Amount

\$1,209,000.00

Final Contract Amount

\$1,209,000.00

Final Completion Date

May 2013

Original Contract Time

435 days

Final Contract Time

600 days



SAWCROSS, INC.

Contractors & Engineers

CGC036203 / EB8465

10970 New Berlin Road
Jacksonville, FL 32226

Office: (904) 751-7500

Fax: (904) 751-0600

www.sawcross.com

STARKE WASTEWATER TREATMENT PLANT UPGRADES

Starke, Florida



This project was for the complete upgrade of the 5 MGD WWTP for the City of Starke and consisted of complete rehabilitation of the existing aeration basins with new air diffusers, new stainless steel and ductile iron air piping, addition of new Vaughn chopper pumps with mixers for upgrade to biological nutrient removal, two new Aqua Aerobic tertiary filters, new aeration basin process slide gates, new concrete effluent pump station with two new vertical turbine effluent pumps, variable frequency drives for the effluent pumps, extensive yard piping modifications including several critical tie-ins, new plant reuse piping, all new electrical and instrumentation and all sitework including finish grading and grassing.

OWNER

City Commission,
City of Starke, Florida
209 North Thompson Street
Starke, FL 32091
Mr. Kyle Jerrels
(904) 964-7999
wwtp@cityofstarke.org

ENGINEER

Stone Engineering Group, Inc.
7400 Baymeadows Way
Suite 220
Jacksonville, FL 32256
Mr. Gary Sneddon, P.E.
(904) 448-5300
gsneddon@stonejoca.com

Project Type

Bid/Build

Original Contract Amount

\$2,011,000.00

Final Contract Amount

\$2,034,873.00

Final Completion Date

February 2009

Original Contract Time

270 days

Final Contract Time

308 days



SAWCROSS, INC.

Contractors & Engineers
CGC036203 / EB8465

10970 New Berlin Road
Jacksonville, FL 32226

Office: (904) 751-7500
Fax: (904) 751-0600

www.sawcross.com

BID NO.: 14-105

BID BOND

STATE OF FLORIDA
COUNTY OF ST. JOHNS

KNOW ALL MEN BY THESE PRESENTS, that Sawcross, Inc. as Principal, and Western Surety Company as Surety, are held and firmly bound unto St. Johns County, Florida, in the penal sum of 5% of Bid Amount Dollars (\$ 5.0%) lawful money of the United States, we bind ourselves, our heirs, executors, administrators, and successors, jointly and severally, firmly by these presents.

THE CONDITION OF THIS OBLIGATIONS IS SUCH, that whereas the Principal has submitted the accompanying Bid, dated September 10, 2014.

For
Marsh Landing WWTP Influent Pump Station & Static Screen Improvements

St. Johns County, Florida

NOW THEREFORE,

- (a) If the Principal shall not withdraw said Bid within sixty (60) days after Bid Award date, and shall within ten (10) days after prescribed forms are presented to him for signature, enter into a written Contract with the County in accordance with the Bid as accepted, and give Bond with good and sufficient Surety or Sureties, as may be required, for the faithful performance and proper fulfillment of such Contract, then the above obligations shall be void and of no effect, otherwise to remain in full force and virtue.
- (b) In the event of the withdrawal of said Bid within the period specified, or the failure to enter into such Contract and give such Bond within the time specified, if the Principal shall pay the County the difference between the amount specified, in said Bid and the amount for which the County may procure the required Work and supplies, if the latter amount be in excess of the former, then the above obligations shall be void and of no effect, otherwise to remain in full force and virtue.

IN WITNESS WHEREOF, the above bounded parties have executed this instrument under their several seals, this 9th day of September A.D., 20 14, the name and corporate seal of each corporate party being hereto affixed and these presents duly signed by its undersigned representative, pursuant to authority of it's governing body.

BID NO.: 14-98

WITNESSES:

(If Sole Ownership or Partnership two (2) Witnesses required).
(If Corporation, Secretary only will attest and affix seal).

WITNESSES:

Marie Baber

PRINCIPAL:

Sawcross, Inc.
NAME OF FIRM:

[Signature]
SIGNATURE OF AUTHORIZED OFFICER (AFFIX SEAL)

Mark Hickinbotham, President
TITLE

10970 New Berlin Road
BUSINESS ADDRESS

Jacksonville FL
CITY STATE

WITNESS:

[Signature]
Bobay Bryant

SURETY:

Western Surety Company
CORPORATE SURETY

Michelle B. O'Steen
ATTORNEY-IN-FACT (AFFIX SEAL)
Michelle B. O'Steen

333 S Wabash Ave., 41st Floor
BUSINESS ADDRESS

Chicago IL
CITY STATE

USI Insurance Services LLC
NAME OF LOCAL INSURANCE AGENCY

END OF SECTION

Western Surety Company

POWER OF ATTORNEY APPOINTING INDIVIDUAL ATTORNEY-IN-FACT

Know All Men By These Presents, That WESTERN SURETY COMPANY, a South Dakota corporation, is a duly organized and existing corporation having its principal office in the City of Sioux Falls, and State of South Dakota, and that it does by virtue of the signature and seal herein affixed hereby make, constitute and appoint

David L Cain, Juanita W Bowditch, Raynor E Bowditch, James J Pedoulas, Michelle B O'Steen, Individually

of Jacksonville, FL, its true and lawful Attorney(s)-in-Fact with full power and authority hereby conferred to sign, seal and execute for and on its behalf bonds, undertakings and other obligatory instruments of similar nature

- In Unlimited Amounts -

and to bind it thereby as fully and to the same extent as if such instruments were signed by a duly authorized officer of the corporation and all the acts of said Attorney, pursuant to the authority hereby given, are hereby ratified and confirmed.

This Power of Attorney is made and executed pursuant to and by authority of the By-Law printed on the reverse hereof, duly adopted, as indicated, by the shareholders of the corporation.

In Witness Whereof, WESTERN SURETY COMPANY has caused these presents to be signed by its Vice President and its corporate seal to be hereto affixed on this 19th day of April, 2013.

WESTERN SURETY COMPANY



Paul T. Bruflat
Paul T. Bruflat, Vice President

State of South Dakota }
County of Minnehaha } ss

On this 19th day of April, 2013, before me personally came Paul T. Bruflat, to me known, who, being by me duly sworn, did depose and say: that he resides in the City of Sioux Falls, State of South Dakota; that he is the Vice President of WESTERN SURETY COMPANY described in and which executed the above instrument; that he knows the seal of said corporation; that the seal affixed to the said instrument is such corporate seal; that it was so affixed pursuant to authority given by the Board of Directors of said corporation and that he signed his name thereto pursuant to like authority, and acknowledges same to be the act and deed of said corporation.

My commission expires
June 23, 2015

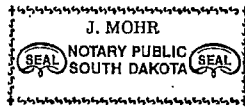

J. Mohr
J. Mohr, Notary Public

CERTIFICATE

I, L. Nelson, Assistant Secretary of WESTERN SURETY COMPANY do hereby certify that the Power of Attorney hereinabove set forth is still in force, and further certify that the By-Law of the corporation printed on the reverse hereof is still in force. In testimony whereof I have hereunto subscribed my name and affixed the seal of the said corporation this 9th day of September, 2014.



WESTERN SURETY COMPANY

L. Nelson
L. Nelson, Assistant Secretary



St. Johns County Board of County Commissioners

Purchasing Division

August 14, 2014

ADDENDUM #1

To: Prospective Bidders.
From: St. Johns County Purchasing Department
Subject: Bid No.: 14-105 - - Marsh Landing WWTP Influent Pump Station and Static Screens Improvements

This Addendum #1 is issued for further bidder's information and is hereby incorporated into the bid documents. Each bidder will ascertain before submitting a proposal that he/she has received all Addenda. *A fully executed acknowledgement of this addendum must be submitted with the Bid Proposal.*

Change/Clarifications:

Drawings:

1. ADD SHEET CD-2 to the Drawings.

THE BID DUE DATE IS: Wednesday, September 10, 2014 at 2:00 P.M.

Acknowledgment

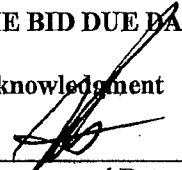

Signature and Date

09/10/14

Mark Hickinbotham, President
Printed Name and Title

Sawcross, Inc.
Company Name (Print)

Sincerely,

Sharon L. Haluska
Contracts Manager
Purchasing Department

Attachments:

1. Sheet CD-2

END OF ADDENDUM #1

16. Sheet E-2, The drawing shows that a standby generator is installed on-site for the WWTP. Please confirm that an emergency generator receptacle is still required on the pump control panel.

Answer: The emergency generator receptacle is not required on the pump control panel. Single Line Diagram has been revised to delete the generator receptacle and circuit breaker. Please see updated Sheet E-2 attached to this addendum.

THE BID DUE DATE IS: Wednesday, September 10, 2014 at 2:00 P.M.

Acknowledgment



Signature and Date

09/10/14

Mark Hickinbotham, President
Printed Name and Title

Sawcross, Inc.
Company Name (Print)

Sincerely,

Sharon L. Haluska
Contracts Manager
Purchasing Department

Attachments:

1. SHEET E-2
2. SHEET E-3
3. SHEET E-5
4. SHEET E-6

END OF ADDENDUM #2

THE BID DUE DATE IS: Wednesday, September 10, 2014 at 2:00 P.M.

Acknowledgment

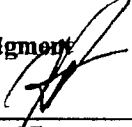

09/10/14
Signature and Date

Mark Hickinbotham, President
Printed Name and Title

Sawcross, Inc.
Company Name (Print)

Attachments: None

Sincerely,

Sharon L. Haluska
Contracts Manager
Purchasing Department

END OF ADDENDUM #3



**OFFICIAL COUNTY BID FORM
WITH ATTACHMENTS**

DRAFT

**STANDARD AGREEMENT
BETWEEN
OWNER AND CONTRACTOR**
(1992 EDITION, REVISED 12/18/13)

This Agreement is made _____, 20__ by and between St. Johns County, 500 San Sebastian View, St. Augustine, Florida 32084 (hereafter referred to as the "Owner") and Sawcross, Inc., 10970 New Berlin Road, Jacksonville, FL 32226 (p) (904) 751-7500 (f) (904) 751-0600 hereinafter referred to as the "Contractor") under seal for Construction of Bid No. 14-105 Marsh Landing WWTP Influent Pump Station and Static Screen Improvements referred to as the "Project"), the Owner and the Contractor hereby agreeing as follows:

**ARTICLE I
THE CONTRACT AND THE CONTRACT DOCUMENTS**

1.1 The Contract

1.1.1 The Contract between the Owner and the Contractor, of which this Agreement is a part, consists of the Contract Documents. It shall be effective on the date this Agreement is executed by the last party to execute it.

1.2 The Contract Documents

1.2.1 The Contract Documents consist of this Agreement, the Bid Documents and Bid Forms, Specifications, all Change Orders and Field Orders issued hereafter and executed by the parties and the Engineers, any other amendments hereto executed by the parties hereafter, together with the following (if any): Bid Documents, Addendum 1, 2 and 3 Bonds & Insurance

Documents not enumerated in this Paragraph 1.2.1 are not Contract Documents and do not form part of this Agreement.

1.3 Entire Agreement

1.3.1 The Contract, together with the Contractor's Public Construction Bond (if applicable) for the Project, constitutes the entire and exclusive agreement between the Owner and the Contractor with reference to the Project. Specifically, but without limitation, this Agreement supersedes any Bid Documents not listed among the Contract Documents described above and all prior written or oral communications, representations and negotiations, if any, between the Owner and Contractor.

1.4 No Privity with Others

1.4.1 Nothing contained in this Agreement shall create, or be interpreted to create, privity or any other contractual agreement between the Owner and any person or entity other than the Contractor.

1.5 Intent and Interpretation

1.5.1 The intent of this Agreement is to require complete, correct and timely execution of the Work. Any work that may be required implied or inferred by the Contract Documents, or any one or more of them, as necessary to produce the intended result shall be provided by the Contractor

for the Contract Price.

1.5.2 The Contract is intended to be an integral whole and shall be interpreted as internally consistent. What is required by any one Contract Document shall be considered as required by the Contract.

1.5.3 When a word, term or phrase is used in this Agreement, it shall be interpreted or construed, first, as defined herein; second, if not defined, according to its generally accepted meaning in the construction industry; and third, if there is no generally accepted meaning in the construction industry, according to its common and customary usage.

1.5.4 The words "include," "includes" or "including," as used in this Agreement, shall be deemed to be followed by the phrase "without limitation."

1.5.5 The specification herein of any act, failure, refusal, omission, event, occurrence, or condition as constituting a material breach of this Agreement shall not imply that any other, non-specified act, failure, refusal, omission, event, occurrence, or condition shall be deemed not to constitute a material breach of this Agreement.

1.5.6 Words or terms used as nouns in this Agreement shall be inclusive of their singular and plural forms, unless the context of their usage clearly requires a contrary meaning.

1.5.7 The Contractor shall have a continuing duty to read, carefully study and compare each of the Contract Documents, the Shop Drawings and the Product Data and shall give written notice to the Engineer and the Owner of any inconsistency, ambiguity, error or omission which the Contractor may discover with respect to these documents before proceeding with the affected Work. The issuance, or the express or implied approval by the Owner or the Engineer of the Contract Documents, Shop Drawings, or Product Data shall not relieve any such approval by evidence of the Contractor's compliance shall any such approval be evidence of the Contractor's compliance with the Contract. The Owner has requested the Engineer to only prepare documents for the Project, including the Drawings and Specifications for the Project, which are accurate, adequate, consistent, coordinated, and sufficient for construction. HOWEVER, THE OWNER MAKES NO REPRESENTATION OR WARRANTY OF ANY NATURE WHATSOEVER TO THE CONTRACTOR CONCERNING SUCH DOCUMENTS. By the execution hereof, the Contractor acknowledges and represents that it has received, reviewed and carefully examined such documents, has found them to be complete, accurate, adequate, consistent, coordinated and sufficient for construction, and that the Contractor has not, does not, and shall not rely upon any representation or warranties by the Owner concerning such documents as no such representation or warranties have been or are hereby made.

1.5.8 As between numbers and scaled measurements on the Drawings and in the Design, the numbers shall govern; as between larger scale and smaller scale drawings, the larger scale shall govern.

1.5.9 Neither the organization of any of the Contract Documents into divisions, sections, paragraphs, articles, (or other categories), nor the organization or arrangement of the Design, shall control the Contractor in dividing the Work or in establishing the extent or Scope of Work to be performed by Subcontractors.

1.6 Ownership of Contract Documents

1.6.1 The Contract Documents, and each of them, shall remain the property of the Owner. The Contractor shall have the right to keep one record set of the Contract Documents upon completion of the Project; provided, however, that in no event shall Contractor use, or permit to be used, any or all of such Contract Documents on other projects without Owner's prior written

authorization.

ARTICLE II THE WORK

2.1 The Contractor shall perform all of the Work required, implied, or reasonably inferable from, this Agreement.

2.2 The term "Work" shall mean whatever is done by or required of the Contractor to perform and complete its duties under this Agreement, including the following: construction of the whole or a designated part of the Project in the manner set forth in the Contract Documents; furnishing of any required Surety Bonds and insurance; and the provision or furnishing of labor, supervision, services, materials, supplies, equipment, fixtures, appliances, facilities, tools, transportation, storage, power, permits and licenses required of the Contractor, fuel, heat, light, cooling and all other utilities as required by this Agreement. The Work to be performed by the Contractor is generally described as follows:

The scope of work for this project shall include furnishing all labor, materials, equipment and any other items necessary for demolition of an existing lined influent wastewater surge pond and existing influent static screen slab on grade, construction of a new elevated influent wastewater static screen and base structure, relocation of an existing static screen to a newly constructed slab on grade adjacent to the new screen and structure, construction of a new wet well and triplex submersible influent pump station, installation of pipes, valves, and appurtenances, removal and replacement of existing ductile iron aeration piping with stainless steel piping, electrical, SCADA, and instrumentation and controls for the work described, site restoration including filling the pond to proposed grade, grassing, and other restoration. All work shall be performed in accordance with the plans and specifications.

ARTICLE III CONTRACT TIME

3.1 Time and Liquidated Damages

3.1.1 The Contractor shall commence the Work within ten (10) days upon receipt of the Notice to Proceed and shall Substantially Complete all Work within **One Hundred & Eighty (180)** consecutive calendar days. Final Completion shall be **Thirty (30)** consecutive calendar days after Substantial Completion.

The number of calendar days from the date on which the Work is permitted to proceed, through the date set forth for Final Completion, shall constitute the "Contract Time."

3.1.2 The Contractor shall pay the Owner the sum of **\$ 1,423.00** per day for each and every calendar day of unexcused delay in achieving Substantial Completion beyond the date set forth herein for Substantial Completion of the Work. Any sum's due and payable hereunder by the Contractor shall be payable, not as a penalty, but as liquidated damages representing an estimate of delay damages likely to be sustained by the Owner, estimated at or before the time of executing this Agreement. When the Owner reasonably believes that Substantial Completion shall be inexcusably delayed the Owner shall be entitled, but not required, to withhold from any amounts otherwise due the Contractor an amount then believed by the Owner to be adequate to recover liquidated damages applicable to such delays. If and when the Contractor overcomes the delay in achieving Substantial Completion, or any part thereof, for which the Owner has withheld payment, the Owner shall promptly release to the Contractor those funds withheld, but no longer applicable, as liquidated damages.

3.2 Substantial Completion

3.2.1 "Substantial Completion" shall mean that stage in the progression of the Work when the Work is sufficiently complete in accordance with this Agreement that the Owner can enjoy beneficial use or occupancy of the Work and can utilize the Work for its intended purpose.

3.3 Time is of the Essence

3.3.1 All limitations of time set forth in the Contract Documents are of the essence of this Agreement.

ARTICLE IV CONTRACT PRICE

4.1 The Contract Price

4.1.1 The Owner shall pay, and the Contractor shall accept, as full and complete payment for all the Work required herein a Lump Sum of **\$ Six Hundred & Three Thousand Dollars & XX/Cents (\$603,000.00)**. The sum set forth in the Paragraph 4.1 shall constitute the Contract Price, which shall not be modified except by Change Order as provided in this Agreement.

ARTICLE V PAYMENT OF THE CONTRACT PRICE

5.1 Schedule of Values

5.1.1 Within ten (10) calendar days of the effective date hereof, the Contractor shall submit to the Owner and to the Project Director a Schedule of Values allocating the Contract Price to the various portions of the Work. The Contractor's Schedule of Values shall be prepared in such form, with such detail, and supported by such data as the Project Director or the Owner may require to substantiate its accuracy. The Contractor shall not imbalance its Schedule of Values nor artificially inflate any element thereof. The violation of this provision by the Contractor shall constitute a material breach of this Agreement. The Schedule of Values shall be used only as a basis for the Contractor's Applications for Payment and shall only constitute such basis after it has been agreed upon in writing by the Project Director and the Owner. The Owner may terminate this Agreement without liability of any kind if the Schedule of Values is not agreed upon within fifteen (15) calendar days of the effective date hereof.

5.2 Payment Procedure

5.2.1 The Owner shall pay the Contract Price to the Contractor as provided below.

5.2.2 Progress Payments - On or before the fifteen (15) day of each month after commencement of the Work, the Contractor shall submit an Application for Payment for the period ending the thirtieth (30th) day of the previous month to the Project Director in such form and manner, and with such supporting data and content, as the Project Director may require. Therein, the Contractor may request payment based upon the amount of work done or completed. All partial estimates and payments shall be subject to correction when submitted. Based upon the Contractor's Applications for Payment submitted to the Project Director and upon Certificates for Payment subsequently issued to the Owner by the Project Director, payments will be made in accordance with the Local Government Prompt Payment Act.

5.2.3 The amount of such payments shall be the total value of the Work done to the date of the estimate, based upon the quantities and the Contract unit and/or lump sum prices, less an

amount retained and less payments previously made. The amount retained shall be determined in accordance with Section 255.078 of the Florida Statutes:

(a) Owner may withhold from each progress payment made to the Contractor an amount not to exceed ten (10) percent of the payment as retainage until fifty (50) percent completion of the Work.

(b) After fifty (50) percent completion of the Work is purchased pursuant to this Agreement, Owner will reduce to five (5) percent the amount of retainage withheld from each subsequent progress payment made to the Contractor. The term "fifty (50) percent completion" as used in this provision means the point at which Owner has expensed fifty (50) percent of the total cost of the Work purchased as provided herein, together with all costs associated with existing change orders and other additions or modifications to the Work described herein.

(c) After fifty (50) percent completion of the Work is purchased pursuant to this Agreement, the Contractor may present to the Owner a payment request for up one-half of the retainage held by the Owner. The Owner shall make prompt payment to the Contractor, unless in accordance with Section 255.078(6) of the Florida Statutes, such funds are the subject of a good faith dispute, claim or demand by the Owner or the Contractor.

5.2.4 Each Application for Payment shall be signed by the Contractor and shall constitute the Contractor's representation that the Work has progressed to the level for which payment is requested that the Work has been properly installed or performed in full accordance with this Agreement, and that the Contractor knows of no reason why payment should not be made as requested. Thereafter, the Project Director and Engineer shall review the Application for Payment and may also review the Work at the project site or elsewhere to determine whether the quantity and quality of the Work is as represented in the Application for Payment and is as required by this Agreement. The Project Director shall determine and certify to the Owner the amount properly owing to the Contractor. The Owner shall make partial payments on accounts of the Contract Price within thirty (30) days following the Project Director's receipt of each Application for Payment. The amount of each partial payment shall be the amount certified for payment by the Project Director less such amounts, if any, otherwise owing by the Contractor to the Owner or which the Owner shall have the right to withhold as authorized by this Agreement. The Project Director's certification of the Contractor's Application for Payment shall not preclude the Owner from the exercise of any of its rights as set forth in Paragraph 5.3 herein below.

5.2.4 The Contractor warrants that title to all Work covered by an Application shall pass to the Owner no later than time of payment. The Contractor further warrants that upon submittal of an Application for Payment, all Work for which payments have been received from the Owner shall be free and clear of liens, claims, security interest or other encumbrances in favor of the Contractor or any other person or entity whatsoever.

5.2.5 The Contractor shall promptly pay each Subcontractor out of the amount paid to the Contractor on account of such Subcontractor's Work, the amount to which such Subcontractor is entitled. In the event the Owner becomes informed that the Contractor has not paid a Subcontractor as herein provided, the Owner shall have the right, but not the duty, to issue future checks in payment to the Contractor of amounts otherwise due hereunder naming the Contractor and such Subcontractor as joint hereunder naming the Contractor and such Subcontractor as joint payees. Such joint check procedure, if employed by the Owner, shall create no rights in favor of any person or entity beyond the right of the named payees to payment of the check and shall not be deemed to commit the Owner to repeat the procedure in the future.

5.2.6 No progress payment, nor any use or occupancy of the Project by the Owner, shall be interpreted to constitute an acceptance of any Work not in strict accordance with this Agreement.

5.3 Withheld Payment

5.3.1 Owner may decline to make payment, may withhold funds and, if necessary, may demand the return of some or all of the amounts previously paid to the Contractor, to protect the Owner from loss because of:

- a) defective Work not remedied by the Contractor and, in the opinion of the Owner, not likely to be remedied by the Contractor;
- b) claims of third parties against the Owner or the Owner's property;
- c) failure by the Contractor to pay Subcontractors or others in a prompt and proper fashion;
- d) evidence that the balance of the Work cannot be completed in accordance with the Contract for unpaid balance of the Contract Price;
- e) evidence that the Work shall not be completed in the time required for Substantial or Final Completion;
- f) persistent failure to carry out the Work in accordance with the Contract;
- g) damage to the Owner or a third party to whom the Owner is, or may be, liable.

In the event that the Owner makes written demand upon the Contractor for amounts previously paid by the Owner as contemplated in this Subparagraph 5.3.1, the Contractor shall promptly comply with such demand.

5.4 Unexcused Failure to Pay

5.4.1 If within ten (10) days after the date established herein for payment to the Contractor by the Owner, the Owner, without cause or basis hereunder, fails to pay the Contractor any amount due and payable to the Contractor, then the Contractor may after seven (7) additional days, written notice to the Owner and the Project Director, and without prejudice to any other available rights or remedies it may have, stop the Work until payment of those amounts due from the Owner have been received. Any payment not made within ten (10) days after the date due shall bear interest at the rate of 12 percent (12%) per annum.

5.5 Substantial Completion

5.5.1 When the Contractor believes the Work is Substantially Complete, the Contractor shall submit to the Project Director a list of items to be completed or corrected. When the Project Director on the basis of an inspection determines that the Work is in fact Substantially Complete, he shall prepare a Certificate of Substantial Completion which shall establish the date of Substantial Completion, shall state the responsibilities of the Owner and the Contractor for Project security, maintenance, heat, utilities, damage to the Work, and insurance, and shall fix the time within which the Contractor shall complete the items listed therein. Guarantees required by the Contract shall commence on the date of Substantial Completion of the Work. The Certificate of Substantial Completion shall be submitted to the Owner and the Contractor for their written acceptance of the responsibilities assigned to them in such certificate.

Until Final Completion and acceptance of the Work by the Owner, the Owner shall pay the Contractor an amount equal to ninety percent (90%) of the Contract price. Ten Percent (10%) of the Contract Price shall be retained until Final Completion, acceptance of the Work by the Owner and Final Payment to the Contractor.

5.6 Final Completion and Final Payment

5.6.1 When all the Work is finally complete and the Contractor is ready for a Final Inspection, it shall notify the Owner and the Project Director thereof in writing. Thereupon, the Project Director shall make Final Inspection of the Work and, if the Work is complete in full accordance with this Agreement and this Agreement has been fully performed, the Project Director shall promptly

issue a Final Certificate for Payment and if required to repeat its Final Inspection of the Work, the Contractor shall bear the cost of such repetition of the Work, the Contractor shall bear the cost of such repeat Final Inspection(s) which cost may be deducted by the Owner and all other Authorities having jurisdiction under Florida Laws or regulations.

5.6.1.1 If the Contractor fails to achieve Final Completion within the time fixed therefore by the Engineer in its Certificate of Substantial Completion, the Contractor shall pay the Owner liquidated damages at the sum shown in Paragraph 3.1.2. per day for each and every calendar day of unexcused delay in achieving Final Completion beyond the date set forth herein for Final Completion of the Work. Any sum's due and payable hereunder by the Contractor shall be payable, not as penalty, but as liquidated damages representing an estimate of delay damages likely to be sustained by the Owner, estimated at or before the time of executing the Contract. When the Owner reasonably believes that Final Completion shall be inexcusably delayed, the Owner shall be entitled, but not required, to withhold from any amounts otherwise due the Contractor an amount then believed by the Owner to be adequate to recover liquidated damages applicable to such delays. If and when the Contractor overcomes the delay in achieving Final Completion, or any part thereof, for which the Owner has withheld payment, the Owner shall promptly release to the Contractor those funds withheld, but no longer applicable, as liquidated damages.

5.6.2 The Contractor shall not be entitled to Final Payment unless and until it submits to the Project Director its affidavit that all payrolls, invoices for materials and equipment, and other liabilities connected with the Work for which the Owner, or the Owner's property might be responsible, have been fully paid or otherwise satisfied; releases and waivers of claims and lien from all Subcontractors of the Contractor and of any and all other parties required by the Project Director or the Owner; consent of Surety, if any, to Final Payment. If any third party fails or refuses to provide a release of claim or waiver of a lien as required by Owner the Contractor shall furnish a bond satisfactory to the Owner to discharge any such lien or indemnify the Owner from liability.

5.6.3 The Owner shall make Final Payment of all sums, due the Contractor within thirty (30) days of the Project Director's execution of a Final Certificate for Payment.

5.6.4 Acceptance of Final Payment shall constitute a waiver of all claims against the Owner by the Contractor except for those claims previously made in writing against the Owner by the Contractor, pending at the time of Final Payment, and identified in writing by the Contractor as unsettled at the time of its request for Final Payment.

ARTICLE VI THE OWNER

6.1 Information, Services and Things Required from Owner

6.1.1 The Owner shall furnish to the Contractor, at the time of executing this Agreement, any and all written and tangible material in its possession concerning conditions below ground at the site of the Project. Such written and tangible material is furnished to the Contractor only in order to make complete disclosure of such material and for no other purpose. By furnishing such material, the Owner does not represent, warrant, or guarantee its accuracy either in whole, in part, implicitly, or at all, and shall have no liability therefore. The Owner shall also furnish surveys, legal limitations and utility locations (if known), and a legal description of the Project site. Copies may be provided instead of originals.

6.1.2 Excluding permits and fees normally the responsibility of the Contractor, the Owner shall obtain all approvals, easements, and the like required for construction.

6.1.3 The Owner shall furnish the Contractor, free of charge, 5 copies of the Contract

Documents for execution of the Work. The Contractor shall be charged, and shall pay the Owner \$25.00 per additional set of Contract Documents which it may require.

6.2 Right to Stop Work

6.2.1 If the Contractor persistently fails or refuses to perform the Work in accordance with this Agreement, the Owner may order the Contractor to stop the Work, or any described portion thereof, until the cause for stoppage has been corrected, no longer exists, or the Owner orders that Work be resumed. In such event, the Contractor shall immediately obey such order.

6.3 Owner's Right to Perform Work

6.3.1 If the Contractor's Work is stopped by the Owner under Paragraph 6.2, and the Contractor fails within seven (7) days of such stoppage to provide adequate assurance to the Owner that the cause of such stoppage shall be eliminated or corrected, the Owner may, without prejudice to any other rights or remedies the Owner may have against the Contractor, proceed to carry out the subject Work.

In such a situation, an appropriate Change Order shall be issued deducting from the Contract Price the cost of correcting the subject deficiencies, and compensation for the Owner's additional services and expenses necessitated thereby, if any. If the unpaid portion of the Contract Price is insufficient to cover the amount due the Owner, the Contractor shall pay the difference to the Owner.

ARTICLE VII THE CONTRACTOR

7.1 The Contractor is again reminded of its continuing duty set forth in Subparagraph 1.5.7. The Contractor shall perform no part of the Work at any time without adequate Contract Documents or, as appropriate, approved Shop Drawings, Product Data or Samples for such portion of the Work. If the Contractor performs any of the Work where Contractor knows or should know such work involves a recognized error, inconsistency or omission in the Contract Documents without such notice to the Project Director and the Owner, the Contractor shall bear responsibility for such performance and shall bear the cost of correction.

7.2 The Contractor shall perform the Work strictly in accordance with this Agreement.

7.3 The Contractor shall supervise and direct the Work using the Contractor's best skill, effort and attention. The Contractor shall be responsible to the Owner for any and all acts or omissions of the Contractor, its employees and other engaged in the Work on behalf of the Contractor.

7.4. Warranty

7.4.1 The Contractor warrants to the Owner that all labor furnished to progress the Work under this Agreement shall be competent to perform the tasks undertaken, that the product of such labor shall yield only first-class results, that materials and equipment furnished shall be of good quality, free from faults and defects and in strict conformance with this Agreement. This warranty shall survive termination of this Agreement and shall not be affected by Final Payment hereunder. All Work not conforming to these requirements may be considered defective.

7.5 Contractor shall obtain and pay for all permits, fees and licenses necessary and ordinary for the Work. The Contractor shall comply with all lawful requirements applicable to the Work and shall give and maintain any and all notices required by applicable law pertaining to the Work.

7.6 Supervision

7.6.1 The Contractor shall employ and maintain at the Project site only competent supervisory personnel. Absent written instruction from the Contractor to the contrary, the superintendent shall be deemed the Contractor's authorized representative at the site and shall be authorized to receive and accept any and all communications from the Owner or Assignees.

7.6.2 Key supervisory personnel assigned by the Contractor to this Project are as follows:

Name	Function
_____	_____
_____	_____
_____	_____

So long as the individuals named above remain actively employed or retained by the Contractor, they shall perform the functions indicated next to their names unless the Owner agrees to the contrary in writing. In the event one or more individuals not listed above subsequently assume one or more of those functions listed above, the Contractor shall be bound by the provisions of this Subparagraph 7.6.2 as though such individuals have been listed above.

7.7 The Contractor, prior to commencing the Work, shall submit to the Project Director for his information, the Contractor's schedule for completing the Work. The Contractor's schedule shall be revised no less frequently than monthly (unless the parties otherwise agree in writing) and shall be revised to reflect conditions encountered from time to time and shall be related to the entire Project. Each sum revision shall be furnished to the Project Director. Failure by the Contractor to strictly comply with the provisions of this Paragraph 7.7 shall constitute a material breach of this Agreement.

7.8 The Contractor shall continuously maintain at the site, for the benefit of the Project Director, one record copy of this Agreement marked to record on a current basis changes, selections and modifications made during construction. Additionally, the Contractor shall maintain at the site for the Project Director

the approved Product Data, Samples and other similar required submittals. Upon Final Completion of the Work, all of these record documents shall be delivered to the Owner.

7.9 Product Data and Samples

7.9.1 Product Data, Samples and other submittals from the Contractor do not constitute Contract Documents. Their purpose is merely to demonstrate the manner in which the Contractor intends to implement the Work in conformance with the information received from the Contract Documents. All Product Data, Samples and other submittals shall belong to the Owner and shall be delivered, or returned to Owner, as applicable, prior to Submittals shall belong to Owner and shall be delivered, or returned to Owner, as applicable, prior to Substantial Completion.

7.10 Cleaning the Site and the Project

7.10.1 The Contractor shall keep the site reasonably clean during performance of the Work. Upon Final Completion of the Work, the Contractor shall clean the site and the Project and remove all waste, together with all of the Contractor's property therefrom.

7.11 Access to Work

7.11.1 The Owner and the Project Director shall have access to the Work at all times from commencement of the Work through Final Completion. The Contractor shall take whatever steps

necessary to provide access when requested.

7.12 Indemnity

7.12.1 To the fullest extent permitted by law, the Contractor shall indemnify and hold harmless the Owner, employees and officials from, and against, any, and all, administrative/legal/equitable liability, claims, damages, losses and expenses, including attorneys' fees, arising out of or resulting from performance of the work, noted in either the Scope of Work, or the Contract Documents, that are referenced and considered a part of this Agreement. It is specifically noted that such liability, claims, damages, loss or expense includes any of those referenced instances attributable to bodily injury, sickness, disease, or death, or to injury to, or destruction of, personal and/or real property, including the loss of use resulting therefrom or incident to, connected with, associated with or growing out of direct and/or indirect negligent or intentional acts or omissions by the Contractor, a Subcontractor, or anyone directly, or indirectly employed by them, or anyone for whose acts the Contractor or Subcontractor may be liable, regardless of whether or not such liability, claim, damage, loss or expense is caused in part by a party indemnified hereunder.

7.12.2 In claims against any person or entity indemnified under this Paragraph 7.12 by an employee of the Contractor, a Subcontractor, any one directly or indirectly employed by them or anyone for whose acts they may be liable, the indemnification obligation under this Paragraph 7.12 shall not be limited by a limitation on amount or type of damages, compensation or benefits payable by or for the Contractor or a Subcontractor under workers' compensation acts, disability benefits acts or other employee benefit acts.

7.13 Safety

7.13.1 The Contractor shall be responsible for supervising all safety precautions, including initiating and maintaining such programs in connection with the performance of the Contract and for adequate maintenance of traffic.

7.13.2 The Contractor shall designate a member of the on site construction team whose duty shall be the prevention of accidents. Unless notified otherwise in writing by the Contractor to the Owner and the Engineer, this person shall be the Contractor's Superintendent.

ARTICLE VIII CONTRACT ADMINISTRATION

8.1 Project Director

8.1.1 The Project Director, unless otherwise directed by the Owner shall perform those duties and discharge those responsibilities allocated to the Project Director as set forth in this Agreement. The Project Director shall be the Owner's representative from the effective date of this Agreement until Final Payment has been made. The Project Director shall be authorized to act on behalf of the Owner only to the extent provided in this Agreement.

8.1.2 The Owner and the Contractor shall communicate with each other in the first instance through the Project Director.

8.1.3 The Project Director shall be the initial interpreter of the requirements of the drawings and specifications and the judge of the performance there under by the Contractor. The Project Director shall render written or graphic interpretations necessary for the proper execution or progress of the Work with reasonable promptness on request of the Contractor.

8.1.4 The Project Director shall review the Contractor's Applications for Payment and shall certify to the Owner for payment to the Contractor, those amounts then due to the Contractor as

provided in this Agreement.

8.1.5 The Project Director shall have authority to reject Work, which is defective or does not conform to the requirements of this Agreement. If the Project Director deems it necessary or advisable, the Project Director shall have authority to require additional inspection or testing of the Work for compliance with Contract requirements at Contractor's expense.

8.1.6 The Project Director shall review and approve, or take other appropriate action as necessary, concerning the Contractor's submittals including Product Data and Samples. Such review, approval or other action shall be for the sole purpose of determining conformance with the design concept and information given through the Contract Documents.

8.1.7 The Project Director shall prepare Change Orders and may authorize minor changes in the Work by field order as provided elsewhere herein.

8.1.8 The Project Director shall, upon written request from the Contractor, conduct inspections to determine the date of Substantial Completion and the date of Final Completion, shall receive and forward to the Owner for the Owner's review and records, written warranties and related documents required by this Agreement and shall issue a Final Certificate for Payment upon compliance with the requirements of this Agreement.

8.1.9 The Project Director's decision in matters relating to aesthetic effect shall be final if consistent with the intent of this Agreement.

8.2 Claims by the Contractor

8.2.1 All Contractor claims shall be initiated by written notice and claim to the Project Director. Such written notice and claims must be furnished within seven (7) days after occurrence of the event, or the first appearance of the condition, giving rise to the claim.

8.2.2 Pending final resolution of any claim of the Contractor, the Contractor shall diligently proceed with performance of this Agreement and the Owner shall continue to make payments to the Contractor in accordance with this Agreement. The resolution of any claim under this Paragraph 8.2 shall be reflected by a Change Order executed by the Project Director and the Contractor.

8.2.3 Claims for Concealed and Unknown Conditions - Should concealed and unknown conditions encountered in the performance of the Work (a) below the surface of the ground or (b) in an existing structure be at variance with the conditions indicated by this Agreement, or should unknown conditions of an usual nature differing materially from those ordinarily encountered in the area and generally recognized as inherent in Work of the character provided for in this Agreement, be encountered, wherein the Contract Documents or Standard Construction industry practices have not placed the responsibility of discovering such concealed and unknown conditions upon the Contractor prior to the Contractor submitting his Bid for the Work, the Contract Price shall be equitably adjusted by Change Order upon the written notice and claim by either party made within seven (7) days after the first observance of the condition. As a condition precedent to the Owner having any liability to the Contractor for concealed or unknown conditions, the Contract must give the Project Director written notice of, and an opportunity to observe, the condition prior to disturbing it. The failure by the Contractor to make the written notice and claim as provided in this Subparagraph shall constitute a waiver by the Contractor of any claim arising out of or relating to such concealed or unknown condition.

8.2.4 Claims for Additional Costs - If the Contractor wishes to make a claim for an increase in the Contract Price, as a condition precedent to any liability of the Owner therefore, the Contractor shall give the Project Director written notice of such claim within seven (7) days after the occurrence of the event, or the first appearance of the condition, giving rise to such claim. Such

notice shall be given by the Contractor before proceeding to execute any additional or changed Work. The failure by the Contractor to give such notice prior to executing the Work shall constitute a waiver of any claim for additional compensation.

8.2.4.1 In connection with any claim by the Contractor against the Owner for compensation in excess of the Contract Price, any liability of the Owner for the Contractor's costs shall be strictly limited to direct costs incurred by the Contractor and shall in no event include indirect costs or consequential damages of the Contractor.

The Owner shall not be liable to the Contractor for claims of third parties, including Subcontractors, unless and until liability of the Contractor has been established therefore in a court of competent jurisdiction.

8.2.5 Claims for Additional Time - If the Contractor is delayed in progressing any task which at the time of the delay is then critical or which during the delay becomes critical, as the sole result of any act or neglect to act by the Owner or someone acting in the Owner's behalf, or by changes ordered in the Work, unusual delay in transportation, unusually adverse weather conditions not reasonably anticipated, fire or any causes beyond the Contractor's control, then the date for achieving Substantial Completion of the Work shall be extended upon the written notice and claim of the Contractor to the Project Director, for such reasonable time as the Project Director may determine.

Any notice and claims for an extension of time by the Contractor shall be made not more than seven (7) days after the occurrence of the event or the first appearance of the condition giving the rise to the claim and shall set forth in detail the Contractor's basis for requiring additional time in which to complete the Project. In the event the delay to the Contractor is continuing one, only one notice and claim for additional time shall be necessary. If the Contractor fails to make such claim for an extension shall be waived. This paragraph shall not be deemed to waive any damages for delay that are covered by insurance.

8.2.5.1 Delays and Extensions of Time - An extension of Contract Time shall not be given due to weather conditions unless such weather conditions more severe than average have caused a delay. In requesting extension of time for weather conditions; Contractor shall present complete records and such requests shall document how weather conditions delayed progress of Work.

8.3 Field Orders

8.3.1 The Project Director shall have authority to order minor changes in the Work not involving a change in the Contract Price or in Contract Time and not inconsistent with the intent of the Contract. Such changes shall be effected by field order and shall be binding upon the Contractor. The Contractor shall carry out such field orders promptly.

ARTICLE IX SUBCONTRACTORS

9.1 Definition

9.1.1 A Subcontractor is an entity, which has a direct Contract with the Contractor to perform a portion of the Work.

9.2 Award of Subcontracts

9.2.1 Upon execution of the Contract, the Contractor shall furnish the Project Director, in writing, the names of persons or entities proposed by the Contractor to act as a Subcontractor on the Project (See Attachment B attached to this agreement). The Project Director shall promptly reply to the Contractor, in writing, stating any objections the Project Director may have to such proposed Subcontractor. The Contractor shall not enter into a Subcontract with a proposed

Subcontractor with reference to whom the Project Director has made a timely objection.

9.2.2 All subcontracts shall afford the Contractor rights against the Subcontractor, which correspond to those rights afforded to the Owner by Subparagraph 12.2.1 below.

ARTICLE X CHANGES IN THE WORK

10.1 Changes Permitted

10.1.1 Changes in the Work within the general scope of this Agreement, consisting of additions, deletions, revisions, or any combination thereof, may be ordered without invalidating this Agreement, by Change Order or by Field Order.

10.1.2 Changes in the Work shall be performed under applicable provisions of this Agreement and the Contractor shall proceed promptly with such changes.

10.2 Change Order Defined

10.2.1 Change Order shall mean a written order to the Contractor executed by the Project Director, issued after execution of this Agreement, authorizing and directing a change in the Work or an adjustment in the Contract Price or the Contract Time, or any combination thereof. Only the Change Order may change the Contract Price and the Contract Time.

10.3 Changes in the Contract Price

10.3.1 Any change in the Contract Price resulting from a Change Order shall be determined as follows: (a) by mutual agreement between the Owner and the Contractor as evidenced by (1) the change in the Contract Price being set forth in the Change Order, (2) such change in the Contract Price, together with any conditions or requirements related thereto, being initialed by both parties and (3) the Contractor's execution of the Change Order, or (b) if no mutual agreement occurs between the Owner and the Contractor, then, as provided in Subparagraph 10.3.2 below.

10.3.2 If no mutual agreement occurs between the Owner and the Contractor as contemplated in Subparagraph 10.3.1 above, the change in the Contract Price, if any, shall than be determined by the Project Director on the basis of the reasonable expenditures or savings of those performing, deleting or revising the Work attributable to the change, including, in the case of an increase or decrease in the Contract Price, a reasonable allowance for direct job site overhead and profit. In such case, the Contractor shall present, in such form and with such content as the Owner or the Project Director requires, an itemized accounting of such expenditures or savings shall be limited to the following: reasonable costs of materials, supplies, or equipment including delivery costs, reasonable costs of labor, including social security, old age and unemployment insurance, fringe benefits required by a pre-existing agreement or by custom, and workers' compensation insurance, reasonable costs of premiums for all Bonds and insurance, permit fees, and sales, use or other taxes related to the Work and paid by the Contractor, and reasonable costs of directly attributable to the change. In no event shall any expenditure or savings associated with the Contractor's home office or other non-jobsite overhead expenses be included in any change in the Contract Price. Pending final determination of reasonable expenditures or savings to the Owner, payments on account shall be made to the Contractor on the Owner's Certificate of Payment.

10.3.3 If Unit Prices are provided in the Contract, and if the quantities contemplated are so changed in proposed Change Order that application of such Unit Prices to the quantities of Work proposed shall cause substantial inequity to the Owner or to the Contractor, that applicable Unit Prices shall be equitable adjusted.

10.4 Minor Changes

10.4.1 The Project Director shall have authority to order minor changes in the Work not involving a change in the Contract Price or an extension of the Contract Time and not inconsistent with the intent of this Agreement. Such minor changes shall be made by written Field Order, and shall be binding upon the Owner and the Contractor. The Contractor shall promptly carry out such written Field Orders.

10.5 Effect of Executed Change Order

10.5.1 The execution of a Change Order by the Contractor shall constitute conclusive evidence of the Contractor's agreement to the ordered changes in the Work, this Agreement as thus amended, the Contract Price and the Contract Time. The Contractor, by executing the Change Order, waives and forever releases any claim against the Owner for additional time or compensation for matters relating to or arising out of or resulting from the Work included within or affected by the executed Change Order.

10.6 Notice to Surety; Consent

10.6.1 The Contractor shall notify and obtain the timely consent and approval of the Contractor's surety with reference to all Change Orders if such notice, consent or approval is required by the Contractor's surety or by law. The Contractor's warranty to the Owner that the surety has been notified of and consents to, such Change Order and the surety shall be conclusively deemed to have been notified of such Change Order and to have expressly consented thereto.

ARTICLE XI UNCOVERING AND CORRECTING WORK

11.1 Uncovering Work

11.1.1 If any of the Work is covered contrary to the Project Director's request or to any provision of this Agreement, it shall, if required by the Project Director, be uncovered for the Project Director's inspection and shall be properly replaced at the Contractor's expense without change in the Contract Time.

11.1.2 If any of the Work is covered in a manner not described in Subparagraph 11.1.1 above, it shall, if required by the by the Project Director or Owner, be uncovered for the Project Director's inspection. If such Work conforms strictly to this Agreement, costs of uncovering and proper replacement shall by Change Order be charged to the Owner. If such Work does not strictly conform to this Agreement, the Contractor shall pay the costs of uncovering and proper replacement.

11.2 Correcting Work

11.2.1 The Contractor shall immediately proceed to correct Work rejected by the Project Director as defective or failing to conform to this Agreement. The Contractor shall pay all costs and expenses associated with correcting such rejected Work, including any additional testing and inspections, and reimbursement to the Owner for the Project Director's services and expenses made necessary thereby.

11.2.2 If within one (1) year after Substantial Completion of the Work, if any of the Work is found to be defective or not in accordance with this Agreement, the Contractor shall correct it within seven (7) days at the Contractor's expense upon receipt of written notice from the Owner. This obligation shall survive Final Payment by the Owner and termination of this Agreement. With respect to Work first performed and completed after Substantial Completion, this one (1) year

obligation to specifically correct defective and nonconforming Work shall be extended by the period of time which elapses between Substantial Completion and completion of the subject Work.

11.2.3 Nothing contained in this Paragraph 11.2 shall establish any period of limitation with respect to other obligations, which the Contractor has under this Agreement. Establishment of the one (1) year time period in Subparagraph 11.2.2 relates only to the duty of the Contractor to specifically correct the Work, and has no relationship to the time which the obligation to comply with the Contract Documents may be sought to be enforced.

11.3 Owner May Accept Defective or Nonconforming Work

11.3.1 If the Owner chooses to accept defective or nonconforming Work, the Owner may do so. In such events, the Contract Price shall be reduced by the greater of (a) the reasonable cost of removing and correcting the defective or nonconforming Work, and (b) the difference between the fair market value of the Project had it not been constructed in such manner as to include defective or nonconforming Work. If the remaining portion of the unpaid Contract Price, if any, is insufficient to compensate the Owner for its acceptance or defective or nonconforming Work, the Contractor shall, upon written demand from the Owner, pay the Owner such remaining compensation for accepting defective or nonconforming Work.

ARTICLE XII CONTRACT TERMINATION

12.1 Termination by the Contractor

12.1.1 If the Work is stopped for a period of ninety (90) days by an order of any court or as a result of an act of the Government, through no fault of the Contractor or any person or entity working directly or indirectly for the Contractor, the Contractor may, upon ten (10) days written notice to the Owner, terminate performance under this Agreement and recover from the Owner payment for the actual reasonable expenditures of the Contractor (as limited in Subparagraph 10.3.2 above) for all Work executed and for materials, equipment, tools, construction equipment and machinery actually purchased or rented solely for the Work, less any salvage value of any such items.

12.1.2 If the Owner shall persistently or repeatedly fail to perform any material obligation to the Contractor for a period of fifteen (15) days after receiving written notice from the Contractor of its intent to terminate if such failure is not substantially corrected within fifteen (15) days, the Contractor may terminate performance under this Agreement by written notice to the Project Director. In such event, the Contractor shall be entitled to recover from the Owner as though the Owner had terminated the Contractor's performance under this Agreement for convenience pursuant to Subparagraph 12.2.1 hereunder.

12.2 Termination by the Owner

12.2.1 For Convenience

12.2.1.1 The Owner may terminate this Agreement for convenience. In such instance, the Owner shall provide written notice of such termination to the Contractor specifying when termination shall become effective.

12.2.1.2 The Contractor shall incur no further obligations in connection with the Work and the Contractor shall stop Work when such termination becomes effective. The Contractor shall also terminate outstanding orders and subcontracts. The Contractor shall settle liabilities and claims arising out of the termination of subcontracts and orders. The Owner may direct the Contractor to

assign the Contractor's right, title and interest under terminated orders or subcontracts to the Owner or its designee.

12.2.1.3 The Contractor shall transfer title and deliver to the Owner such completed or partially completed Work and materials, equipment, parts, fixtures, information and Contract rights as the Contractor has.

- 12.2.1.4 (a) The Contractor shall submit a termination claim to the Project Director specifying the amounts due because of the termination for convenience together with costs, pricing or other data required by the Project Director. If the Contractor fails to file a termination claim within one (1) year from the effective date of termination, the Owner shall pay the Contractor, an amount derived in accordance with subparagraph (c) below.
- (b) The Owner and the Contractor may agree to compensation, if any, due to the Contractor hereunder.
- (c) Absent agreement to the amount due to the Contractor, the Owner shall pay the Contractor the following amounts;
- (d) Contract prices for labor, materials, equipment, and other services accepted under this Agreement;
- (e) Reasonable costs incurred in preparing to perform and in performing a portion of the Work prior to termination and not included in (d) or (e), and in terminating the Contractor's performance, plus a fair and reasonable allowance for overhead and profit thereon (such profit shall not include anticipated profit or consequential damages); provided, however, that if it appears that the Contractor would have not profited or would have sustained a loss if the entire Contract had been completed, no profit shall be allowed or included and the amount of compensation shall be reduced to reflect the anticipated rate of loss, if any;
- (f) Reasonable costs of settling and paying claims arising out of the termination of Subcontracts or orders pursuant to Subparagraph 12.2.1.2 of this Paragraph. These costs shall not include amounts paid in accordance with other provisions hereof.

The total sum to be paid the Contractor under this Subparagraph 12.2.1 shall not exceed the total Contract Price, as properly adjusted, reduced by the amount of payments otherwise made, and shall in no event include duplication of payment.

12.2.2 For Cause

12.2.2.1 If the Contractor persistently or repeatedly refuses or fails to perform the Work in a timely manner, supply enough properly skilled Workers, supervisory personnel or proper equipment or materials, or if it fails to make prompt payment to Subcontractors, or for materials or labor, or persistently disregards laws, ordinances, rules, regulations or orders of any public authority having jurisdiction, or otherwise substantially violates a material provision of this Agreement, then the Owner may, by written notice to the Contractor, without prejudice to any other right or remedy, terminate the employment of the Contractor and take possession of the site and of all materials, equipment, tools, construction equipment and machinery thereon owned by the Contractor and may finish the Work by whatever methods it may deem expedient. In such case, the Contractor shall not be entitled to receive any further payment until the Work is finished.

12.2.2.2. If the unpaid balance of the Contract Price less any liquidated damages due under this Agreement, exceeds the cost of finishing the Work, including compensation for the

Project Director's additional services and expenses made necessary thereby, such exceed the unpaid balance, the Contractor shall pay the difference to the Owner. This obligation for payment shall survive the termination of the Contract.

12.2.2.3 In the event the employment of the Contractor is terminated by the Owner for cause pursuant to Subparagraph 12.2.2 and it is subsequently determined by a Court of competent jurisdiction that such termination was without cause, such termination shall thereupon be deemed a Termination for Convenience under Subparagraph 12.2.1 and the provisions of Subparagraph 12.2.1 shall apply.

ARTICLE XIII INSURANCE

13.1 Contractor's Insurance:

The CONTRACTOR shall not commence work under this Contract until he/she has obtained all insurance required under this section and such insurance has been approved by the COUNTY. All insurance policies shall be issued by companies authorized to do business under the laws of the State of Florida. The CONTRACTOR shall furnish proof of Insurance to the COUNTY prior to the commencement of operations. The Certificate(s) shall clearly indicate the CONTRACTOR has obtained insurance of the type, amount, and classification as required by contract and that no material change or cancellation of the insurance shall be effective without thirty (30) days prior written notice to the COUNTY. **Certificates shall specifically include the COUNTY as Additional Insured for all lines of coverage except Workers' Compensation.** A copy of the endorsement must accompany the certificate. Compliance with the foregoing requirements shall not relieve the CONTRACTOR of its liability and obligations under this Contract.

Certificate Holder Address: St. Johns County, a political subdivision of the State of Florida
500 San Sebastian View
St. Augustine, FL 32084

The CONTRACTOR shall maintain during the life of this Contract, Comprehensive General Liability Insurance with minimum limits of \$1,000,000 per occurrence, \$2,000,000 aggregate, to protect the CONTRACTOR from claims for damages for bodily injury, including wrongful death, as well as from claims of property damages which may arise from any operations under this contract, whether such operations be by the CONTRACTOR or by anyone directly employed by or contracting with the CONTRACTOR.

The CONTRACTOR shall maintain during the life of the contract, Professional Liability or Errors and Omissions Insurance with minimum limits of \$1,000,000, if applicable.

The CONTRACTOR shall maintain during the life of this Contract, Comprehensive Automobile Liability Insurance with minimum limits of \$300,000 combined single limit for bodily injury and property damage liability to protect the CONTRACTOR from claims for damages for bodily injury, including the ownership, use, or maintenance of owned and non-owned automobiles, including rented/hired automobiles whether such operations be by the CONTRACTOR or by anyone directly or indirectly employed by a CONTRACTOR.

The CONTRACTOR shall maintain during the life of this Contract, adequate Workers' Compensation Insurance in at least such amounts as are required by the law.

In the event of unusual circumstances, the County Administrator or his designee may adjust these insurance requirements.

ARTICLE XIV MISCELLANEOUS

14.1 GOVERNING LAW AND VENUE

14.1.1 The Contract shall be governed by the laws of the State of Florida. Venue for any administrative and/or legal action arising under the Contract shall be St. Johns County, Florida.

14.2 Successors and Assigns

14.2.1 The Owner and Contractor bind themselves, their successors, assigns and legal representatives to the other party hereto and to successors, assigns and legal representatives of such other party in respect to covenants, agreements and obligations contained in this Agreement. The Contractor shall not assign this Agreement without written consent of the Owner.

14.3 Surety Bonds

14.3.1 The Contractor shall furnish a separate Public Construction Bond to the Owner. Such Bonds shall set forth a penal sum in an amount not less than the Contract Price. The Bond furnished by the Contractor shall incorporate by reference the terms of this Agreement as fully as though they were set forth verbatim in such Bonds. The Public Construction Bond shall provide that in the event the Contract Price is adjusted by Change Order executed by the Contractor. The Public Construction Bond furnished by the Contractor shall be in form suitable to the Owner and shall be executed by a Surety, or Sureties, reasonably suitable to the Owner.

14.4. Safety of Persons and Property

14.4.1 When existing utility lines shown on the Drawings are to be removed or relocated, the Contractor shall notify the Engineer in ample time for taking measures for prevention of the interruption of any required services prior to the beginning of operations. In the event that the Contractor damages any existing utility lines not shown on the Drawings, the location of which is not known to the Contractor report thereof shall be made immediately to the Engineer.

14.4.2 Locations of existing utility lines shown on the Drawings are based on the best information available to the Engineer, but shall not be considered exact either as to location or number of such lines.

14.4.3 Contractor shall protect utility lines constructed under terms of the agreement and those discovered or shown on Drawings to be existing. Damage occurring to utility lines due to Contractor's operations shall be repaired at no cost to the Owner.

**ARTICLE XV
EQUAL EMPLOYMENT OPPORTUNITY**

15.1 Contractor's Employment Opportunity

15.1.1 The Contractor and all Subcontractors shall not discriminate against any employee or applicant for employment because of race, religion, color, sex, national origin or age.

The Contractor shall take affirmative action to insure that applicants are employed, and that employees are treated during employment without regard to their race, religion, color, sex, national origin or age. Such action shall include, but not be limited to, the following: employment, upgrading, demotion or transfer, recruitment or recruitment advertisement, layoff or termination, rates of pay or other forms of compensation, and selection for training, including apprenticeship. The Contractor agrees to post in conspicuous places, available to employees and applicants for employment, notices setting forth the policies of non-discrimination.

15.1.2 The Contractor and all Subcontractors shall, in all solicitations or advertisements for employees placed by them or on their behalf, state that all qualified applicants shall receive consideration for employment without regard to race, religion, color, sex, national origin or age.

ARTICLE XVI APPRENTICESHIP LAW REQUIREMENTS

16.1 Apprenticeship Law (Chapter 446, Florida Statutes)

16.1.1 The Contractor shall make a diligent effort to hire for Performance of the Contract a number of apprentices in each occupation which bears to the average number of journeyman in that occupation to be employed in the performance of the Contract, the ratio of at least one (1) apprentice or trainee to every five (5) journeymen.

16.1.2 The Contractor shall, when feasible and except when the number of apprentices or trainees to be hired is fewer than four (4), assure that twenty-five (25) percent of such apprentices or trainees are in their first year of training. Feasibility here involves a consideration of the availability of training opportunities for first year apprentices or trainees, the hazardous nature of the Work for beginning workers, and excessive unemployment of apprentices or trainees in their second or subsequent years of training.

16.1.3 The Contractor, during the performance of the Contract, shall make diligent efforts to employ the number of apprentices or trainees necessary to meet requirements of Subparagraphs a. and b. However, on-the-job training programs shall only be established in non-apprenticable trades or occupations to meet the requirements of this section.

16.1.4 The Contractor agrees to return records of employment, by trade, of the number of apprentices or trainees by first year of training, and the number of journeymen and the wages paid, and hours of work, of such persons on a form as prescribed by the Bureau of Apprenticeship of the Division of Labor at three (3) month intervals. Submission of duplicate copies of forms submitted to the United States Department of Labor shall be sufficient compliance with the provisions of the section.

16.1.5 The Contractor agrees to supply the Bureau of Apprenticeship of the Division of Labor, at three (3) months intervals, a statement describing steps taken toward making diligent effort and containing a breakdown by craft or hours worked and wages paid for first year apprentices or trainees, other apprentices or trainees and journeymen.

16.1.6 The Contractor agrees to insert in any Subcontract under this Agreement the requirements contained in this section. "The term Contractor" as used in such clauses and any Subcontract shall mean the Subcontractor.

16.1.7 Anything herein to the Contrary notwithstanding, Contractor agrees to comply with all of the provisions of Florida Statutes 446 and all regulations prescribed by the Bureau of Apprenticeship of the Division of Labor.

ARTICLE XVII ACCESS TO RECORDS

17.1 Access To Records (Chapter 119, Florida Statutes)

17.1 The cost of reproduction, access to, disclosure, non-disclosure, or exemption of records, data, documents, and/or materials, associated with this Agreement shall be subject to the applicable provisions of the Florida Public Records Law (Chapter 119, Florida Statutes), and

other applicable State and Federal provisions. Access to such public records, may not be blocked, thwarted, and/or hindered by placing the public records in the possession of a third party, or an unaffiliated party.

17.2 In accordance with Florida law, to the extent that Contractor's performance under this Agreement constitutes an act on behalf of the County, the Contractor shall provide access to all public records made or received by Contractor in conjunction with this Agreement. Specifically, if Contractor is expressly authorized, and acts on behalf of the County under this Agreement, Contractor shall:

- (1) keep and maintain public records that ordinarily and necessarily would be required by the County in order to perform the services described herein;
- (2) provide the public with access to public records related to this Agreement on the same terms and conditions that the County would provide the records, and at a cost that does not exceed the costs provided in Chapter 119, Florida States, or as otherwise provided by applicable law;
- (3) ensure that public records related to this Agreement that are exempt or confidential and exempt from public disclosure are not disclosed except as authorized by applicable law; and
- (4) meet all requirements for retaining public records, and transfer at Contractor's sole cost and expense, all public records in the possession of Contractor upon termination of this Agreement. Contractor shall destroy any duplicate records that are exempt or confidential and exempt from public disclosure requirements in accordance with applicable State and Federal provisions. Any public records stored electronically must be provided to the County in a format that is compatible with information technology systems maintained by the County.

17.3 Failure by Contractor to grant such public access shall be grounds for immediate, unilateral termination of this Agreement by the County. Contractor shall promptly provide the County notice of any request to inspect or copy public records related to this Agreement in Contractor's possession and shall promptly provide the County a copy of Contractor's response to each such request.

ARTICLE XVIII REVIEW OF RECORDS

18.1 Review of Records

As a conditions of entering into this Agreement/Contract, and to ensure compliance, especially as it relates to any applicable law, rule, or regulation, the Contractor authorizes the County to examine, review, inspect, and/or audit the books and records, in order to determine whether compliance has been achieved with respect to the terms, conditions, provisions, rights, and responsibilities noted in this Agreement. It is specifically noted that the Contractor is under no duty to provide access to documentation not related to this Agreement, and/or is otherwise protected by County, State, or Federal law.

{Remainder of page intentionally left blank}

Contract No.: Bid No 14-105 Marsh Landing WWTP Influent Pump Station and Static Screen Improvements

Owner
St. Johns County _____ (Seal)

Contractor
Sawcross, Inc. (Seal)

(Typed Name)

(Typed Name)

By: _____

By _____

Signature

Signature

Printed Name & Title

Printed Name & Title

Date of Execution

Date of Execution

Cheryl Strickland, Clerk of Courts

By: _____
Deputy Clerk

Date of Execution

Legally Sufficient:

Senior Assistant County Attorney

Date: _____