

RESOLUTION NO. 2015 - 357

A RESOLUTION BY THE BOARD OF COUNTY COMMISSIONERS OF ST. JOHNS COUNTY, FLORIDA, AUTHORIZING THE COUNTY ADMINISTRATOR, OR DESIGNEE, TO PURCHASE AND TO EXECUTE A PURCHASE ORDER FOR TWO NEW 2015 BRAUN AMBULANCES

RECITALS

WHEREAS, the County seeks to purchase of two (2) 2015 Braun Ambulances; and

WHEREAS, in accordance with section 302.6.5.4 of the St. Johns County Purchasing Manual, entitled "Piggyback or Cooperative Purchasing", the County is authorized make said purchase subject to the terms and conditions of Florida Sheriff's Association, Florida Association of Counties & Florida Fire Chief's Association Contract #15-11-0116 ("Contract"); and

WHEREAS, purchase of the ambulances will be funded by the EMS Department and Fire impact Fees; and

WHEREAS, the County has reviewed the terms, provisions, conditions and requirements of the Contract and finds that entering into the Contract for purchase of the ambulances serves a public purpose.

NOW, THEREFORE BE IT RESOLVED BY THE BOARD OF COUNTY COMMISSIONERS OF ST. JOHNS COUNTY, FLORIDA, as follows:

Section 1. The above Recitals are incorporated by reference into the body of this Resolution and such Recitals are adopted as finds of fact.

Section 2. The County Administrator, or designee, is hereby authorized to purchase two (2) 2015 Braun Ambulances.

Section 3. In accordance with the terms and conditions of the Contract, the County Administrator, or designee, is further authorized to execute a purchase order in the amount of \$478,007.94 for purchase of the ambulances from Ten-8 Fire Equipment, Inc.

Section 4. To the extent that there are typographical and/or administrative errors that do not change the tone, tenor, or concept of this Resolution, then this Resolution may be revised without subsequent approval by the Board of County Commissioners.

PASSED AND ADOPTED by the Board of County Commissioners of St. Johns County, Florida, this 1 day of December, 2015.

**BOARD OF COUNTY COMMISSIONERS
OF ST. JOHNS COUNTY, FLORIDA**

By: [Signature]
Chair

ATTEST: Hunter S. Conrad, Clerk

By: [Signature]
Deputy Clerk

RENDITION DATE 12/3/15



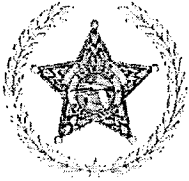

SEARCH

[About»](#) [Sheriffs»](#) [Legislative»](#) [Conferences»](#) [Training»](#) [Programs»](#) [Purchasing»](#) [Membership»](#) [Newsroom»](#)

[Resources»](#) [Store](#)

Cooperative Fleet

[Bid Announcements](#)

[Police Rated, Administrative, Utility Vehicles, Trucks & Vans Bid Award](#)

[Cab & Chassis & Other Fleet Equipment Bid Award](#)

[Fire Rescue/EMS Bid Award](#)

[Tire & Related Services Bid Award](#)

[Lease Programs](#)

[Fleet News](#)

[Dealer News](#)

[Manufacturer News](#)

[Archives](#)

[Dealers Only](#)

[Fleet Meetings & Conferences](#)

Share this page



Fire Rescue/EMS Bid Award

Bid Award Announcement 2014-2015

15-11-0116

Effective February 2, 2015 - March 31, 2016

[Bid Award](#)

[Bid Support Documents](#)

[Dealer Directory](#)

[Archive](#)

[Contract Terms and Conditions](#)

**FLORIDA SHERIFFS ASSOCIATION, FLORIDA FIRE CHIEFS'
ASSOCIATION, & FLORIDA ASSOCIATION OF COUNTIES**

*Effective dates for Bid 15-11-0116 are: February 1, 2015 through March 31, 2016.

SPECIFICATION #01 – TYPE I AMBULANCE
2 WHEEL DRIVE – 4 WHEEL DRIVE OPTIONAL
(DUAL REAR WHEEL, CAB & CHASSIS)

ALL ITEMS FACTORY INSTALLED UNLESS OTHERWISE INDICATED. The manufacturer supplied detailed build sheets are available for print and view via the links within the Awarded Bid Pricing Excel Spreadsheet.

1. ENGINE

- a. Turbo diesel engine, minimum 5.9L displacement.
- b. Must include the chassis manufacturer's "AMBULANCE PREP PACKAGE" which is intended to be an ambulance or components where available.
- c. Heavy-duty alternator, minimum 200 amp.
- d. Maintenance free heavy-duty batteries, 750 CCA minimum, Group 31, 2 battery minimum.
- e. Manufacturer's heavy-duty engine cooling.

2. TRANSMISSION

- a. Automatic transmission, 4 speed minimum with overdrive.
- b. Manufacturer's heavy-duty cooling.

3. AXLES

- a. Manufacturer's standard drive axle ratio for ambulance prep.

4. PERFORMANCE ITEMS

- a. Power steering
- b. Anti-lock brakes
- c. Power brakes, disc type front, disc or drum rear.
- d. Fuel capacity, 250 miles minimum without refueling
- e. Heavy-duty front and rear shocks.
- f. Front stabilizer bar.

5. COMFORT ITEMS

- a. Factory installed air conditioning
- b. Tinted glass (factory tint)
- c. Minimum seating for two
- d. Rubber floor mat instead of carpeting
- e. AM/FM radio
- f. Power door locks
- g. Power windows
- h. Speed control and tilt wheel.

6. SAFETY ITEMS

- a. Driver and passenger lap and shoulder belt with retractor.
- b. Driver and passenger air bags
- c. Dual electric horns
- d. Outside mirrors to provide vision for vehicles 96" wide.
- e. Two speed wipers with intermittent.
- f. Interior dome lights wired to right and left doors.

7. TIRES AND WHEELS

- a. BSW, all season tread radial 17 inch tires.
- b. Conventional spare tire and wheel
- c. Jack and wheel wrench

8. CHASSIS, FRAME, CAB

- a. Minimum GVWR 13,200 lbs.
- b. Cab and chassis only
- c. Cab to center of axle 84 inches, minimum

9. MODULAR BODY CONSTRUCTION

- a. The ambulance body and patient compartment shall be sufficient in size to meet the requirements of this specification and those of paragraph 3.10.1 of the current KKK-A-1822F.



November 3, 2015

Assistant Chief Jeff Prevatt
St. John's County Fire Service
3657 Gaines Road
St. Augustine, FL 32084

RE: (2) Two Braun 2016 Chief XL ambulances w/ Dodge 4500 Chassis

Chief Prevatt,

Thank you for your support of Ten-8 Fire Equipment and Braun Industries for the purchase of (2) two additional rescue/ambulances. We are pleased to offer the following proposal for your review and consideration.

PROPOSAL

(2) Two 2016 Braun Chief XL Type I Rescue/Ambulances on a 2016 Dodge 4500 Chassis per your current design and FSA Bid 15-11-0116 Effective Feb. 2,2015- March 31, 2016

\$174,097.00	Base Price
\$17,919.97	Loose Equipment (Stretcher, Truck Kit)
\$40,987.00	Ambulance Options
<u>\$6,000.00</u>	Change #8 Stryker Cot Retention requirement
Total	\$239,003.97

Unit Price: \$239,003.97 Total: \$ 239,003.97 x 2 = \$478,007.94

VEHICLE COMPLETION: 130 days from receipt of chassis

Terms: US Currency Due: Upon Delivery FOB: St. Augustine, Florida

We appreciate the opportunity to serve you again by providing two (2) new Braun rescue/ambulances. Should you have any additional questions, comments or requests please feel free to contact me. We look forward to working with you again.

Sincerely,
Wayne Stowell
Wayne Stowell
727-746-7442

Ten-8 Fire Equipment
2904 59th Ave. Dr. E.
Bradenton, FL 34203
www.ten8fire.com



St. John's County Fire Rescue
 Options List for (2) New Ambulances
 Two (2) 2016 Braun Chief XL Type I Rescue/Ambulances on a 2016 Ram
 4500 chassis and FSA Bid 15-11-0116 Effective Feb. 2, 2015 - March 31, 2016

1. Custom Map Console	\$789.00
2. Map Light	\$105.00
3. 3 Batteries with slide out tray	\$350.00
4. 12v Buss bars	\$350.00
5. Shoreline Twistlock ILO	\$125.00
6. Additional Shoreline	\$305.00
7. Upgrade to LED emergency lighting	\$1295.00
8. Clock	\$175.00

9. Rear window sliding	\$75.00
10. Compartment rope lighting	\$550.00
11. Transverse compartments for backboard storage	\$870.00
12. O2 slide out tray	\$1593.00
13. Additional compt. dividers	\$325.00
14. Vanner inverter	\$1508.00
15. Camera system	\$755.00
16. Interior LED lights	\$985.00

17. Pull out trays	\$325.00
18. Additional exterior trays	\$1855.00
19. SCBA mounting plates and brackets	\$1050.00
20. Power door locks	\$2100.00
21. Norcold refrigerator	\$1762.00
22. Hoseline upgrade AC/Heat system	\$7413.00
23. LP bracket	\$ 230.00
24. External condenser with brush guard	\$1300.00

25. EVS child safety seat	\$500.00
26. Medivault cabinet	\$1379.00
27. Two tone paint red/white	\$1950.00
28. Graphics including chevron	\$2253.00
29. Cot retention system per GSA change #8	\$6,000.00
30. Loose equipment (stretcher, axe, etc.)	\$17,919.97
31. Liquid Spring suspension	\$3050.00

32. Aluminum rims for chassis	\$1200.00
33. Air horns mounted under the bumper	\$1250.00
34. Running board lights	\$198.00
35. Custom interior cabinetry	\$3017.00
40. FSA Base price Chief XL with 2016 Ram chassis	\$174,097.00

Grand Total \$239,003.97 x 2 = \$478,007.94

DIMENSIONS FOR OVERALL HEIGHT AND LENGTH ARE APPROXIMATE
 OVERALL HEIGHT = 110"
 OVERALL WIDTH WITH RUB
 RAILS & FENDERLETTS = 98"

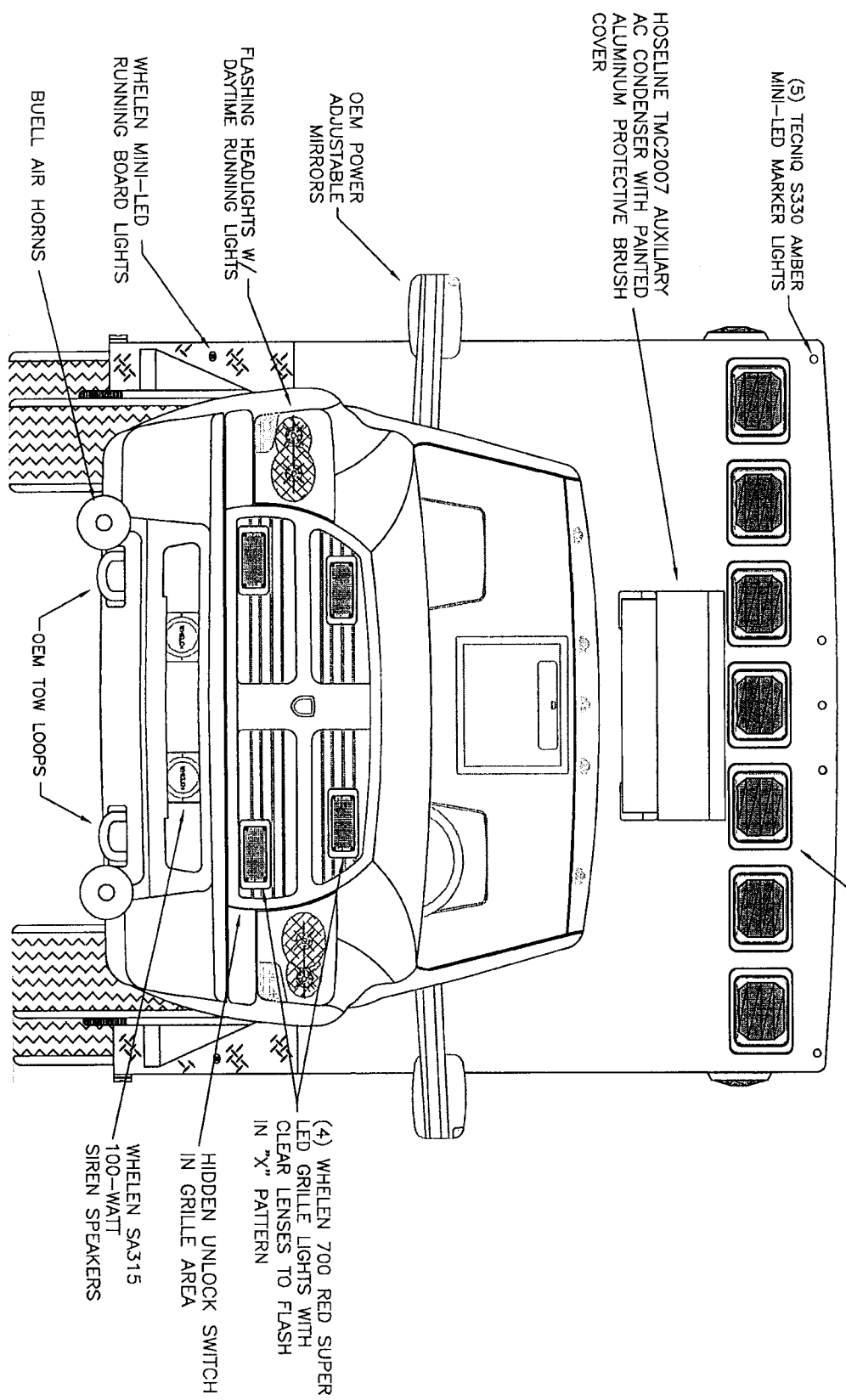

THIS DRAWING IS FOR REPRESENTATIONAL PURPOSES ONLY. DETAILS ARE CONCEPTUAL AND ARE SUBJECT TO CHANGE DURING DESIGN AND CONSTRUCTION
 DIMENSIONS ARE APPROXIMATE UNLESS NOTED OTHERWISE TO MEET A SPECIFIC CUSTOMER NEED.

ST. JOHN'S COUNTY



2016 FRONT EXTERIOR VIEW
 CHIEF XL-1/RAM 4500 CHASSIS

DATE	27 AUG 15	DESIGNED BY	ST JOHNS-1
DRAWN	GLF	CHECKED	NR
SCALE	1:17		

DIMENSIONS FOR OVERALL HEIGHT AND LENGTH ARE APPROXIMATE
 OVERALL HEIGHT = 110"
 OVERALL WIDTH WITH RUB
 RAILS & FENDERLETTS = 98"

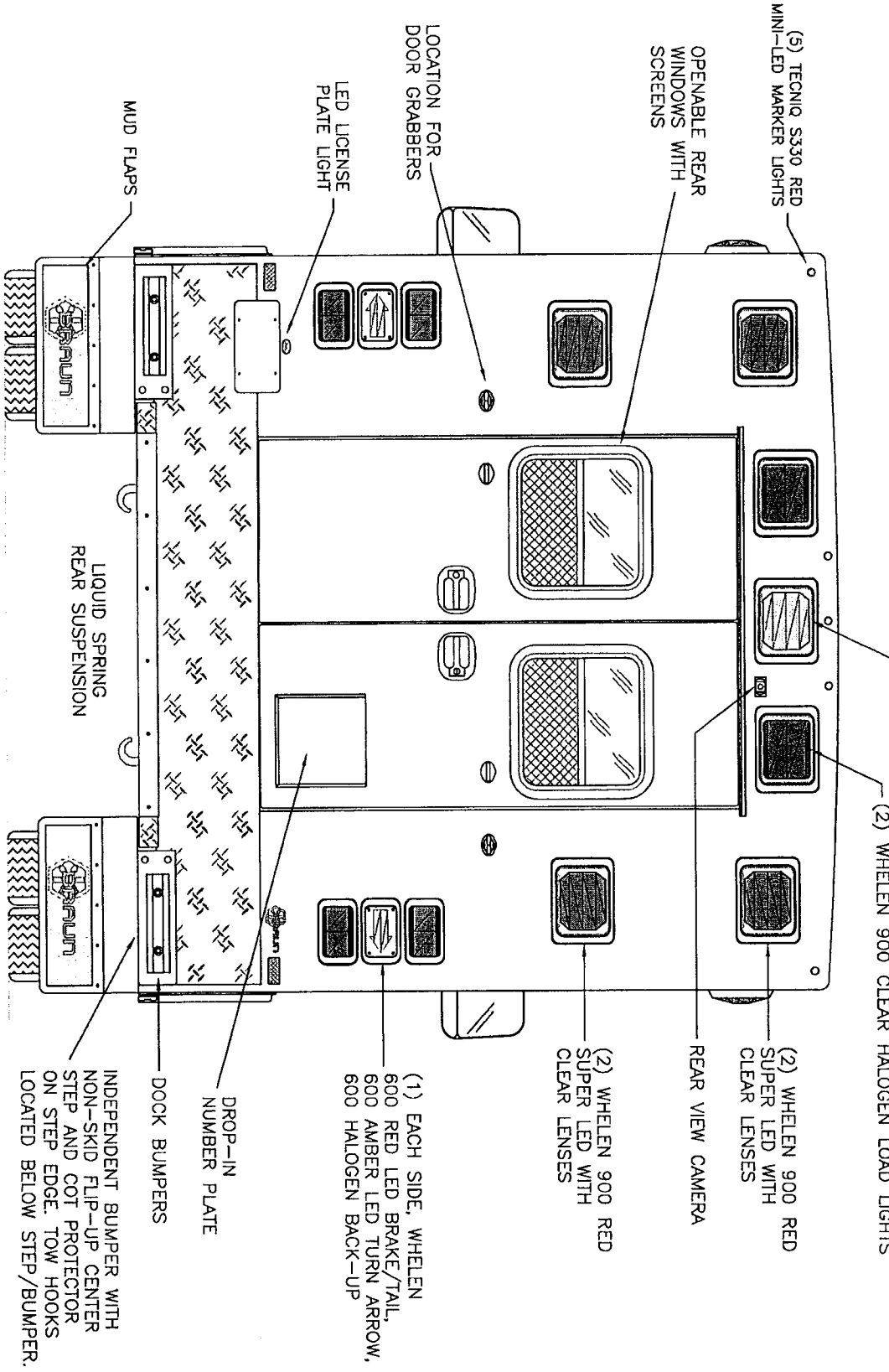

THIS DRAWING IS FOR REPRESENTATIONAL PURPOSES ONLY. DETAILS ARE CONCEPTUAL AND ARE SUBJECT TO CHANGE DURING DESIGN AND CONSTRUCTION
 DIMENSIONS ARE APPROXIMATE UNLESS NOTED OTHERWISE TO MEET A SPECIFIC CUSTOMER NEED.

ST. JOHN'S COUNTY

 VAN WERT, OHIO
 2016 REAR EXTERIOR VIEW
 CHIEF XL-1/RAM 4500 CHASSIS
 1:16
 DATE: 27 AUG 15
 DRAWN BY: GLF NR
 PROJECT NO.: ST JOHNS-2

DIMENSIONS FOR OVERALL HEIGHT AND LENGTH ARE APPROXIMATE
 OVERALL HEIGHT = 110"
 OVERALL LENGTH = 306.5"
 MODULE LENGTH = 189"

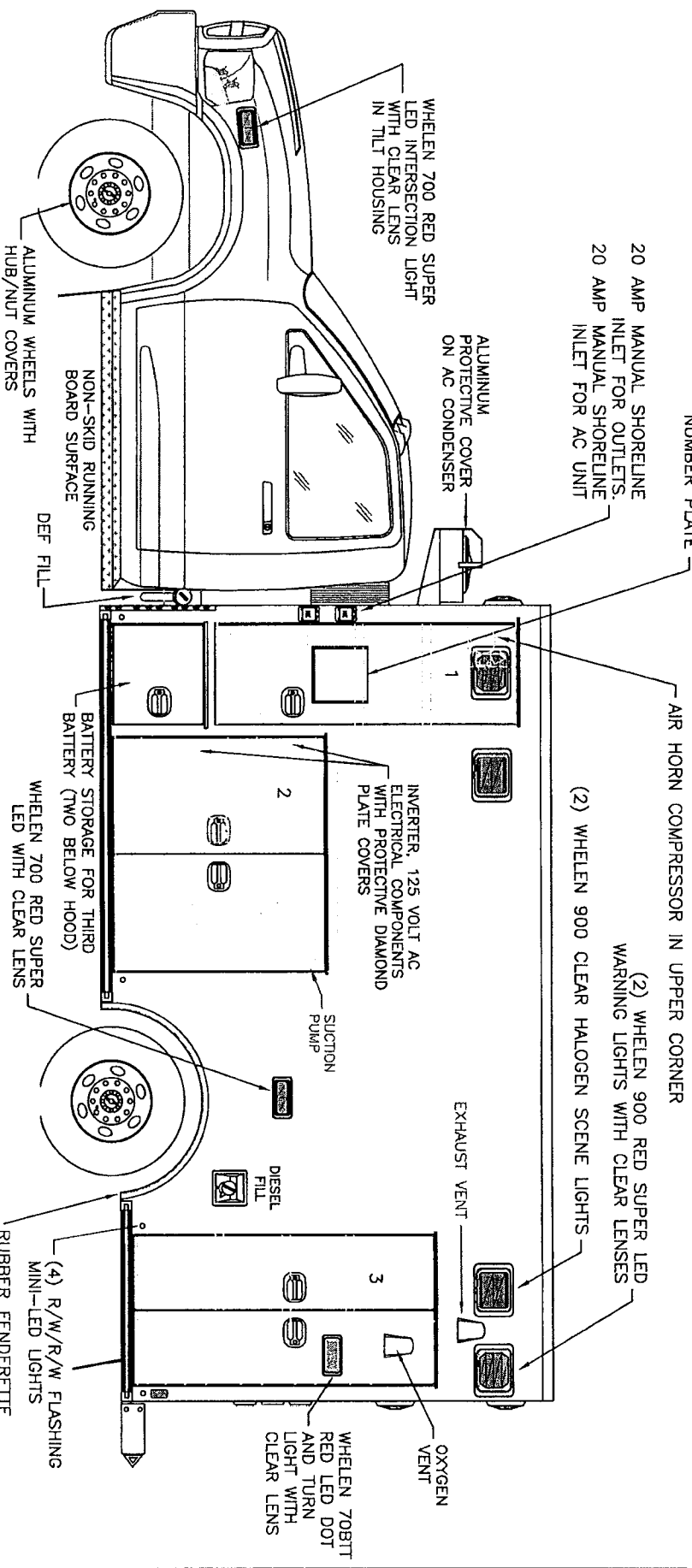

COMPARTMENT
 O.S.S. #1
 CLEAR OPENING: 63.75h x 18.25w
 INSIDE DIM'S: 64.75h x 22.25w x 20.75d
 17.5" WIDE x 19" TALL TRANSVERSE BACKBOARD STORAGE WITH (1) CENTER VERTICAL DIVIDER
 BACKBOARD OPENING TO HAVE NYLON STRAP (2) ADJUSTABLE SHELVES ABOVE BACKBOARDS

O.S.S. #2
 CLEAR OPENING: 44.25h x 45.75w
 INSIDE DIM'S: 47.75h x 49.75w x 20.75d
 (2) SCBA BRACKETS ON REINFORCED BACK WALL OF COMPARTMENT

O.S.S. #3
 CLEAR OPENING: 63.50h x 28.25w
 INSIDE DIM'S: 65.25h x 32.50w x 20.75d
 DUAL "M" TANKS ON SLIDE-OUT BOARD WITH ZICO OR-MV BRACKETS
 VERTICAL DIVIDER NEXT TO OXYGEN SLIDE-OUT STORAGE FOR (2) "D" OXYGEN BOTTLES BELOW SLIDE-OUT OXYGEN

THIS DRAWING IS FOR REPRESENTATIONAL PURPOSES ONLY. DETAILS ARE CONCEPTUAL AND ARE SUBJECT TO CHANGE DURING DESIGN AND CONSTRUCTION
 DIMENSIONS ARE APPROXIMATE UNLESS NOTED OTHERWISE TO MEET A SPECIFIC CUSTOMER NEED.

ST. JOHN'S COUNTY



2016 STREETSIDE EXTERIOR VIEW
 CHIEF XL-1/RAM 4500 CHASSIS

DATE	28 AUG 15	BY	GLF	NO.	NR	PROJECT	ST JOHNS-3
TIME	1:30						

DIMENSIONS FOR OVERALL HEIGHT AND LENGTH ARE APPROXIMATE
 OVERALL HEIGHT = 110"
 OVERALL LENGTH = 306.5"
 MODULE LENGTH = 169"

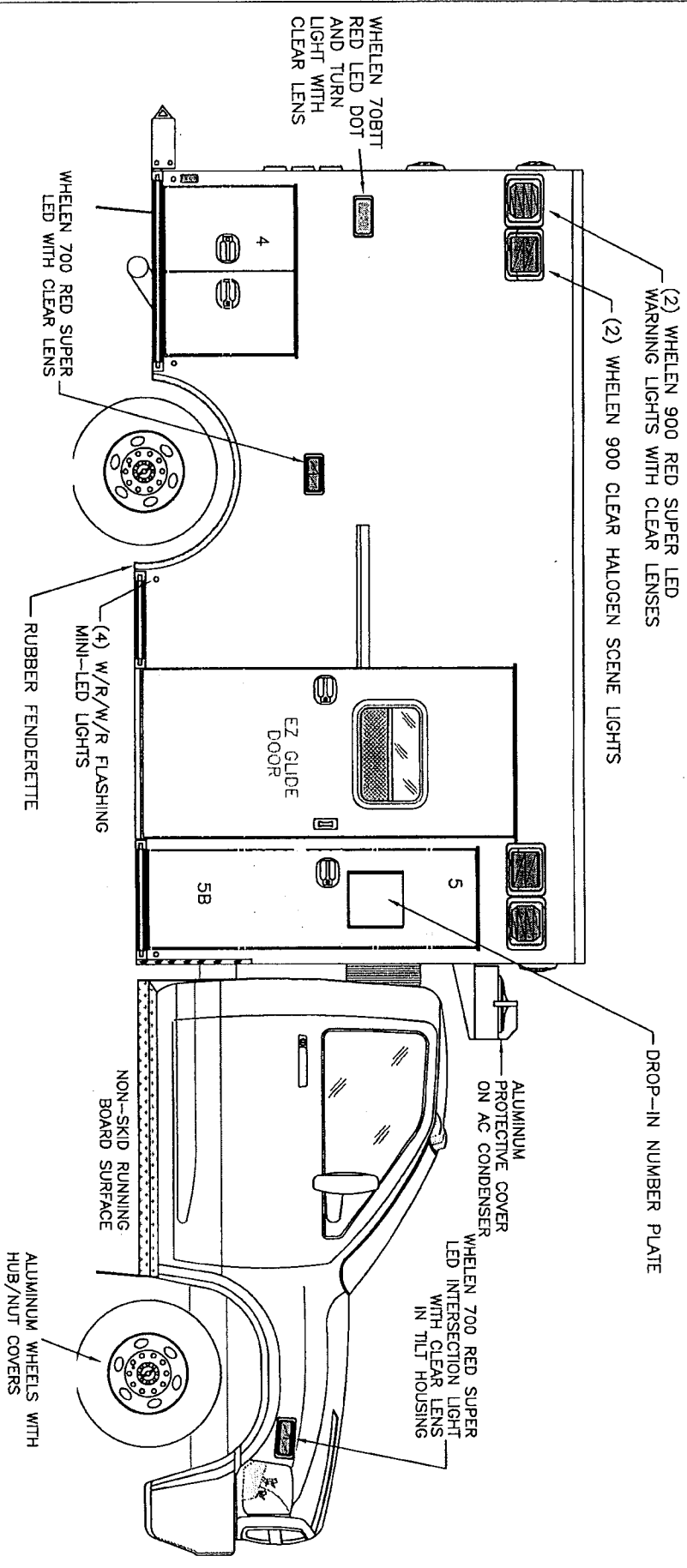

COMPARTMENT
 O.S.S. #4
 CLEAR OPENING: 26.75h x 32.25w
 INSIDE DIM'S: 28.50h x 36.00w x 20.75d
 (1) ADJUSTABLE SHELF

O.S.S. #5
 CLEAR OPENING: 69.50h x 17.50w
 INSIDE DIM'S. 5A: SEE PARTITION INTERIOR VIEW
 INSIDE/OUTSIDE ACCESS WITH (2) ADJUSTABLE SHELVES
 17.5" WIDE TRANSVERSE BACKBOARD ACCESS WITH CENTER DIVIDER
 BACKBOARD OPENING TO HAVE NYLON STRAP
 INSIDE DIM'S. 5B: 19.00h x 20.25w x 18.00d

THIS DRAWING IS FOR REPRESENTATIONAL PURPOSES ONLY. DETAILS ARE CONCEPTUAL AND ARE SUBJECT TO CHANGE DURING DESIGN AND CONSTRUCTION
 DIMENSIONS ARE APPROXIMATE UNLESS NOTED OTHERWISE TO MEET A SPECIFIC CUSTOMER NEED.

ST. JOHN'S COUNTY



2016 CURBSIDE EXTERIOR VIEW
 CHIEF XL-1/RAM 4500 CHASSIS

DATE: 27 AUG 15
 DESIGNED BY: GLF
 CHECKED BY: NR

ST JOHN'S-4

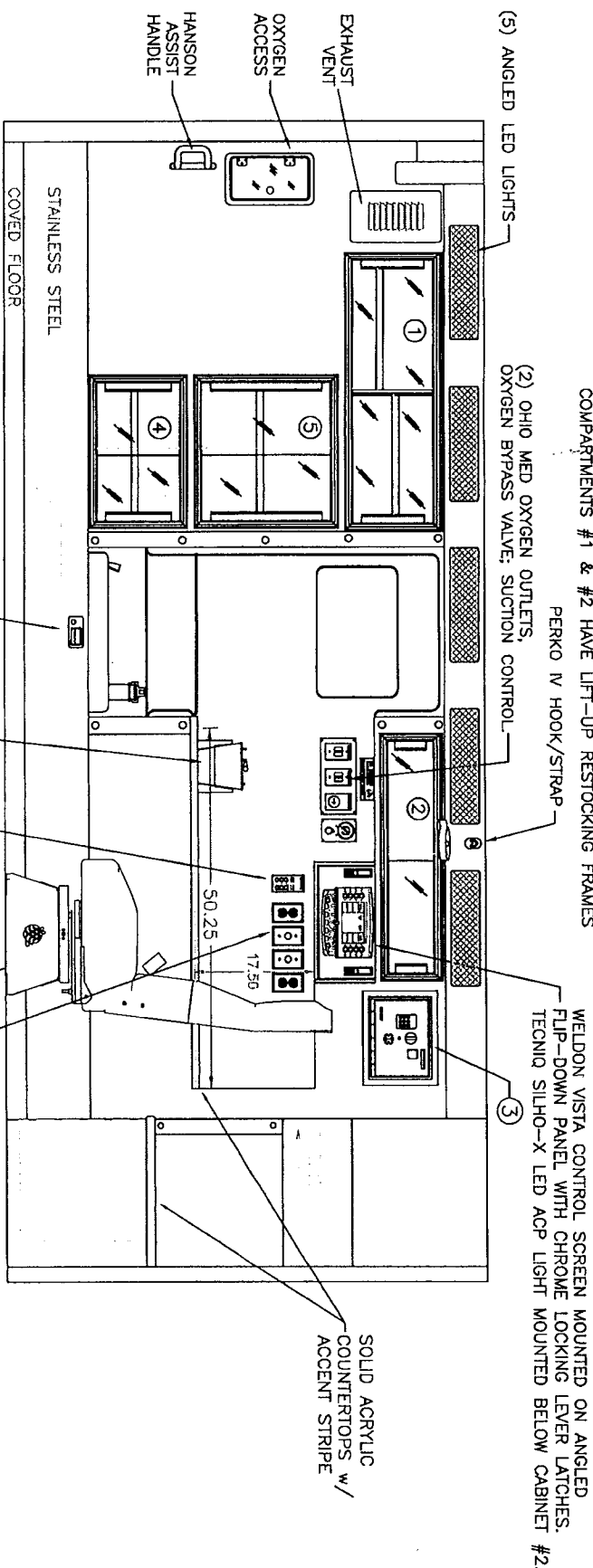

COMPARTMENTS #1 & #2 HAVE LIFT-UP RESTOCKING FRAMES

WELDON VISTA CONTROL SCREEN MOUNTED ON ANGLED FLIP-DOWN PANEL WITH CHROME LOCKING LEVER LATCHES. TECHNIO SILHO-X LED ACP LIGHT MOUNTED BELOW CABINET #2.

(2) OHIO MED OXYGEN OUTLETS, OXYGEN BYPASS VALVE, SUCTION CONTROL.

PERKO IV HOOK/STRAP

(3)

SOLID ACRYLIC COUNTERTOPS w/ ACCENT STRIPE

17.50

50.25

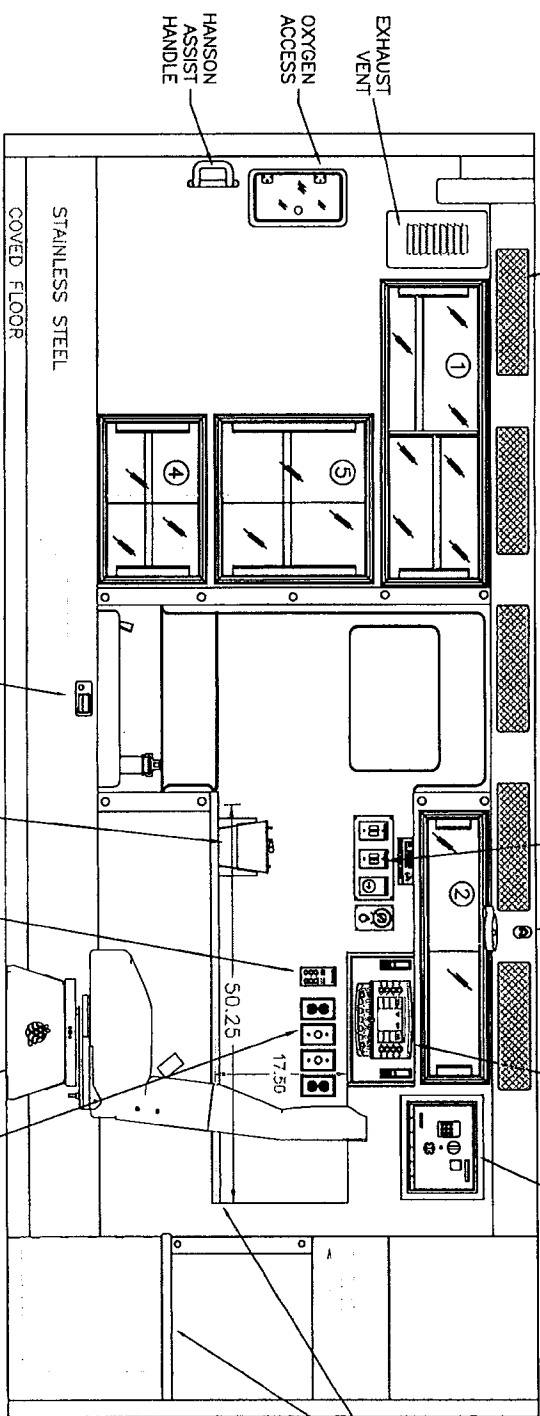

(2) 125 VAC OUTLET,
(2) 12 VDC BATTERY HOT OUTLET
EVS SEAT WITH INTEGRAL CHILD SAFETY SEAT AND ADULT 2-POINT LAP BELT, MOUNTED ON SWIVEL BASE

HOSELINE CM3000 CLIMATE CONTROL

SSCOR SUCTION

UNDERSEAT STORAGE

STAINLESS STEEL

COVED FLOOR

COMPARTMENT

- #1 DOOR OPENING: 11.75h x 38.00w
INSIDE DIMS: 14.25h x 40.00w x 17.25d
FIXED CENTER DIVIDER
(1) ADJUSTABLE SHELF EACH SIDE OF DIVIDER
- #2 DOOR OPENING: 6.75h x 33.25w
INSIDE DIMS: 9.25h x 35.25w x 17.25d
- #3 = FLUSH-MOUNTED KNOX MEDVAULT
- #4 DOOR OPENING: 12.50h x 20.25w
INSIDE DIMS: 14.25h x 22.00w x 16.25d
(1) ADJUSTABLE SHELF
- #5 DOOR OPENING: 18.75h x 20.25w
INSIDE DIMS: 20.50h x 22.00w x 16.25d
(1) ADJUSTABLE SHELF

CABINETS TO BE ALUMINUM

THIS DRAWING IS FOR REPRESENTATIONAL PURPOSES ONLY. DETAILS ARE CONCEPTUAL AND ARE SUBJECT TO CHANGE DURING DESIGN AND CONSTRUCTION DIMENSIONS ARE APPROXIMATE UNLESS NOTED OTHERWISE TO MEET A SPECIFIC CUSTOMER NEED.

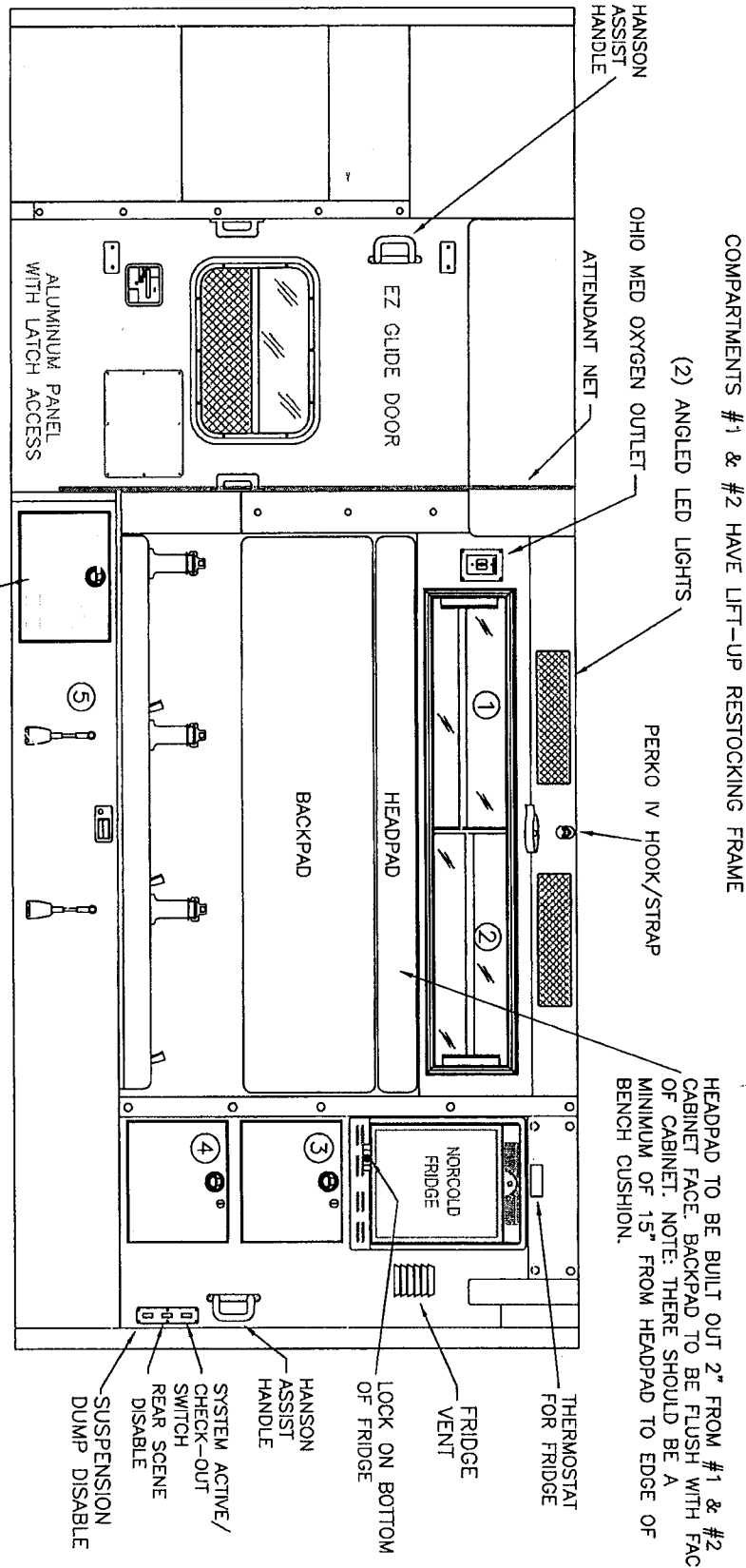

COMPARTMENTS #1 & #2 HAVE LIFT-UP RESTOCKING FRAME

(2) ANGLED LED LIGHTS

HEADPAD TO BE BUILT OUT 2" FROM #1 & #2 CABINET FACE. BACKPAD TO BE FLUSH WITH FACE OF CABINET. NOTE: THERE SHOULD BE A MINIMUM OF 15" FROM HEADPAD TO EDGE OF BENCH CUSHION.

COMPARTMENT
 #1-#2 DOOR OPENING: 9.25h x 59.25w
 INSIDE DIMS: 11.75h x 61.25w x 5.00d
 PERMANENT DIVIDER (CENTERED)
 (1) ADJUSTABLE SHELF ON EACH SIDE OF DIVIDER

#3-#4 PULL-OUT DRUG STORAGE DRAWERS
 INSIDE DIMS: 12.00h x 14.00w x 14.00d
 (1) SOUTHC0 STAINLESS STEEL FLUSH PULL LOCKING LATCH PER DRAWER
 (1) KY-70 CYLINDER LOCK PER DRAWER
 LOCKING SLIDES FOR OPEN POSITION

#5 = MISC. STORAGE BELOW BENCH CUSHION

THIS DRAWING IS FOR REPRESENTATIONAL PURPOSES ONLY. DETAILS ARE CONCEPTUAL AND ARE SUBJECT TO CHANGE DURING DESIGN AND CONSTRUCTION
 DIMENSIONS ARE APPROXIMATE UNLESS NOTED OTHERWISE TO MEET A SPECIFIC CUSTOMER NEED.

CABINETS TO BE ALUMINUM

ST. JOHN'S COUNTY



2016 CURBSIDE INTERIOR VIEW
 CHIEF XL-1

DATE	28 AUG 15	SCALE	1:20
BY	GLF	CHECKED	NR
PROJECT			ST JOHNS-6

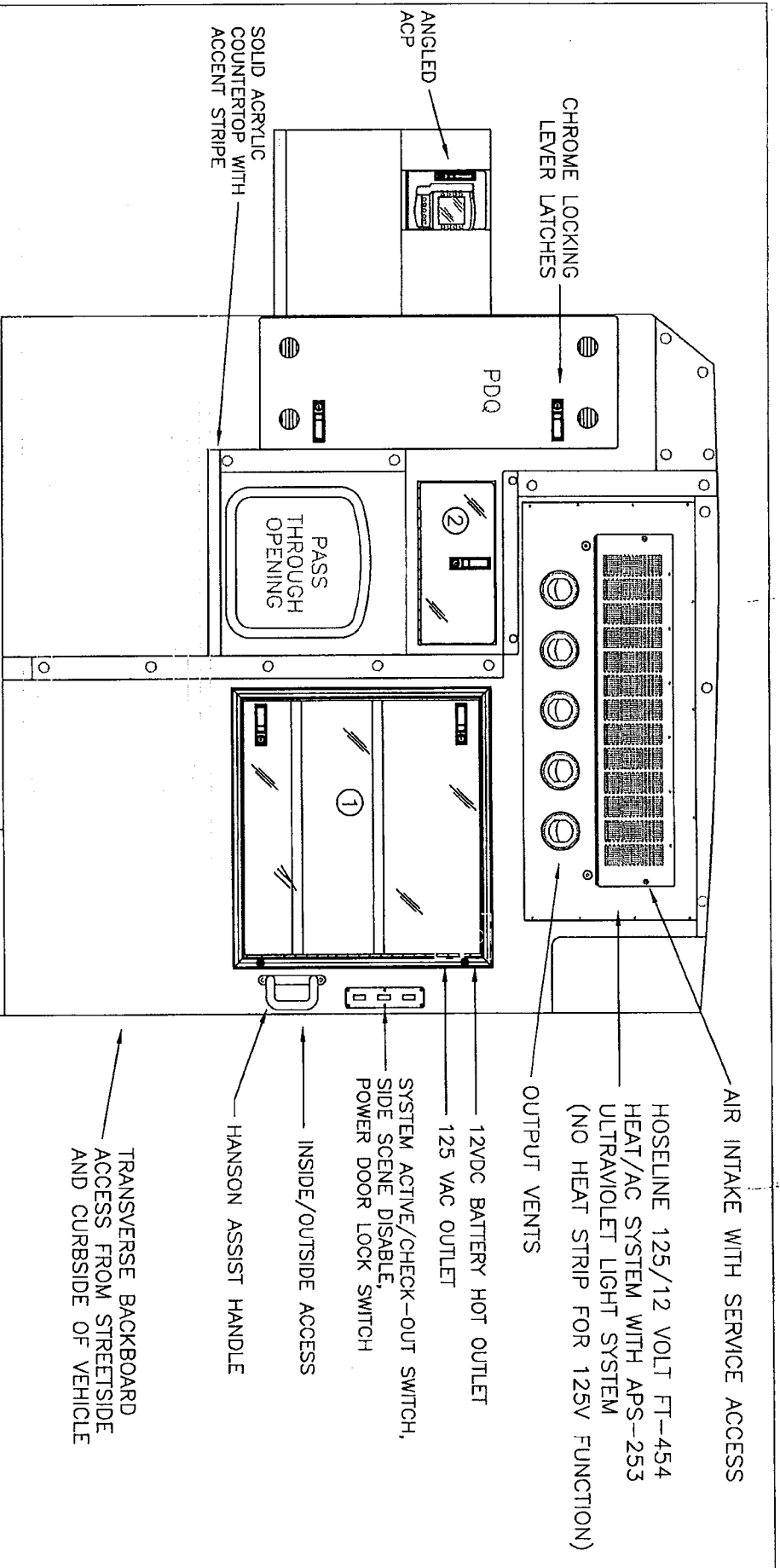

COMPARTMENT
 #1 DOOR OPENING: 24.00h x 25.50w
 INSIDE DIMS: 28.75h x 31.50w x 21.50d
 RECESSED RIGHT-HINGED 1/2" LEXAN DOOR
 (2) CHROME LOCKING LEVER LATCHES
 (2) ADJUSTABLE SHELVES
 DOOR TO HAVE (2) RUBBER BUMPERS ON HINGE
 SIDE SO CABINET DOOR DOESN'T HIT ENTRY DOOR
 (REFERENCE PREVIOUS UNITS #6715/#6716)

#2 DOOR OPENING: 6.25h x 16.25w
 INSIDE DIMS: 7.75h x 18.00w x 20.00d
 DROP-DOWN ACRYLIC DOOR
 CHROME LOCKING LEVER LATCHES

THIS DRAWING IS FOR REPRESENTATIONAL PURPOSES ONLY. DETAILS ARE CONCEPTUAL AND ARE SUBJECT TO CHANGE DURING DESIGN AND CONSTRUCTION. DIMENSIONS ARE APPROXIMATE UNLESS NOTED OTHERWISE TO MEET A SPECIFIC CUSTOMER NEED.

CABINETS TO BE ALUMINUM

ST. JOHN'S COUNTY



2016 PARTITION INTERIOR VIEW
 CHIEF XL-1

DATE	28 AUG 15
BY	GLF
CHKD BY	NR

ST JOHN'S-7

THIS DRAWING IS FOR REPRESENTATIONAL PURPOSES ONLY. DETAILS ARE CONCEPTUAL AND ARE SUBJECT TO CHANGE DURING DESIGN AND CONSTRUCTION. DIMENSIONS ARE APPROXIMATE UNLESS NOTED OTHERWISE TO MEET A SPECIFIC CUSTOMER NEED.

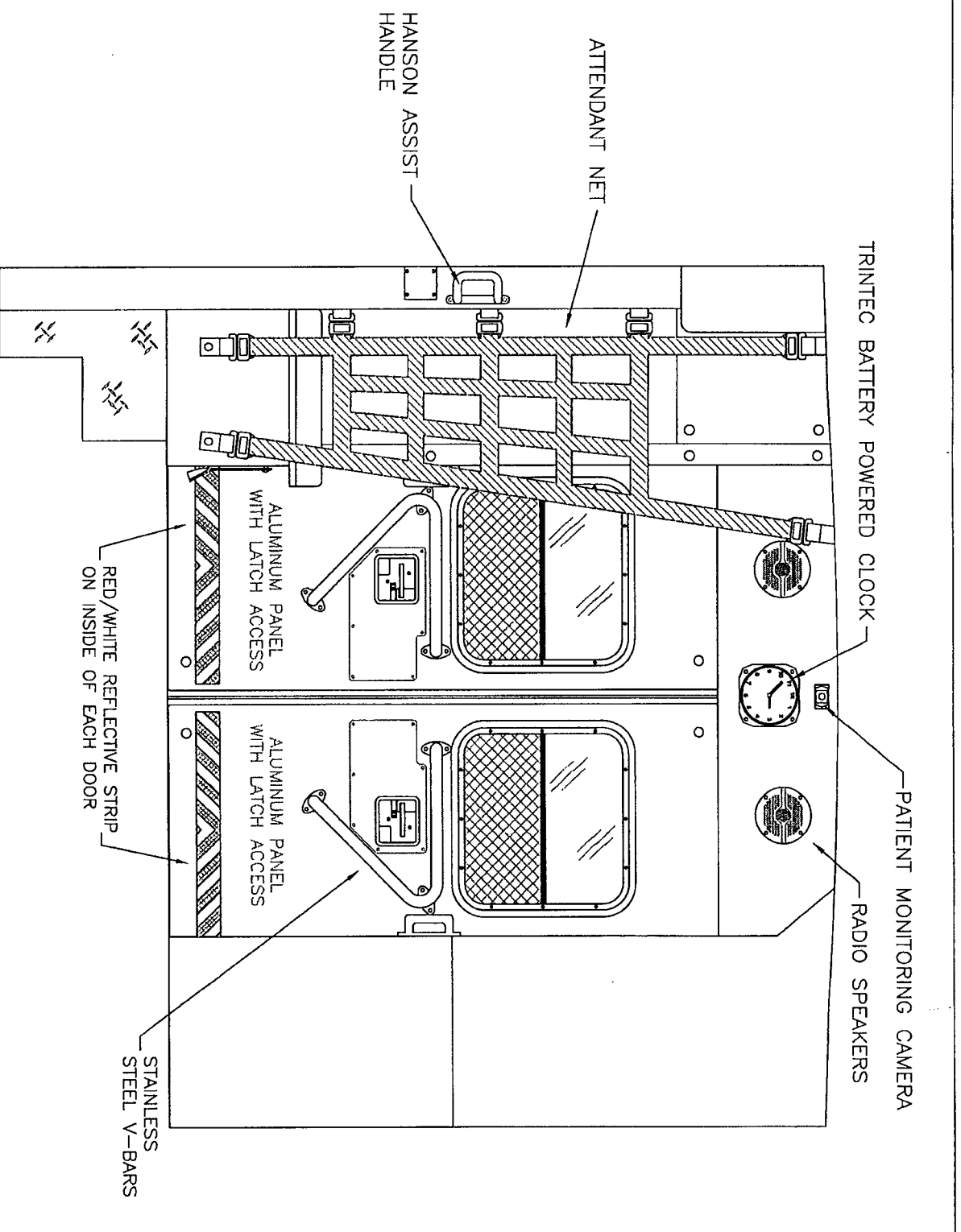

ST. JOHN'S COUNTY



2016 REAR INTERIOR VIEW
CHIEF XL-1

1:12

DATE: 28 AUG 15
BY: GLF/NR

PROJECT: ST JOHNS-8

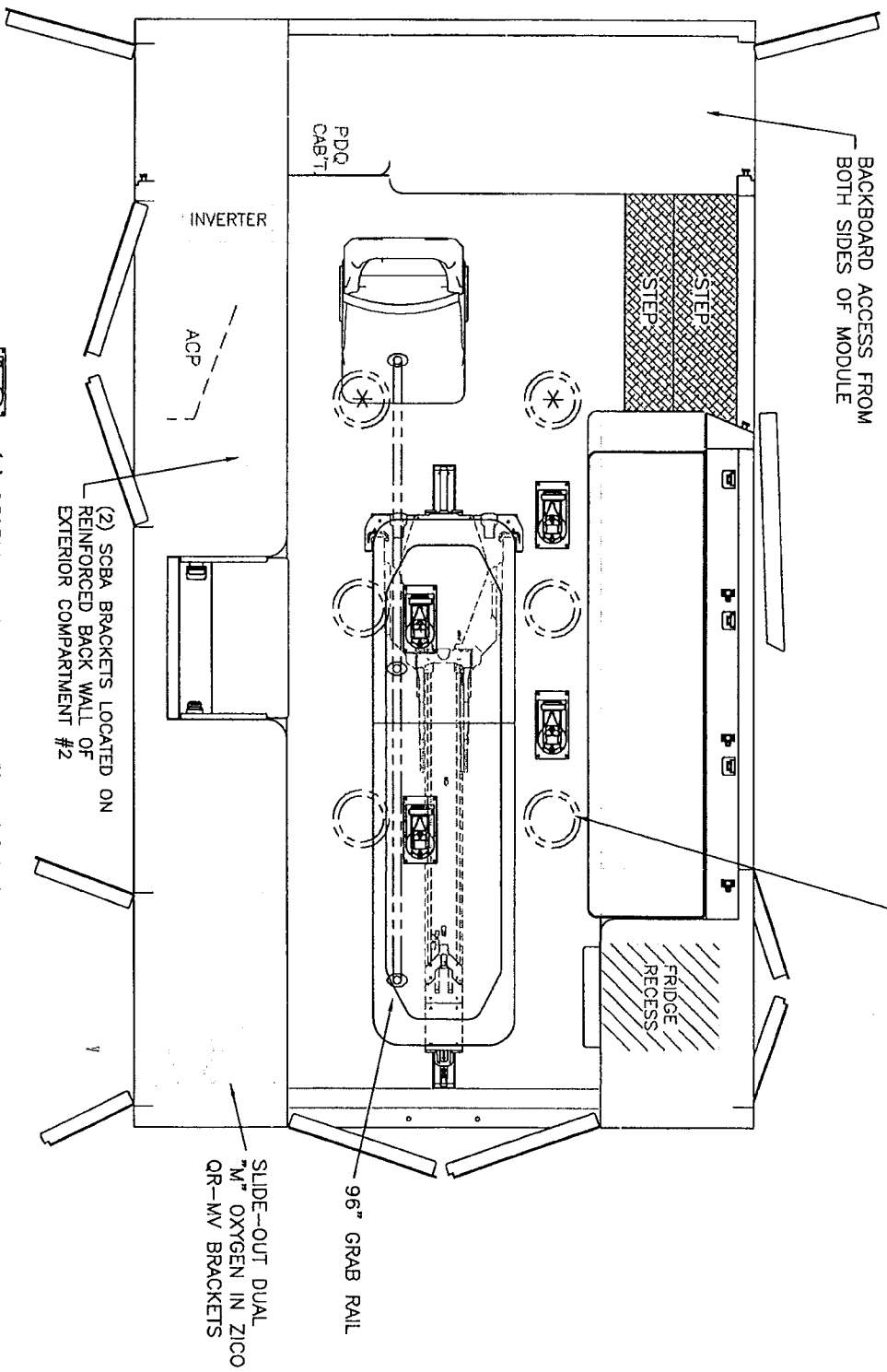

BACKBOARD ACCESS FROM BOTH SIDES OF MODULE

(6) WHELEN LED DOME LIGHTS

FRIDGE RECESS

96" GRAB RAIL

SLIDE-OUT DUAL "M" OXYGEN IN ZICO QR-1W BRACKETS

(2) SCBA BRACKETS LOCATED ON REINFORCED BACK WALL OF EXTERIOR COMPARTMENT #2

[Symbol] = (4) RECESSED CEILING TV HANGER LOCATIONS

* = (2) ANTENNA BASES LOCATED OUTBOARD OF DOME LIGHTS WITH COAX SERVICE LOOP
 STRYKER POWERLOAD COT SYSTEM IN CENTER POSITION

THIS DRAWING IS FOR REPRESENTATIONAL PURPOSES ONLY. DETAILS ARE CONCEPTUAL AND ARE SUBJECT TO CHANGE DURING DESIGN AND CONSTRUCTION. DIMENSIONS ARE APPROXIMATE UNLESS NOTED OTHERWISE TO MEET A SPECIFIC CUSTOMER NEED.

ST. JOHN'S COUNTY



2016 FLOOR INTERIOR VIEW

CHIEF XL-1

1:22

DATE	28 AUG 15	PROJECT	ST JOHNS-9
DRAWN	GLF	NR	

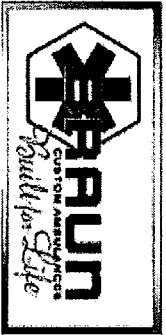

Shop Order

Ten-8 Fire Equipment

Exp. Date: 10/14/2015
 Quote No: 10009-0002
 AMB I: 16CHXL I

Chief XL 2016 Type I / 169" Module

11/03/2015

Printed by: travisp

Page 1

FUNCTION 1	PART NO	S	QTY	DESCRIPTION
	00-01-0026	X	1	Chief XL 2016 Type I / 169" Module - 16,000 05/07/15 FSA CONTRACT <i>Braun discount</i> This order does specify an FSA contract
	00-01-0051		1	NO REQUIRED DELIVERY DATE No Specific Required by Delivery Date
	00-01-0091		1	REQUIRED REMAINING EQUIPMENT PAYLOAD: The required remaining equipment payload for this unit is: _____
	00-01-0244		1	TYPE I - AMBULANCE - CHIEF XL I - 72" INTERIOR HEADROOM 2016 CHIEF XL I - 169" MODULE
	10-04-0031		1	CHASSIS - RAM 4500 192" WB 4x2 2016
	10-08-0000		1	** NO CUSTOM CHASSIS REQUIRED ** NO SPECIAL CHASSIS QUOTED
	20-10-0103		1	SUSPENSION - LIQUID SPRING Liquid Spring IPOS Kelderman
	20-10-0112		1	INBOARD ARM RESTS Install inboard arm rests in the cab. (arm rests Havis Shields C-ARM-102 mount to floor console) Reference truck 5875
	20-10-0209	X	1	BATTERY - THREE SYSTEM - D SERIES CHASSIS Install an additional battery to make a total of three (3). Third battery is to be isolated and wired for the

FUNCTION 1	PART NO	S	QTY	DESCRIPTION
	20-20-0126	X	1	FLOOR CONSOLE - ANGLED FRONT - REMOVABLE PLATES - ALUMINUM-MODIFIED NO MAP A center floor console manufactured out of aluminum and covered in a black onyx zolstone. The console shall include a raised area for the Weldon Vista display on a hinged adjustable mount. The lower portion of the console shall consist of a flat area that shall contain the siren, two (2) drink holders. The map storage area is to be deleted and the removable plate is to run all the way to the rear of the console. The console face plates shall be removable for accessibility and serviceability.
	20-20-0126		1	FLOOR CONSOLE - ANGLED FRONT - REMOVABLE PLATES - ALUMINUM A center floor console manufactured out of aluminum and covered in a black onyx scratch resistant, multi-use polychromatic coating with a clear epoxy finish shall be installed in the cab. The console shall include a raised area for the Weldon Vista display on a hinged adjustable mount. The lower portion of the console shall consist of a flat area that shall contain the siren, two (2) drink holders, and then to the rear center a recessed storage area for maps and reports. The console face plates shall be removable for accessibility and serviceability.
	20-20-0241		1	CHASSIS HEADLINER SUPPORT Verify that there is foam located between the chassis headliner and roof to minimize cab roof flex. If needed install the Ram approved foam per work instructions.
	20-40-0208		1	OEM WHEELS - WITH VALVE STEM EXTENSIONS Delete the Stainless Steel Wheel liners, Keep Valve Extensions and OEM wheels.
	20-SP-0001	X	1	ALUMINUM WHEELS W/HUB & NUT COVERS Chassis is to be ordered with Aluminum rims.
	30-10-0012	X	1	ELECTRICAL SYSTEM FEATURES AIR HORNS - BUELL DUAL TRUMPETS 10" & 12", UNDR BMPR W/SW Air Horn - (Buell) dual trumpets, one (1) 10" and one (1) 12", mounted under front bumper, one each side, compressor w/cover in OSS #1 located per dwg. #3. The air horns shall be activated by a push button switch located on the MCC (master control console); See Dwg #1
	30-10-0071		1	CAMERA REAR VIEW - SINGLE SYSTEM - VISTA SCREEN Install camera system rear view, tied to M-Tech display screen. Per Dwg #2
	30-10-0073	X	1	Camera Single system
	30-10-0262	X	1	Vanner inverter - 1050W #20-1050 CUL
	30-10-0291		1	LIGHT, ATTENDANT CONTROL PANEL AREA - LED - WARM WHITE A Techniq Silho-X 2.75" round warm white LED light with SS trim ring, shall be mounted above the left wall forward action area counter. The light shall be operated through the a button on the ACP Vista screen labeled "Attendant Light". (Braun #26415)
	30-10-0431	X	2	LIGHT, STEPWELL - CURBSIDE DOORWAY - 2" LED SURFACE MNT Two (2) Lights, stepwell - side doorway, Whelen 2" LED (#18105 with surface mount flange #27190). See

FUNCTION 1		PART NO	S	QTY	DESCRIPTION
					Dwg #7
		30-10-0476	X	1	LIGHTS, DOME LED (6) Whelen Six (6) Whelen #LED (80CCEHCR) dome lights, shall be installed IPOS. See dwg #9
		30-10-0486	X	1	Lights recessed LED Panel (5) Streetside
		30-10-0490	X	1	Lights recessed LED pane (2) curbside
		30-10-0527		1	OUTLETS, 125VAC - THREE (3) INTERIOR DUPLEX One (1) outlet located in forward action area per dwg #5 One (1) outlet located in rear action area per dwg #5 One (1) outlet located in lower front wall cabinet per dwg #7
		30-10-0534	X	1	OUTLETS, 125VAC - FOUR (4) INTERIOR DUPLEX Two (2) shall be installed in the primary action area. Located per dwg. #5. One (1) shall be installed in the lower front wall cabinet #1. Located per dwg. #7. One (1) shall be installed in the cab console. It is to be located on the side of the console on the passenger side.
		30-10-0560	X	1	OUTLETS, 12VDC - THREE (3) INTERIOR POWERPOINT Two (2) shall be installed in the primary action area. Located per dwg. #5. One (1) shall be installed in the lower front wall cabinet #1. Located per dwg. #7. All 12V outlets are to be battery hot.
		30-10-0657		1	RADIO ANTENNA BASES - TWO (2) Two (2) antenna bases with attached coax cables shall be installed on the module roof. The coax cables shall terminate in the PDQ. Access to the antenna bases shall be through adjacent module interior dome lights.
		30-10-0657	X	1	RADIO ANTENNA BASES - TWO (2) Both antenna bases are to terminate to the PDQ.
		30-10-0721		1	RECEPTACLE SHORELINE INLET-20 AMP, NON-AUTO EJECT Install 20 amp manual (non-auto eject) shoreline receptacle. IPOS
		30-10-0738	X	1	REFRIGERATOR - NORCOLD 1.7 CU FT BUILT-IN Install an aisle facing, Nor-Cold refrigerator in upper cabinet at rearward end of squad bench IATS, per dwg. # 6. Install Medico lock on aluminum plate to secure. Install thermometer on fridge, surface mount and drill hole and run wire inside for probe. Thermometer to be Grainger 2LYX2Millioco CD104684-60W Thermometer) to be installed per dwg. #6 location.
		30-10-0814		1	SIREN SPEAKERS, WHELEN SA315 - IN THE BUMPER OPENING Whelen dual 100 watt siren speakers shall be installed in the bumper opening.
		30-11-0101		1	LIGHTS, DOME LED (8) Techniq Eight (8) Techniq LED (E08-LC10-1) dome lights, shall be installed. Per dwg #9

FUNCTION 1	PART NO	S	QTY	DESCRIPTION
	30-11-0152		1	LIGHTS, TECNIO LED PANEL (3) STREETSIDE - ANGLED Three (3) Tecnio (E30-L010-1) 21 LED lights streetside (Braun #27469). See Dwg #5
	30-11-0176		1	LIGHTS, TECNIO LED PANEL (2) CURBSIDE - ANGLED Two (2) Tecnio (E30-L010-1) 21 LED lights curb side (Braun #27469). See Dwg #5
	30-25-0102	X	1	LIGHTS, WHELEN 70BTT RED DOT TURN /POS ICC The vehicle shall have two (2) red LED Whelen 70BTT in place of the clearance / ICC lights with chrome bezels : one (1) red on each side at the rear of the vehicle which will also function with the turn signals. Per Dwg #3 and #4
	30-25-0122		1	LIGHTS, ICC / LED CLEARANCE - ON MODULE FRONT - TECNIO The vehicle shall have five (5) amber Tecnio LED (S33-AA00-1) clearance / ICC lights on the front of the module near the roof line. Per Dwg #1
	30-25-0123		1	LIGHTS, ICC / LED CLEARANCE - ON MODULE REAR - TECNIO The vehicle shall have five (5) red Tecnio LED (S33-RR00-1) clearance / ICC lights on the rear of the module near the roof line. Per Dwg #2
	30-25-0201	X	1	Lights running board Whelen mini
	30-25-3111		1	LIGHTS, FRONT GRILLE - (2) WHELEN 700 SUPER LED - RED W/CLEAR LENS Whelen 700 series red super LED lights w/clear lens
	30-25-3114	X	1	Lights, Front grille- 4 Whelen 700 series
	30-25-4201		1	LIGHTS, FRONT MODULE - WHELEN (7)900 - (6)RED, (1)CLEAR LED W/CLEAR LENS Seven (7) Whelen 900 series super LED lights with chrome flanges shall be installed on the module front. There shall be six (6) red and one (1) center clear light. All lights to have clear lens IPOS
	30-26-3002		1	LIGHTS, REAR TAIL - WHELEN 600 LED STOP, TURN, HALOGEN BK-UP One (1) pair each of Whelen 600 series led stop/tail lights, turn lights, and halogen back-up lights with chrome bezels shall be installed on the rear of the module. (meets SAE)
	30-26-5101		1	LIGHTS, REAR WINDOW-LEVEL - WHELEN (2)900 LED - RED W/CLR LENS Two (2) Whelen 900 series red super LED lights w/clear lenses and chrome flanges shall be installed on the rear of the module at window level, one (1) on each side. Per dwg #2
	30-26-6101	X	1	LIGHTS, REAR MODULE -WHELEN (2)900 RED, (1)900 AMB LED, (2)900 HALO SCN CLR LEN Two (2) Whelen 900 series red super LED lights w/clear lens, two (2) Whelen 900 series halogen sceneload lights, and one (1) Whelen 900 series amber super LED light w/clear lens shall be installed on the rear of the module w/chrome flanges. See dwg #2
	30-26-6168		1	LIGHTS, REAR MODULE -WHELEN (5)900, (2)RED, (1)AMB LED, (2)HALO SCN CLR L Two (2) Whelen 900 series red super LED lights w/clear lens, two (2) Whelen 900 series halogen sceneload lights, and one (1) Whelen 900 series amber super LED light w/clear lens shall be installed on

FUNCTION 1		PART NO		S	QTY	DESCRIPTION
						the rear of the module w/chrome flanges JPOS. See dwg #2
		30-27-1102		1		LIGHTS, ICC / LED CLEARANCE - ON MODULE SIDE - TECHNIQ The vehicle shall have two (2) red Techniq LED (S33-RR00-1) clearance / ICC lights : one (1) red on each side at the rear of the vehicle which will also function with the turn signals. Per Dwg #3 and #4
		30-27-1114		1		LIGHTS, INTERSECTION FRONT - WHELEN 700 SUPER LED - RED W/CLR LENS Two (2) Whelen 700 series red super LED warning lights, with clear lens and water-proof connectors shall be mounted, in 15 degree tilt housings on the front chassis fenders, one (1) on each side.
		30-27-2007		1		LIGHTS, SIDE MODULE SCENE - WHELEN 900 HALOGEN - CLEAR (4) Four (4) Whelen 900 series (gradient optics) halogen scene lights with chrome flanges shall be installed, two (2) each module side, inboard of the warning lights.
		30-27-3009		1		LIGHTS, SIDE MODULE WARNING - WHELEN 900 SUPER LED - RED W/CLR LENS Four (4) Whelen 900 series red super LED warning lights with clear lenses and chrome flanges shall be installed, two (2) each module side, outboard of the side module scene lights. Per dwg #3 & #4
		30-27-4115		1		LIGHTS, INTERSECTION REAR - WHELEN 700 SUPER LED - RED W/CLR LENS Two (2) Whelen 700 series red super LED warning lights with clear lenses, chrome flanges and water-proof connectors, shall be installed above the rear wheel wells, one (1) on each side Per Dwg #3 & #4
		30-27-4151	X	1		Lights, above rub rail, Techniq-4
		40-09-0164	X	1		MODULE FEATURES / EXTERIOR ZICO SCBA HOLDERS TWO (2) Two (2) SCBA mounting brackets installed on reinforced back wall. (Delete the standard adjustable shelf and install two (2) Zico KD-UH-U-6 SCBA mounting brackets for MSA 30 Min bottles with spring release). Per dwg. # 3.
		40-10-0100	X	1		Fenderettes - Black rubber
		40-10-0120		1		HOLD-OPEN - REAR DOORS - GRABBERS Door grabbers (1 pair) with hard rubber inserts shall be installed on the rear doors. Reference dwg #2 for location.
		40-10-0151		1		SWITCH DOOR UNLOCK - HIDDEN IN FRONT GRILLE AREA An exterior hidden door unlock switch shall also be included and located in the front grille area.
		40-10-0189		1		LOCKS POWER - PASSAGE COMPARTMENTS, KEY FOBS Install power door locks on module passage doors, and (5) OSS compartments, use OEM key fobs.
		40-10-0280	X	1		RUB RAILS, ANODIZED ALUMINUM Bright dip anodized polished aluminum rub rails shall be installed on the lower sides of the body below the outside compartment sill areas. The rub rails shall be offset 3/16" from the body to facilitate wash down of road debris. The rub rails shall incorporate a recessed 5/8" wide black reflective scotchlite safety accent

FUNCTION 1	PART NO	S	QTY	DESCRIPTION
	40-10-0300	X	1	Dock bumpers, rear
	40-10-0386	X	1	VEHICLE ID PLACARDS (Total 3) Three (3) vehicle ID placards shall be provided and installed as follows One (1) located forward on the street side of the module. Per dwg. #3 One (1) located forward on the curb side of the module. Per dwg. #4 One (1) located on the rear of the module. Per dwg. #2.
				The placards are to be painted to match the color of the unit and to be 12" x 12" with the unit number decal installed. The number(s) on the placard to be reflective without shadow. Unit numbers to be #18 and #5.
	40-10-0506		1	WINDOWS, PASSAGE DOOR - (CURB SLIDING, REAR SLIDING) Install sliding windows with screens in rear doors IPOS
	40-SP-0001	X	1	BATTERY COMPARTMENT Install a battery compartment below OSS #1 per dwg. #3 dimensions. This will shorten the OSS #1 compartment. 3rd battery will be installed in this compartment. Per dwg. #3.
	41-01-0201	X	1	OUTSIDE STORAGE #1 - STREETSIDE FORWARD-MODIFIED OSS #1 has been modified (height) due to the relocation of the battery compartment. OSS #1 is to be built per dwg. #3 dimensions. Transverse backboard storage to OSS#5 to have (2) sections with one divider (chute dimensions 17.50"w x 19" ID x 74") - Install strap across transverse opening. Install (2) adjustable shelves above chute, allow minimum of 17.75" below chute for storage. Per dwg. #3 layout. Shelf track to stop at the top of the transverse storage area in OSS#1. Per dwg. #3.
	41-02-0101	X	1	** NO ADJUSTABLE SHELVES OSS #1 REQUIRED ** See 41-01-0201 Two adjustable shelves above transverse compartment
	42-01-0201	X	1	OUTSIDE STORAGE #2 - STREETSIDE CENTER Delete the standard adjustable shelf and install two (2) SCBA brackets on reinforced back wall, Zico KD-UH-6-SF per dwg #3 (street side center compartment) shall have a 40.25" high x 45.75" wide clear door opening with double doors and shall have 43.75" high x 50.00" wide x 20.75" deep interior dimension.
	42-02-0053	X	1	DELETE SHELF TRACK - RECESSED - OSS #2 Delete shelf track in OSS#2
	42-02-0054		1	SHELF TRACK - EXPOSED - OSS #2 Install exposed shelf track in OSS #2 (Exposed tracks will be welded in place and coated with Gatorhyde material for a cleaner look and no exposed fasteners)

FUNCTION 1	PART NO	S	QTY	DESCRIPTION
	42-02-0102	X	1	DELETE SHELF ONE (1) IN OSS #2 Delete one (1) adjustable shelf in OSS #2.
	42-02-0107		1	SHELF ONE (1) IN OSS #2 Install one (1) adjustable shelf in OSS #2.
	43-01-0201	X	1	OUTSIDE STORAGE #3 - STREETSIDE REAR - TALL DOOR Dual "M" tanks on a slide out board with Zico QR-MV brackets. Vertical divider next to O2 slide out (3) Adjustable shelves forward of the divider. A fixed shelf 8" above floor below slider for storage for (2) "D" cylinders below slide out oxygen. An oxygen vent on right side of door per dwg #3. The "M" tanks shall be able to be switched enroute from the interior in case runs low. Provide and install two (2) oxygen regulators with "T" to main O2 line so customer can switch between bottles without removing a regulator.
	43-02-0051		1	SHELF TRACK - EXPOSED - OSS #3 Install exposed shelf track in OSS #3. (Exposed tracks will be welded in place and coated with Gatorhyde material for a cleaner look and no exposed fasteners)
	43-02-0104	X	1	Shelves three (3) in OSS#3
	43-02-0108		1	SHELF ONE (1) IN OSS #3 Install one (1) adjustable shelf in OSS #3.
	43-03-0102	X	1	DIVIDER, FIXED - ONE (1) IN OSS #3 Install one (1) fixed divider in OSS #3 to separate the Oxygen bottles from shelves
	43-04-0102	X	1	TRAY (1) SLIDE OUT W/TREMPRO LINING OUTSIDE STORAGE #3 Install one (1) slide-out board to hold (2) "M" oxygen cylinders in OSS #3
	44-01-0011	X	1	PACKAGE - OXYGEN STORAGE OSS #4 DELETE DELETE OSS#4, Oxygen is in OSS#3.
	44-01-0200	X	1	OSS#4 OSS #4 to be full depth constructed and shortened per dwg. dimensions. Compartment enclosed with double doors and equipped with one (1) adjustable shelf IPOS, per dwg. # 4.
	44-01-0201	X	1	OUTSIDE STORAGE #4A BOARD/SCOOP, #4B O2 CYLINDER - RT. REAR DELETE OSS4A
	45-01-0201	X	1	OUTSIDE STORAGE #5 - CURBSIDE FORWARD-MODIFIED OSS#5 shall have a transverse backboard storage to OSS#1 with inside/ outside access to lower front wall cabinet IPOS per dwg. #3, #4 and #7. Install a strap across transverse opening. Maintain the (2) standard adjustable shelves upper portion on the lower front wall cabinet per dwg #7.

FUNCTION 1	PART NO	S	QTY	DESCRIPTION
				MODULE INTERIOR / PATIENT COMPARTMENT FEATURES
	50-01-0407	X	1	LATCHES CABINET - CHROME / STAINLESS STEEL Install chrome locking lever latch on ACP, PDO, and radio cabinet doors. Install Southco stainless steel locking flush pull latches on all other interior drawers and doors.
	50-01-0407	X	1	LATCHES CABINET - CHROME / STAINLESS STEEL Install chrome locking lever latch on ACP, PDO, and radio cabinet doors. Install Southco stainless steel locking flush pull latches on all other interior drawers and doors.
	50-10-0111		1	MY14 standard is 13 pulls and 5 levers, this unit per drawings reflect 3 pulls and 7 levers, adjusted accordingly. CABINET - LEFT WALL, UPPER REAR #1 - FIXED FRAME The cabinet shall contain a center fixed divider with one (1) adjustable shelf on each side.
	50-10-0146	X	1	CABINET - LEFT WALL, UPPER REAR #1 - RESTOCKING HINGE (UP)-MODIFIED Left wall cabinet #1 has been modified (length) due to the deletion of the #1A flip-up cabinet. Cabinet is to have fixed center divider with one (1) adjustable shelf each side of the divider. Cabinet is to be enclosed by a set of sliding acrylic doors that are attached to a flip-up restocking frame. Per dwg. #5.
	50-10-0207	X	1	CABINET - LEFT WALL, UPPER OVER PANEL #2 RESTOCKING HINGE-MODIFIED Left wall cabinet #2 has been modified (length and height) due to the deletion of the #2A cabinet and the installation of the flush mounted Knox Medvault. Cabinet is to be built and installed per dwg. #5 dimensions. Cabinet will not have an adjustable shelf. Cabinet is to be enclosed by a set of sliding acrylic doors that are attached to a flip-up restocking frame. Per dwg. #5.
	50-10-0219		1	CABINET - LEFT WALL, UPPER OVER PANEL #2 - FIXED FRAME The cabinet shall contain a center fixed divider with one (1) adjustable shelf on each side.
	50-10-0229	X	1	LEFT WALL - ATTENDANT CONTROL PANEL - HINGED PANEL-MODIFIED The color micro processor screen shall be installed on an angled hinged access panel and secured with two (2) latches. The panel will be located to the immediate right of the attendant's seat. The forward flat portion of the panel has been deleted. Per dwg. #5.
	50-10-0303	X	1	Cabinet - Left wall upper #3 Install a flanged mounted MEDVAULT IPPOS upper front street-side cabinet. Located per dwg. #5.
	50-10-0342		1	CABINET - LEFT WALL, LOWER REAR #3 - INSIDE/OUTSIDE
	50-10-0401	X	1	Cabinet #4 delete inside / outside access Delete the lower street-side rear inside/outside cabinet, per dwg. #5.
	50-10-0421		1	DRAWERS - LEFT WALL - REAR ACTION AREA (2) DRAWER UNIT #4 A two (2) drawer cabinet unit shall be installed under the second action area on the interior street-side of the module per dwg. #5. The drawers shall open towards the CPR seat and be secured with locking stainless steel flush pull latches.

FUNCTION 1	PART NO	S	QTY	DESCRIPTION
	50-10-0421	X	1	CABINET IN PLACE OF THE DRAWER ASSY- LEFT WALL - REAR ACTION AREA (2) DRAWER Install a cabinet in place of the with one (1) shelf two (2) drawer cabinet unit shall be installed under the second action area on the Interior streetside of the module LATS, per dwg. # 5, cabinet #4. The drawers shall open towards an expanded width CPR seat and be secured with locking stainless steel flush pull latches.
	50-10-0522	X	1	LEFT WALL CABINET #4 Install left wall cabinet #4 per dwg. #5 dimensions and location. This will delete the two (2) drawer unit that opens into the CPR seat. Cabinet is to have one (1) adjustable shelf. Cabinet is to be enclosed by a set of sliding acrylic doors. Per dwg. #5.
	50-10-0634	X	1	DELETE SECONDARY ACTION AREA Secondary action has been deleted. Per dwg. #5.
	50-10-0635	X	1	LEFT WALL CABINET #5 Install left wall cabinet #5 per dwg. #5 location and dimensions. Cabinet is to have one (1) adjustable shelf. Cabinet is to be enclosed by a set of sliding acrylic doors. Per dwg. #5.
	50-10-0705	X	1	DRAWER - SLIDE-OUT / WRITING TABLE STREETSIDE INTERIOR
	50-20-0142	X	1	DELETE DRAWER - SLIDE-OUT / WRITING TABLE STREETSIDE INTERIOR CABINET - FRONT WALL, LOWER #1 Lower front wall #1 shortened to accommodate transverse backboard compartment located below IPOS, per dwg. # 7. Cabinet shall be enclosed with a single right hinged .5" thick LEXAN door IPOS, per dwg. # 7. The door shall be secured with (2) two locking lever latches (1 upper/lower located on left side). Rubber bumpers shall be provided on the cabinet. Ref #6424
	50-20-0145		1	CABINET - FRONT WALL, UPPER #1 This cabinet shall be enclosed by one (1) set of sliding acrylic doors. The compartment shall contain one (1) adjustable shelf.
	50-20-0279		1	CABINET - FRONT WALL, LOWER #2 & #3 - INSIDE/OUTSIDE ACCESS The lower front wall cabinet shall be split into 2 equal sized compartments. Each compartment shall have one (1) adjustable shelf. Install a third adjustable shelf to be used as a divider between the upper and lower cabinets. Install a removable faceplate between the cabinets to allow for possible future cabinet modifications. See dwg #7
	50-20-0381	X	1	DELETE CABINET - FRONT WALL, LOWER BELOW PDQ (SINGLE VENTED DOOR) Deleted
	50-20-0507		1	PASS THROUGH - CAB TO MODULE
	50-30-0111		1	CABINET - RIGHT WALL, REAR WITH (1) DOOR FACING AISLE #1
	50-30-0111	X	1	DELETE CABINET - RIGHT WALL, REAR WITH (1) DOOR FACING AISLE #1 Cabinet has been deleted. Per dwg. #6.

FUNCTION 1		PART NO		S	QTY	DESCRIPTION
	50-30-0137	X	1		1	Cabinet right wall, behind squad bench Install a shallow cabinet with restocking hinge, over the squad bench, (between the angled lights and the back pad) it shall contain a center divider with an adjustable shelf on each side. Build out the squad bench back pads to be flush with the face of the cabinet. There should be a minimum of 15" from the backpads to the edge of the bench cushion (extend the squad bench cushion if necessary).
	50-41-0203		1		1	HEAT/AIR CONDITIONING, PROAIR 4X4 AC/HEAT CORE Install ProAir IW-3856 with 4x4 AC/Heat Core in the upper front wall.
	50-50-0102		1		1	ATTN SEAT - EVS HIBAC, INTEGRAL CHILD, SWIVEL BASE Seat, Attendant - EVS high back, integral child seat, installed on a swivel base,
	50-50-0324	X	1		1	CPR SEAT - NARROW - W/HINGED SEAT BOTTOM - STORAGE BELOW CPR seat (narrow) - lift up seat cushion, storage underneath An automatic latching fastener shall be installed to secure the CPR seat lid in the closed position. IPOS. Per dwg. #5.
	50-51-1001		1		1	CABINET CONSTRUCTION - INTERIOR - ALUMINIUM
	50-51-1011		1		1	RECESSED ADJUSTABLE SHELF TRACK - CABINETS Install recessed adjustable shelf track in cabinets.
	50-51-2001		1		1	CABINET DOORS - BRONZE ACRYLIC Bronze
	50-51-2001	X	1		1	CABINET DOORS LEXAN Clear LEXAN
	50-51-3001		1		1	CABINETS/ WALLS - POLYCHROMATIC COATING - MARBLE STONE Headliner, walls, cabinet faces, and cabinet interiors MultiSpec color to be #99-7371 Marble Stone
	50-51-4011		1		1	COUNTER TOP - SOLID ACRYLIC - RAVEN BOULDER (BLACK) A Megarite solid acrylic counter top, Raven Boulder (black) #810,
	50-51-4056	X	1		1	Counter Top Accent stripe-solid acrylic
	50-51-5001		1		1	UPHOLSTERY - SPRADLING "ARCTIC" CHARCOAL #9017 All cushions, head pads and seating surfaces shall be covered with Spradling International "Arctic" Charcoal # 9017 expanded vinyl upholstery material.
	50-51-6003		1		1	LONPLATE II, NON-SLIP EMBOSSED SM. GRID - GUNMETAL #424 The floor in the patient compartment shall be covered with Lonseal brand "Lonplate II" non-slip, small grid (embossed) Gunmetal #424,
	50-60-0015	X	1		1	Aspirator / suction-Impact #324
	50-60-0030	X	1		1	ASSIST HANDLES, (2) "V" STAINLESS STEEL A total of two (2) stainless steel "V" assist handles shall be provided: two (2) 1-1/4" diameter stainless steel "V" handles, one (1) on each rear passage door. Per dwg. #8.

FUNCTION 1	PART NO	S	QTY	DESCRIPTION
	50-60-0094		1	CLOCK - TRIN TEC, 8" 12/24 HR, QUARTZ BATTERY - FT SQ BENCH Install a Trin Tec battery operated, 12/24 hour clock on the curbside forward facing wall at the foot end of the squad bench
	50-60-0164		1	COT FASTENER - STRYKER POWER LOAD SYSTEM - CENTER POSITION Install Stryker Power Load Cot System IPoS (center position)
	50-60-0325	X	1	Delete Glove dispenser (3) Box curbside
	50-60-0427	X	1	HEAT/AC 125V/12V COMBINATION UNIT FT-454 W/TMC2007 CONDENSER Heat & A/C - FT-454 dual voltage 125v/12v with no heat strip unit includes CM3000 thermostat located per dwg. #5, 20 amp manual eject shoreline, and dual TMC 2007 condenser mounted on front of module. Unit is to have a APS-253 ultraviolet light system. Condenser is to be painted to match the module. Install an aluminum diamond plate protective brush cover on bottom and top of the condenser per dwg. #1.
	50-60-0431		1	I V HANGERS - CEILING RECESSED - CAST PRODUCTS #V2008-1 (2) Two (2) Cast Products #V2008-1 recessed, dual ceiling I.V. hangers shall be provided per Dwg #9 locations.
	50-60-0434	X	1	Perko (2) hangers with velcro straps Install two (2) perko clips and straps. One (1) shall be installed on the streetside above the #2 cabinet per dwg. #5. One (1) shall be installed on the curbside wall above the squad bench per dwg. #6.
	50-60-0437	X	1	I V HANGERS - CEILING RECESSED - CAST PRODUCTS #V2008-1 (4) Two (2) additional Cast Products #V2008-1 recessed, dual, ceiling I.V. hangers shall be provided and installed IATS. Located per dwg. #9.
	50-60-0590		1	NET, SQUAD BENCH - CURBSIDE INTERIOR (RED) Net, Squad Bench - red shall be installed at the head of the squad bench.
	50-60-0612		1	OXYGEN OUTLETS (3) WALL - OHIO MEDICAL TYPE Relocate one (1) oxygen outlet from the ceiling to the left wall forward action area next to the standard outlet.
	50-60-0640	X	1	Oxygen electric system Install Electric Oxygen system IPoS manual (this includes bypass) Oxygen access window is to be located per dwg. #5.
	50-60-0681	X	1	RADIO SPEAKERS, STREETSIDE (OEM RADIO FADER CONTROL) Two (2) stereo speakers shall be installed rear head pad. The fader control for the rear speakers shall be in the cab radio.

FUNCTION 1	PART NO	S	QTY	DESCRIPTION
	50-60-0700	X	1	Sharps in end of squad bench Install a sharps/waste drawer at end of bench IPOS. Drawer opens to aisle and secured with stainless steel flush pull locking latch, per dwg. # 6. (Extends the squad bench cushion.
	50-60-0730		1	DOOR PANELS - MODULE PASSAGE DOORS - FULL LENGTH ALUMINUM - W/ACCESS PANELS Interior rear and curbside passage door panels to be full length aluminum, Multi-Spec sprayed to match interior color and contain removable latch access panel per dwg. # 6 & # 8. (Total 3).
	60-01-0002		1	PAINT MODULE - OEM WHITE Paint module OEM white to match the chassis
	60-10-0110	X	1	PAINT / GRAPHICS PAINT MODULE The entire module shall be sprayed one-color and then clear coated. The PPG paint code is 91 1659 Red.
	60-10-0170	X	1	CAB PAINT Cab is to be painted per the attached layout. The PPG paint code is 91 1659 Red.
	60-20-0303	X	1	CHEVRON STRIPING - PERIMETER - NO DOORS Red/Yellow Reflexite chevron striping 6" wide shall be installed on the perimeter of the rear module, not on the doors.
	60-25-0101		1	Included with graphics package under #60-SP-0001 BLACK REFLECTIVE MATERIAL IN RUB RAILS Install black reflective material in rub rails.
	60-SP-0001	X	1	PAINT AND GRAPHICS - SPECIAL OPTION Please use graphics and paint scheme same as unit #6424 Paint module roof OEM white over the roof radius to drip rail level (no drip rails) per photo #6424 See #60-10-0110, #60-10-0170-10 and 60-SP-0001
	60-SP-0011	X	1	GRAPHICS Graphics are to be per the attached layout.
	AE-TS-0001	X	1	System switches Remove the cab vista from the floor console and install on a fixed mount in cab dash similar to Bellevue 5287. (If this install can not be completed without blocking OEM dash heat/ac controls, any other dash items or places the Vista in an greatly indirect view of the driver seat, remove the heat/ac controls to the top of the open angled console area, per photo reference).

FUNCTION 1	PART NO	S	QTY	DESCRIPTION
	SE-99-0002	X	1	HANSON ASSIST HANDLES Install (5) Austin # AE9-01228 polyurethane door assist handles (POS, Two (2) at rear doors, two (2) at curbside door, and one (1) on curbside door, per dwgs.
	SP-99-0001	X	1	Pre-wires (3) 12V Three (3) 12v prewires shall be installed in the module. One (1) each at the cab floor console and one (1) at the ACP in the primary action area, and one (1) for the thermal imaging camera above the console.
	SP-99-4000	X	1	Cole Hersee switch Install a battery switch, Cole Hersee with cover plate left of drivers seat. Battery switch to control chassis and module - items wired hot, must stay hot and OEM radio to retain memory
	SP-99-4001	X	1	Buss Bar Install one (1) 30 Buss bar in the PDQ IATS.
	SP-99-4011	X	1	Cabinet, Drawer Curbside (2) Install (2) pull out drawers at the rearward end of the squad bench opening towards aisle. Drawers, per dwg. dimensions. Drawers secured with stainless steel Southco locking latches and an additional cylinder key lock (1) # KV-70 on each drawer IATS, per dwg. # 6. Both drawers to lock in the out position using locking drawer slides. Dimensions revised from unit # 6424
	SP-99-4013	X	1	Cabinet, Drop down, pass thru Install a solid acrylic counter top beneath the pass through opening. This is due to the build out from the transverse back board storage. Countertop colors are to match the streetside countertop colors. Install a cabinet above the pass through opening. Cabinet is to be built and located per dwg. #7 dimensions. Cabinet is to be enclosed by a drop down acrylic door. Door is to be secured with a locking lever latch. Per dwg. #7.