

RESOLUTION NO. 2015 - 39

A RESOLUTION BY THE BOARD OF COUNTY COMMISSIONERS OF ST. JOHNS COUNTY, FLORIDA, AUTHORIZING THE COUNTY ADMINISTRATOR, OR DESIGNEE, TO AWARD BID NO. 15-28 AND TO EXECUTE A PURCHASE ORDER FOR THE PURCHASE OF FOUR (4) 2015 16,500 GVWR EXTENDED CAB TRUCKS, 4X2 WITH SERVICE BODY AND 4,000 LB. CRANE WITH 26,000 GCWR (LIFT STATION DIVISIONS)

RECITALS

WHEREAS, the County desires to enter into a contract with Hub City Ford to purchase four (4) 2015 16,500 GVWR Extended Cab Trucks, 4X2 with Service Body and 4,000 lb. Crane with 26,000 GCWR for the purpose of providing new and replacement trucks for the Utility Department Lift Station Divisions; and

WHEREAS, through the County's formal bid process, Hub City Ford was selected as the most qualified respondent to enter into a contract with the County for the purpose referenced above; and

WHEREAS, the project is being funded by the Utility Department Services Fund and Ponte Vedra Utility Services Fund; and

WHEREAS, said purchase serves a public purpose.

NOW, THEREFORE BE IT RESOLVED BY THE BOARD OF COUNTY COMMISSIONERS OF ST. JOHNS COUNTY, FLORIDA:

Section 1. The above Recitals are incorporated by reference into the body of this Resolution and such Recitals are adopted as finds of fact.

Section 2. The County Administrator, or his designee, is hereby authorized to award Bid No. 15-28 to Hub City Ford, and further authorized to execute a purchase order on behalf of the County for the purchase of four (4) 2015 16,500 GVWR Extended Cab trucks, 4X2 with Service Body and 4,000 lb. Crane with 26,000 GCWR in the amount of \$238,748.00.

Section 3. To the extent that there are typographical and/or administrative errors that do not change the tone, tenor, or concept of this Resolution, then this Resolution may be revised without subsequent approval by the Board of County Commissioners.

PASSED AND ADOPTED by the Board of County Commissioners of St. Johns County, Florida, this 17th day of February, 2015.

ATTEST: Cheryl Strickland, Clerk

By: Pam Halterman
Deputy Clerk

BOARD OF COUNTY COMMISSIONERS
OF ST. JOHNS COUNTY, FLORIDA

By: [Signature]
Priscilla L. Bennett, Chair

RENDITION DATE 2/19/15

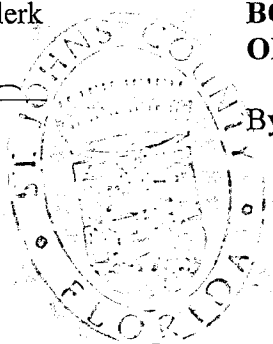



ST. JOHNS COUNTY
PURCHASING DEPARTMENT

500 San Sebastian View
St. Augustine, Florida 32084

INTEROFFICE MEMORANDUM

TO: Jeff Nordsiek, Fleet Maintenance Manager
Frank Kenton, Assistant Director of Utilities

FROM: Leigh Daniels, CPPB, Senior Buyer *LD*

SUBJECT: Transmittal of Bids Received for Bid No. 15-28, Purchase of Four (4) 2015 16,500
GVWR Extended Cab Trucks, 4X2 with Service Body and 4,000 lb. Cane with 26,000
GCWR (Lift Stations Division)

January 7, 2015

Attached are copies of the bid proposals received for the above mentioned along with a copy of the Bid Tabulation Sheet.

Please review, evaluate and make a written recommendation for this project. Also, indicate the budgeted amount for this item along with the appropriate charge code and return at your earliest convenience. We will prepare the agenda item and contract.

Please let me know if I can assist your department in any other way.

Fleet Manager Approval *[Signature]* Date 1-9-2015

Department Head Approval C J Kenton

Date 1/15/15

Budget Amount Main - 183,000 PV - 46,000

Account Funding Title LS Equipment & PV LS Equipment

Funding Charge Code 4416-56400 & 4474-56400

Award to HUB CITY FORD

Award Amount \$238,748.00

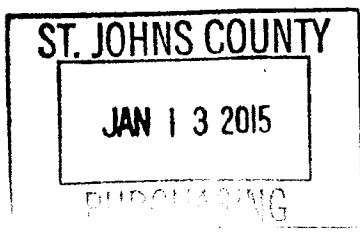
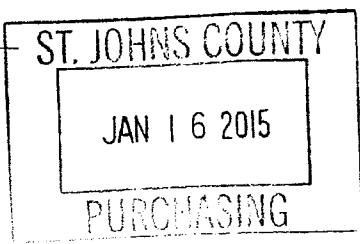

**ST. JOHNS COUNTY
BID TABULATION**

BID TITLE PURCHASE OF FOUR (4) 2015 16,500 GVWR EXTENDED CAB TRUCKS, 4X2 WITH SERVICE BODY AND 4,000 LB. CRANE WITH 26,000 GCWR- LIFT STATION DIVISION
BID NUMBER 15-28
OPENING DATE/TIME January 7, 2015 2:00 PM

POSTING DATE/TIME 01/07/15 3:00 PM
FROM UNTIL 01/12/15 3:00 PM

ANY BIDDER AFFECTED ADVERSELY BY AN INTENDED DECISION WITH RESPECT TO THE AWARD OF ANY BID, SHALL FILE WITH THE PURCHASING DEPARTMENT FOR ST. JOHNS COUNTY, A WRITTEN NOTICE OF INTENT FILE A PROTEST NOT LATER THAN SEVENTY-TWO (72) HOURS (EXCLUDING SATURDAY, SUNDAY AND LEGAL HOLIDAYS) AFTER THE POSTING OF THE BID TABULATION PROTEST PROCEDURES MAY BE OBTAINED IN THE PURCHASING DEPARTMENT.

OPENED BY _____
 TABULATED BY _____
 VERIFIED BY _____

LEIGH DANIELS
 LILA HARTLAND

BIDDERS	TOTAL PACKAGE BID PRICE	UNIT PRICE	MAKE/MODEL	DELIVERY DATE			
BECK FORD LINCOLN	\$245,560.00	\$61,390.00	FORD F450	180 DAYS ARO			
BILL CURRIE FORD INC	\$241,648.00	\$60,412.00	FORD F450	100 DAYS ARO			
JARRETT GORDON FORD	\$240,234.24	\$60,058.56	FORD F450	90-120 DAYS			
HUB CITY FORD	\$238,748.00	\$59,687.00	FORD F450	120-160 DAYS			
BARTOW FORD COMPANY	\$246,572.00	\$61,643.00	FORD F450	110-180 DAYS			

BID AWARD DATE - _____

BID NO: 15-28

**ST. JOHNS COUNTY, FLORIDA
OFFICIAL TOTAL BID FORM**

TO: THE BOARD OF COUNTY COMMISSIONERS
OF ST. JOHNS COUNTY, FLORIDA

DATE: 01-06, 2015

-BID PROPOSAL-

If awarded a Purchase Order on the basis of this proposal, the undersigned pledges to provide the equipment as specified in the Bid Proposal and County Specifications barring delays due to strikes, fires, transportation difficulties or other causes beyond the control of the undersigned.

The undersigned declares that the statements and representations made in this proposal are true in every respect and that the said proposal is in all respects fair and made without collusion or fraud, and that no member of the County Board, or any other agent or employee of the County, directly or indirectly, is interested in this proposal or in any profits expected to accrue therefrom.

The following proposal is presented:

FOR: **PURCHASE OF FOUR (4) 2015 16,500 GVWR EXTENDED CAB TRUCK, 4X2 WITH SERVICE BODY AND 4,000 LB CRANE WITH 26,000 GCWR, PER ATTACHED SPECIFICATIONS:**

TOTAL PACKAGE BID \$ 238,748.00
(Cost of Four Trucks)

UNIT PRICE \$ 59,687.00

MAKE/MODEL FORD F-450

DELIVERY DATE: 120-160

**Bid No: 15-28 Official Total Bid Form for the Purchase of Four (4) 2015 16,500
GVWR Extended Cab Truck, 4X2 with Service Body and 4,000 lb. Crane with 26,000
GCWR**

I certify that the equipment presented in the above proposal meets or exceeds the County specifications and that I, the undersigned bidder, declare that I have carefully examined the specifications, terms and conditions of this bid and I am thoroughly familiar with its provisions and quality and type of coverage called for and bid herein. The undersigned further declares that he has not divulged, discussed or compared his bid with any other bidders and has not colluded with any other bidder or parties to a bid whatsoever for any fraudulent purpose.

COMPANY: HUB CITY FORD INC

ADDRESS: 4060 SOUTH FERDON BLVD

CRESTVIEW FLA,32536

MINORITY OR WOMAN OWNED BUSINESS: MINORITY

FEDERAL ID NO. OR SOCIAL SECURITY NO.: 59-2617784

SIGNATURE: _____

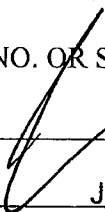

JOESPH WINDROW

(Typed or Printed Signature)

TITLE: FLEET SALES MGR

DATE: 01-06-2015

TELEPHONE NO.: 850-398-6810

FAX NO.: 850-398-6827

EMAIL ADDRESS: WINDROW1@WINDROWFLEETSALES.COM

ATTACHMENT "A"

ST. JOHNS COUNTY BOARD OF COUNTY COMMISSIONERS

AFFIDAVIT

TO: ST. JOHNS COUNTY BOARD OF COUNTY COMMISSIONERS
ST. AUGUSTINE, FLORIDA

At the time the proposal is submitted, the Bidder shall attach to his bid a sworn statement.

The sworn statement shall be an affidavit in the following form, executed by an officer of the firm, association or corporation submitting the proposal and shall be sworn to before a person who is authorized by law to administer oaths.

STATE OF FLORIDA _____ COUNTY OF OKALOOSA _____. Before me, the undersigned authority, personally appeared JOSEPH WINDROW who, being duly sworn, deposes and says he is FLEET SALES MGR (Title) of HUB CITY FORD ,INC (Firm) the bidder submitting the attached proposal for the services covered by the bid documents for Bid No: 15-28, Purchase of Four (4) 2015 16,500 GVWR Extended Cab Truck, 4X2 with Service Body and 4,000 lb. Crane with 26,000 GCWR St. Johns County.

The affiant further states that no more than one proposal for the above referenced project will be submitted from the individual, his firm or corporation under the same or different name and that such bidder has no financial interest in the firm of another bidder for the same work. That he, his firm, association or corporation has neither directly, nor indirectly entered into any agreement, participated in any collusion or otherwise taken any action in restraint of free competitive bidding in connection with this firm's bid on the above described project. Furthermore, neither the firm nor any of it's officers are debarred from participating in public contract lettings in any other state.

HUB CITY FORD INC
(Bidder)
By _____
FLEET SALES MGR
(Title)

Sworn and subscribe to before me this 6 day of JAN 2015.

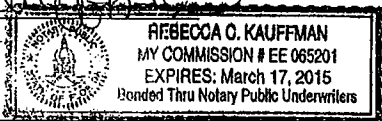
Rebecca C. Kauffman
Notary Public
My Commission Expires: _____

BIDDER ON ALL COUNTY PROJECTS MUST EXECUTE & ATTACH THIS AFFIDAVIT TO EACH BID.

BID NO: 15-28

NOTICE TO BIDDERS

Notice is hereby given that sealed bids will be accepted until **2:00 P.M. on January 7, 2015** by Leigh Daniels, CPPB, Senior Buyer, St. Johns County Purchasing Department, 500 San Sebastian View, St. Augustine, Florida 32084, (904) 209-0154, for **Purchase of Four (4) 2015 16,500 GVWR Extended Cab Truck, 4X2 with Service Body and 4,000 lb. Crane with 26,000 GCWR.** Bids will be opened promptly after the 2:00 p.m. deadline. **Note:** Bids delivered or received in the Purchasing Department after the 2:00 P.M. deadline shall not be given consideration and shall be returned to the sender unopened.

Any and all procurement questions shall be directed to Leigh Daniels, CPPB, Senior Buyer, St. Johns County Purchasing, phone number (904) 209-0154 or email ldaniels@sjcfl.us . The deadline for all questions shall be no later than 4:00 p.m., Monday, December 29, 2014.

Package request forms are available on DemandStar.com and requesting Document # **15-28**. Additionally, document orders may be facilitated through Onvia DemandStar, Inc. For technical assistance with this Website please contact Onvia Supplier Services at 1-800-711-1712. A link to Onvia DemandStar is also available through the St. Johns County Website at www.sjcfl.us/BCC/Purchasing/Open_Bids.aspx. Check the County's site for download availability and any applicable fees. Vendors registered with Onvia DemandStar.com may visit www.demandstar.com to electronically download some documents.

Vendors shall not contact, lobby, or otherwise communicate with any St. Johns County employee, including any member of the Board of County Commissioners, other than the above referenced individual from the point of advertisement of the Bid until contract(s) are executed by all parties, per St. Johns County Purchasing Code 304.6.5 "Procedures Concerning Lobbying". According to St. Johns County policy, any such communication shall disqualify the vendor, contractor, or consultant from responding to the subject invitation to bid, request for quote, request for proposal, invitation to negotiate, or request for qualifications.

St. Johns County reserves the right to accept or reject any or all bids/proposals, waive minor formalities, and to award the bid/proposal that best serves the interests of St. Johns County. St. Johns County also reserves the right to award the base bid and any alternate bids in any combination that best suits the needs of the County.

BOARD OF COUNTY COMMISSIONERS
OF ST. JOHNS COUNTY, FLORIDA
CHERYL STRICKLAND, CLERK

BY: _____
DEPUTY CLERK

ST. JOHNS COUNTY
PURCHASING DEPARTMENT

INSTRUCTIONS TO BIDDERS

These instructions will bind bidders to terms and conditions herein set forth, except as specifically qualified in special bid contract terms issued with any individual bid.

1. The following criteria are used in determining low responsible bidder:
 - A. The ability, capacity and skill of bidder to perform required service.
 - B. Whether bidder can perform service promptly or within specified time.
 - C. The character, integrity, reputation, judgement, experience and efficiency of bidder.
 - D. The performance of previous contracts with St. Johns County.
 - E. The suitability of equipment of material for county use.
 - F. The ability of bidder to provide future maintenance and parts service.
2. Payment terms are net thirty (30) days unless otherwise specified. Favorable terms, discounts may be offered and will be considered in determining low bids if they are deemed by the Purchasing Department advantageous to the County.
3. All bids should be tabulated, totaled and checked for accuracy. Unit price will prevail in case of errors.
4. All requested information should be included in the bid envelope or your bid may not receive full consideration.
5. If anything of the bid request is not clear, you should contact the Purchasing Department immediately.
6. A bidder's list is available at the Purchasing Office.
7. Quote all prices F.O.B. (Free On Board), our warehouse or as specified in bid documents.
8. Each proposal shall be clearly marked on the outside of the envelope with the following:
 - A. Sealed Bid Number
 - B. Name of Item Being Bid in Full
 - C. Vendor name and address
9. No Responsibility will attach to any County representative or employee for the premature opening of bid not properly addressed or identified.
10. If only one (1) bid is received, the bid may be rejected and re-advertised.
11. Bids received late will not be accepted and the County will not be responsible for late mail delivery. However, should a bid be misplaced by the County and found later, will be considered.
12. Telephone and facsimile bid will not be acceptable in formal Sealed Bids openings.
13. Any bidder may request and shall receive a receipt showing the day and hour any bid is delivered to the appropriate office of the County from the personnel thereof.
14. All bidders must be recognized dealers in the materials of equipment specified and be qualified to advise in their application or use. A bidder may at any time be requested to satisfy the Purchasing Office and the County Administrator that he has the requisite organization, capital, plant, stock, ability and experience to satisfactorily execute the contract in accordance with the provisions of the contract in which he is interested.
15. Any alterations, erasures, additions or omissions of required information or any changes of specifications or bidding schedule is done at risk of the bidder. Any bid will be rejected that has a substantial variation. For example, a variation that affects the price, quality or delivery date (when delivery is required by a specific time).
16. When requested, samples will be furnished to the County free of expense, properly marked for identifications and accompanied by a list where there is more than one (1) sample. The County reserves the right to mutilate or destroy any sample submitted whenever it may be to the interest of the County to do so for the purpose of testing.
17. The County will reject any material, supplies or equipment that do not meet the specifications, even though the bidder lists the trade names or names of such material on the bid or price quotation form.
18. The unauthorized use of patented articles is done entirely at the risk of the successful bidder.

19. The ESTIMATED QUANTITY given in the specifications of advertisements is for the purpose of bidding ONLY. The County may purchase more or less than the estimated quantity and the vendor must not assume that such estimated quantity is part of the contract.
20. Only the latest model equipment, as evidenced by the manufacturer's current published literature will be considered. Obsolete models of equipment not in production will not be acceptable. The equipment shall be composed of new parts and materials. Any unit containing used parts or having seen any service other than the necessary tests will be rejected. In addition to the equipment specifically called for in the specification, all equipment catalogued by the manufacturer as standard or required by the State of Florida shall be furnished with the equipment. Where required by the State of Florida Motor Vehicle Code, vehicles shall be inspected and bear the latest inspection sticker of the Florida Department of Revenue.
21. The successful bidder on motor vehicle equipment shall be required to furnish with the delivery of the vehicle a certificate of origin and any other appropriate documentation as required by the Florida Motor Vehicle Department.
22. Prospective bidders are required to examine the location of the proposed work or delivery and determine, in their own way, the difficulties, which are likely to be encountered in the prosecution of the same.
23. All materials, equipment and supplies shall be subjected to rigid inspection under the immediate supervision of the Purchasing Department, its designee and/or the department to which they are delivered. If defective material, equipment or supplies are discovered, the vendor shall remove or make good such material, equipment or supplies without extra compensation. It is expressly understood and agreed that the inspection of materials by the County will in no way lessen the responsibility of the vendor or release him from his obligation to perform and deliver to the County sound and satisfactory materials, equipment or supplies. The vendor agrees to pay the costs of all test upon defective material, equipment or supplies or allow the cost to be deducted from any monies due him from the County.
24. Unless otherwise specified, the County reserves the right to award each item separately or on a lump sum basis, whichever is in the best interest of the County.
25. A contract may not be awarded to any corporation, firm or individual who is, from any cause, in arrears to the County or who has failed in former contracts with the County.
26. Reasonable grounds for supposing that any bidder is interested in more than one proposal for the same item will be considered sufficient cause for rejection of all proposals in which he is interested.
27. Submitting a proposal when the bidder intends to sublet the contract may be a cause for rejection of bids or cancellation of the contract by the County Administrator.
28. The County reserves the right to reject any or all bids or quotations, to waive any minor discrepancies in the bids for all bidders equally when deemed to be in the best interest of the County and to purchase any part, all or none of the materials, supplies or equipment specified.
29. Failure of the bidder to sign the bid or have the signature of any authorized representative or agent on the bid proposal in the space provided may be cause for rejection of the bid. Signature must be written in ink or indelible pencil. Typewritten or printed signatures will not be acceptable.
30. Any bidder may withdraw his bid at any time BEFORE the time set of opening of the bids. A bid may be withdrawn AFTER the bids are opened only with permission of the Purchasing Agent.
31. It is mutually understood and agreed that, if at any time, the Purchasing Department or designee shall be of the opinion that the contract, or any part thereof, is unnecessarily delayed or that the rate of progress or delivery is unsatisfactory or that the contractor is willfully violating any of the condition or covenants of the agreement or is executing the same in bad faith, the Purchasing Agent or his designee shall have the power to notify the aforesaid contractor of the nature of the complaint. Notification shall constitute delivery of notice or letter to address given in proposal. If after three (3) working days of notification, the conditions are not corrected to the satisfaction of the Purchasing Agent, he shall thereupon have the power to take whatever action he may deem necessary to complete the work or delivery herein described, or any part thereof, and the expense thereof, so charged, shall be deducted from any paid by the County out of such monies as may become due to the said contractor, under and by virtue of this agreement. In case such expense shall exceed the last said sum, then and in that event, the bondsman or the

contractor, his executors, administrators, successors or assigns, shall pay the amounts of such excess to the County on notice by the Purchasing Department or his designee of the excess due.

32. Any complaint from bidders relative to the invitation to bid or any attached specifications shall be made prior to the time of opening bids, otherwise, the bidder waives any such complaint.
33. A vendor writing specifications for the County may not be allowed to bid on that project.
34. Contracts may be canceled by the County with or without cause on thirty (30) days advance written notice.
35. Any bidder affected adversely by an intended decision with respect to the award of any bid, shall file with the Purchasing Department for St. Johns County, a written notice of intent to file a protest not later than seventy-two (72) hours (excluding Saturday, Sunday and legal holidays) after the posting of the bid tabulation. Protest procedures may be obtained in the Purchasing Department.
36. Vendors shall not contact, lobby, or otherwise communicate with any St. Johns County employee, including any member of the Board of County Commissioners, other than the above referenced individual from the point of advertisement of the Bid until contract(s) are executed by all parties, per St. Johns County Purchasing Code 304.6.5 "Procedures Concerning Lobbying". According to St. Johns County policy, any such communication shall disqualify the vendor, contractor, or consultant from responding to the subject invitation to bid, request for quote, request for proposal, invitation to negotiate, or request for qualifications.

BID NO: 15-28

**ST. JOHNS COUNTY, FLORIDA
OFFICIAL TOTAL BID FORM**

TO: THE BOARD OF COUNTY COMMISSIONERS
OF ST. JOHNS COUNTY, FLORIDA DATE: _____, 2015

-BID PROPOSAL-

If awarded a Purchase Order on the basis of this proposal, the undersigned pledges to provide the equipment as specified in the Bid Proposal and County Specifications barring delays due to strikes, fires, transportation difficulties or other causes beyond the control of the undersigned.

The undersigned declares that the statements and representations made in this proposal are true in every respect and that the said proposal is in all respects fair and made without collusion or fraud, and that no member of the County Board, or any other agent or employee of the County, directly or indirectly, is interested in this proposal or in any profits expected to accrue therefrom.

The following proposal is presented:

FOR: **PURCHASE OF FOUR (4) 2015 16,500 GVWR EXTENDED CAB TRUCK, 4X2 WITH SERVICE BODY AND 4,000 LB CRANE WITH 26,000 GCWR, PER ATTACHED SPECIFICATIONS:**

TOTAL PACKAGE BID \$ _____
(Cost of Four Trucks)

UNIT PRICE \$ _____

MAKE/MODEL _____

DELIVERY DATE: _____

**Bid No: 15-28 Official Total Bid Form for the Purchase of Four (4) 2015 16,500
GVWR Extended Cab Truck, 4X2 with Service Body and 4,000 lb. Crane with 26,000
GCWR**

I certify that the equipment presented in the above proposal meets or exceeds the County specifications and that I, the undersigned bidder, declare that I have carefully examined the specifications, terms and conditions of this bid and I am thoroughly familiar with its provisions and quality and type of coverage called for and bid herein. The undersigned further declares that he has not divulged, discussed or compared his bid with any other bidders and has not colluded with any other bidder or parties to a bid whatsoever for any fraudulent purpose.

COMPANY: _____

ADDRESS: _____

MINORITY OR WOMAN OWNED BUSINESS: _____

FEDERAL ID NO. OR SOCIAL SECURITY NO.: _____

SIGNATURE: _____

(Typed or Printed Signature)

TITLE: _____

DATE: _____

TELEPHONE NO.: _____

FAX NO.: _____

EMAIL ADDRESS: _____

**Bid No: 15-28 Official Total Bid Form for the Purchase of Four (4) 2015 16,500
GVWR Extended Cab Truck, 4X2 with Service Body and 4,000 lb. Crane with 26,000
GCWR**

Remarks to Bidder:

Bids must be submitted in **TRIPLICATE!** Bids must be placed in an envelope, sealed and plainly marked **SEALED BID NO. 15-28, PURCHASE OF FOUR (4) 2015 16,500 GVWR EXTENDED CAB TRUCK, 4X2 WITH SERVICE BODY AND 4,000 LB CRANE WITH 26,000 GCWR**

The company name must be indicated on the envelope, also.

All bids must be signed manually by a responsible officer of your company in ink or indelible pencil.

If there are any exceptions to the bid proposal or specifications, please state here or on attached sheet.

Attachment "A" affidavit must be completed and attached to bid proposal.

St. Johns County reserves the right to accept or reject any or all bids/proposals, waive minor formalities, and to award the bid/proposal that best serves the interests of St. Johns County. St. Johns County also reserves the right to award the base bid and any alternate bids in any combination that best suits the needs of the County.

ATTACHMENT "A"

ST. JOHNS COUNTY BOARD OF COUNTY COMMISSIONERS

AFFIDAVIT

TO: ST. JOHNS COUNTY BOARD OF COUNTY COMMISSIONERS
ST. AUGUSTINE, FLORIDA

At the time the proposal is submitted, the Bidder shall attach to his bid a sworn statement.

The sworn statement shall be an affidavit in the following form, executed by an officer of the firm, association or corporation submitting the proposal and shall be sworn to before a person who is authorized by law to administer oaths.

STATE OF _____ COUNTY OF _____. Before me, the undersigned authority, personally appeared _____ who, being duly sworn, deposes and says he is _____ (Title) of _____ (Firm) the bidder submitting the attached proposal for the services covered by the bid documents for Bid No: 15-28, Purchase of Four (4) 2015 16,500 GVWR Extended Cab Truck, 4X2 with Service Body and 4,000 lb. Crane with 26,000 GCWR St. Johns County.

The affiant further states that no more than one proposal for the above referenced project will be submitted from the individual, his firm or corporation under the same or different name and that such bidder has no financial interest in the firm of another bidder for the same work. That he, his firm, association or corporation has neither directly, nor indirectly entered into any agreement, participated in any collusion or otherwise taken any action in restraint of free competitive bidding in connection with this firm's bid on the above described project. Furthermore, neither the firm nor any of it's officers are debarred from participating in public contract lettings in any other state.

(Bidder)

By _____

(Title)

Sworn and subscribe to before me this _____ day of _____ 2015.

Notary Public

My Commission Expires: _____

BIDDER ON ALL COUNTY PROJECTS MUST EXECUTE & ATTACH THIS AFFIDAVIT TO EACH BID.

Bid No. 15-28

SPECIFICATIONS

**THE BOARD OF COUNTY COMMISSIONERS
OF ST. JOHNS COUNTY, FLORIDA**

MINIMUM SPECIFICATIONS

FOR: FOUR (4) 2015 16,500 GVWR EXTENDED CAB TRUCK, 4X2 WITH SERVICE BODY AND 4,000 LB. CRANE WITH 26,000 GCWR, TO MEET MANUFACTURER'S BASIC PRODUCTION MODEL STANDARDS, EQUIPPED WITH ALL STANDARD EQUIPMENT LISTED IN THE MANUFACTURER'S LITERATURE IF NOT LISTED IN SPECIFICATIONS BELOW:

**CHRYSLER, FORD, GENERAL MOTORS OR APPROVED EQUIVALENT
ALL ITEMS FACTORY INSTALLED UNLESS OTHERWISE INDICATED**

This bid is for the Utility Department's Lift Stations Division.

1. ENGINE

- a. Manufacturer's standard gasoline engine, minimum 350 HP with **CNG Gaseous Engine Prep Package**.
- b. Manufacturer's heavy duty alternator, minimum 100 amps.
- c. Manufacturer's maintenance free heavy duty battery, minimum 750 CCA.
- d. Manufacturer's heavy duty cooling system.

2. TRANSMISSION

- a. Manufacturer's standard automatic 5 speed transmission with overdrive with transmission oil cooler.
- b. Manufacturer's minimum 4.88 axle ratio for specified engine and transmission combination.
- c. Limited slip differential.

3. PERFORMANCE ITEMS

- a. Manufacturer's standard power steering.
- b. Manufacturer's standard gauges.
- c. Heavy duty front and rear shocks
- d. Up fitter switches (4)

4. COMFORT ITEMS

- a. Manufacturer's standard air conditioning with 134A system.
- b. Manufacturer's standard tinted glass all around.
- c. Window film; Huper Optik Extreme 35 film on glass all around except for windshield shall have a 4" strip on the upper edge.
- d. Manufacturer's standard AM/FM radio.
- e. Heavy-duty rubber floor covering instead of carpet.
- f. OEM Power windows and door locks with keyless remotes.
- g. Manufacturer's standard production seats. **GREY color.**
- h. Keys: Three (3) per vehicle, single key locking system.

Bid No: 15-28

5. BRAKES

- a. Four wheel anti-lock brake ABS system.

6. SAFETY ITEMS

- a. Mirrors, dual Manual with manual fold & manual telescoping trailer tow, to provide field of vision for vehicles to 96" wide.
- b. Interior dome light(s), with left and right door activated switches.
- c. Manufacturer's standard air bags.
- d. Daytime running lights, if available.
- e. OEM running boards or cab steps.

7. TIRES AND WHEELS

- a. Manufacturer's standard tires, 19.5 rims.
- b. Conventional spare tire and rim.
- c. Jack hydraulic minimum 6-ton with handle and lug wrench.

8. CHASSIS, FRAME, CAB

- a. Manufacturer's standard white paint.
- b. Manufacturer's standard fuel tank.
- c. Manufacturer's chrome front bumper.
- d. Trailer tow package for 30,000 GCWR including tow command with electric brake controller, to include heavy-duty flashers, wiring for trail plug (7-prong round), with receiver hitch mounted under rear bumper.
- e. Temporary Tag

9. CONDITIONS

In addition to equipment specified, vehicle shall be equipped with all standard equipment as specified by the manufacturer for this model and shall comply with all EPA Emission Standards and all Motor Vehicle Safety Standards as established by the U.S. Department of Transportation regarding the manufacture of motor vehicles.

The successful bidder shall be responsible for delivering vehicles that are properly serviced, clean and in first class operating condition. Pre-delivery service, at a minimum, shall include the following:

- a. Complete lubrication.
- b. Check all fluid levels to assure proper fill.
- c. Adjustment of engine to proper operating condition.
- d. Inflate tires to proper pressure.
- e. Check to assure proper operation of all accessories, gauges, lights, and mechanical features.
- f. Focusing of headlights.
- g. Cleaning of vehicles, if necessary, and removal of all unnecessary tags, stickers, papers, etc.

DO NOT remove window price sticker or supplied line sheet.

Bid No: 15-28

108" SERVICE BODY SPECIFICATIONS DRW, 60"CA

- General Outside Body Dimensions: 108" Long, 94" Wide, 40" Tall, Compartment Width 21 1/2" and 52" wide between inside of compartment walls.

Front Bulkhead:

- Master Lock System – Master door bar lock security system built into body, with front of bars capable of locking with a padlock and master locking security shields.
- Bright aluminum tread plate gravel guard shall cover complete front body panels.
- Sterling Equipment Manufacturing combination cab guard light bar mount with expanded metal screen with a road side top corner mounted plate with a Radio Ray Go-light wired to a cab mounted on-off switch (up-fitter switch) with a wireless remote controller. A single top center mounted plate (16"X8") with a Star Warning System amber LED flashing light bar, model 9016 controlled from a single switch (up-fitter switch). Cab guard/light bar mount shall be bolt mounted at the front bulkhead.

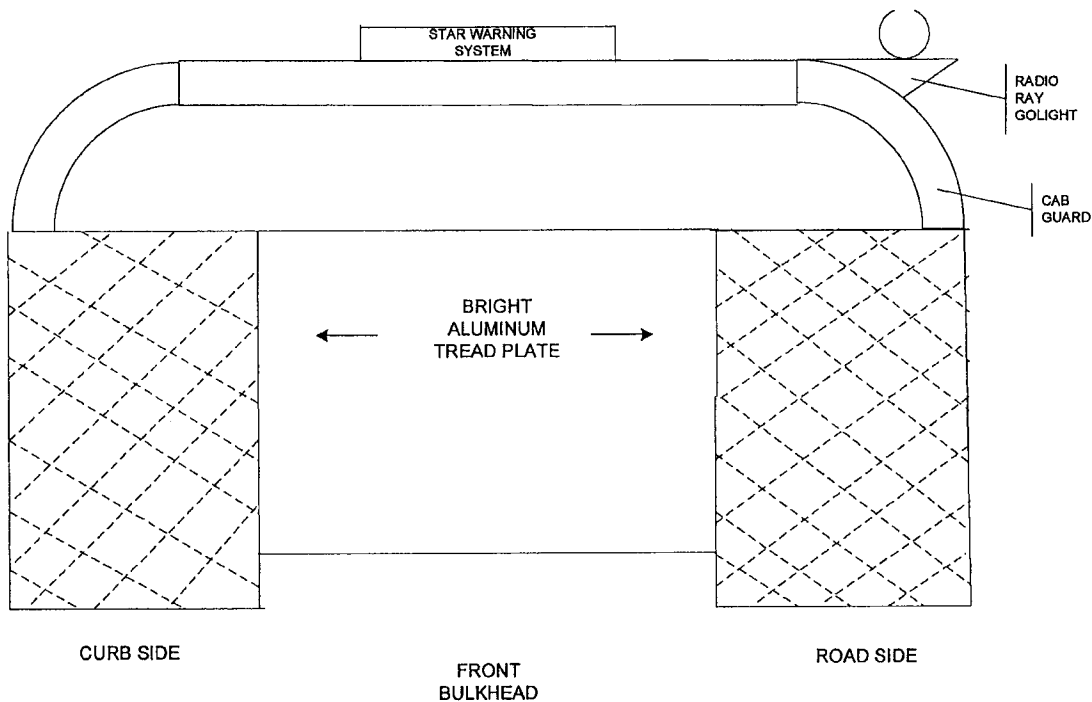

Curb Side Compartments:

- Front compartment 29" wide with 2 stationary shelves with adjustable dividers.
- Horizontal compartment 45" wide shall have (1) stationary divider shelf.

Bid No: 15-28

- Rear vertical compartment 20" wide X 35" tall shall be reinforced for mounting a 4,000 lb electric over hydraulic crane, with second 12 volt battery and one stationary shelf.
- 1000w power inverter hard-wired and mounted in rear vertical compartment.
- Crane, 4,000 lb capacity electric over hydraulic at a 4' hook radius with power boom extension from 8' to 16' with 360 degree continuous power rotation with automatic overload protection system with anti-two block system with 80' of 5/16" aircraft quality cable with removable WIRELESS remote control pendant. Crane and mounting shall meet OSHA 1910.180 requirements, ANSI B30.5 safety standards. Boom rest shall be placed on the top of the curbside compartment reinforced to prevent body flex.

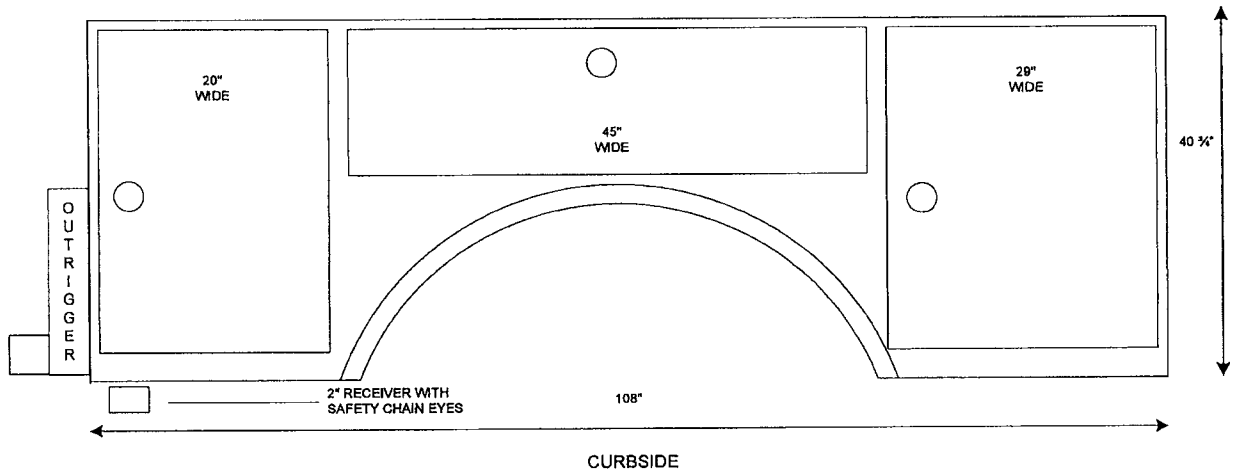

Street Side Compartments:

- Front vertical compartment 29" wide shall have two (2) stationary shelves with adjustable dividers.
- Horizontal compartment 45" wide with no shelves.
- Rear vertical compartment 20" wide X 35" tall shall have one (1) adjustable divider shelf.
- One (1) 14 gal wash water tank model T4016N Chemical Corporation Inc. PO Box 1307, Lake Wales, FL. 33859 (863) 638-1407, with a plastic ball-type on/off spout, bolt mounted on the top left side at rear of compartment.
- One (1) 6" diameter 108" in length PVC pipe storage holder with Blaylock BLI-020 lid, cap and bracket assembly bolt mounted stacked on compartment top.

Bid No: 15-28

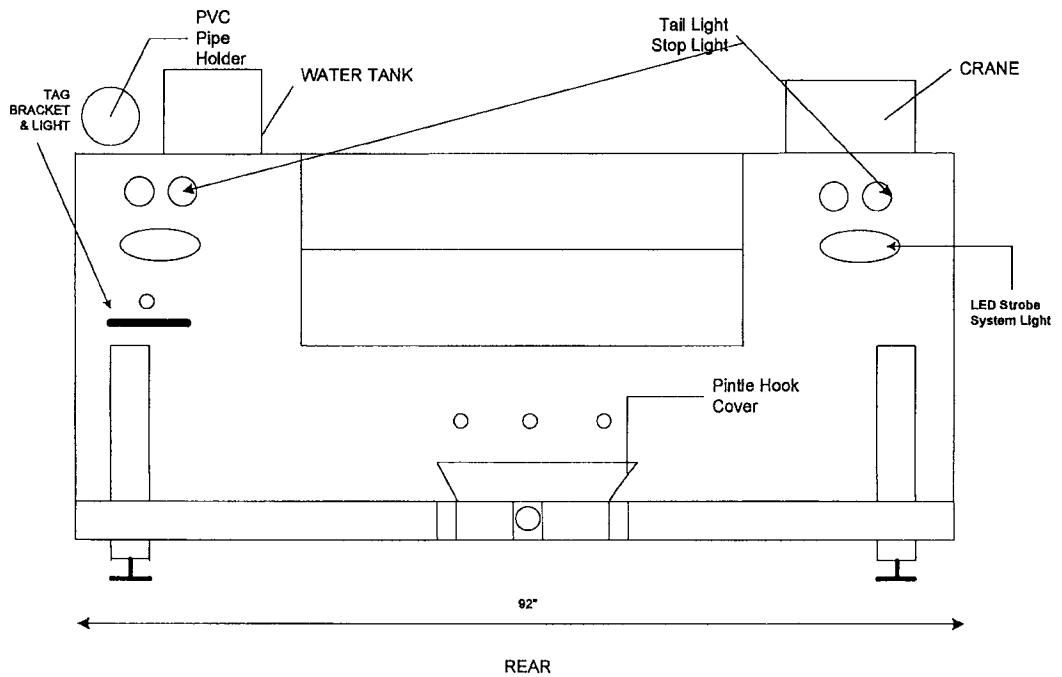
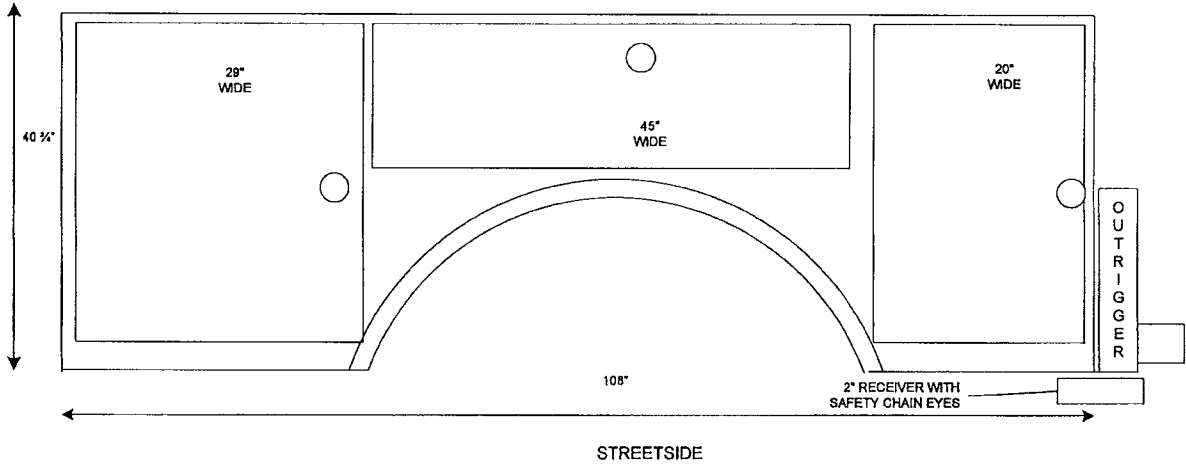

Bid No: 15-28

Rear:

- Heavy duty tailgate, 14 gauge two-sided A40 galvanized steel, double panel doors with hat section reinforcements, with stainless steel slam lock handle with hidden steel support cables capable of supporting 500lbs.
- Outriggers shall be of the same manufacture as the 4,000 lb crane with manual pull out, quick release vertical legs and dual manual cranks. Out riggers while in the stowed position shall not extend beyond the outer most edge of the body and a minimum of 12" above level ground.
- Tread plate bumper shall be 15" deep with reinforced recess with a hinged bumper cover for receiver hitch access.

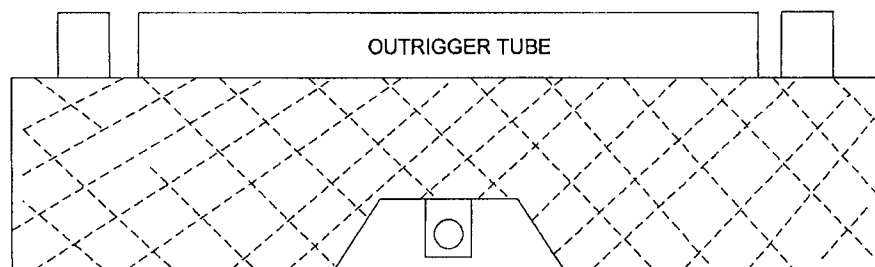

BUMPER DOWN VIEW

Lighting:

- Lighting to meet all FMVSS standards. Wiring harness to be encased in plastic loom, and all wires colored for ease of troubleshooting. Wire harness must have connectors compatible with Ford, GM, and Dodge chassis without splicing. LED stop, tail, turn, backup lights and amber LED flashing lights shall be mounted in shock-proof, rubber recessed, horizontally high mounted. Stop, tail, and turn lights to be clear back style with amber LED flashing light. License plate bracket and light shall be mounted directly below the amber LED flashing light on the roadside rear body panel at a height as to be visible when a 5 gallon water keg is in place. Identification lamp shall be LED mounted directly below the tailgate. LED side-marker lights are to be recessed in body drip rail for protection. Backup alarm shall be mounted directly below the amber LED flashing light on the curbside. The front amber LED flashing lights shall be mounted in the front grill. Both rear and front LED flashing lights shall be controlled from a single cab mounted switch.

Body and Compartment:

- Body Shell – 14 gauge two-sided A40 galvanized steel. Compartment top and back to be one piece seamless design. All doors, door openings, drop rails, and other exposed steel edges to be hemmed for strength, safety and resistance to corrosion.

Bid No: 15-28

- Floor – Minimum 12 gauge tread plate with 1 ¼” return flange on each side. Side compartment back panel overlaps and interlocks with floor flange, providing support for weight of side compartment. Six (6) flush mounted tie downs spaced three inches from compartment; three each side evenly spaced at 24” apart with first tie down 12” from rear of bed.
- Understructure – 50,000 yield 11 gauge high strength steel cross sills.
- Doors – 20 gauge two-sided A40 galvaneal steel double panel doors with hat section reinforcements.
- T-Handles or Rotary Latches – Zinc plated corrosion resistant rotary latches riveted to door with non-corrosive aluminum rivets incorporating stainless mandrels.
- Door Strikers on Rotary Latches – Adjustable security-ring striker affixed to door frame with screws. (Welded door strikers not acceptable).
- Door Seals – Automotive “bulb type” neoprene door seals to be installed by the manufacturer of the body on all door frames.
- Shelving – 18 gauge two-sided G-40 regular spangle galvanized rated to support up to 250 lb. loads.
- Exterior Prime Paint – Body is to be completely immersed in electro deposition gray epoxy prime paint featuring a zinc phosphate precoat and seal for additional corrosion protection. Prime paint is to be oven cured to provide a hard durable finish. Exterior paint color to match cab.
- Interior Paint – Interior paint to be mid-glass, mar resistant, light gray finish.
- Undercoating – Body to be completely undercoated by the manufacturer of the body using minimum five (5) mils of water base acrylic.
- Spray-on Bed Liner for Service Bodies – (Rhino or Line-X or SJC Fleet approved equivalent). Dealer must provide at vehicle delivery the warranty certificate. Protective coating shall be applied to the service-body floor (Minimum of ¼”), continuing vertical up the compartments, bulkhead, continuing over the top (horizontal surface) of the bulkhead and the entire length of both compartments continuing over the outside edge (1 ½” to 2”) and the rear and front of both compartments, including the tailgate, both sides. Protective coating shall be applied inside of both of the horizontal compartment doors to provide protection when in use as a work surface. Protective coating shall be applied to the entire inside surface of the tailgate continuing over the top and outside edge 1 ½” to 2”. Protective coating shall be applied to the rear bumper over both the vertical and horizontal surface.

Bid No: 15-28

TERMS: Net 30 Days

DELIVERY: F.O.B. St. Johns County Fleet Maintenance
2740 Industry Center Road
St. Augustine, FL 32084

All paperwork must be with vehicle at the time of delivery such as Certificate of Origin for a Vehicle (MSO), Florida Department of Highway Safety and Motor Vehicles Application for Certificate of Title with/without Registration, Invoice, Odometer Disclosure Statement, Temporary Tag, etc.

St. Johns County reserves the right to accept or reject any or all bids, waive minor formalities, and to award the bid that best serves the interests of St. Johns County. St. Johns County also reserves the right to award the base bid and any option items in any combination that best suits the needs of the County.