

RESOLUTION NO. 2016-71

A RESOLUTION BY THE BOARD OF COUNTY COMMISSIONERS OF ST. JOHNS COUNTY, FLORIDA, AUTHORIZING EXECUTION OF A RAILROAD REIMBURSEMENT AGREEMENT FOR THE INSTALLATION OF GRADE CROSSING TRAFFIC CONTROL DEVICES, AND FUTURE MAINTENANCE AND ADJUSTMENT OF SAID DEVICES; PROVIDING FOR THE EXPENDITURE OF FUNDS; AND AUTHORIZING THE CHAIR OF THE ST. JOHNS COUNTY COMMISSION TO EXECUTE THE AGREEMENT ON BEHALF OF THE COUNTY

WHEREAS, the State of Florida Department of Transportation is changing a portion of the Public Road System on 5th Street (off US1 North) which shall call for the installation and maintenance of railroad grade crossing traffic control devices for railroad grade crossing over or near said highway; and

WHEREAS, St. Johns County desires to enter into a Railroad Reimbursement Agreement with the State of Florida Department of Transportation and the Florida East Coast Railway Company (Company) for the installation and maintenance of certain grade crossing traffic control devices designated as Financial Number 432879-1-57-01 on 5th Street which crosses the right of way and tracks of the Company at FDOT/AAR Crossing No. 271838E located near St. Augustine, and

WHEREAS, the County shall assume its share of the costs for future maintenance and adjustment of said grade crossing control devices as designated in the Railroad Reimbursement Agreement.

WHEREAS, entering into the Railroad Reimbursement Agreement serves a public purpose.

NOW, THEREFORE, BE IT RESOLVED BY THE BOARD OF COUNTY COMMISSIONERS OF ST. JOHNS COUNTY, FLORIDA, AS FOLLOWS:

Section 1. The above Recitals are hereby incorporated into the body of this Resolution, and are adopted as Findings of Fact.

Section 2. The Board of County Commissioners hereby approves the attached and incorporated Railroad Reimbursement Agreement between the Board of County Commissioners of St. Johns County, the State of Florida Department of Transportation and the Florida East Coast Railway Company and authorizes the Chair to execute the Agreement on behalf of the County.

Section 3. To the extent that there are typographical and/or administrative errors that do not change the tone, tenor, or concept of this Resolution may be revised without subsequent approval of the Board of County Commissioners.

PASSED AND ADOPTED by the Board of County Commissioners of St. Johns County, Florida this 15th day of March 2016.

**BOARD OF COUNTY COMMISSIONERS
OF ST. JOHNS COUNTY, FLORIDA**

BY: Jeb S. Smith
Jeb S. Smith, Chair

ATTEST: Hunter S. Conrad

Hunter S. Conrad
Deputy Clerk

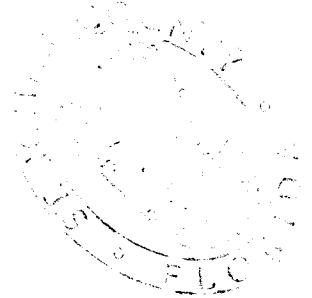

RENDITION DATE 3/17/16

STATE OF FLORIDA DEPARTMENT OF TRANSPORTATION
RAILROAD REIMBURSEMENT AGREEMENT
GRADE CROSSING TRAFFIC CONTROL DEVICES - COUNTY

FINANCIAL PROJECT NO.	ROAD NAME OR NUMBER	COUNTY NAME	PARCEL & R/W NUMBER	FAP NUMBER
43287915701	5th St at SR 5 (US 1)	ST. JOHNS	1(SIG-W)	RHH-00S2-054J

THIS AGREEMENT, made and entered into this _____ day of _____, _____, by and between the STATE OF FLORIDA DEPARTMENT OF TRANSPORTATION, hereinafter called the DEPARTMENT, and Florida East Coast Railway, LLC, a corporation organized and existing under the laws of Florida with its principal place of business in the City of Jacksonville, County of Duval State of Florida, hereinafter called the COMPANY; and St. Johns County, a political subdivision of the State of Florida, acting by and through its Board of County Commissioners, hereinafter called the COUNTY.

WITNESSETH:

WHEREAS, the DEPARTMENT is constructing, reconstructing or otherwise changing a portion of the Public Road System, designated by the Financial Project ID 43287915701 on 5th St at SR 5 (US 1), which crosses at grade the right of way and tracks of the COMPANY'S Milepost 32.51, FDOT/AAR Crossing Number 271838E, at or near St. Augustine, Florida as shown on DEPARTMENT'S Plan Sheet No. N/A, attached hereto as a part hereof; and

NOW, THEREFORE, in consideration of the mutual undertakings as herein set forth, the parties hereto agree as follows:

1. The COMPANY shall furnish the necessary materials and install Automatic Grade Crossing Signals Type III Class IV and/or other traffic control devices at said location on an actual cost basis and in accordance with (1) the attached detailed statement of the work, plans, and specifications; and (2) the DEPARTMENT'S Plans and Standard Index Number 17882 attached hereto and made a part hereof.
2. After installation of said signals is completed, one hundred (100%) percent of the expense thereof in maintaining the same shall be borne by the COUNTY, as enumerated by the Schedule of Annual Cost of Automatic Highway Grade Crossing Devices attached hereto and by this reference made a part hereof and subject to future revision.
3. After said signals have been installed and found to be in satisfactory working order by the parties hereto, the same shall be immediately put into service, operated and maintained by the COMPANY so long as said COMPANY or its successors or assigns shall operate the said signals at said grade crossing; or until it is agreed between the parties hereto that the signals are no longer necessary or until the said crossing is abandoned; or legal requirements occur which shall cease operation of signals thereat.

The COMPANY agrees that any future relocation or adjustment of said signals shall be performed by the COMPANY, but at the expense of the party initiating such relocation. Upon relocation the maintenance responsibilities shall be in accordance with the provisions of this agreement. It is further agreed that the cost of maintaining any additional or replacement signal equipment at the same location will be shared as provided under Paragraph 2. above.

4. Unless otherwise agreed upon herein, the COUNTY agrees to ensure that at the crossing the advance warning signs and railroad crossing pavement markings will conform to the U.S. Department of Transportation Manual on Uniform Traffic Control Devices within 30 days of notification that the railroad signal improvements have been completed and that such signs and pavement markings will be continually maintained at an acceptable level.

5. The COMPANY hereby agrees to install and/or adjust the necessary parts of its facilities along said road in accordance with the provisions set forth in the:

- (a) DEPARTMENT Procedure No. 725-080-002 Appendix D.4, and Rule 14.57.011 "Public Railroad-Highway Grade Crossing Costs", Florida Administrative Code.
- (b) Federal Highway Administration Federal-Aid Policy Guide, 23 C.F.R. Subchapter G, Part 646, Subpart B, and 23 C.F.R., Subchapter B, Part 140, Subpart I,

and any supplements thereto or revisions thereof, which, by reference hereto, are made a part hereof. The COMPANY further agrees to do all of such work, with its own forces or by a contractor paid under a contract let by the COMPANY, all under the supervision and approval of the DEPARTMENT and the Federal Highway Administration, when applicable.

6. The DEPARTMENT hereby agrees to reimburse the COMPANY for all costs incurred by it in the installation and/or adjustment of said facilities, in accordance with the provisions of Procedure No. 725-080-002 Appendix D-4 "Billing Requirements," and any supplements thereto or revisions thereof. It is understood and agreed by and between the parties hereto that preliminary engineering costs not incorporated within this agreement shall not be subject to payment by the DEPARTMENT.

7. Attached hereto, and by this reference made a part hereof, are plans and specifications of the work to be performed by the COMPANY pursuant to the terms hereof, and an itemized estimate of the cost thereof in the amount of \$ 314,600.00. All work performed by the COMPANY pursuant hereto, shall be performed according to these plans and specifications as approved by the DEPARTMENT and the Federal Highway Administration if federal aid participating; and all subsequent plan changes shall likewise be approved by the DEPARTMENT and the Federal Highway Administration, when applicable.

8. All labor, services, materials, and equipment furnished by the COMPANY in carrying out the work to be performed hereunder shall be billed by the COMPANY direct to the DEPARTMENT. Separate records as to the costs of

contract bid items and force account items performed for the COMPANY shall also be furnished by the COMPANY to the DEPARTMENT.

9. The COMPANY has determined that the method to be used in developing the relocation or installation cost shall be as specified for the method checked and described hereafter:

- (a) Actual and related indirect costs accumulated in accordance with a work order accounting procedure prescribed by the applicable Federal or State regulatory body.
- (b) Actual and related indirect costs accumulated in accordance with an established accounting procedure developed by the COMPANY and approved by the DEPARTMENT.
- (c) An agreed lump sum \$ _____, as supported by a detail analysis of estimated cost attached hereto. (NOTE: This method is not applicable where the estimated cost of the proposed adjustment exceeds \$100,000.)

10. The installation and/or adjustment of the COMPANY'S facility as planned will will not involve additional work over and above the minimum reimbursable requirements of the DEPARTMENT. (If upgrading and/or nonreimbursable work is involved at the option of the COMPANY, then credit against the cost of the project is required and will be governed by the method checked and described hereafter):

- (a) _____ % will be applied to the final billing of work actually accomplished to determine required credit for (betterment) and/or (expired service life) and/or (nonreimbursable segments).
- (b) All work involving nonreimbursable segments will be performed by special COMPANY work or job order number apart and separate from the reimbursable portion of the work; such work or job order number to be _____. The COMPANY further agrees to clearly identify such additional work areas in the COMPANY'S plans and estimates for the total work covered by this Agreement.
- (c) \$ _____ credited for betterment expired service life
 nonreimbursable segments in accord with Article 9.(c) hereinabove.

11. It is specifically agreed by and between the DEPARTMENT and the COMPANY that the DEPARTMENT shall receive fair and adequate credit for any salvage which shall accrue to the COMPANY as a result of the above installation and/or adjustment work.

12. It is further agreed that the cost of all improvements made during this adjustment work shall be borne by the COMPANY, subject only to the DEPARTMENT bearing such portion of this cost as represents the cost of adjustment of previously existing facility, less salvage credit as set forth in the immediately preceding paragraph.

13. Upon completion of the work the COMPANY shall, within one hundred eighty (180) days, furnish the DEPARTMENT with two (2) copies of its final and complete billing of all costs incurred in connection with the work performed hereunder, such statement to follow as closely as possible the order of the items contained in the estimate attached hereto. The totals for labor, overhead, travel expense, transportation, equipment, material and supplies, handling costs and other services shall be shown in such a manner as will permit ready comparison with the approved plans and estimates. Materials shall be itemized where they represent major components of cost in the relocation following the pattern set out in the approved estimate as closely as is possible. Salvage credits from recovered and replaced permanent and recovered temporary materials shall be reported in said bills in relative position with the charge for the replacement or the original charge for temporary use.

The final billing shall show the description and site of the Project; the date on which the first work was performed, or, if preliminary engineering or right-of-way items are involved, the date on which the earliest item of billed expense was incurred; the date on which the last work was performed or the last item of billed expense was incurred; and the location where the records and accounts billed can be audited. Adequate reference shall be made in the billing to the COMPANY'S records, accounts and other relevant documents. All cost records and accounts shall be subject to audit by a representative of the DEPARTMENT. Upon receipt of invoices, prepared in accordance with the provisions of the above indicated Reimbursement Policy, the DEPARTMENT agrees to reimburse the COMPANY in the amount of such actual costs as approved by the DEPARTMENT'S auditor.

14. Payment shall be made only after receipt and approval of goods and services unless advance payments are authorized by the DEPARTMENT's Comptroller under Section 334.044(29), F.S., or by the Department of Financial Services under Section 215.422(14), Florida Statutes (F.S.).

15. In accordance with Section 287.058, Florida Statutes, the following provisions are in this Agreement: If this Contract involves units of deliverables, then such units must be received and accepted in writing by the Contract Manager prior to payments. Bills for fees or other compensation for services or expenses shall be submitted in detail sufficient for a proper preaudit and postaudit thereof.

16. Bills for travel expenses specifically authorized in this agreement shall be submitted and paid in accordance with DEPARTMENT Rule 14-57.011 "Public Railroad-Highway Grade Crossing Costs" and the Federal Highway Administration Federal-Aid Policy Guide, Subchapter B, Part 140, Subpart I "Reimbursement for Railroad Work."

17. In accordance with Section 215.422, Florida Statutes, the following provisions are in this Agreement: Contractors providing goods and services to the Department should be aware of the following time frames. Upon receipt, the Department has five (5) working days to inspect and approve the goods and services, unless the Agreement specifies otherwise. The Department has 20 days to deliver a request for payment (voucher) to the Department of Financial Services. The 20 days are measured from the latter of the date the invoice is received or the goods or services are received, inspected and approved.

If a payment is not available within 40 days, a separate interest penalty at a rate as established pursuant to Section 215.422(3)(b), Florida Statutes, will be due and payable, in addition to the invoice amount, to the Contractor. Interest penalties of less than one (1) dollar will not be enforced unless the Contractor requests payment. Invoices which have to be returned to a Contractor because of Contractor preparation errors will result in a delay in the payment. The invoice payment requirements do not start until a properly completed invoice is provided to the Department.

A Vendor Ombudsman has been established within the Department of Financial Services. The duties of this individual include acting as an advocate for contractors/vendors who may be experiencing problems in obtaining timely payment(s) from a state agency. The Vendor Ombudsman may be contacted at (850) 413-5516 or by calling the Division of Consumer Services at 1-877-693-5236.

18. In the event this contract is for services in excess of TWENTY FIVE THOUSAND DOLLARS (\$25,000.00) and a term for a period of more than one year, the provisions of Section 339.135(6)(a), Florida Statutes, are hereby incorporated:

The Department, during any fiscal year, shall not expend money, incur any liability, or enter into any contract which, by its terms, involves the expenditure of money in excess of the amounts budgeted as available for expenditure during such fiscal year. Any contract, verbal or written, made in violation of this subsection is null and void, and no money may be paid on such contract. The Department shall require a statement from the Comptroller of the Department that such funds are available prior to entering into any such contract or other binding commitment of funds. Nothing herein contained shall prevent the making of contracts for periods exceeding one year, but any contract so made shall be executory only for the value of the services to be rendered or agreed to be paid for in succeeding fiscal years; and this paragraph shall be incorporated verbatim in all contracts of the Department which are for an amount in excess of TWENTY FIVE THOUSAND DOLLARS (\$25,000.00) and which have a term for a period of more than one year.

19. In accordance with Section 287.133 (2)(a), Florida Statutes, the following provisions are included in this Agreement:

A person or affiliate who has been placed on the convicted vendor list following a conviction for a public entity crime may not submit a bid, proposal, or reply on a contract to provide any goods or services to a public entity; may not submit a bid, proposal, or reply on a contract with a public entity for the construction or repair of a public building or public work; may not submit bids, proposals, or replies on leases of real property to a public entity; may not be awarded or perform work as a contractor, supplier, subcontractor, or consultant under a contract with any public entity; and may not transact business with any public entity in excess of the threshold amount provided in s.287.017 for CATEGORY TWO for a period of 36 months following the date of being placed on the convicted vendor list.

20. In accordance with Section 287.134(2)(a), Florida Statutes, the following provisions are included in this Agreement:

An entity or affiliate who has been placed on the discriminatory vendor list may not submit a bid, proposal, or reply on a contract to provide any goods or services to a public entity; may not submit a bid, proposal, or reply on a contract with a public entity for the construction or repair of a public building or public work; may not submit bids, proposals, or replies on leases of real property to a public entity; may not be awarded or perform work as a contractor, supplier, subcontractor, or consultant under a contract with any public entity; and may not transact business with any public entity.

21. In accordance with Section 287.0582, Florida Statutes, the following provision is included in this Agreement:

The Department's obligation to pay under this contract is contingent upon an annual appropriation by the Florida Legislature.

22. ~~The COMPANY covenants and agrees that it will indemnify and hold harmless the DEPARTMENT and all of the DEPARTMENT'S officers, agents, and employees from any claim, loss, damage, cost charge, or expense arising out of any act, action, neglect, omission or delay by the COMPANY during the performance of the contract,~~

~~whether direct or indirect, and whether to any person or property to which the DEPARTMENT or said parties may be subject, except that neither the COMPANY nor any of its sub-contractors will be liable under this section for damages arising out of injury or damage to persons or property directly caused or resulting from the sole negligence of the DEPARTMENT or any of its officers, agents, or employees.~~

FEC: _____
EDOT: _____
County: _____

23. COMPANY shall:

1. utilize the U.S. Department of Homeland Security's E-Verify system to verify the employment eligibility of all new employees hired by the COMPANY during the term of the contract; and
2. expressly require any subcontractors performing work or providing services pursuant to the state contract to likewise utilize the U.S. Department of Homeland Security's E-Verify system to verify the employment eligibility of all new employees hired by the subcontractor during the contract term.

24. It is understood and agreed by the parties to this Agreement that if any part, term, or provision of this Agreement is held illegal by the courts or in conflict with any law of the State of Florida, the validity of the remaining portions or provisions shall not be affected, and the rights and obligations of the parties shall be construed and enforced as if the Agreement did not contain the particular part, term, or provision held to be invalid.

25. Any questions or matters arising under this Agreement as to validity, construction, enforcement, performance, or otherwise, shall be determined in accordance with the laws of the State of Florida. Venue for any action arising out of or in any way related to this Agreement shall lie exclusively in a state court of appropriate jurisdiction in Leon County, Florida.

26. The parties agree to bear their own attorney's fees and costs with respect to this Agreement.

27. The parties agree that this Agreement is binding on the parties, their heirs-at-law, and their assigns and successors in interest as evidenced by their signatures and lawful executions below.

28. A modification or waiver of any of the provisions of this Agreement shall be effective only if made in writing and executed with the same formality as this Agreement.

29. Paragraph 22 has been stricken prior to execution by all parties at the request of Florida East Coast Railway, LLC.

IN WITNESS WHEREOF, the parties hereto have caused these presents to be executed by their duly authorized officers, the day and year first above written.

STATE OF FLORIDA
DEPARTMENT OF TRANSPORTATION

BY: _____
(TITLE: Greg Evans, District Two Secretary)

COMPANY: Florida East Coast Railway, LLC

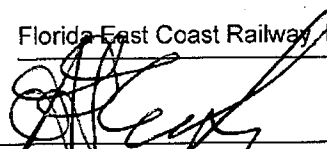
BY: 

A. G. Fowler, Jr. (Chief Engineer - Signals and Communications)

St. Johns COUNTY, FLORIDA

BY: _____
(TITLE: Chairman, Board of County Commissioners)

Legal Review

Approved as to Funds
Available

Approved as to FAPG
Requirements

BY: _____
Attorney - DOT Date

BY: _____
Comptroller - DOT Date

BY: Exempt
FHWA Date

STATE OF FLORIDA DEPARTMENT OF TRANSPORTATION
**RAILROAD GRADE CROSSING TRAFFIC CONTROL DEVICES
 ANNUAL MAINTENANCE COSTS**

725-090-41
 RAIL
 OGC - 03/12

FINANCIAL PROJECT NO.	ROAD NAME OR NUMBER	COUNTY NAME	PARCEL & R/W NUMBER	FAP NUMBER
43287915701	5th St at SR 5 (US 1)	ST. JOHNS	1(SIG-W)	RHH-00S2-054J

COMPANY NAME: Florida East Coast Railway, LLC

A. FDOT/AAR XING NO.: 271838E RR MILE POST TIE: 32.51

B. TYPE SIGNALS PROPOSED III CLASS IV DOT INDEX: 17882

**SCHEDULE OF ANNUAL COST OF AUTOMATIC
 HIGHWAY GRADE CROSSING TRAFFIC CONTROL DEVICES**

Annual Maintenance Cost Exclusive of Installation

<u>CLASS</u>	<u>DESCRIPTION</u>	<u>COST*</u>
I	Flashing Signals - One Track	\$2,256.00
II	Flashing Signals - Multiple Tracks	\$2,985.00
III	Flashing Signals and Gates - One Track	\$3,402.00
IV	Flashing Signals and Gates - Multiple Tracks	\$4,272.00
V	3 or 4 Quadrant Flashing Signals and Gates - One Track	\$6,726.00
VI	3 or 4 Quadrant Flashing Signals and Gates - Multiple Tracks	\$8,442.00

AUTHORITY: FLORIDA ADMINISTRATIVE RULE 14-57.011
 Public Railroad-Highway Grade Crossing Costs

EFFECTIVE DATE: July 22, 1982

GENERAL AUTHORITY: 334.044, F.S.

SPECIFIC LAW IMPLEMENTED: 335.141, F.S.

*This schedule will become effective July 1, 2011 and will be reviewed every 5 years and revised as appropriate based on the Consumer Price Index for all Urban Consumers published by the U.S. Department of Labor.

STATE OF FLORIDA DEPARTMENT OF TRANSPORTATION
WORK DESCRIPTION
GRADE CROSSING TRAFFIC CONTROL DEVICES

725-090-09
 RAIL
 05/02

FINANCIAL PROJECT NO.	ROAD NAME OR NUMBER	COUNTY NAME	PARCEL & R/W NUMBER	FAP NUMBER
43287915701	5th St at SR 5 (US 1)	ST. JOHNS	1(SIG-W)	RHH-00S2-054J

RAILROAD COMPANY

Florida East Coast Railway, LLC

- A. JOB DESCRIPTION & LOCATION: Signal upgrade at 5th St at SR 5 (US 1) in St Augustine
- B. TYPE OF ROADWAY FACILITY: Two lane undivided
- C. FDOT/AAR XING NO.: 32.51 RR MILE POST TIE: 271838E
- D. TYPE CROSSING PROPOSED: III CLASS: IV DOT INDEX NO.: 17882
- E. STATUS AND PROPOSAL:
1. EXISTING DEVICES: (See Agreement dated _____)
- a. None-New Crossing.
 - b. Crossbuck and Disk.
 - c. Flashing Signals with Disk.
 - d. Flashing Signals with Cantilever.
 - e. Flashing Signals with Gates.
 - f. Flashing Signals with Cantilever and Gates.
2. PROPOSED DEVICES: (Safety Index Rating 1115)
- a. No revision required.
 - b. Crossbuck and Disk.
 - c. Flashing Signals and Disk.
 - d. Flashing Signals with Cantilever.
 - e. Flashing Signals with Gates.
 - f. Flashing Signals with Cantilever and Gates.
 - g. Relocate existing signal devices:
 - (1) (With-Without) addition of Gates.
 - (2) (With-Without) synchronization with highway traffic signals.
 - (3) (With-Without) constant warning time.
- F. COMMUNICATION AND/OR POWER LINE ADJUSTMENTS
- 1. N/A By Others (_____ Company.)
 - 2. By Railroad Company.
- G. AUTHORITY REQUESTED: (Draft attached: Yes No.)
- 1. Agreement (Third Party Participating St Johns County)
 - 2. Supplemental Agreement No. _____
 - 3. Crossing Permit. _____
 - 4. Estimate for Change Order No. _____
 - 5. Letter of Authority. _____
 - 6. Letter of Confirmation (No Cost to Department).
- H. OTHER REMARKS:

Negotiations to be completed by: December 2015
 Signal installation target date: _____
 Synchronization: (Draft attached Yes No.)



OFFICE OF THE ASSISTANT CHIEF ENGINEER
SIGNALS AND COMMUNICATIONS

2013 DIAGNOSTICS

DATE: 08/28/12
TYPE: 3
CLASS: 4
NO OF DAYS: 11
AAR / DOT #: 271838E
MILE POST: 32 + 2669'
Project Type: FDOT

ESTIMATED COST FOR HIGHWAY CROSSING WARNING DEVICES AT 5th STREET.
This estimate should be considered void after one (1) year

MATERIAL	UNIT COST	UNITS	TOTAL COST
GATE FOUNDATIONS	\$675.00	2 EA	\$1,350.00
GATE SAVER SADDLES	\$1,168.00	2 EA	\$2,336.00
BACK TO BACK LED FLASHING LIGHTS	\$2,000.00	3 SET	\$6,000.00
SIDE LIGHT EXTENSION BRACKET (FOR AVE A)	\$309.00	1 EA	\$309.00
6'X6' WIRED CASE, WITH HXP-3R2	\$58,260.00	1 EA	\$58,260.00
GENERATOR CASE W/ TRANSFER SWITCH	\$5,615.00	1 EA	\$5,615.00
BATTERY BOX	\$675.00	1 EA	\$675.00
BATTERIES, SAFT SPL250	\$250.00	30 EA	\$7,500.00
MISC. GROUND MATERIAL	\$2,127.00	1 PKG.	\$2,127.00
CONDUIT & DIRECTIONAL BORE	\$45.00	60 FT	\$2,700.00
CABLE	\$14,500.00	1 PKG	\$14,500.00
MISCELLANEOUS RELAY EQUIPMENT	\$1,120.00	1 PKG	\$1,120.00
POWER SERVICE	\$1,800.00	1 EA	\$1,800.00
MONITORING EQUIPMENT	\$10,725.00	1 PKG.	\$10,725.00
SANITATION & DISPOSAL	\$1,500.00	1 PKG.	\$1,500.00
FREIGHT & HANDLING			\$28,754.00
TAX @ 6.5%			\$7,476.00
TOTAL MATERIALS			\$152,747.00
EXCAVATING EQUIPMENT PER DAY	\$417.10	11 DAYS	\$4,588.10
EQUIPMENT RENTAL PER DAY	\$200.00	11 DAYS	\$2,200.00
FOREMAN'S TRUCK PER DAY	\$224.70	11 DAYS	\$2,471.70
GANG TRUCK PER DAY	\$647.30	11 DAYS	\$7,120.30
SUPERVISORS TRUCK PER DAY	\$142.60	11 DAYS	\$1,568.60
EQUIPMENT TOTAL			\$17,949.00
DESIGN ENGINEERING	\$7,500.00	1	\$7,500.00
CONTRACT ENGINEERING	\$12,650.00	1	\$12,650.00
CONSTRUCTION ENGINEERING INSPECTION	\$1,350.00	3 DAYS	\$4,050.00
ENGINEERING TOTAL			\$24,200.00
CONSTRUCTION SUPERVISION	\$375.00	11 DAYS	\$4,125.00
LABOR ADDITIVE			\$2,382.00
TOTAL SUPERVISION LABOR			\$6,507.00
LABOR PER DAY	\$1,392.40		\$15,316.00
NUMBER OF DAYS	11		
LABOR ADDITIVE			\$9,004.00
TOTAL GANG LABOR			\$24,320.00
GANG EXPENSES PER DAY	\$803.00		
NUMBER OF DAYS	11		
TOTAL GANG EXPENSES			\$8,833.00
ESTIMATED FLAGGING TOTAL	\$1,000.00	11 DAYS	\$11,000.00
SUB-TOTAL			\$245,556.00
CONTINGENCIES 5%			\$12,278.00
TOTAL			\$257,834.00

+ 10% inflation factor
\$314,600

ESTIMATE NOTES:
FEC TO PROVIDED OR REUSE GATE MECHANISMS AND MAST 2 SETS OF LED LIGHTS CONSIST OF 8 LIGHTS. 1 SET FOR AVE 'A'

Crossing No: 271838E		Roadway: 5TH ST		RR Street:		District: 2		County: St. Johns	
PUBLIC HWY		AT GRADE Commercial		City: St. Augustine		NEAR CITY		OPEN-TRACK ACTIVE	
Rank 2013:	1003	SR No.:		RR Company:	FEC	Date: 07/27/2012			
Rank 2012:	1115	CR No.:		Division Name:		Team Members: Andy Fowler (FEC), James Powell (FEC),			
Rank 2011:	1527	US No.:		Subdivision Name:	FLAGLER	Ron Yates (FRA), Karin Charron, Donna Whitney,			
		Latitude:	29.948700	Branch Name:	MAIN	Jennifer Graham, Henry Parrish, Scott Allbritton, Bryan Collins (County)			
		Longitude:	-81.340000	RR Milepost:	32.51				
Field Review Comments: Antiquated.									
Team Recommendations: 4 sets LEDs, HXP3R2, event recorder, cabinet, cable, gen case, batteries & box, 2 gate savers, sidelights on W gate for Ave A (2 way), 2 new foundations. RR to provide: Labor and Gate mechs.									
Local Government Improvements: Pavement markings on US-1.									
Highway Speed:	25	<input type="checkbox"/>		Train Speed Range:	5-60	<input type="checkbox"/>			
Crossing Angle:	60-90 DEG	<input type="checkbox"/>		Max Time Table Speed:	60	<input type="checkbox"/>			
AADT:	2073 (2008)	<input type="checkbox"/>		Day Thru/Switch:	8/0	<input type="checkbox"/>			
Percent Trucks:	1 (2009)	<input type="checkbox"/>		Night Thru/Switch:	8/0	<input type="checkbox"/>			
School Buses:	4 (2014)	<input type="checkbox"/>		Train Service: Freight		<input type="checkbox"/>			
Street Types:	Two-Way Street	<input type="checkbox"/>		Passenger Count/Day:	0	<input type="checkbox"/>			
Thru Lanes:	2	<input type="checkbox"/>		Train Count Date:	06/18/2012	<input type="checkbox"/>			
Aux Lanes:	0	<input type="checkbox"/>		Main Tracks:	2	<input type="checkbox"/>			
Hazmat Route?	YES	<input type="checkbox"/>		Other Tracks:		<input type="checkbox"/>			
Emergency Services Route?	YES	<input type="checkbox"/>				<input type="checkbox"/>			
Emergency Notification Signs:	NO	<input type="checkbox"/>		Train Signals?	YES	<input type="checkbox"/>			
Crossbuck(4x4 post):	0	<input type="checkbox"/>		Train Signal Proximity:	YES	<input type="checkbox"/>			
Crossbuck Sign:	2	<input type="checkbox"/>		Train Detection:	Motion Detection	<input type="checkbox"/>			
Stop Sign:	0	<input type="checkbox"/>		Event Recorder?		<input type="checkbox"/>			
Yield Sign:	0	<input type="checkbox"/>		Number of Bells:	1	<input type="checkbox"/>			
Low Ground Clearance Signs:	0	<input type="checkbox"/>		Post Mounted Flashing Lights:	0	<input type="checkbox"/>			
Exempt Signs:	NO	<input type="checkbox"/>		Backlights, Incandescent		<input type="checkbox"/>			
Trespass Signs:	YES	<input type="checkbox"/>		Roadway Gate Count:	2	<input type="checkbox"/>			
W10-1	2	R10-6a	0	WB-1	0	<input type="checkbox"/>			
W10-2	0	R11-2	0	W10-8	0	<input type="checkbox"/>			
W10-3	2	R15-2P	2	W10-9	0	<input type="checkbox"/>			
W10-4	0	R15-6	0	W10-9P	0	<input type="checkbox"/>			
W10-11	0	R15-6a	0	W10-11a	0	<input type="checkbox"/>			
W10-12	0	R15-7	0	W10-11b	0	<input type="checkbox"/>			
R3-1a	0	R15-7a	0	W10-13P	0	<input type="checkbox"/>			
R3-2a	0	R15-8	0	W10-14P	0	<input type="checkbox"/>			
R8-8	0	Pvt Crossing	0	W10-14aP	0	<input type="checkbox"/>			
R8-9	0	Look Out	0	W10-15P	0	<input type="checkbox"/>			
R8-10	0	R8-8 w/Beacon	0	Slow	0	<input type="checkbox"/>			
R8-10a	0	W3-1		W10-1w/Beacon	0	<input type="checkbox"/>			
R10-6	0	W3-3		LED Signs	0	<input type="checkbox"/>			
Surface Installment Date:		<input type="checkbox"/>		Intersecting Roadway?	YES	<input type="checkbox"/>			
Surface Type:	CONCRETE	<input type="checkbox"/>		Signalized?	NO	<input type="checkbox"/>			
Pvmt Mrk:	STOPLINES AND XING SYMBOLS	<input type="checkbox"/>		Interconnection:	Not Interconnected	<input type="checkbox"/>			
Surface Condition:	EXCELLENT	<input type="checkbox"/>		Traffic Signals Controlling?	N	<input type="checkbox"/>			
Approach:	LOS A = Smooth	<input type="checkbox"/>		Preemption:		<input type="checkbox"/>			
Vehicle Reaction:	LOS B = Vibrating	<input type="checkbox"/>		Traffic Pre-Signals?	NO	<input type="checkbox"/>			
Driver Reaction:	LOS A = No reaction	<input type="checkbox"/>		8" Count:	0	<input type="checkbox"/>			
Rail/Pad Movement:	LOS A = Smooth	<input type="checkbox"/>		12" Count:	4	<input type="checkbox"/>			
Incident History:	09/1996	<input type="checkbox"/>		LED Count:	0	<input type="checkbox"/>			
		<input type="checkbox"/>		Install - Upgrade:	-- 03/21/1967	<input type="checkbox"/>			
		<input type="checkbox"/>		Maintenance Responsibility:	COUNTY	<input type="checkbox"/>			
		<input type="checkbox"/>		Roadway Paved:	YES	<input type="checkbox"/>			
		<input type="checkbox"/>		Tracks run down street?	NO	<input type="checkbox"/>			
		<input type="checkbox"/>		Sidewalks on Crossing Approach?	NO	<input type="checkbox"/>			
		<input type="checkbox"/>		Sidewalks Thru Crossing?	NO	<input type="checkbox"/>			
		<input type="checkbox"/>		Crossing illuminated?	NO	<input type="checkbox"/>			
		<input type="checkbox"/>		Commerical Power?	YES	<input type="checkbox"/>			
		<input type="checkbox"/>		Alternative Power?	NO	<input type="checkbox"/>			
Recommended Warning Device: FL & G									



FLORIDA DEPARTMENT OF TRANSPORTATION DISTRICT TWO RAIL LOCATION MAP

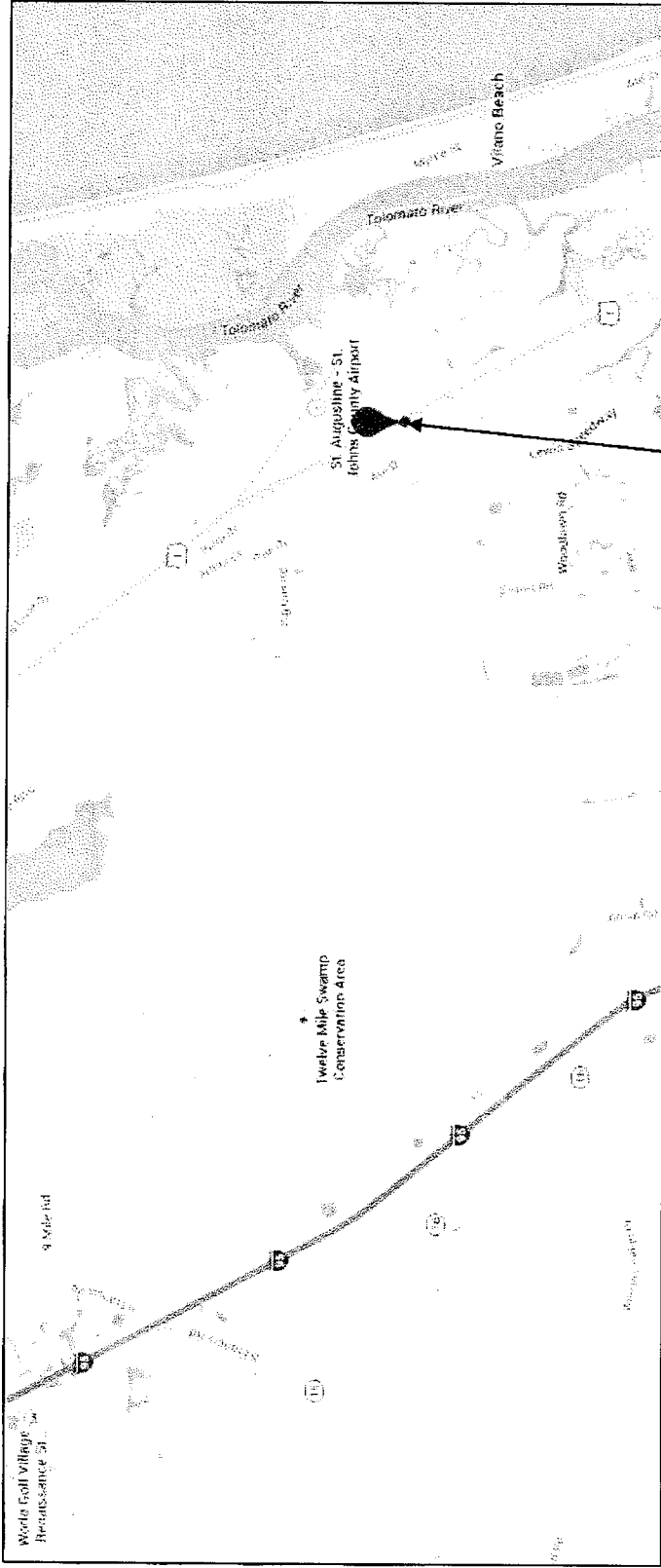

5th Street at SR 5 (US 1)
Crossing No. 271838E

St. Augustine, Florida

St. Johns County

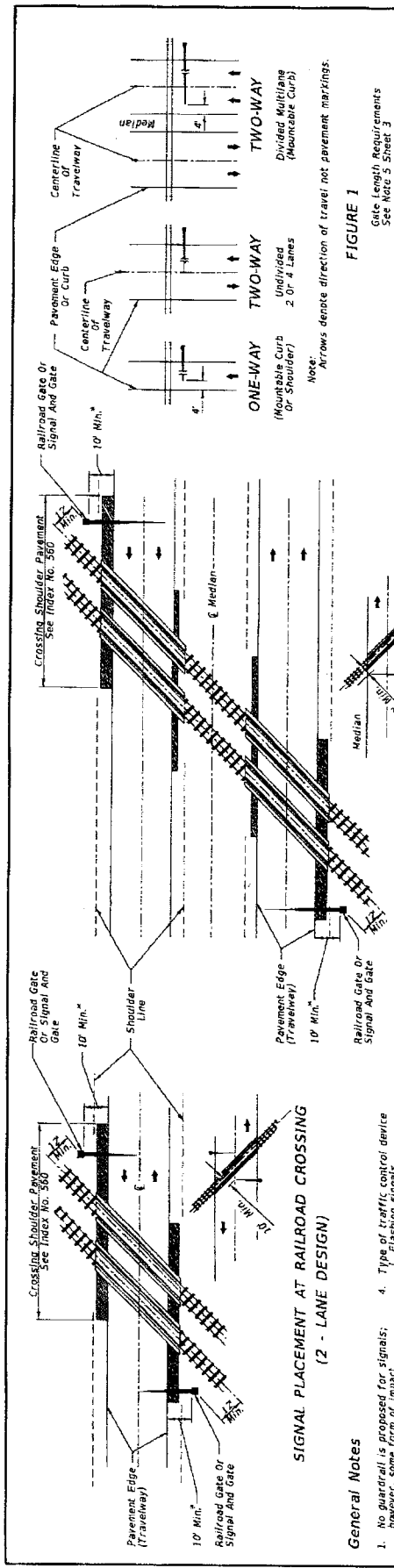
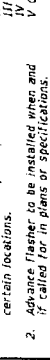

FIGURE 1
Gate Length Requirements
See Note 5 Sheet 3

SIGNAL PLACEMENT AT RAILROAD CROSSING
(4 - LANE DESIGN)



SIGNAL PLACEMENT AT RAILROAD CROSSING
(2 - LANE DESIGN)



General Notes

- No quadrant is proposed for signals; however, some form of impact attenuation device may be specified for certain locations.
- Advance flasher to be installed when and if called for in plans or specifications.
- Top of foundation shall be no higher than 4" above finished shoulder grade.
- Type of traffic control device:
 - Flashing signals with cantilever
 - Flashing signals with gate
 - Flashing signals with cantilever and gate
 - Gate
- Class of traffic control devices:
 - Flashing signals-multiple tracks
 - Flashing signals and gates-one track
 - Flashing signals and gates-multiple tracks

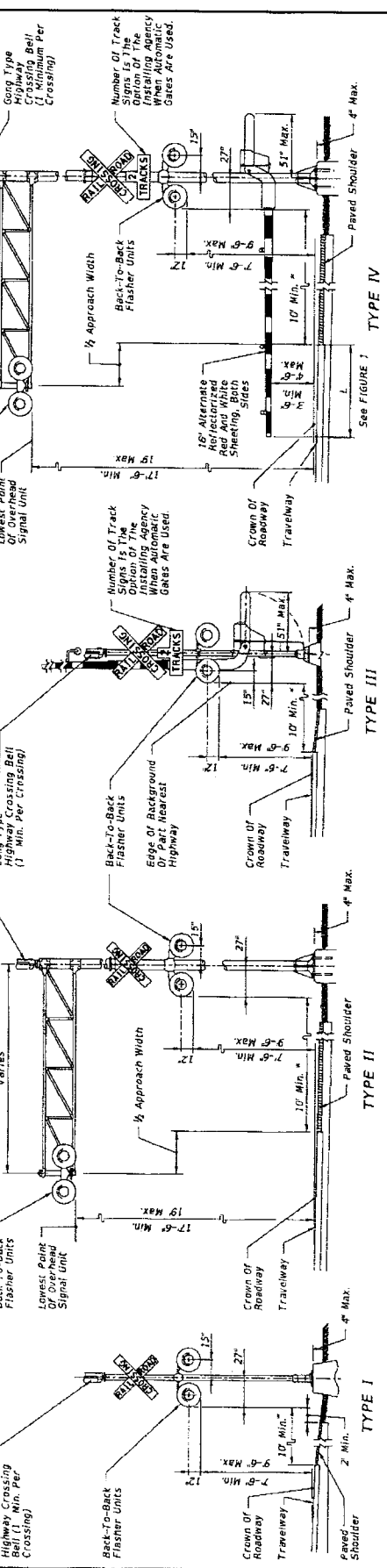

REVISION	DESCRIPTION:	INDEX NO.	SHEET NO.
07/01/13		17882	1 of 4
FDOT 2014 DESIGN STANDARDS		RAILROAD GRADE CROSSING TRAFFIC CONTROL DEVICES	

- GENERAL NOTES**
1. The location of flashing signals and stop lines shall be established based on future (or present) installation of gate with appropriate track clearances.
 2. Where plans call for railroad traffic control devices to be installed in curved medians, the minimum median width shall be 12'-6".
 3. Location of railroad traffic control device is based on the distance available between face of curb & sidewalk, 0' to 6". Locate device outside sidewalk. Over 6" - Locate device between face of curb and sidewalk.
 4. Stop line to be perpendicular to edge of roadway, approx. 15' from nearest rail, or 8' from and parallel to gate when present.
 5. When a cantilevered-arm flashing-light signal is used, the minimum vertical clearance shall be 17' from above the Crown of Roadway to the Lowest Point of the Overhead Signal Unit.

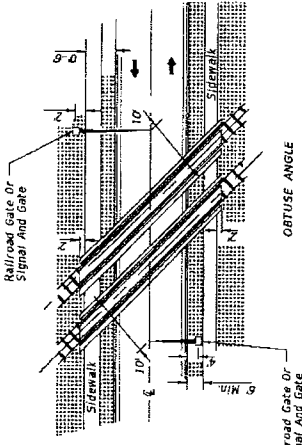

**SIGNAL PLACEMENT AT RAILROAD CROSSING
(2 LANES, CURB & GUTTER)**

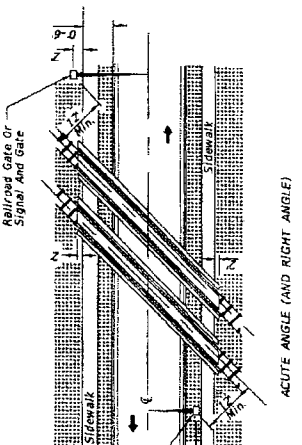

**SIGNAL PLACEMENT AT RAILROAD CROSSING
(2 LANES, CURB & GUTTER)**

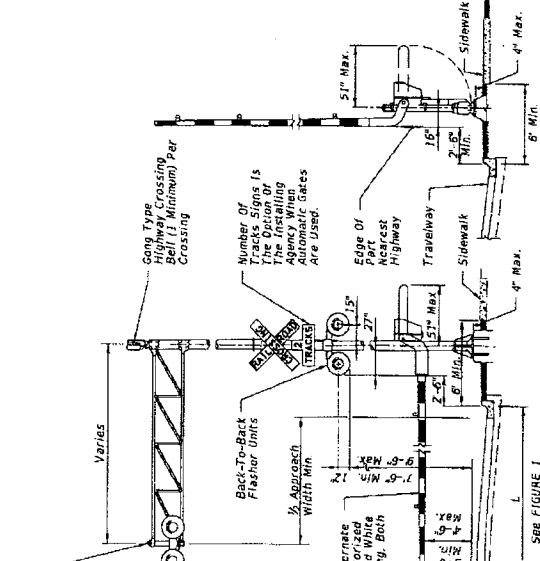

TYPE V

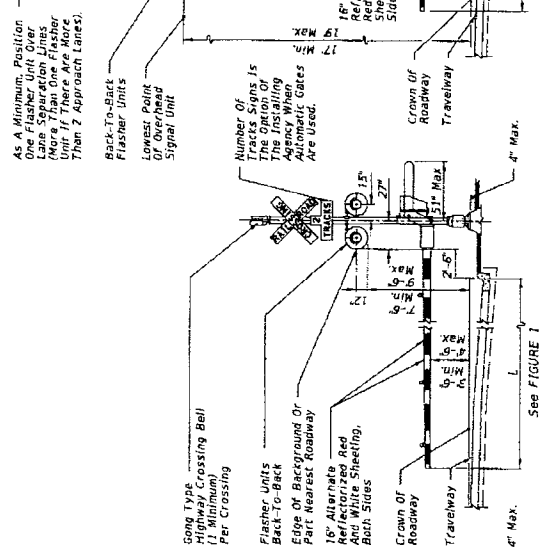

TYPE IV

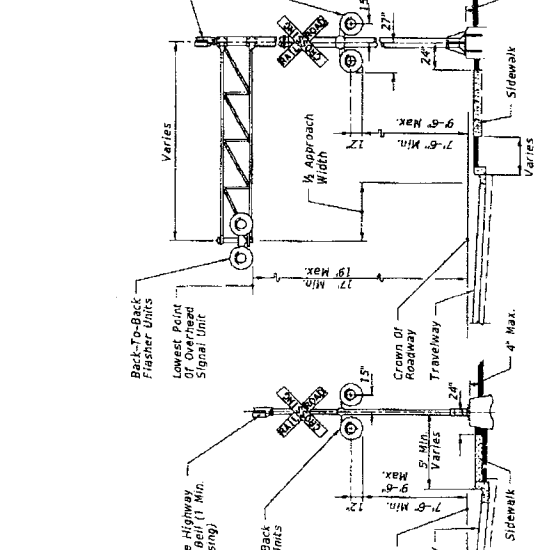

TYPE III

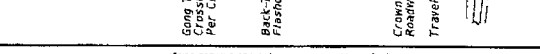

TYPE I

LAST REVISION 01/01/11	DESCRIPTION:	FDOT 2014 DESIGN STANDARDS	INDEX NO. 17882	SHEET NO. 2 of 4
---------------------------	--------------	-------------------------------	--------------------	---------------------



RAILROAD CROSSING AT TWO (2)-LANE ROADWAY

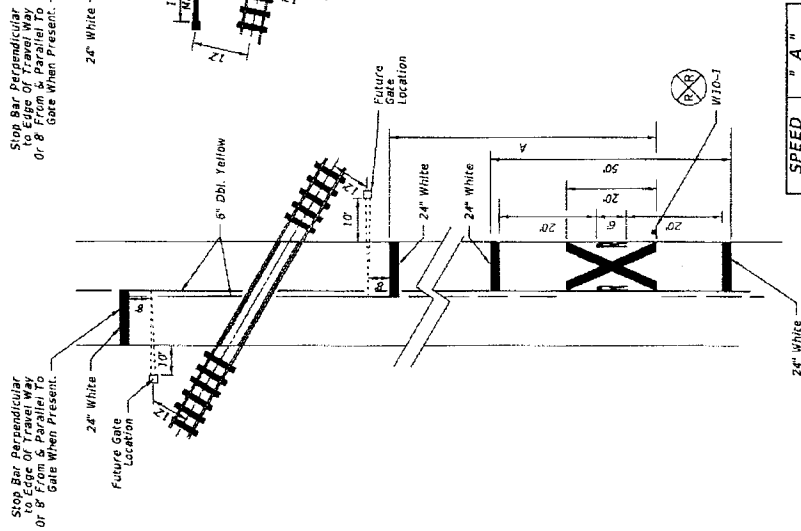

RAILROAD CROSSING AT MULTILANE ROADWAY

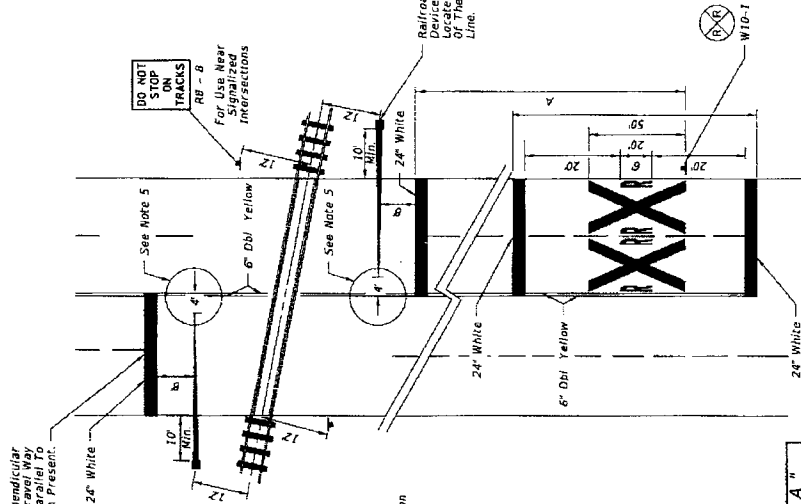

RELATIVE LOCATION OF CROSSING TRAFFIC CONTROL DEVICES

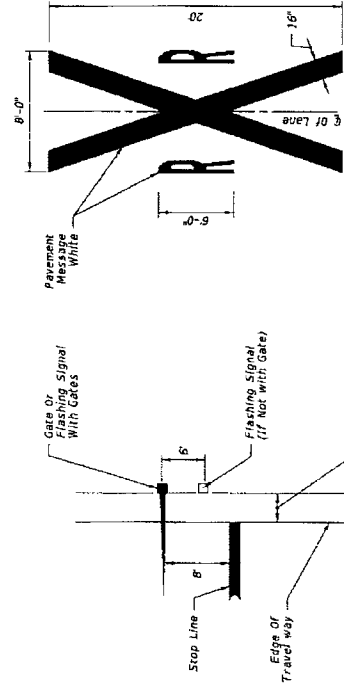

- NOTES:**
1. When computing pavement message quantities do not include traverse lines.
 2. Placement of sign W10-1 in a residential or business district, where the maximum gate length may not reach to a minimum distance of 100 feet from the crossing. Where street intersections occur between the RR pavement message and the tracks an additional W10-1 sign and additional pavement message should be used.
 3. A portion of the pavement markings symbol should be directly opposite the W10-1 sign.
 4. Recommended location for FTP-61-06 or FTP-62-06 signs, 100 urban and 300 rural. See Index 17355 for sign details.
 5. Gate Length Requirements: For two-way undivided sections: The gate should extend to within 1 foot of the center line. On multiple approaches the maximum gate length may not reach to within 1 foot of the center line. The gate length shall be a maximum of 4 feet. For one-way or divided sections: The gate length such that the distance from the gate lip to the inside edge of pavement is a maximum of 4 feet.

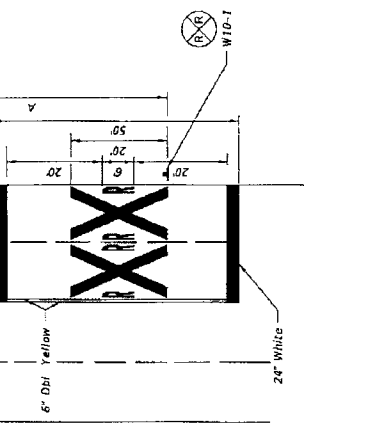

SPEED (mph)	A' (ft)	B' (ft)
60	400	
55	325	
50	250	
45	175	
40	125	
35	100	
URBAN	85 MIN.	

LAST REVISION 07/01/10

FDOT 2014 DESIGN STANDARDS



RAILROAD GRADE CROSSING TRAFFIC CONTROL DEVICES

INDEX NO. 17862 SHEET NO. 3 OF 4

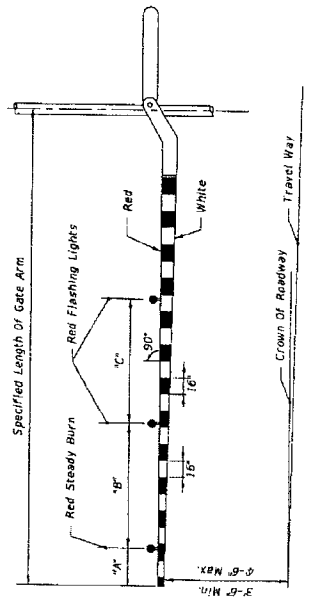

RAILROAD GATE ARM LIGHT SPACING

Specified Length Of Gate Arm	Dimension "A"	Dimension "B"	Dimension "C"
14 Ft.	6"	36"	5'
15 Ft.	18"	36"	5'
16-17 Ft.	24"	36"	5'
18-19 Ft.	28"	41"	5'
20-23 Ft.	28"	4'	5'
24-28 Ft.	28"	5'	5'
29-31 Ft.	36"	6'	6'
32-34 Ft.	36"	7'	7'
35-37 Ft.	36"	9'	9'
38 And Over	36"	10'	10'

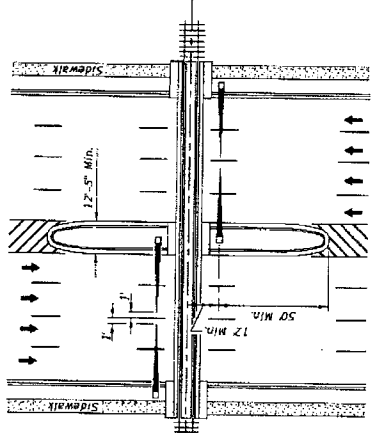

PLAN

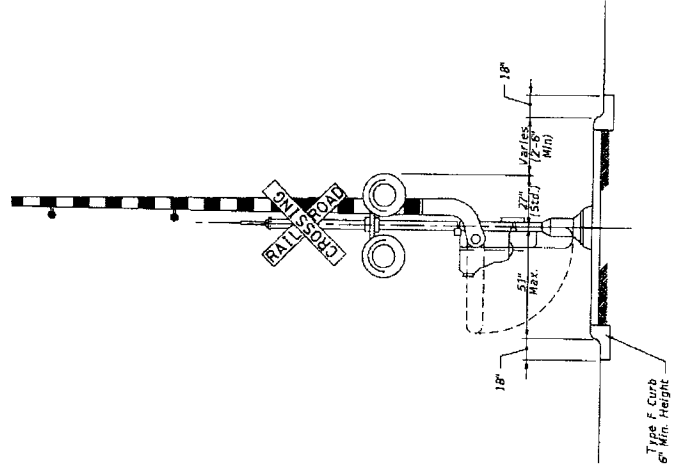

MEDIAN SECTION AT SIGNAL GATES

NOTE:
For additional information see the "Manual On Uniform Traffic Control Devices", Part 6; The "Traffic Control Handbook", Part VIII; and AASHTO "A Policy On Geometric Design Of Streets And Highways".

MEDIAN SIGNAL GATES FOR

MULTILANE UNDIVIDED URBAN SECTIONS

(THREE OR MORE DRIVING LANES IN ONE DIRECTION, 45 MPH OR LESS)

LAST REVISION 01/01/12



FDOT 2014 DESIGN STANDARDS

RAILROAD GRADE CROSSING TRAFFIC CONTROL DEVICES

INDEX NO. 17882

SHEET NO. 4 of 4