

RESOLUTION NO. 2018 - 35

A RESOLUTION BY THE BOARD OF COUNTY COMMISSIONERS OF ST. JOHNS COUNTY, FLORIDA, AUTHORIZING THE COUNTY ADMINISTRATOR, OR DESIGNEE, TO EXECUTE CONTRACT AMENDMENT #1 TO THE AGREEMENT FOR CONSTRUCTION OF THE PLAYERS CLUB WATER RECLAMATION FACILITY (BID NO. 17-63)

RECITALS

WHEREAS, the County entered into an agreement with Wharton Smith, Inc. for construction of the Players Club Reclamation Facility at a total contract price of \$32,778,000 (see attached); and

WHEREAS, following execution of the agreement, the St. Johns County Utilities Department (Department) value-engineered items such as concrete, coating, BNR wall modification and an alternate manhole liner in an effort to find available cost savings in completing the project; and

WHEREAS, the Department also identified certain equipment needed to complete the project, which as owner of the project, the County could purchase directly to result in additional savings in the form of sales tax; and

WHEREAS, the combined total savings identified by the Department resulting from value engineering and owner direct purchases is approximately \$852,443.85; and

WHEREAS, the County and Wharton Smith, Inc. seek to amend the agreement, reducing the contract price to achieve the savings described herein; and

WHEREAS, the County has reviewed the terms, provisions, conditions and requirements of the proposed contract amendment (attached hereto, an incorporated herein) and finds that entering into contract amendment #1 to complete the work serves a public purpose; and

WHEREAS, as the project proceeds, in the event that there are other opportunities for additional savings through owner direct purchases by the County, staff requests authority to make such purchases through change order to further reduce the contract price; and

NOW, THEREFORE BE IT RESOLVED BY THE BOARD OF COUNTY COMMISSIONERS OF ST. JOHNS COUNTY, FLORIDA, as follows:

Section 1. The above Recitals are incorporated by reference into the body of this Resolution and such Recitals are adopted as finds of fact.

Section 2. The County Administrator, or designee, is hereby authorized to execute a contract amendment in substantially the same form and format as attached hereto, providing for the reduction in contract price and respective modifications to the Scope of Work.

Section 3. The County Administrator, or designee, is further authorized to make additional owner direct purchases through change order for equipment necessary to complete the project, which will result in further reduction of the contract price.

Section 4. To the extent that there are typographical and/or administrative errors that do not change the tone, tenor, or concept of this Resolution, then this Resolution may be revised without subsequent approval by the Board of County Commissioners.

PASSED AND ADOPTED by the Board of County Commissioners of St. Johns County, Florida, this 6 day of February 2018.

**BOARD OF COUNTY COMMISSIONERS OF
ST. JOHNS COUNTY, FLORIDA**

By: 
Henry Dear, Chair

ATTEST, Hunter S. Conrad, Clerk
By: 
Deputy Clerk

RENDITION DATE 2/7/18

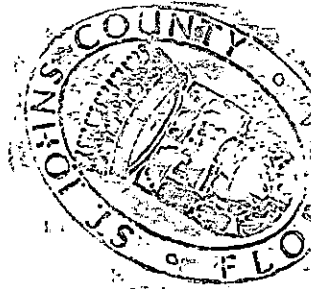

<u>Equipment List</u>	<u>Equipment Price</u>	<u>Tax</u>	<u>Taxed Value</u>	<u>Vendor</u>
UV System	\$ 766,924.53	\$ 46,040.47	\$ 812,965.00	Enaqua
BandScreen	\$ 200,000.00	\$ 12,025.00	\$ 212,025.00	Hydrodine
Clarifiers	\$ 428,074.00	\$ 25,709.44	\$ 453,783.44	Ovivo
Grit Removal Equipment	w/ above			Ovivo
WEMCO Pumps, Weirs and Baffles, Ford Hall Algae Sweep	\$ 193,076.00	\$ 11,609.56	\$ 204,685.56	TSC Jacobs
Turbo Blowers	\$ 460,867.00	\$ 27,677.02	\$ 488,544.02	Neuros
PD Blowers	\$ 144,338.00	\$ 8,685.28	\$ 153,023.28	Universal Blower Pak
VTP Pumps/Reuse Pumps	\$ 223,133.00	\$ 13,412.98	\$ 236,545.98	
Belt Filter Press	\$ 377,000.00	\$ 22,645.00	\$ 399,645.00	BDP
Conveyor/Polymer System	\$ 173,000.00	\$ 10,405.00	\$ 183,405.00	Keller-Angelillis
Odor Control	\$ 142,000.00	\$ 8,545.00	\$ 150,545.00	Biorem
RAS/WAS/IR Pumps/In Plant Pumps/Grinder PS/ Pre Anoxic Mixer/ Post Anoxic Mixer/Diffusers	\$ 669,997.00	\$ 40,224.82	\$ 710,221.82	Xylem
Scum Pumps/Belt Press Feed Pump	\$ 87,593.00	\$ 5,280.58	\$ 92,873.58	Penn Valley
Disk Filters	\$ 635,143.00	\$ 38,133.58	\$ 673,276.58	Aqua Aerboics
Chemical Feed	\$ 121,561.00	\$ 7,318.66	\$ 128,879.66	Trinova
Chemical Storage	\$ 50,914.00	\$ 3,079.84	\$ 53,993.84	Snyder
Generator and Fuel Tank	\$ 191,500.00	\$ 11,515.00	\$ 203,015.00	Catepillar
Hydro Pneumatic Tank	\$ 98,389.00	\$ 5,928.34	\$ 104,317.34	HydroAir
Slide Gates	\$ 70,138.00	\$ 4,233.28	\$ 74,371.28	RW Gates
Electrical Gear	\$ 499,000.00	\$ 29,965.00	\$ 528,965.00	Eaton
	Total Sales Tax	\$ 332,433.85		
	WS Administrative Fee	\$ 40,000.00		
	Subtotal	\$ 292,433.85		
	UV Allowance Credit	\$ 2,035.00		
	Band Screen	\$ (12,025.00)		
	Total Savings	\$ 282,443.85		

tax		surtax
\$46,015.47		25
12000		25
25684.44		25
		25
11584.56		25
27652.02		25
8660.28		25
13387.98		25
22620		25
10380		25
8520		25
40199.82		25
5255.58		25
38108.58		25
7293.66		25
3054.84		25
11490		25
5903.34		25
4208.28		25
29940		25

Players Club WRF - Value Engineering Cost Savings Items

No.	Item	Description	Savings
1	Modify use of Xypex in concrete	Eliminate Xypex in the floor/slabs of the BNR, secondary clarifiers, effluent pump station, and sludge holding tank.	\$ 90,000.00
2	Coatings modifications	Use of Tnemec coatings not as specified for use in the BNR and secondary clarifiers. All other coatings to remain as defined in the contract documents.	\$ 200,000.00
3	BNR wall modifications	Reductions in rebar of the BNR tank walls.	\$ 260,000.00
4	Direct Purchase of Equipment to Save 6.5% in Sales Tax	Large equipment cost estimates are approximately \$5.8 Million including the UV System, Clarifiers, Grit System, Dewatering System, Blowers, Pumps, and Electrical Gears.	\$ 282,443.85
5	Manhole Liners	Use HDPE liner instead of Raven/Spectrashield in manholes	\$20,000
Total			\$ 852,443.85

Owner Direct Purchases Equipment List	Equipment Supplier	Equipment Price	Sales Tax	Sur Tax	Freight	Site Services	Total Deduction of Wharton-Smith Contract
Disk Filters	Aqua-Aerobic Systems, Inc.	\$635,143.00	\$38,108.58	\$25.00	\$8,922.00	\$13,272.00	\$695,470.58
Odor Control System	Biorem Technologies	\$142,000.00	\$8,520.00	\$25.00	\$10,000.00	\$6,000.00	\$166,545.00
Vertical Turbine Pumps, End Suction Pumps	Carter & Verplanck, Inc.	\$223,133.00	\$13,387.98	\$25.00	Included	Included	\$236,545.98
Electrical Gear	Cogburn Bros. Electric, Inc.	\$514,000.00	\$30,840.00	\$25.00	Included	Included	\$544,865.00
UV Disinfection System	Enaqua	\$745,250.00	\$46,750.00	\$0.00	\$7,500.00	\$15,500.00	\$815,000.00
Turbo Blower	Neuros	\$460,867.00	\$27,652.02	\$25.00	Included	Included	\$488,544.02
Scum Pumps, Belt Press Feed pump, Clarifiers	Penn Valley Pump Co., Inc.	\$85,198.00	\$5,111.88	\$25.00	\$1,600.00	\$2,400.00	\$94,334.88
Grit Removal	Ovivo	\$220,706.00	\$13,242.36	\$25.00	\$30,735.00	Included	\$264,708.36
Slide Gates & Stop Logs	Ovivo	\$207,368.00	\$12,442.08	\$25.00	\$18,600.00	Included	\$238,435.08
Grit Pumps, Algare Brush System, Weirs and Baffles	RW Gate Company	\$70,138.00	\$4,208.28	\$25.00	\$5,700.00	Included	\$80,071.28
Postive Displacement Blowers	TSC-Jacobs North	\$193,076.00	\$11,584.56	\$25.00	Included	Included	\$204,685.56
RSA Pumps, WAS Pumps, Internal Recycle Propeller Pumps, In-plant Pumps, Grinder Pumps, Pre-anoxi Mixers, Post-anoxic Mixers	Universal BlowerPac	\$144,338.00	\$8,660.28	\$25.00	\$5,339.00	Included	\$158,362.28
Mechancial Bandscreen and Screenings Wash Press	Xylem Water Solutions USA Inc	\$669,997.00	\$40,199.82	\$25.00	Included	Included	\$710,221.82
Belt Filter Press System	HydroDyne Engineering	\$200,000.00	No Tax Added	\$0.00	Included	Included	\$200,000.00
	BDP Industries, Inc.	\$377,000.00	\$22,620.00	\$25.00	Included	Included	\$399,645.00
	Total	\$4,888,214.00	\$283,327.84	\$325.00	\$88,396.00	\$37,172.00	\$5,297,434.84
Future Owner Direct Purchases							
Conveyor System/Polymer System		\$170,000.00					
Chemical Feed		\$122,000.00					
Chemical Storage		\$50,000.00					
Generator and Fuel Tank		\$190,000.00					
Hydro Pneumatic Tank		\$98,000.00					
	Total	\$630,000.00					



AQUA-AEROBIC SYSTEMS, INC.
A Macomber Company

December 21, 2017

Correspondence ID#: AAL-37012
ALL BIDDING CONTRACTORS

Project: PLAYERS CLUB FL

RE: AASI Proposal # 145392-R1 dated December 21, 2017
AASI Project ID# 114409

Aqua-Aerobic Systems recently transmitted our proposal for the above referenced project. As requested, the following breakouts are provided in order to assist in determining the applicable taxes of the proposal.

Total Proposal Price: \$657,337
Freight Breakout: \$8,922 (non-taxable, per Aqua-Aerobic Systems' records)
Start-up Breakout: \$13,272 (taxable, per Aqua-Aerobic Systems' records)

Please let us know if you have any questions regarding our proposal.

**START-UP
SERVICES ARE
NON TAXABLE**

Sincerely,

Aaron Glauch
Project Applications Engineer

CC: EnviroSales of Florida, Inc. / ph#: 904-524-9576 / fx#: 863-314-0617

Joe Sacco / Joe@envirosalesofflorida.com

Aqua-Aerobic Systems, Inc.

Paul Nelson / PNelson@aqua-aerobic.com

**ODP PURCHASE ORDER NEEDS TO BE ISSUED
FOR FOLLOWING**

EQUIPMENT PRICE	- \$635,143
FREIGHT	- \$ 8,922
Site Services	- \$ 13,272
TOTAL	- \$657,337

DEDUCTION FROM WHARTON-SMITH

EQUIPMENT PRICE	- \$635,143.00
TAX	- \$ 38,108.58
SURTAX	- 25.00
FREIGHT	- \$ 8,922.00
Site Services	- \$ 13,272.00
TOTAL	- \$695,470.58

TOTAL TAX SAVING - \$38,133.58

Aeration & Mixing | Biological Processes | Filtration | Membranes | Process Control & Monitoring | Aftermarket Parts & Services

6306 N. Alpine Rd. Loves Park, IL 61111-7655 p 815.654.2501 f 815.654.2508 www.aqua-aerobic.com

BIOREM

December 21, 2017

To Whom it may concern

Biorem Environmental received a purchase order for the odor control system at the Players Club WWTP for a total value of \$158,000.

As part of that total, \$6,000 is allocated for startup services and engineering and \$10,000 is allocated as freight and shipping.

Please let me know if any additional information is needed.

Sincerely



Mike Harman
Sales Manager

**ODP PURCHASE ORDER NEEDS TO BE
ISSUED FOR FOLLOWING**

EQUIPMENT PRICE	- \$142,000
FREIGHT	- \$ 10,000
Site Services	- \$ 6,000
TOTAL	- \$158,000

DEDUCTION FROM WHARTON-SMITH

EQUIPMENT PRICE	- \$142,000
TAX	- \$ 8,520
SURTAX	- 25
FREIGHT	- \$ 10,000
Site Services	- \$ 6,000
TOTAL	- \$166,545

TOTAL TAX SAVING - \$8,545



CARTER VERPLANCK

4910 W CYPRESS ST.
TAMPA, FLORIDA 33607
www.carterverplanck.com

Phone: 813.287.0709

Fax: 813.282.8216

Quotation

To: Wharton-Smith
Attn: Matthew Peterson
Fax:

Date: 12/19/2017
Re: SJCUD – Players Club WRF
Section 11214 (VTPs) & 11650 (End Suction Pumps)

WE ARE PLEASED TO QUOTE YOU ON THE FOLLOWING MATERIAL FOR ACCEPTANCE WITHIN 30 DAYS

Section 11214 (Vertical Turbine Pumps)

A. Services

- ◆ Sawgrass: Two (2) model 12EMM-2 stage vertical turbine pumps with 40HP, 1800rpm, 460V, TEFC, VSS constant speed motors. Conditions of service: 720 gpm @ 150 ft
- ◆ TPC Stadium: Two (2) model 12ENH-1 stage vertical turbine pumps with 25HP, 1800rpm, 460V, TEFC, VSS constant speed motors. Conditions of service: 1,600 gpm @ 41 ft
- ◆ TPC Valley: Two (2) model 12ENH-3 stage vertical turbine pumps with 75HP, 1800rpm, 460V, TEFC, VSS constant speed motors. Conditions of service: 1,500 gpm @ 130 ft

B. Materials of Construction

- ◆ Cast Iron Bowls
- ◆ Bronze C958 impellers, keyed
- ◆ Bronze bowl bearings
- ◆ 416 SS pump shaft
- ◆ 316SS vortex suppressor
- ◆ 8", 10", 8" flanged carbon steel column pipe, schedule 40
- ◆ 1.0", 1.25", 1.25" 416 SS line shaft
- ◆ Rubber lineshaft bearings
- ◆ Cast iron bearing retainers
- ◆ 8", 10", 8" cast iron discharge head, 125# discharge flange
- ◆ Flanged spacer coupling
- ◆ Carbon steel baseplate
- ◆ Flowserve ISC2 mechanical seal
- ◆ All assembly hardware 316 SS
- ◆ Surface prep and pot-a-pox Tnemec N140 coating OD bowl assembly, OD/ID column, and OD/ID discharge head. Motor: Surface prep and coating per electrical industry standard

C. Testing

- ◆ Factory
 - a. Non-witness hydrostatic tests on the bowls, per latest HI Standards.
 - b. Non-witness factory complete assembly performance, performed with a calibrated shop test motor, per HI standards. Acceptance grade 1U.
 - c. Vibration readings
- ◆ Onsite
 - a. Vibration testing in X-Y profiles
 - b. Bump Tests
 - c. Noise Tests
 - d. 1 day for training
 - e. 2 days for installation and performance testing



CARTER VERPLANCK

4910 W CYPRESS ST.
TAMPA, FLORIDA 33607
www.carterverplanck.com

Phone: 813.287.0709

Fax: 813.282.8216

Quotation

To: Wharton-Smith
Attn: Matthew Peterson
Fax:

Date: 12/19/2017
Re: SJCUD – Players Club WRF
Section 11214 (VTPs) & 11650 (End Suction Pumps)

WE ARE PLEASED TO QUOTE YOU ON THE FOLLOWING MATERIAL FOR ACCEPTANCE WITHIN 30 DAYS

- D. Warranty for twenty-four (24) months from start-up, not to exceed thirty (30) months from shipment.
- E. Spare parts for each service
 - ◆ 1 collet hammer
 - ◆ 1 mechanical seal
- F. Freight (included)
 - ◆ Price includes all forgoing, CPT Ponte Vedra, FL
- G. Exclusions
 - ◆ Off-loading at jobsite, any labor or tools for Assembly or Installation, Field operation.
 - ◆ Suction or Discharge piping, mechanical couplings, supports, tie rods, leveling screws, fittings, etc.
 - ◆ Air relief valves / Vacuum valves / Isolation valves, etc.
 - ◆ Seal water or drain accessories such as piping, flow indicators, pressure reducing valves, Y strainers, fittings or tubing
 - ◆ Gauges, T cocks, anchor bolts, templates or accessories
 - ◆ VFDs or any type of Controls, Instrumentation, MCCs, Starters, Power Factor Correction Capacitors, Panels, cable, wiring, conduits, temperature or vibration probes, remote controls, or *any auxiliary electrical equipment extraneous to the pump motors*
 - ◆ Standard tools or tool chests, lubricants, grease fitting extensions or guns
 - ◆ Field painting, touch-up paint supply
 - ◆ Section 11214 1.10.A & 1.10.C: Exception must be taken to substantial completion, standard extended warranty was quoted: twenty-four (24) months from start-up, not to exceed thirty (30) months from shipment
 - ◆ Section 11214, 1.10: Quoted motor shall bear the standard limited warranty for motors of 36 months from installation/ 42 months from manufacture on sine wave power, whichever comes first.
 - ◆ Section 16150, 2.01.H: Taking exception to screens as this is not available on enclosed motors.
 - ◆ Section 16150, 2.01.I: Item 3 – Taking exception to 600% inrush, quoted motor will be rated at 635%
- H. Deliverables
 - ◆ Submittals 2 – 3 weeks from receipt of acceptable order
 - ◆ Manufacturing time is 16 weeks after formal release to manufacture



CARTER VERPLANCK

4910 W CYPRESS ST.
TAMPA, FLORIDA 33607
www.carterverplanck.com

Phone: 813.287.0709

Fax: 813.282.8216

Quotation

To: Wharton-Smith
Attn: Matthew Peterson
Fax:

Date: 12/19/2017
Re: SJCUD – Players Club WRF
Section 11214 (VTPs) & 11650 (End
Suction Pumps)

WE ARE PLEASED TO QUOTE YOU ON THE FOLLOWING MATERIAL FOR ACCEPTANCE WITHIN 30 DAYS

Section 11650 (End Suction Pumps)

- A. On-Site Reuse Pumps Centrifugal Enclosed Impeller: Three (3) D814-3X1.5X13F frame mounted pumps, each with a baseplate, and 25HP, 1800rpm, TEFC motor:
- ◆ Each pump will be equipped with the following:
 - a. 316SS casing
 - b. 316SS Impeller
 - c. TB Woods coupling
 - d. Steel coupling guard
 - e. Steel bearing housing and 316SS adapter
 - f. Component type mechanical seal
 - g. Channel steel baseplate with drip lip rim
- B. Band Screen and Compactor Booster Pump Centrifugal Enclosed Impeller: One (1) D814-1.5X1X8F frame mounted pumps, each with a baseplate, and 2HP, 1800rpm, TEFC motor.
- ◆ Each pump will be equipped with the following:
 - a. 316SS casing
 - b. 316SS Impeller
 - c. TB Wood Coupling
 - d. Steel coupling guard
 - e. Steel bearing housing and 316SS adapter
 - f. Component type mechanical seal
 - g. Channel steel baseplate with drip lip rim
- C. Testing
- ◆ Factory
 - a. Each pump will be given a non-witness factory performance test with a calibrated shop test motor. All tests and calculations will be in accordance with the latest requirements of HI standards.
 - ◆ Onsite
 - a. 1 day for training
 - b. 1 day for startup and performance testing
 - c. Basic vibration and noise testing, per spec.
- D. Spare parts for entire order as follows:
- ◆ One spare mechanical seal for the reuse pumps.
 - ◆ One pump, wet-end, Band Screen and Compactor Booster Pump Centrifugal Enclosed Impeller
- E. Freight (included)
- ◆ Price includes all forgoing, CPT Ponte Vedra, FL
- F. Items not included:
- ◆ Off-loading at jobsite, any labor or tools for Assembly or Installation, Field operation.
 - ◆ Suction or Discharge piping, mechanical couplings, supports, tie rods, leveling screws, fittings, etc
 - ◆ Air relief valves / Vacuum valves / Isolation valves, etc.



CARTER | VERPLANCK

4910 W CYPRESS ST.
TAMPA, FLORIDA 33607
www.carterverplanck.com

Phone: 813.287.0709

Fax: 813.282.8216

Quotation

To: Wharton-Smith
Attn: Matthew Peterson
Fax:

Date: 12/19/2017
Re: SJCUD – Players Club WRF
Section 11214 (VTPs) & 11650 (End Suction Pumps)

WE ARE PLEASED TO QUOTE YOU ON THE FOLLOWING MATERIAL FOR ACCEPTANCE WITHIN 30 DAYS

- ◆ Seal water or drain accessories such as piping, flow indicators, pressure reducing valves, Y strainers, fittings or tubing
- ◆ Gauges, T cocks, anchor bolts, templates or accessories
- ◆ VFDs or any type of Controls, Instrumentation, MCCs, Starters, Power Factor Correction Capacitors, Panels, cable, wiring, conduits, temperature or vibration probes, remote controls, or any auxiliary electrical equipment extraneous to the pump motors
- ◆ Standard tools or tool chests, lubricants, grease fitting extensions or grease guns
- ◆ Field painting, touch-up paint supply

Coordination Notes/Comments:

- ◆ Section 01300 Submittals
 - a. 1.03.F.5.a [Comment]: PE not called out in End Suction Section. PE certification form not to be provided.
- ◆ Section 11650 End Suction Pumps
 - a. 1.06.A.1, 2.01.E [Clarification]: Flowserve to provide anchor bolts and locations. Analysis of anchor bolts by others.
 - b. 1.08.B.1 [Comment]: Only spare mechanical seal to be provided for entire package.
 - c. 1.10.A [Clarification]: Manufacture standard warranty to be 12 months from installation or 18 months from shipment, whichever occurs first. Ins and outs will not be covered.
 - d. 2.01.E [Clarification] Base plate to be coated with epoxy ready bottom coat standard.
 - e. 2.01.G [Exception]: Casing to be upgraded to 316SS.
 - f. 2.01.H [Exception]: Impeller to be upgraded to 316SS.
 - g. 2.01.I [Clarification]: Type 51 seal to be provided. This is the same design as the Type 31 seal with a slimmer profile for you use on the D800 pump.
 - h. 2.01.K [Clarification]: Pump to have single row radial bearing and then single row radial and thrust bearing.
 - i. 2.01.L [Comment]: Ball valve by others.
 - j. 2.01.P [Clarification]: Re-use pump to be tested per HI 1U standards. Band screen and booster pump to be tested per HI 14.6 standards 1U does not apply.
 - k. 3.04.D [Clarification]: Pump to meet HI standard for vibration.
- ◆ Section 16150 Electric Motors
 - a. 2.01.H [Exceptions]: Screens are not available on enclosed type motor.
 - b. 2.02.B.1 [Exception]: 2HP motor to exceed 600% inrush limit.

G. Deliverables:

- ◆ Submittals, 8 weeks from receipt of acceptable order
- ◆ Manufacturing, 20 weeks after formal release to manufacture



CARTER I VERPLANCK
 4910 W CYPRESS ST.
 TAMPA, FLORIDA 33607
 www.carterverplanck.com

Phone: 813.287.0709
 Fax: 813.282.8216

Quotation

To: Wharton-Smith
 Attn: Matthew Peterson
 Fax:

Date: 12/19/2017
 Re: SJCUD – Players Club WRF
 Section 11214 (VTPs) & 11650 (End
 Suction Pumps)

WE ARE PLEASED TO QUOTE YOU ON THE FOLLOWING MATERIAL FOR ACCEPTANCE WITHIN 30 DAYS

Item	Description	Amount
0001	Vertical Turbine & Horizontal End Suction Pumps as detailed above	\$223,133.00
0002	6% Florida Sales Tax	\$13,387.98
0003	0.5% St. Johns County Surtax (on first \$5,000)	\$ 25.00
	Total =	\$236,545.98

Price includes freight.

Please Note:

1. We pressure gauges, anchor bolts, wire cable, conduit, piping, installation, hook-up, field testing, control panels or any other accessories or other ancillary items which are not specifically called out in this scope of supply.
2. Under no circumstances will Carter & VerPlanck, Inc. or its suppliers be liable for any incidental, consequential, liquidated, special or late delivery damages whatsoever.
3. Payment terms are 100% net 30 days from delivery with approved credit. Our prices based upon no retainage.
4. Pricing is based upon Carter & VerPlanck, Inc. and the manufacturer's Standard Terms and Conditions of Sales. Copies of these documents are attached herewith for your review and reference. No other terms or conditions of sale will apply unless accepted in writing by an officer of the company.

TERMS: 100% Net 30 days after Invoice date
 ODP PURCHASE ORDER NEEDS TO BE
 ISSUED FOR FOLLOWING
 EQUIPMENT PRICE - \$223,133
 FREIGHT - INCLUDED
 Site Services - INCLUDED
 TOTAL - \$223,133

QUOTATION DOES NOT INCLUDE ANY SALES OR USE TAX
 PAYABLE UNDER ANY STATE OF FEDERAL STATUE

CARTER & VERPLANCK, INC.

BY Brandon Lang, P.E.

DEDUCTION FROM WHARTON-SMITH
 EQUIPMENT PRICE - \$223,133.00
 TAX - \$ 13,387.98
 SURTAX - 25.00
 FREIGHT - INCLUDED
 Site Services - INCLUDED
 TOTAL - \$236,545.98

C: 813-481-5200
 brandonlang@carterverplanck.com

TOTAL TAX SAVING - \$13,412.98



CARTER | VERPLANCK

4910 W CYPRESS ST.
TAMPA, FLORIDA 33607
www.carterverplanck.com

Phone: 813.287.0709

Fax: 813.282.8216

Quotation

To: Wharton-Smith
Attn: Matthew Peterson
Fax:

Date: 12/19/2017
Re: SJCUD – Players Club WRF
Section 11214 (VTPs) & 11650 (End
Suction Pumps)

WE ARE PLEASED TO QUOTE YOU ON THE FOLLOWING MATERIAL FOR ACCEPTANCE WITHIN 30 DAYS

TERMS & CONDITIONS OF SALE

- 1) Neither Carter & VerPlanck, Inc. nor the manufacturer(s) will be liable for damages of any kind, whether direct, consequential, incidental, special or liquidated.
- 2) The quoted price may include systems or components from more than one vendor. Carter & VerPlanck, Inc., will provide separate prices for individual systems or components upon request, although the total price of all items quoted may vary as a result.
- 3) Price does not include any gauges, gauge cocks, tools, lubricants, installation, anchor bolts, spare parts, start-up service or other items not specifically called out herein.
- 4) Price does not include any motor starters, controls, or power factor correction devices other than as specifically called out herein.
- 5) THE WARRANTY EXTENDED BY THE MANUFACTURER(S) IS IN LIEU OF ALL OTHER OBLIGATIONS, LIABILITIES OR WARRANTIES OF MERCHANTABILITY, FITNESS OR OTHERWISE, EITHER EXPRESS OR IMPLIED, BY FACT OR BY LAW, AND STATES OUR ENTIRE AND EXCLUSIVE LIABILITY AND BUYER'S EXCLUSIVE REMEDY FOR ANY CLAIM OF DAMAGES IN CONNECTION WITH THE SALE OR FURNISHING OF GOODS OR PARTS, THEIR DESIGN, SUITABILITY FOR USE, INSTALLATION OR OPERATION. WE FURTHER SPECIFICALLY EXCLUDE ANY EXPRESS OR IMPLIED WARRANTIES REFERENCE UNDER FLORIDA STATUTE #718.203. THERE ARE NO WARRANTIES WHICH EXTEND BEYOND THE DESCRIPTION ON THE FACE HEREOF.
- 6) **NOT INCLUDED:** Unless specifically set forth in the scope of the quotation, this offer **does not** include:
 - start-up assistance or field services
 - interconnecting wiring and/or conduit
 - installation labor
 - installation supervision
 - motor control equipment
 - motor starters or contactors
 - power distribution equipment
 - miscellaneous mechanical and mounting hardware
- 7) **FREIGHT:**
 - A) All prices are F.O.B. factory or suppliers' shipping point with freight prepaid and included to the jobsite.
 - B) Title and Risk of Loss passes to CONSIGNEE AT SHIPPING POINT.
 - SELLER prepays freight charges.
 - SELLER bears freight charges.
 - CONSIGNEE must file claims for loss or damage, (if any).
 - C) Seller will not consider any claim for damage or shortage unless it is noted on the bill of lading at time of receipt. It is the responsibility of the CONSIGNEE to verify that all items contained on the bill of lading are received prior to accepting shipment.
- 8) **TAXES:**

The prices quoted are exclusive of, and Purchaser shall pay and make all returns for, any Federal, State, or local sales, use, transfer, or similar taxes applicable to the equipment and material once the same have been delivered as provided herein.
- 9) **VALIDITY OF PRICING:**

The prices stated herein are contingent upon receipt of a firm order, or letter of intent, in an acceptable form from Purchaser within 30 days from the date of this offer, and Purchaser's willingness to accept delivery when the factory is prepared to ship. If a responsive firm order is not received by the above date, Seller shall have the right to withdraw this quotation and to revise the prices and shipping dates provided herein.
- 10) **PAYMENT TERMS:**

Seller's payment terms are that all invoices are due and payable within thirty (30) days of the date thereof with approved credit. Interest on the unpaid balance at the rate of 11/2% per month, or the maximum permitted by law, whichever is less will be added to all outstanding invoices which are not paid within 30 days. **Our price is based on no retainage.**
- 11) **DELIVERY:**



CARTER | VERPLANCK

4910 W CYPRESS ST.
TAMPA, FLORIDA 33607
www.carterverplanck.com

Phone: 813.287.0709

Fax: 813.282.8216

Quotation

To: Wharton-Smith
Attn: Matthew Peterson
Fax:

Date: 12/19/2017
Re: SJCUD – Players Club WRF
Section 11214 (VTPs) & 11650 (End
Suction Pumps)

WE ARE PLEASED TO QUOTE YOU ON THE FOLLOWING MATERIAL FOR ACCEPTANCE WITHIN 30 DAYS

The shipping dates provided herein are based on Seller's current information as to availability of material and components and our best estimate as to dates on which we will be able to ship. These dates are subject to revision or postponement because of unavailability of material and components or because of events beyond our control.

If Purchaser requests postponement of previously agreed to shipping date(s), Seller may invoice the Purchaser, or then require payment for all of such equipment and material as is then ready for shipment; and, from and after the date that such equipment and material or any portion thereof is ready for shipment, any expenses or other charges incurred by Seller in regards to the same shall be at Purchaser's expense and Purchaser shall promptly pay any invoice rendered by Seller in regard thereto.

12) SERVICE:

No start-up assistance or field services are included unless specifically called out in our offering. If so included, the Seller will furnish Field Service Engineer(s) as described in our proposal, at the time of start-up, to inspect the completed system, to advise in regard to placing the system in initial operation and to instruct operating personnel on the proper use of the equipment and material. The proper installation, start-up and operation of the system and any further changes to be made in the system, responsibility for servicing, and all labor costs thereof, shall be the responsibility, under the control and at the risk of the Purchaser. At the time start-up service is requested we ask you to be **completely** prepared, including where and as appropriate, the availability of power, water, flow, access, etc. so that start-up may proceed as anticipated. Any return trips to the site or additional time required as a result of failure to be so prepared, will be charged to the customer at the prevailing demand service rate.

If service additional to that provided for therein is required, Seller, if available, shall furnish at the expense of the Purchaser, competent service engineers at Seller's then prevailing rates, plus travel and living expenses, to assist in additional service in regard to the equipment and material or in regard to equipment furnished by Purchaser. All charges in connection with such service shall be billed by the Seller and shall be due and bear interest at the Company's normal payment terms unless Seller shall require other payment terms and conditions.

13) GENERAL:

The descriptions, terms and conditions contained in this Proposal and the terms and conditions contained in the Manufacturer's Standard Terms attached hereto, which are incorporated herein by reference, constitute the quotation of the Seller. To the extent that the descriptions, terms and conditions contained in the Proposal are inconsistent with the Manufacturer's Standard Terms, the Manufacturer's Standard Terms are modified by this Description.

14) No order shall be deemed accepted by the Manufacturer until the Purchaser is notified of its acceptance by the Manufacturer. Carter & Verplanck, Inc., is not an agent or employee of the Manufacturer(s) and is not authorized to accept orders in its (their) behalf.

15) Any suit or proceeding brought by Purchaser to enforce this agreement, to resolve any dispute over its terms, or to sue for damages for its breach shall be brought only in a state or federal court of appropriate jurisdiction in Hillsborough County, Florida. Purchaser expressly waives any objection that venue in Hillsborough County is inconvenient or improper.

16) In any suit or proceeding brought to enforce this agreement, to resolve any dispute over its terms, or to sue for damages for its breach, the prevailing party shall recover a reasonable attorneys' fee in addition to costs of suit.

COGBURN BROS. ELECTRIC, INC.

Phone: (904) 358-7344

3300 Faye Road

Fax: (904) 358-9846

Jacksonville, Florida 32226

Jeff Sutton

Outside Sales

World Electric Supply

www.cogburnbros.com



World Electric Supply
green

Request for Quotation

Direct 904.423.4812 // Cell 904.994.1563

Email jeff.sutton@worldelectricsupply.com

TO: World Electric Supply

CO: Jeff Sutton

Page 1 of 2

REF: Players Club WRF-St. Johns County, Fl-Bids 9/27/2017

Bids Due: 09-27-2017

Quantity	Type	Description	Amount	Per	Total
		GEAR			
1		MCC1			
1		MCC2			
1		MCC3			
1		MCC4			
1		MCC5			
1		MCC6			
0		VFD's/75HP/140A for Turbo Blowers			
1		MCCL			
1		112.5 KVA XFMR			
1		Panel L1			
1		Panel L2			
1		Panel L3			
1		Panel L4			
1		Panel L5/Nema 12-316 SS			
2		60A Lighting Contactor LC			
14		3P/30A/NF/4X/316SS Disconnect			
25		E-Stop with Lockable Hasp/4X/316SS Complete			
1		MCC4A			
1		MCC5A			
0		75 KVA XFMR			
1		30 KVA XFMR			
1		Panel L6/with SPD			
1		3P/60A/NF/4X/316SS Disconnect			
1		Nema 12 Manual Motor Starter for On/Off Control			
5		Nema 4x Manual Motor Starter for Exh.Fan Disc.			
1		Note 3/Sheet E-22 starter			
		Freight to St. Johns County , Fl 32028			

Taxes for St Johns County

FL Sales Tax	\$30,865.00
Freight	Included
TOTAL	\$544,865.00

By quoting, you assure compliance with all specifications and agree to provide all required shop drawings, submittals, O&M Manuals, spare parts and training.

COGBURN BROS. ELECTRIC, INC.

Phone: (904) 358-7344

3300 Faye Road

Fax: (904) 358-9846

Jacksonville, Florida 32226

Jeff Sutton

Outside Sales

World Electric Supply

www.cogburnbros.com



World Electric Supply
green

Request for Quotation

Direct 904.423.4812 // Cell 904.994.1563

Email jeff.sutton@worldelectricsupply.com

TO: World Electric Supply

CO: Jeff Sutton

Page 2 of 2

REF: Players Club WRF-St. Johns County, Fl-Bids 9-27-2017

Bids Due: 9-27-2017

Quantity	Type	Description	Amount	Per	Total
		Gear (Continued)			
2		Open-Close-Auto Sw/Nema 4X/316 stainless steel complete unit			
2		Nema 4X Manual Motor Starter for On/Off Control 316 SS Complete Unit			
1		Main Switchboard shown on E-2			
		Eaton Notes & Exceptions:			
		1. Eaton Selling Policy 25-000 applies			
		2. Studies Included per Spec 16015			
		3. Start-Up and Training Included per Spec 16400, Paragraph 3.01			
		4. Qty (4) 75 HP VFD are NOT Included			
		5. Note: 30 KVA Transformer in MCC-6			
		6. Spares Included per Spec 16010.			
		7. Eaton is quoting materials and services through Addendum #4.			
		8. Allow 10-12 Weeks for Submittals for Approval.			
		WES Eaton Gear Quotation	\$514,000.00	LOT	
		World Electric Supply Jeff Sutton 9/27/17			
		Freight to St. Johns County , Fl 32028			
		SUBTOTAL			\$514,000.00
		Freight			Included
		TOTAL			\$544,865.00

By quoting, you assure compliance with all specifications and agree to provide all required shop drawings, submittals, O&M Manuals, spare parts and training.

If St Johns County would like to issue an ODPO as a cost savings on the taxes for the Eaton Bill of Material above, there would be a savings of \$30,865.00.

see comments on next page

ODP PURCHASE ORDER NEEDS TO BE ISSUED FOR FOLLOWING

EQUIPMENT PRICE	-	\$514,000
FREIGHT	-	INCLUDED
Site Services	-	INCLUDED
<u>TOTAL</u>	-	\$514,000

DEDUCTION FROM WHARTON-SMITH

EQUIPMENT PRICE	-	\$514,000
TAX	-	\$ 30,840
SURTAX	-	25
FREIGHT	-	INCLUDED
Site Services	-	INCLUDED
<u>TOTAL</u>	-	\$544,865

TOTAL TAX SAVING - \$30,865

Leslie S. Samel, PE, BCEE.
Mott MacDonald
10245 Centurion Parkway, Suite 320
St. Augustine, FL 32084

ENAQUA
A Grundfos Innovation Company
2410 Birch Street
Vista, CA 92081
Phone: (+1)7605992644
Fax: (+1)7605992642
www.enaqua.com

Name: Arijit Sarkar
Email: asarkar@grundfos.com
Date January 26, 2017

REF: St Johns County, Players Club Water Reclamation Facility
SUB: Statement of Qualifications-for Proposal for UV disinfection system-Enaqua Ref No:
ASR_P17USFL01

Dear Leslie,

The manufacturer's statements of qualification and verification as listed and required by the UV RFP for the referenced project (dated 01/20/2017) are provided in this letter.

1. Enaqua hereby attests that the proposed (referenced) UV system meets all requirements of NWRI 2012 at MDF of 4.32 MGD at 55.0 % UVT with four (4) UV banks per channel operational, and one bank per channel stand by at MDF. The proposed UV reactors have been validated by an independent third party (Carollo Engineers) per NWRI 2012 protocol.
2. A confidential hard copy of the Bioassay Validation Report, the End of Lamp Life Report, and Fouling Factor Testing report is being provided to Leslie S. Samel, PE, BCEE, and Jacob N. Wadkins, EI under a signed NDA from both recipients.
3. The conceptual layouts provided by Mott MacDonald meets the manufacturer's suggested layout.
4. The all-inclusive equipment package price for the scope of supply listed in RFP Table dated 01/20/2017, and as detailed in Section 8 of the proposal is US\$ \$812,965.00. The all-inclusive equipment package shall be honored by Enaqua for twenty four (24) months from the date of this proposal. Enaqua shall not seek any cost of escalation for twenty-four months from date of this proposal.

Sincerely,



Arne Diering
CEO

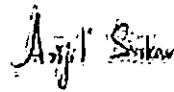

Arijit Sarkar
Applications Engineer

NON-CONTACT UV DISINFECTION SYSTEM –
PROPOSAL FOR RFP- 55.00% UVT

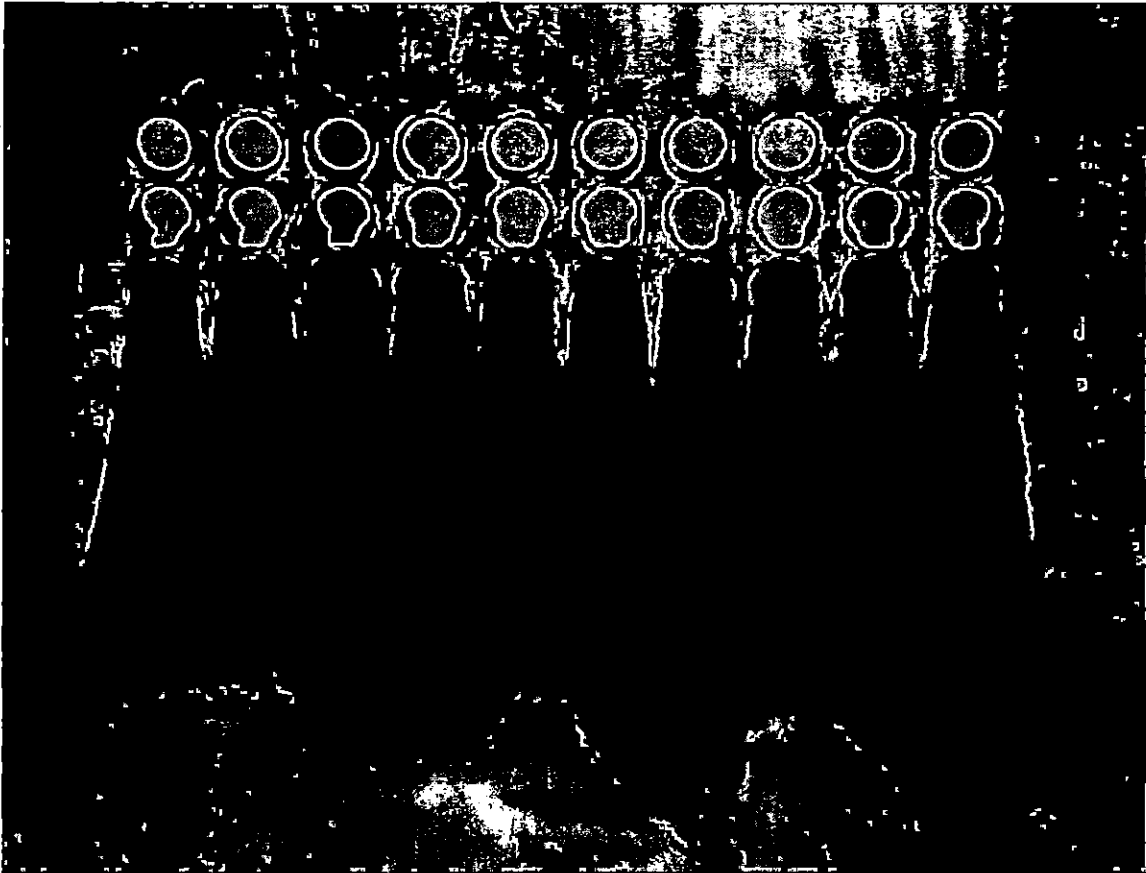

St Johns County, Players Club Water Reclamation
Facility - UV DISINFECTION SYSTEM FOR REUSE-
55.00% UVT

Prepared For:

Leslie S. Samel, PE, BCEE.
Associate
Mott MacDonald
10245 Centurion Parkway
Suite 320
St. Augustine, FL 32084

DOCUMENT REVISION HISTORY

Name	Date	Reason For Change	Revision #
Proposal For RFP Submittal	01/25/2017	N/A	0

Leslie S. Samel, PE, BCEE.
Mott MacDonald
10245 Centurion Parkway, Suite 320
St. Augustine, FL 32084

ENAQUA
A Grundfos Innovation Company
2410 Birch Street
Vista, CA 92081
Phone: (+1)7605992644
Fax: (+1)7605992642
www.enaqua.com

Name: Arijit Sarkar
Direct : 760 599 2644
Email: asarkar@Enaqua.com
Date January 26, 2017

REF: St Johns County, Players Club Water Reclamation Facility
SUB: Proposal for UV disinfection system-

Enaqua Ref No: ASR_P17USFL01

Dear Leslie,

Enaqua is pleased to provide the following proposal for Non-Contact UV Disinfection Systems for 55.00% UVT for the above referenced project. The UV configuration outlined in this proposal is the same as the 55.0 % UVT proposal provided to Mott MacDonald for review on 1/12/2.17, and supplementary information requested in the RFP Table dated 01/20/2017 are included in this proposal.

The all-inclusive equipment package price for the scope of supply listed in RFP Table dated 01/20/2017, and as detailed in Section 8 of this proposal is US\$ \$812,965.00. The all-inclusive equipment package shall be honored by Enaqua for twenty four (24) months from the date of this proposal. Enaqua shall not seek any cost of escalation for twenty-four months from date of this proposal.

Enaqua Non-Contact UV Disinfection Systems have been proven to provide superior performance, resistance to fouling and scaling, combined with electrical efficiency and minimum maintenance. The lack of quartz sleeves and seals completely eliminate the need for automated cleaning systems, acid baths, hoists, and the replacement cost of the quartz sleeves housing the lamps.

Please do not hesitate to contact us with any questions you may have regarding this proposal, or the Enaqua Non-Contact UV Disinfection system operation. Thank you for your interest in in Enaqua and the opportunity to provide you with this proposal.

Regards,



Arne Diering
CEO

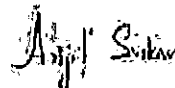

Arijit Sarkar
Applications Engineer

Your Equipment Representative Contact person:

Your Enaqua Sales Contact:

Ernest (E.G.) Williams
Sales Engineer

Rick McIntyre (Regional Sales Manager)
Tel: (+1) 760 936 1979



Environmental Equipment Services

E mail: rmcintyre@grundfos.com

3616 Harden Blvd, #337
Lakeland, FL 33813
Tel: (863)640-0201
E mail: egw@ees-fl.com

SUMMARY:

The details of the reactor(s), scope of supply, reactor drawings, summarized O & M information, and other pertinent information are provided in the following sections.

1. DESIGN CRITERIA:

The flow rates and water quality parameters used for reactor sizing are listed in the table 1.1 below:

Table 1.1: UV Design criteria

Peak Hourly Flow Rate (Hydraulic capacity of UV system)	6.5/4,514.0	(MGD)/(GPM)
Maximum Monthly Flow Rate/ Peak Reuse Disinfection Flow rate	4.32/ 3,000.00	(MGD)/(GPM)
Average Daily Flow rate	2.4/1,667.0	(MGD)/(GPM)
UV Transmittance	55.0	% UVT (Minimum)
Number of UV Trains/Channels	2	Active at peak flow
Total Suspended Solids*	5.0	mg/l (30 day average)
Total BOD*	5.0	mg/l (30 day average)
Permit Limit 1: Fecal Coliform Permit Limit- Public Access Reuse	75% of samples ND/25.0 CFU.	75.0% of effluent samples non-detect for Fecal Coliform. Single sample max of 25.0 CFU/100 ml.
Permit Limit 2: Fecal Coliform Permit Limit- Surface Discharge	< 200.00/ 800.00	7 day geometric mean of < 200.00 CFU/100 ml, and single sample maximum of 800.00 CFU/100 ml.
Disinfection UV Reduction Equivalent Dose +	100.0	Minimum MS2 RED of 100.0 mJ/cm ² . UV Dose calculated per Independent Third Party Bioassay conducted in accordance with NWRI 2012- after applying certified- Lamp End Of Lamp Life (EOLL) of 87%, and Fouling Factor of 89%.
Plant Process	Biological Nutrient Removal (BNR) and media Filtration prior to UV Disinfection	
Particle Size*	<10.0	Microns
Total Iron*	0.3	mg/l
NTU*	< 2	NTU
Equipment Redundancy	25.00%	Of UV active Banks per UV train at Maximum Monthly Flow

*Note: Industry standard values used for this concept level proposal

+ Note: Per NWRI 2012

2. PROPOSED PROCESS FLOW & DESIGN REDUNDANCY:

The proposed process flow diagram is shown in the Figure 1 below and the flow ranges of the UV reactor(s) are presented in the Table 2.1 below. The proposed configuration consists of two parallel UV trains, with – two double bank UV reactors, and one single bank UV reactor per train. Four (4) operating banks/ UV train are designed to provide the design UV RED at maximum month flow for the water quality parameters listed in table 1. The design redundancy is 25.0 % of UV Banks per train at maximum monthly flow.

Figure 1: Preliminary Process Flow diagram

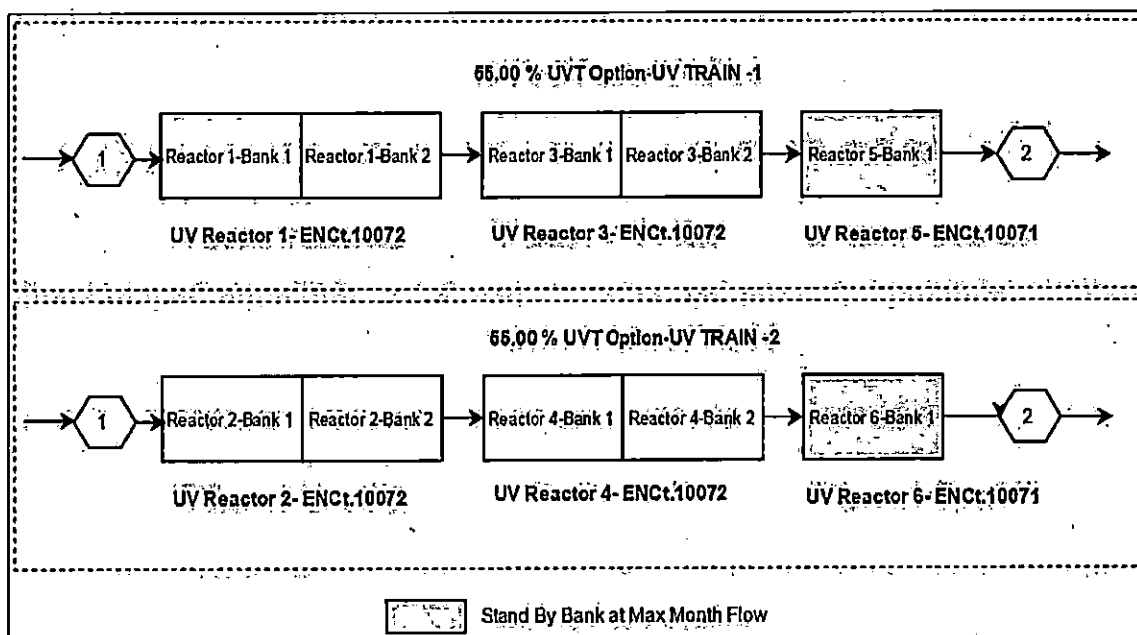

Table 2.1: Preliminary Process Flow

Tag	Description	Peak Reuse Disinfection Flow rate (MGD)/ GPM for Validated UV Dose of 100.0mJ/cm ² @ 55.0% UVT
1	Filtered Influent to UV train 1- Reactors 1, 3, & 5 (Four UV Banks Operational)	2.16/1,500.00
2	Disinfected Effluent from UV train 1- Reactors 1, 3, & 5 (Four UV Banks Operational)	2.16/1,500.00
3	Filtered Influent to UV train 2- Reactors 2, 4, & 6 (Four UV Banks Operational)	2.16/1,500.00
4	Disinfected Effluent from UV train 2- Reactors 2, 4, & 6 (Four UV Banks Operational)	2.16/1,500.00

3. SCOPE OF SUPPLY:

Summary details of the proposed reactor selected to meet the effluent permit criteria (based on the water quality parameters listed in Table 1.1) are provided in Table 3.1 and 3.2 below:

Table 3.1: Scope of Supply – UV Reactor(s)

Reactor Model Number-UV reactors 1, 2, 3, & 4	ENCt.10072 (Double Bank Reactors)
---	-----------------------------------

Reactor type	In Pipe Flanged/ In Channel
Process Connections	18.00" Ø, CL 150 Flange/ Standard Enaqua Channel Flange Adapter
Installation notes	Outdoor covered or indoor Installation
Reactor Configuration	Validated Per NWRI 2012.
UV Lamps	145 W Low Pressure High Intensity Non Amalgam
Non-contact Reactor Material	C Series- AFP840™ Tube
Material of construction	316 Stainless Steel
UV REACTOR	
Number of proposed UV Reactor(s)	4
Number of Banks per Reactor	Two (2)
Number of AFP Tubes/ Bank	70 (In two bank length)
Number of Lamp Racks per Bank	8
Number of Lamps per Lamp Rack	12
Number of lamps per Bank	96
Total number of lamps (reactor)	192
Total number of ballasts (reactor)	192
Reactor Model Number: UV reactors 5 & 6	ENCT-10071 (Single Bank Reactors)
Reactor type	In Pipe Flanged/ In Channel
Process Connections	18.00" Ø, CL 150 Flange/ Standard Enaqua Channel Flange Adapter
Installation notes	Outdoor covered or indoor Installation
Reactor Configuration	Validated Per NWRI 2012.
UV Lamps	145 W Low Pressure High Intensity Non Amalgam
Non-contact Reactor Material	C Series- AFP840™ Tube
Material of construction	316 Stainless Steel
UV REACTOR	
Number of proposed UV Reactor(s)	2
Number of Banks per Reactor	One (1)
Number of AFP Tubes/ Bank	70 (In single bank length)
Number of Lamp Racks per Reactor	8
Number of Lamps per Lamp Rack	12
Total number of lamps (reactor)	96
Total number of ballasts (reactor)	96
Total number of lamps in all five reactors (system)	960

Table 3.2: Scope of Supply – Controls, Instruments, and Level Control Mechanism

UV INTENSITY SENSORS	
Number of UV intensity Monitors	10 (1 per Bank)
CONTROLS & ELECTRICAL	
ADR	6 (1 per reactor)
EDC (Ensure Dosing Controller) and SCADA integration	2 (1 Per UV Train)

Power Distribution / Disconnect Panels	10 (1 per Bank)
UV system HMI Panel- 19.00" Touchscreen	1 (common)
UV System Master Control PLC. AB Compact Logix PLC with PanelView 1000 HMI, and I/O Modules and SCADA integration.*	1
INSTRUMENTS INCLUDED IN PROPOSAL	
Ultrasonic Level Sensor	2 (one per UV train)
HACH in-line UVT analyzer (UVAS SC Sensor, mounting assembly, and sc200 controller)	1
EFFLUENT LEVEL CONTROL INCLUDED IN PROPOSAL	
Downward Opening Penstocks and AUMA intelligent actuators	2 (one per UV Channel)

*Note: MOTOROLA ACE 1000 RTU may be supplied as UV system Master Control PLC if preferred by County.

Table 3.3: Spare parts included in the proposal pricing includes:

NO.	ITEM	QTY
1	Ballast (10.0 % of all ballasts)	96
2	UV lamps (10.0 % of all lamps)	96
3	AFP Tubes (10.0 % double bank length reactor)	28
4	AFP Tubes (10.0 % single bank length reactor)	14
5	Wipers	N/A
6	Chemical Supply	N/A
5	Operator's safety kit	4
6	Cleaning Kit	4

4. OPERATING CONDITIONS:

The reactor head loss at peak flow rate and the total connected load of the reactor are provided in the Table 4.1 below:

Table 4.1: Operating conditions

Calculated Head loss (inches)-Flange to Flange	Total Connected Load Per Reactor @ 480 V 3 Ø
UV Reactors 1& 3 (ENCT.10072)- at Peak Hourly flow rate	< 6.25" ^{**} Total connected Load per UV Reactor ENCT.10072/ ENCT.10071 (kW) 29.624/14.872
UV Reactors 5 (ENCT.10071)- at Peak Hourly flow rate	< 5.5" ^{**} Total connected Load [(kVA) calculated with a PF of .95] 28.34/15.65
Combined Head loss through all three UV reactors at Peak flow rate	< 18" ^{**} Total connected Load per UV Reactor (Amps)* 34.0/18.82

*Note: Total connected load for the UV reactors (double bank/single bank reactor) and associated cooling and control components

+Note: Peak hourly flow of 6.5 MGD split equally between two UV channels/ trains. Flange to flange head loss through three UV reactors at flow. Major losses (due to piping) between UV reactors and minor losses (due to valves and fittings) between UV reactors are not included in calculation of head loss.

5. OPERATIONS & MAINTENANCE INFORMATION:

The power usage at ADF flow (kW), based on 24/7 operations at average daily flow rate are provided in Table 5.1 below:

Table 5.1: Power usage at average

Actual Calculated Power Usage	
Flow Rate	kW
Average Daily Flow rate (2.4 MGD) @ 55.0 % UVT	64.96 [^]

[^]Note: Both UV trains and four (4) banks per train active using level pacing. Six vertical rows of AFP tubes in each train (42 AFP tubes per train, and 84 AFP tubes in both trains) flooded and associated UV lamps active, used for estimating power usage. With 42 AFP tubes per train flooded at 1.2 MGD per train at 55.0% UVT, the RED is 109.0 mJ/cm².

GENERAL MAINTENANCE:

The AFP840™ Tube reactors are the only UV transmitting reactor component that is in contact with waste water, and the AFP840™ tubes have been demonstrated to have high resistance to fouling. No cleaning chemicals are required/ necessary for cleaning of the AFP840™ tubes. The cleaning procedure is very simple and cleaning instructions are provided in the O&M manual and the brush attachment for manual cleaning is supplied with the reactors.

6. ELECTRICAL REQUIREMENTS:

The electrical requirements for the proposed reactor(s) are provided in Tables 6.1, and 6.2 below:

Table 6.1: Electrical requirements per Double Bank UV Reactor (ENCt.10072)

1. Each Reactor requires an electrical supply of Two (2) 480V/3P 4 wire (plus ground) – 30.0 A (One per bank)
2. Each Reactor Cooling System & Control requires an electrical supply of Two (2) 120V/ 1P/ 2 wire (plus ground) – 20 A (One per bank)
3. Each HMI Panel requires an electrical supply of one (1) 120V/ 1P/ 2 wire – 20 A
4. UV Master Control PLC requires electrical supply of one (1) 120V/ 1P/ 2 wire – 20 A
5. In Line UV Transmittance Analyzer requires electrical supply of one (1) 120V/ 1P/ 2 wire – 20 A

Note: Based on 60Hz power

Table 6.2: Electrical requirements per Single Bank UV Reactor (ENCt.10071)

1. Each Reactor requires an electrical supply of One (1) 480V/3P 4 wire (plus ground) – 30.0 A
2. Each Reactor Cooling System & Control requires an electrical supply of One (1) 120V/ 1P/ 2 wire (plus ground)

Note: Based on 60Hz power

7. STANDARD EQUIPMENT WARRANTIES:

- A. The equipment furnished (excluding lamps, ballasts) shall be warranted to be free of defects in material and workmanship, including damages that may be incurred during shipping for a period of 12 months after startup and commissioning.
- B. **UV LAMPS:** UV lamps shall be warranted for a minimum of 12,000 hours operating time under the conditions specified herein without proration. In the event of premature UV lamp failure, the UV system supplier shall offer the following:
 - a. Lamp failure before 12,000 hours – send a replacement lamp free of charge
- C. **BALLASTS:** Electronic ballasts are fully warranted for ten (10) years operating time under the conditions specified herein without proration. In the event of premature ballast failure, the UV system supplier shall offer the following:
 - a. Ballast failure before ten (10) years – send a replacement ballast free of charge

8. ALL INCLUSIVE PRICING FOR UV EQUIPMENT PRICING:

A detailed breakdown of the UV system pricing per the scope, services, shipping, and taxes is provided in Table below.

Table 8.1: Proposal Pricing Table

NO.	DESCRIPTION	UNIT PRICE	QTY.	SUB-TOTAL
1	UV Reactors 1-4 (Model ENct.10072)	\$139,950.00	4	\$559,800.00
2	UV Reactors 5 & 6 (Model ENct.10071)	\$69,975.00	2	\$139,950.00
3	Power Disconnects, & HMI Panels	-	Per table 3.2	Included
4	Project Submittal Documents & O&M Documents	-	Per Submittal Requirements	Included
5	Spare Parts Included	-	Per Table 3.3	Included
6	Downward Opening Penstocks and AUMA intelligent actuators	\$7,500.0	2	\$15,000.00
7	UV Master Control PLC, AB Compact Logix PLC with Panel View 1000 HMI, and I/O Modules and SCADA integration.	\$12,500.00	1	\$12,500.00
8	HACH in-line UVT analyzer (UVAS SC Sensor, mounting assembly, and sc200 controller)	\$18,000.00	1	\$18,000.00
Net sales price				\$745,250.00
Sales Tax (6.0%)				\$ 44,715.00
Start up and Commissioning Services. Per Table 8.2				\$15,500.00
Shipping and Handling*				\$7,500.00
*TOTAL ALL INCLUSIVE EQUIPMENT PACKAGE PRICE				\$812,965.00

See Notes on next Page

+Note: Shipping is FOB Jobsite. Players Club WRF, St Johns County, FL.

***Note:** All inclusive Proposal price shall be honored by Enagua for twenty four (24) months from the date of this proposal. Enagua shall not seek any cost of escalation for twenty four months from date of this proposal.

Table 8.2: Startup Services and Site Visits Included in Scope of Proposal:

NO.	ITEM	QTY*
1	Installation	Two 8 hour days
2	Inspection and Certification	One 8 hour day
3	Startup and Testing	Five 8 hour days
4	Training	Two 8 hour days
Minimum Total Number of Trips		4

*Note: Travel time to site, and travel expenses included in Pricing in Table 8.1

9. MECHANICAL DRAWINGS:

Sales Engineering drawings of the proposed UV reactors are provided in Figure 2 & 3 as follows:

ODP PURCHASE ORDER NEEDS TO BE ISSUED FOR FOLLOWING
 EQUIPMENT PRICE - \$745,250
 FREIGHT - \$ 7,500
Site Services - \$ 15,500
 TOTAL - \$768,250

DEDUCTION FROM WHARTON-SMITH
 UV Equipment Allowance = \$815,000

TOTAL TAX and Allowance Savings - \$46,750

FIGURE 2: UV Reactors 1, 2, 3, & 4 (Model ENCt.10072)

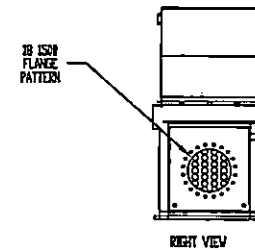
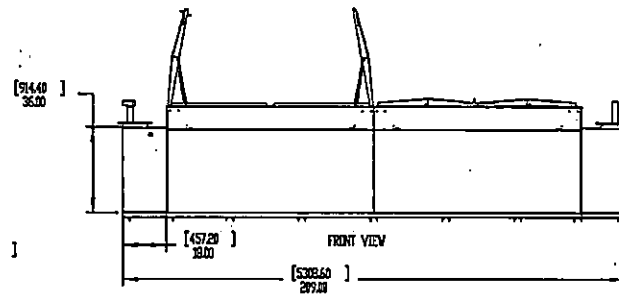
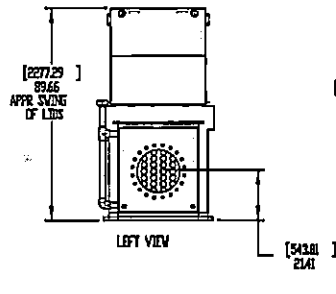
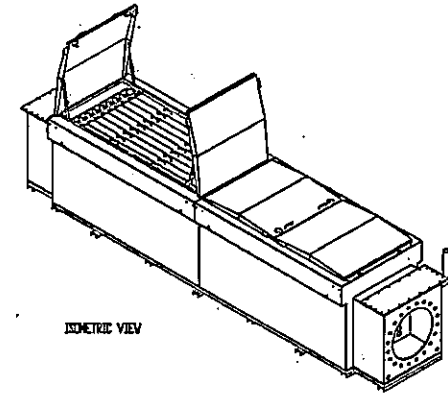
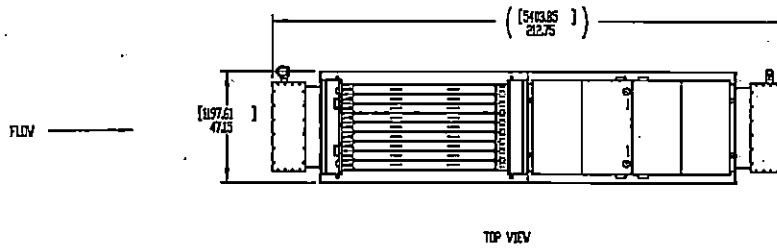

SALES ENGINEERING DRAWING
NOT FOR INSTALLATION

Notes (unless otherwise specified)

1. Drawing in accordance with ASME Y14.5-2009.
2. All dimensions in inches or millimeters.
3. All wetted components of stainless steel, AFP, or non-corrosive materials.

PROPRIETARY AND CONFIDENTIAL THE INFORMATION CONTAINED IN THIS DRAWING IS THE SOLE PROPERTY OF ENAQUA. ANY REPRODUCTION IN PART OR AS A WHOLE WITHOUT THE WRITTEN PERMISSION OF ENAQUA IS PROHIBITED.		UNLESS OTHERWISE SPECIFIED DIMENSIONS ARE IN" (INCHES/CM)		240 Birch St. Vista, CA 92081	
		TOLERANCES: ANGLES:		APPROVALS DATE	
XX ± 1/254 X ± 1' XXX ± 13/76 X ± 3' XXXX ± .010 X ± 25' XXXXXX ± .003		DRAWN ASR_Rev 01/11/2017		TITLE SE DRAWING, MODEL ENCB-L10072	
MATERIAL N/A		DATE 01/11/2017		SIZE B REV. A	
FINISH N/A		FILE ENCB-L10072_RevA		SCALE 1:48 SHEET 1 OF 1	

FIGURE 3: UV Reactors 5 & 6 (Model ENcT.10071)

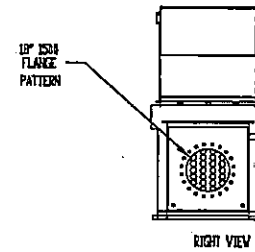
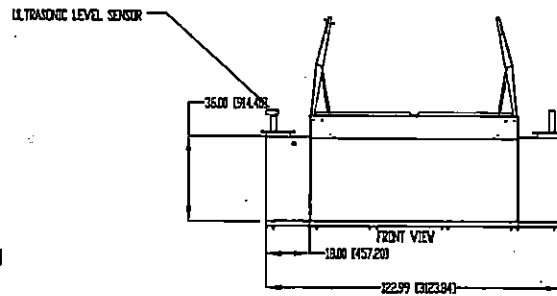
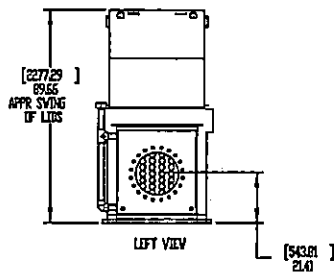
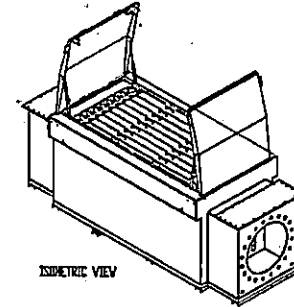
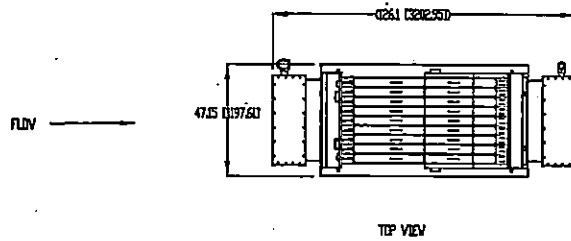

SALES ENGINEERING DRAWING
NOT FOR INSTALLATION

Notes (unless otherwise specified)

Drawing in accordance with ASME Y14.5-2009.
All dimensions in inches or millimeters.
All wetted components of stainless steel, AFP,
or non-corrosive materials.

PROPRIETARY AND CONFIDENTIAL THE INFORMATION CONTAINED IN THIS DRAWING IS THE SOLE PROPERTY OF ENAGUA. ANY REPRODUCTION IN PART OR AS A WHOLE WITHOUT THE WRITTEN PERMISSION OF ENAGUA IS PROHIBITED.	UNLESS OTHERWISE SPECIFIED DIMENSIONS ARE IN INCHES/mm		2411 Birch St. Vista, CA 92081		
	TOLERANCES:		DATE: 3/24/15	TITLE: SE DRAWING, MODEL ENCBT.10072	
	XX ± .1/254 XXX ± .03/76 XXXX ± .010 XXXXXX ± .0009	ANGLES: X ± 1° Y ± 5° ZX ± 25°	DESIGNED BY: ASR	CHECKED BY: B	REV: A
	MATERIAL: N/A	FINISH: N/A	PART NO: ENCBT.10072_RevA	SCALE: 1:48	SHEET 1 OF 1



Ponte Vedra WWTP "Players Club" St. Johns, FL

High Speed Turbo Blower

Bid Scope of Supply
Proposal # 10430

Submitted by:

APGN Inc. *dba* APG – Neuros

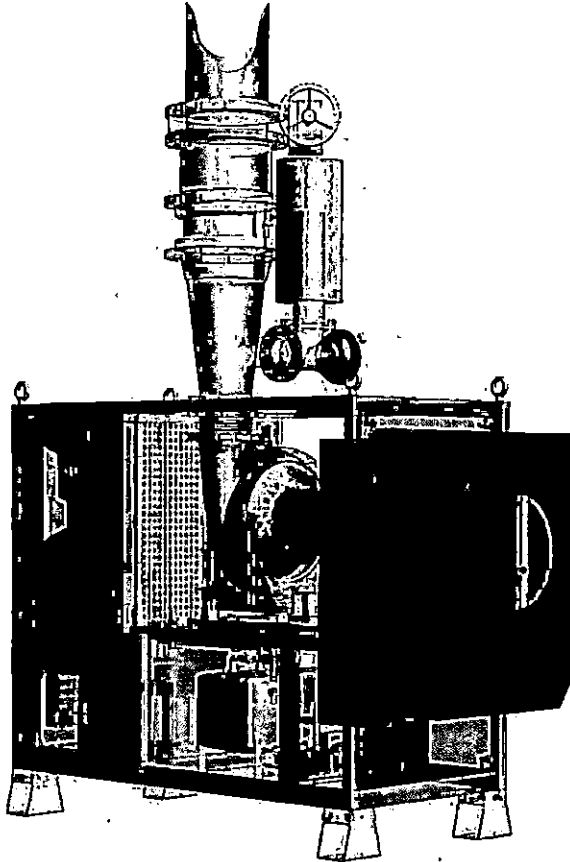

APGN Inc. *dba* APG-Neuros

1270 Michèle-Bohec, Blainville, Québec J7C 5S4, Canada, Tel : (450) 939-0799

www.apg-neuros.com



December 22, 2017

Ponte Vedra WWTP "Players Club" St. Johns, FL

Reference: Specification 11371 – Turbo Blowers and Appurtenances, Addendum #1 dated August 28, 2017, Addendum #2 dated September 7, 2017 Addendum #3 dated September 20, 2017 and Addendum #4 dated September 21, 2017

Subject: Request for Proposal – Supply of Process Aeration Equipment

Dear Sir / Madame,

APG-Neuros is pleased to submit the following proposal in response to the above referenced inquiry.

APG-Neuros Turbo Blower Scope of Supply:

- A. Four (4 = 3 Duty, 1 Standby) NX75-C070 APG-Neuros NX Turbo Blowers system packages, to be installed *indoors*, rated for conditions as shown on the specification, complete with integrated components as follows:
- Blower core including high efficiency impeller, permanent magnet synchronous motor, bump-foil air bearings
 - High Performance, UL & CSA certified, KEB Variable Speed Drive and Inverter specially tuned for high speed motor, 3/60/480 Volts
 - Input Line Reactor to minimize harmonics
 - Sine-wave (sinus) filter for cooler running motor
 - Blower Local Control Panel and 6" AB Panel View Plus Touch Screen – c/w Allen Bradley CompactLogix L24PLC
 - Provisions for Remote Control capability via Ethernet, LAN or Hard-wiring
 - Temperature sensors for motor, bearing, inlet and discharge air flow
 - Pressure sensors for inlet and discharge conditions
 - Pressure sensor and alert for air filter condition
 - Built in Flow Indication
 - Built in Speed measurement
 - Voltage Surge Protection
 - Internal Expansion Joint
 - Internal vibration and dynamic effect Absorption Mounts
 - Built in vibration sensor, transmitter and display
 - Harmonic Filter -- Passive type meets IEE 519
 - Integrated blower dual filtration comprised of a coarse pre-filter and a fine pleated filter – 90% by weight per ASHRAE 52-76 with a 98% efficiency @ 10 microns (nom).
 - Uninterruptible Power Supply for PLC - Industrial grade – (10 minutes)
 - All above components within a sound attenuating enclosure with a *Louvered* Inlet
 - Actuated valves to be provided by contractor, per agreement and to meet specifications.
- B. Each blower is complete with following ship loose items:
- One (1) Discharge Expansion Cone, 8"
 - One (1) Blow-off bypass valve to blow off air flow during start/shutdown sequence
 - One (1) Blow-off silencer to silence air flow during start/shutdown sequence
 - One (1) US Valve wafer style discharge Check Valve, 8"

APG-Neuros Proprietary Information Provided in Strict Confidence



- One (1) ABZ lugged type discharge Butterfly valve with manual Operator, 8"
- One (1) Maxi-Joint EPDM flexible connector for discharge, 8"

Additional Aeration Equipment and Instrumentation Included with this Proposal:

- One (1) Complete standalone, Allen Bradley CompactLogix based master Control Panel (MCP) c/w 10" AB Touchscreen OIT, built with its own state-of-the-art technology microprocessor in a self-contained enclosure.

MCP operates based on input and output signals to control and stage up to Four (4) online Turbo blowers based on a user input command set-point - e.g. - Pressure, DO, Flow etc. sent from a SCADA system via Ethernet, or manual input.

MCP can accommodate field instrumentation for upto Four (4) separate zones assuming each zone consists of the standard control and feed-back instrumentation - i.e. - 1 DO Probe, 1 Flow meter, and 1 Air Control-Valve.

(Final Design/Price of the MCP can only be determined after review of the MCP specification and related sections. (All power and wiring to and from all field instrumentation by others.)

- Four (4) differential pressure gauges - stainless steel case, 4-1/2-in nominal diameter with a Type 316 stainless steel Bourdon tube and a 300 series stainless steel movement. 1 1/4-in NPT Type 316 stainless steel socket with a bottom connection. Gauges for shall have a 0 to 30 psi range and have an accuracy of at least plus or minus 1 percent scale. *(All field installation and connections for these gauges by others).*
- One (1) Main Header Pressure Transmitter, by Siemens, Model Sitrans P, DS III series digital pressure transmitter – Range 0-30 Psi.*

**Note – All power and control wiring to all supplied field instrumentation is by others.*

Technical Data and Cut Sheet can be provided upon request

C. Submittal Information: Copies as required

- Qualifications of APG-Neuros
- Quality of construction
- Power Guarantee
- Product Data
- Detailed Drawings
- Quality Control
- Certified Blower test
- Operation and Maintenance Manuals

D. Payment Terms:

- 100% upon delivery to the job site.
- All payment invoices are paid Net 30 and must be paid in full prior to start-up scheduling
- 1.5% Interest charge per month will be added to past due accounts.
- Payment shall not be dependent on the buyer being paid by any third parties or equipment acceptance by owner.

E. Proposal Validity and Seller Terms and Conditions

APG-Neuros Proprietary Information Provided in Strict Confidence



- Unless otherwise specified elsewhere in the Sales Agreements, the prices in this proposal are valid for ninety (90) days from the issue date on the cover page.
- This proposal, unless otherwise specified herein this document, is subject to the Seller's General Terms and Conditions of Sales available upon request.
- Final price is subject to change contingent on final conformed specification review, if applicable.

F. Factory Inspection and Tests

- Factory Acceptance Performance Test to ASME PTC-10 'Type 2' standard

G. Warranty

- Blowers and appurtenances (parts and labor) will be warranted for a period of One (1) year from the date of start-up not to exceed eighteen (18) months from delivery, whichever occurs first.

H. Technical Support

- APG-Neuros will provide services of a qualified technician on site for start-up, field testing and operator training for a total of Six (6) days, performed in Four (4) trips to site. These visits will include supervision of blower installation and field-start-up assistance, and operator training as specified.
- Integration of four (4) new turbo blowers with proposed MCP and existing plant SCADA.
- On-Site Harmonic mitigation testing of the blowers at the PCC being power-entry point to the blowers to be done in One (1) Trip / One (1) Day.

I. Spare parts

- Four (4) sets of inlet air filters
- One (1) tool box and tool kits

J. Quality Assurance / Certifications

- APG-Neuros Turbo Blower is UL1450 certified
- APG-Neuros production system is certified to ISO 9001

K. Price covering Items A through J above.....	USD \$460,867.00
Florida Sales Tax (6%).....	USD \$27,652.00
St. Johns County Tax (0.5% on first \$5,000.00).....	USD \$25.00

L. Lot Price.....USD \$488,544.02

See comments on following page

- Price is Net F.O.B. shipping destination, and Excludes Taxes.

Price adders, can be provided when requested or required in specifications at following additional cost (not included in the price above):

- Additional On-site Technical Assistance per day	\$2,000.00
- Additional Warranty Coverage (per year)	\$25,000.00
- Simulated Harmonic Analysis	\$Included

APG-Neuros Proprietary Information Provided in Strict Confidence



- Witnessing Engineer Cost
(Price is per witness, and includes airfare Tampa, FL – Plattsburgh, NY (round-trip), 1 Day/1 Night hotel, Car Rental and related Per Diem) \$2,600.00
- Witnessed PTC-10 Test
(Price includes the witnessing of One (1) units Performance Test as per PTC-10 test code and corresponding Blower Package Functional Test.) \$2,300.00

M. Delivery Lead time

- Submittals shall be issued two (2) weeks from manufacturers acceptance of PO
- Blowers shall be shipped twelve (12) weeks from approval of shop drawings.

N. Exclusions

The following items are not included in this scope of supply and shall be the responsibility of others.

- Anchor Bolts
- Seismic Calculations
- Blower Installation
- Uninterruptible Power Supply external to the enclosure
- Piping for suction, discharge, gauge, vent, seal, etc. and miscellaneous fittings
- Electrical and Controls of any kind beyond those provided inside the Turbo Blower enclosure or otherwise listed in this scope of supply.

We appreciate the opportunity to quote APG-Neuros Turbo Blowers and look forward to a successful project.

For any questions regarding Procurement, Service and Warranty information, please contact:

APG-Neuros Sales Department
 1270 Michèle-Bohec
 Blainville, Québec J7C 5S4
 Phone 450-939-0799
 Fax 450-939-2115

ODP PURCHASE ORDER NEEDS TO BE ISSUED FOR FOLLOWING

EQUIPMENT PRICE - \$460,867
FREIGHT - INCLUDED
Site Services - INCLUDED
TOTAL - \$460,867

DEDUCTION FROM WHARTON-SMITH

EQUIPMENT PRICE - \$460,867.02
TAX - \$ 27,652.02
SURTAX - 25.00
FREIGHT - INCLUDED
Site Services - INCLUDED
TOTAL - \$488,544.02

TOTAL TAX SAVING - \$27,677.02



Penn Valley Pump Co., Inc.

998 Easton Road • Warrington, PA 18976

Ph: 215-343-8750 • Fax: 215-343-8753

www.pennvalleypump.com

Date: December 18, 2017

Quote: 17024

To: Bidding Contractors

Project: Players Club WRF

Engineer: Mott MacDonald

Section: 11300 Reciprocating Positive Displacement Pumps

SCOPE OF WORK

We are pleased to offer our proposal for supply only of material and services in general accordance with the subject specification section(s) as clarified or noted below.

Scum Pumps: P-3110 and P-3210

Two (2) 4" Model 4DDSX30CNU Simplex Penn Valley Double Disc Pump™ units based on the following: Pump body in Class 30 Cast iron with neoprene elastomers, mounted on a static 304 stainless steel mounting base with 5HP, 1200RPM 230-460/3/60 TEFC severe duty, inverter ready motor with thermal overloads. Pump and motor connected via belt and pulley drive for a final capacity of 75GPM at 15ft TDH. Assembly complete with suction and discharge pulsation dampeners, full OSHA 304 stainless steel approved guards and covers. All surfaces prepared and primed and/or painted as indicated by the specifications.

Belt Press Feed Pump: P-8100

One (1) 8" Model 8DDDX214 Duplex Penn Valley Double Disc Pump™ units based on the following: Pump body in Class 30 Cast iron with neoprene elastomers, mounted on a static 304 stainless steel mounting base with 25HP, 1200RPM 230-460/3/60 TEFC severe duty, inverter ready motor with thermal overloads and space heater. Pump and motor connected via belt and pulley drive for a final capacity of 250GPM at 108ft TDH. Assembly complete with suction and discharge pulsation dampeners, full OSHA 304 stainless steel approved guards and covers. All surfaces prepared and primed and/or painted as indicated by the specifications.

Three (3) Model PVP420VS Suction vacuum switch assemblies consisting of 1" NPT SS316 sensor, adjustable pressure switch and 4" (30"HG - 30psi) stainless steel gauge.

Three (3) Model PVP420PS Discharge pressure switch assemblies consisting of 1" NPT SS316 sensor, adjustable pressure switch and 4" (0 - 100psi) stainless steel gauge.

One (1) Set of spare parts for Model 4DDSX30 to consist of: two (2) discs, two (2) trunnions, one (1) clack valve and one (1) set of gaskets.

One (1) Set of spare parts for Model 8DDDX214 to consist of: four (4) discs, four (4) trunnions, two (2) clack valve and two (2) set of gaskets.

Two (2) Days of start-up and training services.

One (1) Set of project submittals and O&M manuals as required.

ODP PURCHASE ORDER NEEDS TO BE ISSUED FOR FOLLOWING
 EQUIPMENT PRICE - \$85,198
 FREIGHT - \$ 1,600
 Site Services - \$ 2,400
 TOTAL - \$89,198

Net Equipment Sales Price: \$85,198.00
 Sales Tax: (6.0%) \$ 5,112.00
 Start-up & Commissioning: \$ 2,400.00
 Shipping & Handling \$ 1,600.00
 Total Price (Including Tax): \$94,310.00

DEDUCTION FROM WHARTON-SMITH
 EQUIPMENT PRICE - \$85,198.00
 TAX - \$ 5,111.88
 SURTAX - \$ 25.00
 FREIGHT - \$ 1,600.00
 Site Services - \$ 2,400.00
 TOTAL - \$94,334.88

TOTAL TAX SAVING = \$5,136.88

Clarifications and Deviations:

None

Commercial Terms:

Terms: 95% Net 30 days, 5% balance not to exceed 90 days after start-up

Validity: This proposal is valid for ninety (90) days from issue date. After this time we reserve the right to make price adjustments.

Delivery: 10 - 12 weeks after receipt of approved submittals

Submittals: 3 - 4 weeks after receipt of purchase order

Shipping: F.O.B. Factory, Warrington, PA with full freight allowed to Jobsite
Estimated weight of shipment is 5,300lbs.

The following items are not included:

- Installation
- Foundations, anchor bolts, grouting and foundation design
- Utilities including air, water and power
- Motor starters, Variable Frequency Drives (VFD's) or Controls
- Spare parts, unless detailed in scope of work above
- Field applied coatings
- Field installed piping and pipe supports
- Field installed interconnecting wiring, conduit and cable tray
- Permits, taxes and import duties

If there are any questions regarding this scope of work or any additional information is required, please feel free to contact me at 215-343-8750 or our local representative listed below.

Envirosales of Florida, Inc.
Contact: Joe Sacco
e-mail: joe@envirosalesofflorida.com
Ph: 904-524-9576

Proposed by:
PENN VALLEY PUMP CO., INC.

Preston Campbell





Date: January 2, 2018
Project: Players Club WRF
Subject: Taxable portion of the PO for the Secondary Clarifiers

The total purchase order for the Secondary Clarifiers is \$251,441. The non-taxable portion of the order is \$30,735 (for Freight, Engineering and Service) the taxable portion of the order is \$220,706

If you have any questions or need additional information please contact me at

Sincerely,

Tor Heimdal P.E.
Sedimentation Group Manager
Ovivo USA
Tor.heimdal@ovivowater.com
(801) 931-3296

ODP PURCHASE ORDER NEEDS TO BE ISSUED FOR FOLLOWING

EQUIPMENT PRICE	-	\$220,706
FREIGHT	-	\$ 30,735
Site Services	-	w/ above
TOTAL	-	\$251,441

DEDUCTION FROM WHARTON-SMITH		
EQUIPMENT PRICE	-	\$220,706.00
TAX	-	\$ 13,242.36
SURTAX	-	25.00
FREIGHT	-	\$ 30,735.00
Site Services	-	w/ above
TOTAL	-	\$264,708.36

TOTAL TAX SAVING - \$13,267.36

Ovivo USA, LLC
4246 Riverboat Road, Suite 300 Tel: 801.931.3000
Salt Lake City, Utah Fax: 801.931.3080
84123
USA www.ovivowater.com



December 21, 2017

Project : St John's County- Players Club WRF

Subject : Taxable portion of the PO for the Grit Removal Equipment

The total purchase order for the OVIVO grit Removal Equipment is \$225,968.00.
The non- taxable portion, which will include freight and site services will be \$18,600.00 and the taxable portion will be \$207,368.00

Aby Varghese
Inlet Works –Group Product Manager
OVIVO USA
Aby.Varghese@ovivowater.com
Cell: 832-802-3256

ODP PURCHASE ORDER NEEDS TO BE ISSUED FOR FOLLOWING
EQUIPMENT PRICE - \$207,368
FREIGHT - \$18,600
Site Services - w/above
TOTAL - \$225,968

DEDUCTION FROM WHARTON-SMITH
EQUIPMENT PRICE - \$207,368.00
TAX - \$12,442.08
SURTAX - 25.00
FREIGHT - \$18,600.00
Site Services - w/above
TOTAL - \$238,435.08
TOTAL TAX SAVING - \$13,837.42



**RW GATE
COMPANY**

RW GATE COMPANY
PO BOX 33
TROY, NEW YORK 12181
OFFICE: 518-874-4750
FAX: 518-274-0210
WEBSITE: www.rwgate.com

December 18, 2017

St. Johns County, FL

Subject: **Players Club Water Reclamation Facility**
Section 11280 - SLIDE GATES & STOP LOGS
Dwg No. CD-2 - ALUMINUM FLAP GATE

ODP PURCHASE ORDER NEEDS TO BE ISSUED FOR
FOLLOWING

EQUIPMENT PRICE	- \$70,138
FREIGHT	- \$ 5,700
<u>Site Services</u>	- w/ above
TOTAL	- \$75,838

DEDUCTION FROM WHARTON-SMITH	
EQUIPMENT PRICE	- \$70,138.00
TAX	- \$ 4,208.28
SURTAX	- 25.00
FREIGHT	= \$ 5,700.00
<u>Site Services</u>	- w/ above
TOTAL	- \$80,071.28

TOTAL TAX SAVING - \$4,233.28

To Whom It May Concern:

The price for the RW Gate Company equipment listed in the referenced specification and drawing herein is \$70,138. The price for the freight and field service is \$5,700. The total selling price is \$75,838.

Please contact me if you require additional information.

Thank you.

Sincerely,

G. Evan F. Whipps
Co-Owner



TSC-JACOBS NORTH

24156 S.R. 54, Suite 3, Lutz FL 33559 | (813)242-2660 PHONE | (813)242-2597 FAX

December 22, 2017

To Whom It May Concern:

Subject: St. John's County – Players Club WRF

The total sell price to TSC Jacobs North for the purchase of the WEMCO Grit Pumps, Ford Hall Algae Brush Systems, and the MFG Weirs and Baffles, on the above-referenced project is \$193,076.00. If you have any questions, or if you need anything additional, please do not hesitate to contact me.

Sincerely,

Paul C. Wachter III, P.E.
V.P. of Sales

ODP PURCHASE ORDER NEEDS TO BE ISSUED FOR FOLLOWING
EQUIPMENT PRICE - \$193,076
FREIGHT - INCLUDED
Site Services - INCLUDED
TOTAL - \$193,076

DEDUCTION FROM WHARTON-SMITH
EQUIPMENT PRICE - \$193,076.00
TAX - \$ 11,584.56
SURTAX - 25.00
FREIGHT - INCLUDED
Site Services - INCLUDED
TOTAL - \$204,685.56

TOTAL TAX SAVING - \$11,609.56



440 Park 32 West Drive
Noblesville, IN 46060

December 20, 2017

Wharton-Smith, Inc.
PO Box 471028
Lake Monroe, FL 32771

c.o. TSC Jacobs North

RE: Players Club WRF Ponte Vedra Beach, St. John's County, FL - Section 11372
Positive Displacement Blowers, WS Purchase Order # 217159-001

Dear Project Manager,

Universal Blower Pac has been issued a contract by your company to supply equipment for subject project for the total quoted price of \$149,677. Of this amount, \$144,338 would be considered taxable.

Thank you for your business. Please contact me if you have any questions.

ODP PURCHASE ORDER NEEDS TO BE ISSUED
FOR FOLLOWING

EQUIPMENT PRICE	-	\$144,338
FREIGHT	-	\$ 5,339
Site Services	-	w/ above
TOTAL	-	\$149,677

DEDUCTION FROM WHARTON-SMITH		
EQUIPMENT PRICE	-	\$144,338.00
TAX	-	\$ 8,660.28
SURTAX	-	25.00
FREIGHT	-	\$ 5,339.00
Site Services	-	w/ above
TOTAL	-	\$158,362.28

TOTAL TAX SAVING - \$8,685.28

Cordially,

Andrew Placek, PE
Director of Sales and Marketing
Universal Blower Pac, Inc.

440 Park 32 West Drive
Noblesville, Indiana 46062
P >> 317.773.7256
F >> 317.776.5086



UNIVERSALBLOWERPAC.COM
HYBRIDBLOWER.COM



**Xylem Water Solutions USA Inc. /
Flygt Products**
2412 Birds Eye Court Orange Park, FL 32003
Phone: 239-825-8384 • Fax: 407-904-215-4079

To: Bidding Contractors

Date: November 14, 2017

Subject: Players Club WRF
Quote Number: 2017-APO-1454

We are pleased to offer the following equipment:

RAS pumps (section 11312)

- (3) 6" Flygt NT3127.070/422 dry - pit submersible waste water pumps, 7.5HP, FM rated, 3/460V, each with 50' of motor cable, inlet elbows & pump stands.
- (3) Plotted 3300 #14-699890 certified pump tests.
- (1) #7206300 spare mechanical seals.
- (1) #7692802 spare hard iron N-impeller kit.
- (8) Anchor bolts, 316 stainless steel.
- (2) Days of startup service by a representative of this company.

WAS pumps (section 11312)

- (2) 3" Flygt NT3085.185/463 dry - pit submersible waste water pumps, 2.3HP, FM rated, 3/460V, each with 50' of motor cable, inlet elbows & pump stands.
- (2) Plotted 3300 #14-699890 certified pump tests.
- (1) #7204500 spare mechanical seals.
- (1) #7682840 spare hard iron N-impeller kit.
- (12) Anchor bolts, 316 stainless steel.
- (2) Days of startup service by a representative of this company.

Internal recycle – propeller pumps (section 11313)

- (4) Flygt PP4640.492/837 propeller waste water pumps, 4HP, FM rated, 3/460V, each with 50' of motor cable.
- (4) Plotted PP4600 #14-699518 certified pump tests.
- (4) #14-407129 minicas pump sensors.
- (4) #7190301 4640 connection disc, PP 316 stainless steel 4640 pipe mount.
- (1) 2" upper guide rail brackets, 316 stainless steel.
- (1) Cable holder, 316 stainless steel.
- (4) 15' lengths of 3" diameter guide rail, 316 stainless steel.
- (4) 10' lengths of 3" diameter guide rail, 316 stainless steel.
- (2) 25' "grip - eye" pump lifting cables, 316 stainless steel.
- (24) Anchor bolts, 316 stainless steel.
- (2) Thern #5PT10S 316 -M1 portable Davit crane, marine grade w/hand winch & pedestal base.
- (1) Day of startup service by a representative of this company.

In-plant PS (section 11312)

- (2) 6" Flygt NP3127.070/438 submersible wastewater pumps, 10HP, 3/460V, FM rated, each with 50' of motor cable.
- (2) 6" x 6" Flygt discharge connections.
- (1) Flygt #5565101 mix flush valve.
- (2) #14-699512 certified plotted factory pump tests.
- (1) Duplex 10HP/230V control panel built to St. Johns County standards.
- (1) St. Johns County SCADA panel with Motorola radio & jumper cable per specifications.
- (4) ENM mechanical floats, each with 65' of cable.
- (1) #7206300 spare mechanical seals.
- (1) #7692802 spare hard iron N-impeller kit.
- (8) Anchor bolts, 316 stainless steel.



**Xylem Water Solutions USA Inc. /
Flygt Products**
2412 Birds Eye Court Orange Park, FL 32003
Phone: 239-825-8384 • Fax: 407-904-215-4079

- (1) 2" upper guide rail brackets, 316 stainless steel.
- (1) Cable holder, 316 stainless steel.
- (4) 20' lengths of 3" diameter guide rail, 316 stainless steel.
- (2) 20' "grip - eye" pump lifting cables, 316 stainless steel.
- (1) 36" x 48" 300# PED load rated access cover w/safety grating.
- (2) Startup service by a representative of this company.

Grinder PS (section 11270)

- (2) 2" Flygt MP3102.890/212 submersible grinder pumps, 6 HP, 3/460V, FM rated, each with 50' of motor cable.
- (2) 2" x 2" Flygt discharge connections.
- (1) Flygt #5565101 mix flush valve.
- (2) #14-699512 certified plotted factory pump tests.
- (1) Duplex 6HP/230V control panel built to St. Johns County standards.
- (1) St. Johns County SCADA panel with Motorola radio & jumper cable per specifications.
- (1) #6931905 repair kit.
- (1) #4865402 212 spare impeller.
- (4) ENM mechanical floats, each with 65' of cable.
- (1) Flygt Top pre-plumbed fiberglass 48" x 132" deep, wetwell w/aluminum hatch cover & safety grating.
- (1) Top self-cleaning bottom.
- (1) 2" discharge connection.
- (1) 3" Charcoal activated vent.
- (2) 3/4" upper guide rail brackets, 316 stainless steel.
- (1) Cable holder, 316 stainless steel.
- (4) 11' lengths of 3/4" diameter guide rail, 316 stainless steel.
- (2) 15' "grip - eye" pump lifting cables, 316 stainless steel.
- (1) Startup service by a representative of this company.

Pre - anoxic mixers (section 11224)

- (3) Flygt model SR-4660 submersible mixers, 316 stainless steel, 15HP, 3/460V, FM rated, each with 50' of motor cable.
- (3) Plotted 2.2 certified mixer thrusts tests.
- (12) Anchor bolts, 316 stainless steel.
- (2) Mixer mast assembly, 30' x 4" 316 stainless steel.
Positioner plate, wall brackets, w/extension, pivoting base, static loop cable & anchor bolts.
- (2) Thern #5PT10S 316-M1 portable Davit crane, marine grade w/hand winch & pedestal base.
- (1) Startup service by a representative of this company.

Post - anoxic mixers (section 11224)

- (3) Flygt model SR-4650 submersible mixers, 316 stainless steel, 8.3HP, 3/460V, FM rated, each with 50' of motor cable.
- (3) Plotted 2.2 certified mixer thrusts tests.
- (2) Mixer mast assembly, 30' x 4" 316 stainless steel.
Positioner plate, wall brackets, w/extension, pivoting base, static loop cable & anchor bolts.
- (2) Thern #5PT10S 316-M1 portable Davit crane, marine grade w/hand winch & pedestal base.
- (1) Startup service by a representative of this company.

Sanitaire fine bubbler aeration equipment (section 11375)

Sanitaire coarse bubbler aeration equipment (section 11383)



Sanitaire bid scope see separate attachment.

**Xylem Water Solutions USA Inc. /
Flygt Products**
2412 Birds Eye Court Orange Park, FL 32003
Phone: 239-825-8384 • Fax: 407-904-215-4079

Total package price: \$669,997.00

SEE COMMENTS ON NEXT PAGE

Exclusions: WE DO NOT SUPPLY, PIPING, VALVES, GUIDE BARS, PRESSURE GAUGES, DISCONNECTS, JUNCTION BOXES, KELLUMS GRIPS, SURGE PROTECTION EQUIPMENT, SPARE PARTS, LABOR OR ANY OTHER ITEM NOT SPECIFICALLY LISTED ABOVE.

PLEASE MAKE PURCHASE ORDERS OUT TO: XYLEM WATER SOLUTIONS USA, INC.

Validity: THIS QUOTE IS VALID FOR NINETY (90) DAYS UNLESS LONGER TIME AGREED TO IN WRITING.

Taxes: State, local, and other applicable taxes are not included in this quotation.

Freight Terms: DAP; Jobsite - Full Freight Allowed (per Incoterms 2010)

Shortages: Xylem will not be responsible for apparent shipment shortages or damages incurred in shipment that are not reported within two weeks from delivery to jobsite. Damages should be noted on the receiving slip and the truck driver advised of the damages. Please contact our office as soon as possible to report damages or shortages so that replacement items can be shipped and the appropriate claims made.

Payment Terms: 100% NET 45 DAYS AFTER SHIPMENT DATE.
(Note: Partial billing will be made on partial shipments)

Xylem's payment shall not be dependent upon Purchaser being paid by any third party unless Owner denies payment due to reasons solely attributable to items related to the equipment being provided by FLYGT.

Schedule: Please consult your local Flygt branch for submittals and fabrication lead-times.

Back Charges: Buyer shall not make purchases nor shall Buyer incur any labor that would result in a back charge to Seller without prior written consent of an authorized employee of seller.

Terms & Conditions: *This order is subject to the Standard Terms and Conditions of Sale – Xylem Americas effective on the date the order is accepted which terms are available at <http://www.xyleminc.com/en-us/Pages/terms-conditions-of-sale.aspx> and incorporated herein by reference and made part of the agreement between the parties.*

We thank you for your interest in our equipment and look forward to being of service to you in the near future.

IN THE ABSENCE OF A FORMAL ISSUED PURCHASE ORDER, A SIGNED COPY OF THIS PROPOSAL IS ACCEPTABLE AS A BINDING CONTRACT.

Xylem Water Solutions USA, Inc.

Company Name: _____

Address: _____

xylem
Let's Solve Water



Xylem Water Solutions USA Inc. /
Flygt Products
2412 Birds Eye Court Orange Park, FL 32003
Phone: 239-825-8384 • Fax: 407-904-215-4079

Accepted By: _____

Print Name: _____

Date: _____

David Williams

Dave Williams

ODP PURCHASE ORDER NEEDS TO BE ISSUED FOR FOLLOWING
EQUIPMENT PRICE - \$669,997
FREIGHT - INCLUDED
Site Services - INCLUDED
TOTAL - \$669,997

DEDUCTION FROM WHARTON-SMITH
EQUIPMENT PRICE - \$669,997.00
TAX - \$ 40,199.82
SURTAX - 25.00
FREIGHT - INCLUDED
Site Services - INCLUDED
TOTAL - \$710,221.82

TOTAL TAX SAVING - \$40,224.82



Designed to Protect.
Built to Perform.™



Michael Williams, Sales General Manager
Hydro-Dyne Engineering
4750 118th Ave N
Clearwater, FL

January 2, 2018

Matt Peterson, Project Manager – Water/Wastewater
Wharton-Smith, Inc.
750 Monroe Road
Sanford, FL 32771

To whom it may concern,

This letter is in reference to the purchase of Mechanical Bandscreen and Screenings Wash Press for Players Club Water Reclamation Facility, The total purchase price for Bid No: 17-70 Section 11330, Mechanical Band Screen and Screenings Wash Press, is \$200,000/tax not included.

If any additional information is required, please contact me directly.

Sincerely,

Michael Williams

ODP PURCHASE ORDER NEEDS TO BE ISSUED FOR FOLLOWING	
EQUIPMENT PRICE	- \$200,000
FREIGHT	- INCLUDED
Site Services	= INCLUDED
TOTAL	- \$200,000

**DEDUCTION FROM WHARTON-SMITH
BANDSCREEN ALLOWANCE - \$200,0000**

TOTAL ALLOWANCE SAVING - \$0.00





354 State Route 29, Greenwich, New York 12834

Phone No 518-695-6851

E-mail: aj@bdpindustries.com

To: Sean White
Wharton Smith Inc.
750 Monroe Road
Sanford, FL 32771

October 27, 2017

Re: Players Club Water Reclamation Facility, Ponte Vedra, FL
Section 11361, Addendum #1, 2, 3 & 4 - Belt Filter Press System
BDP Quotation # 092117-1625 – One (1) 2.0 mtr, 3DP Belt Press

BDP Industries, Inc. is pleased to offer our quotation **AS THE BASIS OF DESIGN** for one (1) 3DP Belt Filter Press and accessories. The belt press will process 250 GPM at a 1% with expected cake solids of 17% at a polymer dosage of 24# per dry ton of active polymer. The belt press will be designed to dewater solids from 100% waste activated sludge treatment process as required. Below is a summary of our scope of work.

EQUIPMENT DESCRIPTION

The 3DP equipment package includes one complete belt filter press and appurtenant equipment described as follows:

1. One (1) 316L stainless steel polymer injection and polymer/sludge mixing systems consisting of an injection ring, variable vortex mixer and reducing fittings.
2. One (1) 2.0 meter 3DP, **3-belt**, belt filter press with the following design features:
 - a.) Structural steel frame per **ASTM A500**.
 - b.) Hot Dipped Galvanized coating per ASTM 123.
 - c.) Frame safety factor of 10 at 70 PLI.
 - d.) Polyurethane clear coat gravity zone slide decks and wedge zone.
 - e.) Machined bearing pads.
 - f.) Up-flow feedbox.
 - g.) Variable speed **paddle distributor** wheel for feedbox with 1/3 HP drive.
 - h.) Twelve foot **independent**, variable speed gravity section at operator level.
 - i.) 1/4" x 3" stainless steel gravity deck support spaced every 6 inches.
 - j.) Eight (8) rows of adjustable, furrowing plows with HDG steel support bars.
 - k.) Curved wedge section.
 - l.) 316 stainless steel, 24" diameter, perforated roller.
 - m.) Eight s-wrap pressure section.



354 State Route 29, Greenwich, New York 12834
Phone No 518-695-6851
E-mail: aj@bdpindustries.com

- n.) UHMW scraper blades.
 - o.) Nylon covered rollers.
 - p.) 316 stainless steel wetted parts.
 - q.) 316 stainless steel hardware.
 - r.) **70 PLI** hydraulic tensioning and tracking.
 - s.) **Dual shaft mounted** pressure section drives for the upper and lower belts.
 - t.) Stainless steel Rack and Pinion tensioning in the pressure section.
 - u.) Corrosion resistant composite cylinders with 316 stainless steel rods and stainless steel hardware.
 - v.) Self-cleaning, adjustable angle belt showers with Victaulic connections.
 - w.) Dodge, closed end, split case bearings rated for **1,000,000 hours at 70 PLI** at 15 ft/min.
 - x.) Nylon coated bearings.
 - y.) Bearing flingers.
 - z.) TEFC, IP 65 severe duty variable speed motors.
 - aa.) Aluminum conduit.
 - bb.) Zero speed switches for the gravity and press belts.
 - cc.) 316 stainless steel NEMA 4X low voltage junction box.
 - dd.) 460/3/60
3. One (1) complete NEMA 4X, wall mount, 304 stainless steel, NEMA 4X, electrical control panels for all the dewatering system control functions and drives. The PLC based panels shall contain all interlocks and controls for the belt press, polymer systems, sludge pumps, booster pumps, hydraulic units, discharge conveyors, and press mounted drives. The control panel shall include Allen Bradley Power Flex series variable frequency drives, Allen Bradley Panelview Plus 7 12" color OIT, Stratix 8000 Ethernet switch, and Allen Bradley Compact Logic PLC controls. The VFDs for the sludge pumps will be supplied by others. The control panel will include air conditioner and redundant pushbuttons on the door identical to the existing press.
4. One (1) 2 hp hydraulic power unit with a 20-gallon, 316 stainless steel reservoir.
5. One (1) 25 HP Goulds model 3196 wash water booster pump capable of boosting from 30 to 120 PSI at a flow rate of 200 GPM. The filtrate wash water system will include water pressure gauge with diaphragm seal and electric full port ball valve as specified.



354 State Route 29, Greenwich, New York 12834

Phone No 518-695-6851

E-mail: aj@bdpindustries.com

6. One (1) lot of spare parts as specified in section 1.09.
7. All start-up, mechanical checkout and operator training as specified. Service to include three separate trips with 8 days of on-site services.
8. One year machine warranty.
9. Freight to the jobsite

The model 3DP belt press will come completely factory-assembled, tested and will be shipped in two pieces. The polymer injection device, hydraulic unit, belt media, booster pump, polymer system and electrical control panels will be packed separately. This quotation is for furnishing equipment only and does not include any other installation labor or field services other than checkout, start up and testing services as listed above. All installation, on-site assembly, anchorage, pads and other work required to facilitate the setting of the equipment is to be by others. All labor and material for interconnecting between the press and the auxiliary equipment is to be completed by others.

SUBMITTAL DATA

Submittals will be made in the number of copies specified and will be available within 4 to 8 weeks after firm purchase order and all information is received at the factory.

SHIPMENT

Approximate shipping weight of the unit is 27,000 pounds. Estimated shipping time is 20 to 26 weeks after receipt of submittal approval.

FIELD SERVICE

Installation observation, testing and operator instruction services as listed above will be supplied. Additional service can be supplied at a service rate of \$1,000 per day plus travel expenses.

PRICING

The price for the above scope of supply is \$377,000.00. (US Dollars).

see comment on next page

This price includes the shipping cost to the job site or nearest unloading point. The price does not include unloading cost and applicable taxes of any kind. This quotation will be valid for sixty (60) days from the date of this proposal.



354 State Route 29, Greenwich, New York 12834
 Phone No 518-695-6851
 E-mail: aj@bdpindustries.com

TERMS

Terms of payment are 90% upon shipment of equipment and 10% upon start up.

We appreciate this opportunity to extend our quotation. If we can answer questions, please do not hesitate to contact our local representative:

Eric Jordan or Fred Nugent at FJ Nugent & Associates at (407) 936-1139

Sincerely,

A.J. Schmidt
 BDP Industries, Inc.

cc: Dan Fronhofer, BDP Industries, Inc.

Eric Jordan
386-225-5250 cell
407-936-1139 office
eric@nugentco.com



**ODP PURCHASE ORDER NEEDS TO BE
 ISSUED FOR FOLLOWING
 EQUIPMENT PRICE - \$377,000
 FREIGHT - INCLUDED
 Site Services - INCLUDED
 TOTAL - \$377,000**

**DEDUCTION FROM WHARTON-SMITH
 EQUIPMENT PRICE - \$377,000
 TAX - \$ 22,620
 SURTAX - .25
 FREIGHT - INCLUDED
 Site Services - INCLUDED
 TOTAL - \$399645**

CONDITIONS OF SALE - COS 5-86

TOTAL TAX SAVING - \$22,645

1.1. General -

This contract will exist between BDP Industries, Inc. (hereafter referred to as BDP) and the buyer only when accepted in writing by an officer of BDP. The prices quoted herein are firm for a period of 60 days if a contract is entered within thirty (30) days from the date on the face of this proposal. Any amendment to this contract must be in writing and acknowledged by both parties.

1.2. Terms of Payment -

Payment is to be made on a net basis within thirty (30) days after invoice, subject to credit approval by BDP. The buyer's payment obligation is not dependent upon the buyer's receipt of payment from any other party. BDP reserves the right to invoice on partial shipments. Any balance owed by the buyer beyond thirty (30) days or more after due is subject to delinquency charges of 1.5% per month or any fraction thereof. This shall be in addition to any other amounts due and buyer shall reimburse BDP for all collection costs, including attorney's fees BDP may incur with respect to collection of past due amounts from the buyer.

1.3. Taxes -

This proposal does not include any Federal, State or Local Sales, Privilege, Use or any other taxes of any kind applicable to the sale of the equipment covered under this agreement. The buyer shall pay these taxes or the buyer shall provide BDP with a tax exemption certificate applicable to proper taxing authority.



354 State Route 29, Greenwich, New York 12834
Phone No 518-695-6851
E-mail: aj@bdpindustries.com

1.4. Shipment –

All shipment will be F.O.B. factory. Shipping estimates contained herein are based on time of receipt at BDP's factory of all details pertaining to the order which are essential to contract completion.

1.5. Force Majeure –

BDP shall not be liable for any loss or damage of any nature whatsoever incurred or suffered as a result of any failures or delays in performance due to any cause or circumstances beyond its, or its subcontractors' or suppliers' control, including, but not by way of limitation, failure or delays in performance caused by strikes, lockouts or labor disputes, acts of purchaser, fires, acts of God or the public enemy, riots, incendiaries, interferences by civil or military authorities, compliance with the laws of the United States or with the orders or policies of any Governmental authority, delays in transit or delivery on the part of transportation companies or communication facilities or failure of sources of raw material. In the event of such delay, the time of delivery or completion shall be extended by a period of time equal to the period of delay plus such time as needed for start-up and/or remobilization, provided however, should the Force Majeure situation extend beyond six months the contract may be canceled by either party. Purchaser shall reimburse BDP for all costs and expenses including overhead costs which BDP may have reasonably incurred in terminating the contract, plus an amount as reasonable profits on that portions to the contract which has been completed.

1.6. Warranty –

BDP warrants the equipment manufactured by it to be free from defects in materials and workmanship for a period of 12-months from the date of shipment or 18 months from the date of start-up, whichever occurs first. BDP will repair or replace, at its option, F.O.B. its factory, any defective part or material, provided prompt notification is rendered in writing. The repair or replacement of items such as light bulbs, grease, oil, drive belts or chains, pump seals, etc. are not covered by this warranty and are considered normal consumption and routine maintenance items. In addition to the replacement of defective parts, BDP will also provide such labor as it deems necessary, to repair a defect in the main frame structure. BDP will not assume the cost of any modification or repair of its equipment unless it specifically gives authority for such action. THIS WARRANTY IS EXCLUSIVE AND IN LIEU OF ALL OTHERS. BDP MAKES NO WARRANTY AS TO FITNESS OF ITS PRODUCTS FOR PARTICULAR PURPOSE OR MERCHANTABILITY.

1.7. Limitation of Liability –

In no event, be it due to breach of any warranty hereunder or any other cause rising out of performance or non-performance of the obligations herein, whether any such breach or cause be or sound in tort, contract or otherwise, shall BDP be liable for:

- a) Indirect, special or consequential damages (such as, but not limited to, loss of profits, plant downtime, fines, penalties, or cost of replacement services) or sued by third parties against the purchaser (excluding suits regarding patents on title to the goods furnished hereunder).
- b) BDP's total cumulative liability for any and all reasons, shall not exceed an amount equal to the contract price.

1.8. Claims –

The buyer shall immediately inspect equipment within ten (10) days after receipt, BDP is not obligated to consider any claim for shortages or non-conformance unless notified by the buyer within ten (10) days after his receipt of the goods in question, BDP is not responsible for loss or damage in transit, however they will lend any possible assistance to the buyer in his pursuit of claim recovery.

1.9. Cancellation –

BDP will accept cancellation of this order upon receipt of payment for percentage of the contract equal to a percentage of the work completed. This shall be, at a minimum, 20% of the contract price.

1.10. Storage –

If the buyer delays shipment, then the buyer agrees to pay all invoices as they become due. The buyer further agrees to pay, in addition, storage charges computed at 1.5% per month of the invoice price of equipment stored.



354 State Route 29, Greenwich, New York 12834

Phone No 518-695-6851

E-mail: aj@bdpindustries.com

1.11. Permits –

The buyer shall assume full cost and responsibility to obtain all permits or licenses with respect to the installation and operation of the equipment covered under this agreement. This shall include all requirements by Federal, State and Local governmental bodies.

This contract shall be governed in accordance with the laws of the State of New York. These conditions and terms are the only terms and conditions that will be binding upon the parties unless amended, and acknowledged, in writing by both parties. No assignment of this proposal or any purchase order resulting here from shall be binding on BDP unless accepted in writing by BDP.

CONTRACT AMENDMENT NO. 1

THIS CONTRACT AMENDMENT NO. 1 (Amendment) to the Agreement between St. Johns County (Owner), a political subdivision of the State of Florida, and Wharton-Smith (Contractor), for construction of Bid No. 17-63, Players Club Water Reclamation Facility is made and entered into. In consideration of the mutual promises and covenants set forth herein, the parties hereby agree as follows:

1. **Contract Price.** Article 5, subsection 5.01, paragraph A is hereby amended to reduce the lump sum price from thirty two million five hundred fifty five thousand seven hundred dollars and 00/100 (\$32,555,700) to twenty six million seven hundred twenty eight thousand two hundred sixty five dollars and 16/100 (\$26,728,265.16). The total of all extended prices for unit price work in Article 5, subsection 5.02 remains unchanged. The total lump sum and unit price work in Article 5, subsection 5.03 is hereby amended to twenty six million nine hundred fifty thousand five hundred sixty five dollars and 16/100 (\$26,950,565.16).

2. **Entire Agreement.** Both the Owner and the Contractor acknowledge that this Amendment constitutes the complete agreement and understanding of the parties regarding this first amendment to the Contract Price included in the Agreement, and supersedes and cancels all previous oral and/or written communications, proposals, agreements and commitments. All subsequent amendments to the Agreement shall be authorized by Change Order as provided in the Agreement.

3. **Effect of this Amendment.** With the exception of the changes, amendments, modifications, and revisions to the Contract Price provided herein, all remaining provisions contained in the Agreement shall remain in full force and effect. The Owner and the Contractor hereby acknowledge that any further change, amendment, modification or revision of the Agreement shall be in writing, and shall be executed by duly authorized representatives of each party.

IN WITNESS WHEREOF, the Owner and the Contractor have caused this Amendment to the Agreement to be duly executed as of the date of full execution set forth below.

OWNER

By: _____

Title: _____

Date: _____

CONTRACTOR

By: _____

Title: _____

Date: _____

**AGREEMENT
BETWEEN OWNER AND CONTRACTOR
FOR CONSTRUCTION CONTRACT (STIPULATED PRICE)**

THIS AGREEMENT is by and between St. Johns County, Florida ("Owner"), a political subdivision of the State of Florida, whose principal offices are located at 500 San Sebastian View, St. Augustine, FL 32084, and Wharton-Smith, Inc. ("Contractor"), with offices located at 750 Monroe Road, Sanford, FL 32771, Phone: (407) 321-8410, Fax: (407) 327-6984, and Email: swhite@whartonsmith.com, under seal for Construction of **Bid No: 17-63, Players Club Water Reclamation Facility**. The Owner and Contractor hereby agree as follows:

Article 1. WORK

- 1.01 Contractor shall complete all Work as specified or indicated in the Contract Documents. The Work is generally described as follows:
- A. The construction of the 2.4 MGD Players Club Water Reclamation Facility project requires contractor to furnish all labor, materials, equipment, incidentals required to construct new facilities and equipment to serve as an advanced wastewater treatment facility with a rated capacity of 2.4 million gallons per day on an annual average day basis. The project will be constructed on an active wastewater treatment plant (WWTP) site and existing WWTP operation shall be maintained until commissioning of the new facility. The scope of work includes but is not limited to all new processes, equipment, buildings, pipelines and appurtenances, site work, paving, grading, drainage, demolition of the existing wastewater treatment plant facility, testing, allowances, and permitting all in accordance with the Contract Documents. A detailed scope of work including all bid items can be found in the bid documents. This project is funded through a State Revolving Fund Loan and shall be subject to all Federal-Contract Requirements as provided in the Florida Department of Environmental Protection Supplementary Conditions contained in the bid documents.

Article 2. PROJECT

- 2.01 The Project, of which the Work under the Contract Documents is a part, is generally described as follows:
- A. Bid No. 17 - 63; Players Club Water Reclamation Facility, Ponte Vedra, Florida

Article 3. ENGINEER

- 3.01 The Project has been designed by Mott MacDonald Florida LLC, 10245 Centurion Parkway, Suite 320, Jacksonville, Florida, 32256.
- 3.02 The Owner has retained Mott MacDonald Florida LLC, 10245 Centurion Parkway, Suite 320, Jacksonville, Florida, 32256 ("Engineer") to act as Owner's Representative, assume all duties and responsibilities, and have the rights and authority assigned to Engineer in

the Contract Documents in connection with the completion of the Work in accordance with the Contract Documents.

Article 4. CONTRACT TIMES

4.01 Time of the Essence

- A. All time limits for Milestones, if any, Substantial Completion, and completion and readiness for final payment as stated in the Contract Documents are of the essence of the Contract.

4.02 Contract Times: Days.

- A. The Work of Phase 1 will be substantially completed within **Eight Hundred Ten (810)** consecutive days after the date when the Contract Times commence, the Work of Phase 2 will be substantially completed within **Eight Hundred Seventy (870)** consecutive days after the date when the Contract Times commence and both will run as provided in Paragraph 4.01 of the General Conditions, and completed and ready for final payment in accordance with Paragraph 15.06 of the General Conditions within **Thirty (30)** days after Phase 2 Substantial Completion.

4.03 Liquidated Damages

- A. Contractor and Owner recognize that time is of the essence as stated in Paragraph 4.01 above and that Owner will suffer financial and other losses if the Work is not completed and Milestones not achieved within the times specified in Paragraph 4.02 above, plus any extensions thereof allowed in accordance with the Contract. The parties also recognize the delays, expense, and difficulties involved in proving in a legal or arbitration proceeding the actual loss suffered by Owner if the Work is not completed on time. Accordingly, instead of requiring any such proof, Owner and Contractor agree that as liquidated damages for delay (but not as a penalty):
1. Phase 1 Substantial Completion: Contractor shall pay Owner **\$3,800** for each day that expires after the time (as duly adjusted pursuant to the Contract) specified in Paragraph 4.02.A above for Phase 1 Substantial Completion until the Work is substantially complete.
 2. Phase 2 Substantial Completion: Contractor shall pay Owner **\$2,600** for each day that expires after the time (as duly adjusted pursuant to the Contract) specified in Paragraph 4.02.A above for Phase 2 Substantial Completion until the Work is substantially complete.
 3. Completion of Remaining Work: After Phase 2 Substantial Completion, if Contractor shall neglect, refuse, or fail to complete the remaining Work within the Contract Time (as duly adjusted pursuant to the Contract) for completion and readiness for final payment, Contractor shall pay Owner **\$1,400** for each day that expires after such time until the Work is completed and ready for final payment.
 4. Liquidated damages for failing to timely attain Substantial Completion and final completion are not additive and will not be imposed concurrently.

4.04 Special Damages

- A. In addition to the amount provided for liquidated damages, Contractor shall

reimburse Owner (1) for any fines or penalties imposed on Owner as a direct result of the Contractor's failure to attain Substantial Completion according to the Contract Times, and (2) for the actual costs reasonably incurred by Owner for engineering, construction observation, inspection, and administrative services needed after the time specified in Paragraph 4.02 for Substantial Completion (as duly adjusted pursuant to the Contract), until the Work is substantially complete

- B. After Contractor achieves Substantial Completion, if Contractor shall neglect, refuse, or fail to complete the remaining Work within the Contract Times, Contractor shall reimburse Owner for the actual costs reasonably incurred by Owner for engineering, construction observation, inspection, and administrative services needed after the time specified in Paragraph 4.02 for Work to be completed and ready for final payment (as duly adjusted pursuant to the Contract), until the Work is completed and ready for final payment.

Article 5. CONTRACT PRICE

5.01 Owner shall pay Contractor for completion of the Work in accordance with the Contract Documents the amounts that follow, subject to adjustment under the Contract:

- A. For all Work other than Unit Price Work, a lump sum of:

Thirty-two million Five Hundred Fifty-five Thousand Seven Hundred dollars (\$32,555,700.00).

All specific cash allowances are included in the above price in accordance with Paragraph 13.02 of the General Conditions.

5.02 For all Unit Price Work, an amount equal to the sum of the extended prices (established for each separately identified item of Unit Price Work by multiplying the unit price times the actual quantity of that item):

Unit Price Work					
Item No.	Description	Unit	Estimated Quantity	Unit Price	Extended Price
8	Milling for Entry Road	SY	6,000	\$3.00	\$18,000.00
9	Asphalt resurface of Entry Road	Ton	495	\$140.00	\$69,300.00
11	Grit/Debris/Sludge Removal	CY	750	\$180.00	\$135,000.00
Total of all Extended Prices for Unit Price Work (subject to final adjustment based on actual quantities)					\$222,300.00

5.03 Total of Lump Sum Amount and Unit Price Work (subject to final Unit Price adjustment)

Thirty-two million Seven Hundred Seventy-eight Thousand dollars (\$32,778,000.00).

5.04 For all Work, at the prices stated in Contractor's Bid, attached hereto as an exhibit.

Article 6. PAYMENT PROCEDURES

6.01 Submittal and Processing of Payments

A. Contractor shall submit Applications for Payment in accordance with Article 15 of the General Conditions. Applications for Payment will be processed by Engineer as provided in the General Conditions.

6.02 Progress Payments; Retainage

A. Owner shall make progress payments on account of the Contract Price on the basis of Contractor's Applications for Payment on or about the day of each month during performance of the Work as provided in Paragraph 6.02.A.1 below, provided that such Applications for Payment have been submitted in a timely manner and otherwise meet the requirements of the Contract. All such payments will be measured by the Schedule of Values established as provided in the General Conditions (and in the case of Unit Price Work based on the number of units completed) or, in the event there is no Schedule of Values, as provided elsewhere in the Contract.

1. Prior to Phase 1 Substantial Completion, progress payments will be made in an amount equal to the percentage indicated below but, in each case, less the aggregate of payments previously made and less such amounts as Owner may withhold, including but not limited to liquidated damages, in accordance with the Contract:

- a. Ninety (90%) percent of Work completed (with the balance being retainage). If the Work has been 50 percent completed as determined by Engineer, and if the character and progress of the Work have been satisfactory to Owner and Engineer, then as long as the character and progress of the Work remain satisfactory to Owner and Engineer, there will be no additional retainage; and
- b. Fifty (50%) percent of cost of materials and equipment not incorporated in the Work (with the balance being retainage).

B. Upon Phase 2 Substantial Completion, Owner shall pay an amount sufficient to increase total payments to Contractor to One Hundred (100%) percent of the Work completed, less such amounts set off by Owner pursuant to Paragraph 15.01.E of the General Conditions, and less Two Hundred (200%) percent of Engineer's estimate of the value of Work to be completed or corrected as shown on the punch list of items to be completed or corrected prior to final payment.

6.03 Final Payment

A. Upon final completion and acceptance of the Work in accordance with Paragraph 15.06 of the General Conditions, Owner shall pay the remainder of the Contract Price as recommended by Engineer as provided in said Paragraph 15.06.

Article 7. INTEREST

7.01 All amounts not paid when due shall bear interest at the rate of Zero (0.00) percent per annum

Article 8. CONTRACTOR'S REPRESENTATIONS

8.01 In order to induce Owner to enter into this Contract, Contractor makes the following representations

- A. Contractor has examined and carefully studied the Contract Documents, and any data and reference items identified in the Contract Documents.
- B. Contractor has visited the Site, conducted a thorough, alert visual examination of the Site and adjacent areas, and become familiar with and is satisfied as to the general, local, and Site conditions that may affect cost, progress, and performance of the Work.
- C. Contractor is familiar with and is satisfied as to all Laws and Regulations that may affect cost, progress, and performance of the Work.
- D. Contractor has carefully studied all: (1) reports of explorations and tests of subsurface conditions at or adjacent to the Site and all drawings of physical conditions relating to existing surface or subsurface structures at the Site that have been identified in the Supplementary Conditions, especially with respect to Technical Data in such reports and drawings, and (2) reports and drawings relating to Hazardous Environmental Conditions, if any, at or adjacent to the Site that have been identified in the Supplementary Conditions, especially with respect to Technical Data in such reports and drawings.
- E. Contractor has considered the information known to Contractor itself; information commonly known to contractors doing business in the locality of the Site; information and observations obtained from visits to the Site; the Contract Documents; and the Site-related reports and drawings identified in the Contract Documents, with respect to the effect of such information, observations, and documents on (1) the cost, progress, and performance of the Work; (2) the means, methods, techniques, sequences, and procedures of construction to be employed by Contractor; and (3) Contractor's safety precautions and programs.
- F. Based on the information and observations referred to in the preceding paragraph, Contractor agrees that no further examinations, investigations, explorations, tests, studies, or data are necessary for the performance of the Work at the Contract Price, within the Contract Times, and in accordance with the other terms and conditions of the Contract.
- G. Contractor is aware of the general nature of work to be performed by Owner and others at the Site that relates to the Work as indicated in the Contract Documents.
- H. Contractor has given Engineer written notice of all conflicts, errors, ambiguities, or discrepancies that Contractor has discovered in the Contract Documents, and the written resolution thereof by Engineer is acceptable to Contractor.

- I. The Contract Documents are generally sufficient to indicate and convey understanding of all terms and conditions for performance and furnishing of the Work.
- J. Contractor's entry into this Contract constitutes an incontrovertible representation by Contractor that without exception all prices in the Agreement are premised upon performing and furnishing the Work required by the Contract Documents.

Article 9. CONTRACT DOCUMENTS

9.01 Contents:

- A. The Contract Documents consist of the following:
 1. This Agreement (pages 1 to 9, inclusive).
 2. Public construction bond (pages 1 to 2, inclusive).
 3. General Conditions (pages 1 to 65, inclusive).
 4. Supplementary Conditions (pages 1 to 12, inclusive).
 5. FDEP Supplementary Conditions (Construction) including Wage Decision FL178 (pages 1 to 25, inclusive).
 6. Specifications as listed in the table of contents of the Project Manual.
 7. Drawings (not attached but incorporated by reference) consisting of 265 sheets with each sheet bearing the following general title: Players Club Water Reclamation Facility, Ponte Vedra, Florida
 8. Addenda (numbers 1 to 4, inclusive)
 9. Exhibits to this Agreement (enumerated as follows):
 - a. Contractor's Bid (pages 1 to 98, inclusive).
 10. The following which may be delivered or issued on or after the Effective Date of the Contract and are not attached hereto:
 - a. Notice to Proceed.
 - b. Work Change Directives.
 - c. Change Orders.
 - d. Field Orders.
- B. The documents listed in Paragraph 9.01.A are attached to this Agreement (except as expressly noted otherwise above).
- C. There are no Contract Documents other than those listed above in this Article 9.
- D. The Contract Documents may only be amended, modified, or supplemented as provided in the General Conditions.

Article 10. MISCELLANEOUS

10.01 Terms

- A. Terms used in this Agreement will have the meanings stated in the General Conditions and the Supplementary Conditions.

10.02 Assignment of Contract

- A. Unless expressly agreed to elsewhere in the Contract, no assignment by a party hereto of any rights under or interests in the Contract will be binding on another party hereto without the written consent of the party sought to be bound; and, specifically but without limitation, money that may become due and money that is due may not be assigned without such consent (except to the extent that the effect of this restriction may be limited by law), and unless specifically stated to the contrary in any written consent to an assignment, no assignment will release or discharge the assignor from any duty or responsibility under the Contract Documents.

10.03 Successors and Assigns

- A. Owner and Contractor each binds itself, its successors, assigns, and legal representatives to the other party hereto, its successors, assigns, and legal representatives in respect to all covenants, agreements, and obligations contained in the Contract Documents.

10.04 Severability

- A. Any provision or part of the Contract Documents held to be void or unenforceable under any Law or Regulation shall be deemed stricken, and all remaining provisions shall continue to be valid and binding upon Owner and Contractor, who agree that the Contract Documents shall be reformed to replace such stricken provision or part thereof with a valid and enforceable provision that comes as close as possible to expressing the intention of the stricken provision.

10.05 Contractor's Certifications

- A. Contractor certifies that it has not engaged in corrupt, fraudulent, collusive, or coercive practices in competing for or in executing the Contract. For the purposes of this Paragraph 10.05:
 1. "corrupt practice" means the offering, giving, receiving, or soliciting of any thing of value likely to influence the action of a public official in the bidding process or in the Contract execution;
 2. "fraudulent practice" means an intentional misrepresentation of facts made (a) to influence the bidding process or the execution of the Contract to the detriment of Owner, (b) to establish Bid or Contract prices at artificial non-competitive levels, or (c) to deprive Owner of the benefits of free and open competition;
 3. "collusive practice" means a scheme or arrangement between two or more Bidders, with or without the knowledge of Owner, a purpose of which is to establish Bid prices at artificial, non-competitive levels; and
 4. "coercive practice" means harming or threatening to harm, directly or indirectly, persons or their property to influence their participation in the bidding process or affect the execution of the Contract.

10.06 Other Provisions

A. Owner stipulates that if the General Conditions that are made a part of this Contract are based on EJCDC® C-700, Standard General Conditions for the Construction Contract, published by the Engineers Joint Contract Documents Committee®, and if Owner is the party that has furnished said General Conditions, then Owner has plainly shown all modifications to the standard wording of such published document to the Contractor, through a process such as highlighting or "track changes" (redline/strikeout), or in the Supplementary Conditions.

ST JOHNS COUNTY

NOV 13 '17

PURCHASING

IN WITNESS WHEREOF, Owner and Contractor have signed this Agreement.

This Agreement will be effective November 14, 2017 (which is the Effective Date of the Contract).

OWNER:

CONTRACTOR:

St. Johns County, FL

Wharton-Smith, Inc.

By: *Jaime Locklear*
Signature of Authorized Representative

(Typed Name)
By: *Ronald K. Davoli*
Signature of Authorized Representative

Jaime T. Locklear, MPA, CPPB, FCCM
Print Name
Assistant Purchasing Manager
Title

Ronald K. Davoli
Print Name
Pres. Joint S.C.C.
Title

11/14/17
Date of Execution:

November 9, 2017
Date of Execution:

ATTEST:

Attest: *Debra Jenkins*

St. Johns County, FL
Clerk of Courts

Title: Corporate Secretary

By: *Stephanie M. [Signature]*
Title: Deputy Clerk

Legally Sufficient:

Mailing Address for giving notices:

Stephanie M. [Signature]
Deputy County Attorney
10/24/17
Date of Execution

P.O. BOX 471028
LAKE MONROE, FL 32747

Mailing Address for giving notices:

500 San Sebastian View
St. Augustine, FL 32084

License No.: CGC 1011243

This document has important legal consequences; consultation with an attorney is encouraged with respect to its use or modification. This document should be adapted to the particular circumstances of the contemplated Project and the controlling Laws and Regulations.

STANDARD GENERAL CONDITIONS OF THE CONSTRUCTION CONTRACT

Prepared by



Issued and Published Jointly by



Endorsed by



These General Conditions have been prepared for use with the Agreement Between Owner and Contractor for Construction Contract (EJCDC® C-520, Stipulated Sum, or C-525, Cost-Plus, 2013 Editions). Their provisions are interrelated and a change in one may necessitate a change in the other.

To prepare supplementary conditions that are coordinated with the General Conditions, use EJCDC's Guide to the Preparation of Supplementary Conditions (EJCDC® C-800, 2013 Edition). The full EJCDC Construction series of documents is discussed in the Commentary on the 2013 EJCDC Construction Documents (EJCDC® C-001, 2013 Edition).

Copyright © 2013:

National Society of Professional Engineers
1420 King Street, Alexandria, VA 22314-2794
(703) 684-2882
www.nspe.org

American Council of Engineering Companies
1015 15th Street N.W., Washington, DC 20005
(202) 347-7474
www.acec.org

American Society of Civil Engineers
1801 Alexander Bell Drive, Reston, VA 20191-4400
(800) 548-2723
www.asce.org

The copyright for this document is owned jointly by the three sponsoring organizations listed above. The National Society of Professional Engineers is the Copyright Administrator for the EJCDC documents; please direct all inquiries regarding EJCDC copyrights to NSPE.

NOTE: EJCDC publications may be purchased at www.ejcdc.org, or from any of the sponsoring organizations above.

STANDARD GENERAL CONDITIONS OF THE CONSTRUCTION CONTRACT

TABLE OF CONTENTS

	Page
Article 1 – Definitions and Terminology	1
1.01 Defined Terms	1
1.02 Terminology.....	5
Article 2 – Preliminary Matters.....	6
2.01 Delivery of Bonds and Evidence of Insurance	6
2.02 Copies of Documents.....	6
2.03 Before Starting Construction	6
2.04 Preconstruction Conference; Designation of Authorized Representatives.....	7
2.05 Initial Acceptance of Schedules	7
2.06 Electronic Transmittals	7
Article 3 – Documents; Intent, Requirements, Reuse	8
3.01 Intent	8
3.02 Reference Standards.....	8
3.03 Reporting and Resolving Discrepancies.....	8
3.04 Requirements of the Contract Documents.....	9
3.05 Reuse of Documents.....	10
Article 4 – Commencement and Progress of the Work.....	10
4.01 Commencement of Contract Times; Notice to Proceed.....	10
4.02 Starting the Work	10
4.03 Reference Points.....	10
4.04 Progress Schedule.....	10
4.05 Delays in Contractor’s Progress.....	11
Article 5 – Availability of Lands; Subsurface and Physical Conditions; Hazardous Environmental Conditions	12
5.01 Availability of Lands	12
5.02 Use of Site and Other Areas	12
5.03 Subsurface and Physical Conditions	13
5.04 Differing Subsurface or Physical Conditions.....	14
5.05 Underground Facilities	15

5.06	Hazardous Environmental Conditions at Site	17
Article 6 – Bonds and Insurance		19
6.01	Performance, Payment, and Other Bonds.....	19
6.02	Insurance—General Provisions.....	19
6.03	Contractor’s Insurance	20
6.04	Owner’s Liability Insurance.....	23
6.05	Property Insurance	23
6.06	Waiver of Rights.....	25
6.07	Receipt and Application of Property Insurance Proceeds	25
Article 7 – Contractor’s Responsibilities		26
7.01	Supervision and Superintendence.....	26
7.02	Labor; Working Hours.....	26
7.03	Services, Materials, and Equipment.....	26
7.04	“Or Equals”	27
7.05	Substitutes	28
7.06	Concerning Subcontractors, Suppliers, and Others.....	29
7.07	Patent Fees and Royalties.....	31
7.08	Permits.....	31
7.09	Taxes	32
7.10	Laws and Regulations	32
7.11	Record Documents	32
7.12	Safety and Protection	32
7.13	Safety Representative.....	33
7.14	Hazard Communication Programs.....	33
7.15	Emergencies.....	34
7.16	Shop Drawings, Samples, and Other Submittals	34
7.17	Contractor’s General Warranty and Guarantee	36
7.18	Indemnification.....	37
7.19	Delegation of Professional Design Services.....	37
Article 8 – Other Work at the Site		38
8.01	Other Work.....	38
8.02	Coordination.....	39
8.03	Legal Relationships	39

Article 9 – Owner’s Responsibilities.....	40
9.01 Communications to Contractor	40
9.02 Replacement of Engineer	40
9.03 Furnish Data.....	40
9.04 Pay When Due	40
9.05 Lands and Easements; Reports, Tests, and Drawings.....	40
9.06 Insurance	40
9.07 Change Orders	40
9.08 Inspections, Tests, and Approvals	41
9.09 Limitations on Owner’s Responsibilities.....	41
9.10 Undisclosed Hazardous Environmental Condition	41
9.11 Evidence of Financial Arrangements	41
9.12 Safety Programs.....	41
Article 10 – Engineer’s Status During Construction.....	41
10.01 Owner’s Representative	41
10.02 Visits to Site	41
10.03 Project Representative	42
10.04 Rejecting Defective Work	42
10.05 Shop Drawings, Change Orders and Payments	42
10.06 Determinations for Unit Price Work.....	42
10.07 Decisions on Requirements of Contract Documents and Acceptability of Work.....	42
10.08 Limitations on Engineer’s Authority and Responsibilities	42
10.09 Compliance with Safety Program	43
Article 11 – Amending the Contract Documents; Changes in the Work	43
11.01 Amending and Supplementing Contract Documents.....	43
11.02 Owner-Authorized Changes in the Work.....	44
11.03 Unauthorized Changes in the Work	44
11.04 Change of Contract Price	44
11.05 Change of Contract Times	45
11.06 Change Proposals	45
11.07 Execution of Change Orders	46
11.08 Notification to Surety	47
Article 12 – Claims.....	47

12.01	Claims.....	47
Article 13	– Cost of the Work; Allowances; Unit Price Work.....	48
13.01	Cost of the Work.....	48
13.02	Allowances.....	50
13.03	Unit Price Work.....	51
Article 14	– Tests and Inspections; Correction, Removal or Acceptance of Defective Work.....	52
14.01	Access to Work	52
14.02	Tests, Inspections, and Approvals	52
14.03	Defective Work	53
14.04	Acceptance of Defective Work.....	53
14.05	Uncovering Work.....	53
14.06	Owner May Stop the Work.....	54
14.07	Owner May Correct Defective Work	54
Article 15	– Payments to Contractor; Set-Offs; Completion; Correction Period	55
15.01	Progress Payments	55
15.02	Contractor’s Warranty of Title.....	58
15.03	Substantial Completion	58
15.04	Partial Use or Occupancy.....	59
15.05	Final Inspection.....	59
15.06	Final Payment	59
15.07	Waiver of Claims.....	61
15.08	Correction Period.....	61
Article 16	– Suspension of Work and Termination	62
16.01	Owner May Suspend Work.....	62
16.02	Owner May Terminate for Cause	62
16.03	Owner May Terminate For Convenience.....	63
16.04	Contractor May Stop Work or Terminate.....	63
Article 17	– Final Resolution of Disputes	64
17.01	Methods and Procedures	64
Article 18	– Miscellaneous	64
18.01	Giving Notice.....	64
18.02	Computation of Times	64
18.03	Cumulative Remedies	64

18.04 Limitation of Damages..... 65
18.05 No Waiver..... 65
18.06 Survival of Obligations..... 65
18.07 Controlling Law..... 65
18.08 Headings 65

ARTICLE 1 – DEFINITIONS AND TERMINOLOGY

1.01 *Defined Terms*

- A. Wherever used in the Bidding Requirements or Contract Documents, a term printed with initial capital letters, including the term's singular and plural forms, will have the meaning indicated in the definitions below. In addition to terms specifically defined, terms with initial capital letters in the Contract Documents include references to identified articles and paragraphs, and the titles of other documents or forms.
1. *Addenda*—Written or graphic instruments issued prior to the opening of Bids which clarify, correct, or change the Bidding Requirements or the proposed Contract Documents.
 2. *Agreement*—The written instrument, executed by Owner and Contractor, that sets forth the Contract Price and Contract Times, identifies the parties and the Engineer, and designates the specific items that are Contract Documents.
 3. *Application for Payment*—The form acceptable to Engineer which is to be used by Contractor during the course of the Work in requesting progress or final payments and which is to be accompanied by such supporting documentation as is required by the Contract Documents.
 4. *Bid*—The offer of a Bidder submitted on the prescribed form setting forth the prices for the Work to be performed.
 5. *Bidder*—An individual or entity that submits a Bid to Owner.
 6. *Bidding Documents*—The Bidding Requirements, the proposed Contract Documents, and all Addenda.
 7. *Bidding Requirements*—The advertisement or invitation to bid, Instructions to Bidders, Bid Bond or other Bid security, if any, the Bid Form, and the Bid with any attachments.
 8. *Change Order*—A document which is signed by Contractor and Owner and authorizes an addition, deletion, or revision in the Work or an adjustment in the Contract Price or the Contract Times, or other revision to the Contract, issued on or after the Effective Date of the Contract.
 9. *Change Proposal*—A written request by Contractor, duly submitted in compliance with the procedural requirements set forth herein, seeking an adjustment in Contract Price or Contract Times, or both; contesting an initial decision by Engineer concerning the requirements of the Contract Documents or the acceptability of Work under the Contract Documents; challenging a set-off against payments due; or seeking other relief with respect to the terms of the Contract.
 10. *Claim*—(a) A demand or assertion by Owner directly to Contractor, duly submitted in compliance with the procedural requirements set forth herein: seeking an adjustment of Contract Price or Contract Times, or both; contesting an initial decision by Engineer concerning the requirements of the Contract Documents or the acceptability of Work under the Contract Documents; contesting Engineer's decision regarding a Change Proposal; seeking resolution of a contractual issue that Engineer has declined to address; or seeking other relief with respect to the terms of the Contract; or (b) a demand or assertion by Contractor directly to Owner, duly submitted in compliance with the procedural requirements set forth herein, contesting Engineer's decision regarding a Change Proposal; or seeking resolution of a contractual issue that Engineer

has declined to address. A demand for money or services by a third party is not a Claim.

11. *Constituent of Concern*—Asbestos, petroleum, radioactive materials, polychlorinated biphenyls (PCBs), hazardous waste, and any substance, product, waste, or other material of any nature whatsoever that is or becomes listed, regulated, or addressed pursuant to (a) the Comprehensive Environmental Response, Compensation and Liability Act, 42 U.S.C. §§9601 et seq. ("CERCLA"); (b) the Hazardous Materials Transportation Act, 49 U.S.C. §§5101 et seq.; (c) the Resource Conservation and Recovery Act, 42 U.S.C. §§6901 et seq. ("RCRA"); (d) the Toxic Substances Control Act, 15 U.S.C. §§2601 et seq.; (e) the Clean Water Act, 33 U.S.C. §§1251 et seq.; (f) the Clean Air Act, 42 U.S.C. §§7401 et seq.; or (g) any other federal, state, or local statute, law, rule, regulation, ordinance, resolution, code, order, or decree regulating, relating to, or imposing liability or standards of conduct concerning, any hazardous, toxic, or dangerous waste, substance, or material.
12. *Contract*—The entire and integrated written contract between the Owner and Contractor concerning the Work.
13. *Contract Documents*—Those items so designated in the Agreement, and which together comprise the Contract.
14. *Contract Price*—The money that Owner has agreed to pay Contractor for completion of the Work in accordance with the Contract Documents. .
15. *Contract Times*—The number of days or the dates by which Contractor shall: (a) achieve Milestones, if any; (b) achieve Substantial Completion; and (c) complete the Work.
16. *Contractor*—The individual or entity with which Owner has contracted for performance of the Work.
17. *Cost of the Work*—See Paragraph 13.01 for definition.
18. *Drawings*—The part of the Contract that graphically shows the scope, extent, and character of the Work to be performed by Contractor.
19. *Effective Date of the Contract*—The date, indicated in the Agreement, on which the Contract becomes effective.
20. *Engineer*—The individual or entity named as such in the Agreement.
21. *Field Order*—A written order issued by Engineer which requires minor changes in the Work but does not change the Contract Price or the Contract Times.
22. *Hazardous Environmental Condition*—The presence at the Site of Constituents of Concern in such quantities or circumstances that may present a danger to persons or property exposed thereto. The presence at the Site of materials that are necessary for the execution of the Work, or that are to be incorporated in the Work, and that are controlled and contained pursuant to industry practices, Laws and Regulations, and the requirements of the Contract, does not establish a Hazardous Environmental Condition.
23. *Laws and Regulations; Laws or Regulations*—Any and all applicable laws, statutes, rules, regulations, ordinances, codes, and orders of any and all governmental bodies, agencies, authorities, and courts having jurisdiction.

24. *Liens*—Charges, security interests, or encumbrances upon Contract-related funds, real property, or personal property.
25. *Milestone*—A principal event in the performance of the Work that the Contract requires Contractor to achieve by an intermediate completion date or by a time prior to Substantial Completion of all the Work.
26. *Notice of Award*—The written notice by Owner to a Bidder of Owner's acceptance of the Bid.
27. *Notice to Proceed*—A written notice by Owner to Contractor fixing the date on which the Contract Times will commence to run and on which Contractor shall start to perform the Work.
28. *Owner*—The individual or entity with which Contractor has contracted regarding the Work, and which has agreed to pay Contractor for the performance of the Work, pursuant to the terms of the Contract.
29. *Progress Schedule*—A schedule, prepared and maintained by Contractor, describing the sequence and duration of the activities comprising the Contractor's plan to accomplish the Work within the Contract Times.
30. *Project*—The total undertaking to be accomplished for Owner by engineers, contractors, and others, including planning, study, design, construction, testing, commissioning, and start-up, and of which the Work to be performed under the Contract Documents is a part.
31. *Project Manual*—The written documents prepared for, or made available for, procuring and constructing the Work, including but not limited to the Bidding Documents or other construction procurement documents, geotechnical and existing conditions information, the Agreement, bond forms, General Conditions, Supplementary Conditions, and Specifications. The contents of the Project Manual may be bound in one or more volumes.
32. *Resident Project Representative*—The authorized representative of Engineer assigned to assist Engineer at the Site. As used herein, the term Resident Project Representative or "RPR" includes any assistants or field staff of Resident Project Representative.
33. *Samples*—Physical examples of materials, equipment, or workmanship that are representative of some portion of the Work and that establish the standards by which such portion of the Work will be judged.
34. *Schedule of Submittals*—A schedule, prepared and maintained by Contractor, of required submittals and the time requirements for Engineer's review of the submittals and the performance of related construction activities.
35. *Schedule of Values*—A schedule, prepared and maintained by Contractor, allocating portions of the Contract Price to various portions of the Work and used as the basis for reviewing Contractor's Applications for Payment.
36. *Shop Drawings*—All drawings, diagrams, illustrations, schedules, and other data or information that are specifically prepared or assembled by or for Contractor and submitted by Contractor to illustrate some portion of the Work. Shop Drawings, whether approved or not, are not Drawings and are not Contract Documents.

37. *Site*—Lands or areas indicated in the Contract Documents as being furnished by Owner upon which the Work is to be performed, including rights-of-way and easements, and such other lands furnished by Owner which are designated for the use of Contractor.
38. *Specifications*—The part of the Contract that consists of written requirements for materials, equipment, systems, standards, and workmanship as applied to the Work, and certain administrative requirements and procedural matters applicable to the Work.
39. *Subcontractor*—An individual or entity having a direct contract with Contractor or with any other Subcontractor for the performance of a part of the Work.
40. *Substantial Completion*—The time at which the Work (or a specified part thereof) has progressed to the point where, in the opinion of Engineer, the Work (or a specified part thereof) is sufficiently complete, in accordance with the Contract Documents, so that the Work (or a specified part thereof) can be utilized for the purposes for which it is intended. The terms "substantially complete" and "substantially completed" as applied to all or part of the Work refer to Substantial Completion thereof.
41. *Successful Bidder*—The Bidder whose Bid the Owner accepts, and to which the Owner makes an award of contract, subject to stated conditions.
42. *Supplementary Conditions*—The part of the Contract that amends or supplements these General Conditions.
43. *Supplier*—A manufacturer, fabricator, supplier, distributor, materialman, or vendor having a direct contract with Contractor or with any Subcontractor to furnish materials or equipment to be incorporated in the Work by Contractor or a Subcontractor.
44. *Technical Data*—Those items expressly identified as Technical Data in the Supplementary Conditions, with respect to either (a) subsurface conditions at the Site, or physical conditions relating to existing surface or subsurface structures at the Site (except Underground Facilities) or (b) Hazardous Environmental Conditions at the Site. If no such express identifications of Technical Data have been made with respect to conditions at the Site, then the data contained in boring logs, recorded measurements of subsurface water levels, laboratory test results, and other factual, objective information regarding conditions at the Site that are set forth in any geotechnical or environmental report prepared for the Project and made available to Contractor are hereby defined as Technical Data with respect to conditions at the Site under Paragraphs 5.03, 5.04, and 5.06.
45. *Underground Facilities*—All underground pipelines, conduits, ducts, cables, wires, manholes, vaults, tanks, tunnels, or other such facilities or attachments, and any encasements containing such facilities, including but not limited to those that convey electricity, gases, steam, liquid petroleum products, telephone or other communications, fiber optic transmissions, cable television, water, wastewater, storm water, other liquids or chemicals, or traffic or other control systems.
46. *Unit Price Work*—Work to be paid for on the basis of unit prices.
47. *Work*—The entire construction or the various separately identifiable parts thereof required to be provided under the Contract Documents. Work includes and is the result of performing or providing all labor, services, and documentation necessary to produce such construction; furnishing, installing, and incorporating all materials and equipment into such construction; and may include related services such as testing, start-up, and commissioning, all as required by the Contract Documents.

48. *Work Change Directive*—A written directive to Contractor issued on or after the Effective Date of the Contract, signed by Owner and recommended by Engineer, ordering an addition, deletion, or revision in the Work.

1.02 *Terminology*

- A. The words and terms discussed in the following paragraphs are not defined but, when used in the Bidding Requirements or Contract Documents, have the indicated meaning.
- B. *Intent of Certain Terms or Adjectives:*
1. The Contract Documents include the terms “as allowed,” “as approved,” “as ordered,” “as directed” or terms of like effect or import to authorize an exercise of professional judgment by Engineer. In addition, the adjectives “reasonable,” “suitable,” “acceptable,” “proper,” “satisfactory,” or adjectives of like effect or import are used to describe an action or determination of Engineer as to the Work. It is intended that such exercise of professional judgment, action, or determination will be solely to evaluate, in general, the Work for compliance with the information in the Contract Documents and with the design concept of the Project as a functioning whole as shown or indicated in the Contract Documents (unless there is a specific statement indicating otherwise). The use of any such term or adjective is not intended to and shall not be effective to assign to Engineer any duty or authority to supervise or direct the performance of the Work, or any duty or authority to undertake responsibility contrary to the provisions of Article 10 or any other provision of the Contract Documents.
- C. *Day:*
1. The word “day” means a calendar day of 24 hours measured from midnight to the next midnight.
- D. *Defective:*
1. The word “defective,” when modifying the word “Work,” refers to Work that is unsatisfactory, faulty, or deficient in that it:
 - a. does not conform to the Contract Documents; or
 - b. does not meet the requirements of any applicable inspection, reference standard, test, or approval referred to in the Contract Documents; or
 - c. has been damaged prior to Engineer’s recommendation of final payment (unless responsibility for the protection thereof has been assumed by Owner at Substantial Completion in accordance with Paragraph 15.03 or 15.04).
- E. *Furnish, Install, Perform, Provide:*
1. The word “furnish,” when used in connection with services, materials, or equipment, shall mean to supply and deliver said services, materials, or equipment to the Site (or some other specified location) ready for use or installation and in usable or operable condition.
 2. The word “install,” when used in connection with services, materials, or equipment, shall mean to put into use or place in final position said services, materials, or equipment complete and ready for intended use.

3. The words "perform" or "provide," when used in connection with services, materials, or equipment, shall mean to furnish and install said services, materials, or equipment complete and ready for intended use.
 4. If the Contract Documents establish an obligation of Contractor with respect to specific services, materials, or equipment, but do not expressly use any of the four words "furnish," "install," "perform," or "provide," then Contractor shall furnish and install said services, materials, or equipment complete and ready for intended use.
- F. Unless stated otherwise in the Contract Documents, words or phrases that have a well-known technical or construction industry or trade meaning are used in the Contract Documents in accordance with such recognized meaning.

ARTICLE 2 – PRELIMINARY MATTERS

2.01 *Delivery of Bonds and Evidence of Insurance*

- A. *Bonds:* When Contractor delivers the executed counterparts of the Agreement to Owner, Contractor shall also deliver to Owner such bonds as Contractor may be required to furnish.
- B. *Evidence of Contractor's Insurance:* When Contractor delivers the executed counterparts of the Agreement to Owner, Contractor shall also deliver to Owner, with copies to each named insured and additional insured (as identified in the Supplementary Conditions or elsewhere in the Contract), the certificates and other evidence of insurance required to be provided by Contractor in accordance with Article 6.
- C. *Evidence of Owner's Insurance:* After receipt of the executed counterparts of the Agreement and all required bonds and insurance documentation, Owner shall promptly deliver to Contractor, with copies to each named insured and additional insured (as identified in the Supplementary Conditions or otherwise), the certificates and other evidence of insurance required to be provided by Owner under Article 6.

2.02 *Copies of Documents*

- A. Owner shall furnish to Contractor four printed copies of the Contract (including one fully executed counterpart of the Agreement), and one copy in electronic portable document format (PDF). Additional printed copies will be furnished upon request at the cost of reproduction.
- B. Owner shall maintain and safeguard at least one original printed record version of the Contract, including Drawings and Specifications signed and sealed by Engineer and other design professionals. Owner shall make such original printed record version of the Contract available to Contractor for review. Owner may delegate the responsibilities under this provision to Engineer.

2.03 *Before Starting Construction*

- A. *Preliminary Schedules:* Within 10 days after the Effective Date of the Contract (or as otherwise specifically required by the Contract Documents), Contractor shall submit to Engineer for timely review:
 1. a preliminary Progress Schedule indicating the times (numbers of days or dates) for starting and completing the various stages of the Work, including any Milestones specified in the Contract;
 2. a preliminary Schedule of Submittals; and

3. a preliminary Schedule of Values for all of the Work which includes quantities and prices of items which when added together equal the Contract Price and subdivides the Work into component parts in sufficient detail to serve as the basis for progress payments during performance of the Work. Such prices will include an appropriate amount of overhead and profit applicable to each item of Work.

2.04 *Preconstruction Conference; Designation of Authorized Representatives*

- A. Before any Work at the Site is started, a conference attended by Owner, Contractor, Engineer, and others as appropriate will be held to establish a working understanding among the parties as to the Work and to discuss the schedules referred to in Paragraph 2.03.A, procedures for handling Shop Drawings, Samples, and other submittals, processing Applications for Payment, electronic or digital transmittals, and maintaining required records.
- B. At this conference Owner and Contractor each shall designate, in writing, a specific individual to act as its authorized representative with respect to the services and responsibilities under the Contract. Such individuals shall have the authority to transmit and receive information, render decisions relative to the Contract, and otherwise act on behalf of each respective party.

2.05 *Initial Acceptance of Schedules*

- A. At least 10 days before submission of the first Application for Payment a conference, attended by Contractor, Engineer, and others as appropriate, will be held to review for acceptability to Engineer as provided below the schedules submitted in accordance with Paragraph 2.03.A. Contractor shall have an additional 10 days to make corrections and adjustments and to complete and resubmit the schedules. No progress payment shall be made to Contractor until acceptable schedules are submitted to Engineer.
 1. The Progress Schedule will be acceptable to Engineer if it provides an orderly progression of the Work to completion within the Contract Times. Such acceptance will not impose on Engineer responsibility for the Progress Schedule, for sequencing, scheduling, or progress of the Work, nor interfere with or relieve Contractor from Contractor's full responsibility therefor.
 2. Contractor's Schedule of Submittals will be acceptable to Engineer if it provides a workable arrangement for reviewing and processing the required submittals.
 3. Contractor's Schedule of Values will be acceptable to Engineer as to form and substance if it provides a reasonable allocation of the Contract Price to the component parts of the Work.

2.06 *Electronic Transmittals*

- A. Except as otherwise stated elsewhere in the Contract, the Owner, Engineer, and Contractor may transmit, and shall accept, Project-related correspondence, text, data, documents, drawings, information, and graphics, including but not limited to Shop Drawings and other submittals, in electronic media or digital format, either directly, or through access to a secure Project website.
- B. If the Contract does not establish protocols for electronic or digital transmittals, then Owner, Engineer, and Contractor shall jointly develop such protocols.
- C. When transmitting items in electronic media or digital format, the transmitting party makes no representations as to long term compatibility, usability, or readability of the items resulting from the recipient's use of software application packages, operating systems, or

computer hardware differing from those used in the drafting or transmittal of the items, or from those established in applicable transmittal protocols.

ARTICLE 3 – DOCUMENTS: INTENT, REQUIREMENTS, REUSE

3.01 *Intent*

- A. The Contract Documents are complementary; what is required by one is as binding as if required by all.
- B. It is the intent of the Contract Documents to describe a functionally complete project (or part thereof) to be constructed in accordance with the Contract Documents.
- C. Unless otherwise stated in the Contract Documents, if there is a discrepancy between the electronic or digital versions of the Contract Documents (including any printed copies derived from such electronic or digital versions) and the printed record version, the printed record version shall govern.
- D. The Contract supersedes prior negotiations, representations, and agreements, whether written or oral.
- E. Engineer will issue clarifications and interpretations of the Contract Documents as provided herein.

3.02 *Reference Standards*

- A. Standards Specifications, Codes, Laws and Regulations
 1. Reference in the Contract Documents to standard specifications, manuals, reference standards, or codes of any technical society, organization, or association, or to Laws or Regulations, whether such reference be specific or by implication, shall mean the standard specification, manual, reference standard, code, or Laws or Regulations in effect at the time of opening of Bids (or on the Effective Date of the Contract if there were no Bids), except as may be otherwise specifically stated in the Contract Documents.
 2. No provision of any such standard specification, manual, reference standard, or code, or any instruction of a Supplier, shall be effective to change the duties or responsibilities of Owner, Contractor, or Engineer, or any of their subcontractors, consultants, agents, or employees, from those set forth in the part of the Contract Documents prepared by or for Engineer. No such provision or instruction shall be effective to assign to Owner, Engineer, or any of their officers, directors, members, partners, employees, agents, consultants, or subcontractors, any duty or authority to supervise or direct the performance of the Work or any duty or authority to undertake responsibility inconsistent with the provisions of the part of the Contract Documents prepared by or for Engineer.

3.03 *Reporting and Resolving Discrepancies*

A. *Reporting Discrepancies:*

1. *Contractor's Verification of Figures and Field Measurements:* Before undertaking each part of the Work, Contractor shall carefully study the Contract Documents, and check and verify pertinent figures and dimensions therein, particularly with respect to applicable field measurements. Contractor shall promptly report in writing to Engineer any conflict, error, ambiguity, or discrepancy that Contractor discovers, or has actual knowledge of, and shall not proceed with any Work affected thereby until the conflict,

error, ambiguity, or discrepancy is resolved, by a clarification or interpretation by Engineer, or by an amendment or supplement to the Contract Documents issued pursuant to Paragraph 11.01.

2. *Contractor's Review of Contract Documents:* If, before or during the performance of the Work, Contractor discovers any conflict, error, ambiguity, or discrepancy within the Contract Documents, or between the Contract Documents and (a) any applicable Law or Regulation, (b) actual field conditions, (c) any standard specification, manual, reference standard, or code, or (d) any instruction of any Supplier, then Contractor shall promptly report it to Engineer in writing. Contractor shall not proceed with the Work affected thereby (except in an emergency as required by Paragraph 7.15) until the conflict, error, ambiguity, or discrepancy is resolved, by a clarification or interpretation by Engineer, or by an amendment or supplement to the Contract Documents issued pursuant to Paragraph 11.01.
3. Contractor shall not be liable to Owner or Engineer for failure to report any conflict, error, ambiguity, or discrepancy in the Contract Documents unless Contractor had actual knowledge thereof.

B. *Resolving Discrepancies:*

1. Except as may be otherwise specifically stated in the Contract Documents, the provisions of the part of the Contract Documents prepared by or for Engineer shall take precedence in resolving any conflict, error, ambiguity, or discrepancy between such provisions of the Contract Documents and:
 - a. the provisions of any standard specification, manual, reference standard, or code, or the instruction of any Supplier (whether or not specifically incorporated by reference as a Contract Document); or
 - b. the provisions of any Laws or Regulations applicable to the performance of the Work (unless such an interpretation of the provisions of the Contract Documents would result in violation of such Law or Regulation).

3.04 *Requirements of the Contract Documents*

- A. During the performance of the Work and until final payment, Contractor and Owner shall submit to the Engineer all matters in question concerning the requirements of the Contract Documents (sometimes referred to as requests for information or interpretation—RFIs), or relating to the acceptability of the Work under the Contract Documents, as soon as possible after such matters arise. Engineer will be the initial interpreter of the requirements of the Contract Documents, and judge of the acceptability of the Work thereunder.
- B. Engineer will, with reasonable promptness, render a written clarification, interpretation, or decision on the issue submitted, or initiate an amendment or supplement to the Contract Documents. Engineer's written clarification, interpretation, or decision will be final and binding on Contractor, unless it appeals by submitting a Change Proposal, and on Owner, unless it appeals by filing a Claim.
- C. If a submitted matter in question concerns terms and conditions of the Contract Documents that do not involve (1) the performance or acceptability of the Work under the Contract Documents, (2) the design (as set forth in the Drawings, Specifications, or otherwise), or (3) other engineering or technical matters, then Engineer will promptly give written notice to Owner and Contractor that Engineer is unable to provide a decision or interpretation. If Owner and Contractor are unable to agree on resolution of such a matter in question, either party may pursue resolution as provided in Article 12.

3.05 *Reuse of Documents*

- A. Contractor and its Subcontractors and Suppliers shall not:
1. have or acquire any title to or ownership rights in any of the Drawings, Specifications, or other documents (or copies of any thereof) prepared by or bearing the seal of Engineer or its consultants, including electronic media editions, or reuse any such Drawings, Specifications, other documents, or copies thereof on extensions of the Project or any other project without written consent of Owner and Engineer and specific written verification or adaptation by Engineer; or
 2. have or acquire any title or ownership rights in any other Contract Documents, reuse any such Contract Documents for any purpose without Owner's express written consent, or violate any copyrights pertaining to such Contract Documents.
- B. The prohibitions of this Paragraph 3.05 will survive final payment, or termination of the Contract. Nothing herein shall preclude Contractor from retaining copies of the Contract Documents for record purposes.

ARTICLE 4 – COMMENCEMENT AND PROGRESS OF THE WORK

4.01 *Commencement of Contract Times; Notice to Proceed*

- A. The Contract Times will commence to run on the thirtieth day after the Effective Date of the Contract or, if a Notice to Proceed is given, on the day indicated in the Notice to Proceed. A Notice to Proceed may be given at any time within 30 days after the Effective Date of the Contract. In no event will the Contract Times commence to run later than the sixtieth day after the day of Bid opening or the thirtieth day after the Effective Date of the Contract, whichever date is earlier.

4.02 *Starting the Work*

- A. Contractor shall start to perform the Work on the date when the Contract Times commence to run. No Work shall be done at the Site prior to such date.

4.03 *Reference Points*

- A. Owner shall provide engineering surveys to establish reference points for construction which in Engineer's judgment are necessary to enable Contractor to proceed with the Work. Contractor shall be responsible for laying out the Work, shall protect and preserve the established reference points and property monuments, and shall make no changes or relocations without the prior written approval of Owner. Contractor shall report to Engineer whenever any reference point or property monument is lost or destroyed or requires relocation because of necessary changes in grades or locations, and shall be responsible for the accurate replacement or relocation of such reference points or property monuments by professionally qualified personnel.

4.04 *Progress Schedule*

- A. Contractor shall adhere to the Progress Schedule established in accordance with Paragraph 2.05 as it may be adjusted from time to time as provided below.
1. Contractor shall submit to Engineer for acceptance (to the extent indicated in Paragraph 2.05) proposed adjustments in the Progress Schedule that will not result in changing the Contract Times.

2. Proposed adjustments in the Progress Schedule that will change the Contract Times shall be submitted in accordance with the requirements of Article 11.

B. Contractor shall carry on the Work and adhere to the Progress Schedule during all disputes or disagreements with Owner. No Work shall be delayed or postponed pending resolution of any disputes or disagreements, or during any appeal process, except as permitted by Paragraph 16.04, or as Owner and Contractor may otherwise agree in writing.

4.05 *Delays in Contractor's Progress*

A. If Owner, Engineer, or anyone for whom Owner is responsible, delays, disrupts, or interferes with the performance or progress of the Work, then Contractor shall be entitled to an equitable adjustment in the Contract Times and Contract Price. Contractor's entitlement to an adjustment of the Contract Times is conditioned on such adjustment being essential to Contractor's ability to complete the Work within the Contract Times.

B. Contractor shall not be entitled to an adjustment in Contract Price or Contract Times for delay, disruption, or interference caused by or within the control of Contractor. Delay, disruption, and interference attributable to and within the control of a Subcontractor or Supplier shall be deemed to be within the control of Contractor.

C. If Contractor's performance or progress is delayed, disrupted, or interfered with by unanticipated causes not the fault of and beyond the control of Owner, Contractor, and those for which they are responsible, then Contractor shall be entitled to an equitable adjustment in Contract Times. Contractor's entitlement to an adjustment of the Contract Times is conditioned on such adjustment being essential to Contractor's ability to complete the Work within the Contract Times. Such an adjustment shall be Contractor's sole and exclusive remedy for the delays, disruption, and interference described in this paragraph. Causes of delay, disruption, or interference that may give rise to an adjustment in Contract Times under this paragraph include but are not limited to the following:

1. severe and unavoidable natural catastrophes such as fires, floods, epidemics, and earthquakes;
2. abnormal weather conditions;
3. acts or failures to act of utility owners (other than those performing other work at or adjacent to the Site by arrangement with the Owner, as contemplated in Article 8); and
4. acts of war or terrorism.

D. Delays, disruption, and interference to the performance or progress of the Work resulting from the existence of a differing subsurface or physical condition, an Underground Facility that was not shown or indicated by the Contract Documents, or not shown or indicated with reasonable accuracy, and those resulting from Hazardous Environmental Conditions, are governed by Article 5.

E. Paragraph 8.03 governs delays, disruption, and interference to the performance or progress of the Work resulting from the performance of certain other work at or adjacent to the Site.

F. Contractor shall not be entitled to an adjustment in Contract Price or Contract Times for any delay, disruption, or interference if such delay is concurrent with a delay, disruption, or interference caused by or within the control of Contractor.

- G. Contractor must submit any Change Proposal seeking an adjustment in Contract Price or Contract Times under this paragraph within 30 days of the commencement of the delaying, disrupting, or interfering event.

ARTICLE 5 – AVAILABILITY OF LANDS; SUBSURFACE AND PHYSICAL CONDITIONS; HAZARDOUS ENVIRONMENTAL CONDITIONS

5.01 Availability of Lands

- A. Owner shall furnish the Site. Owner shall notify Contractor of any encumbrances or restrictions not of general application but specifically related to use of the Site with which Contractor must comply in performing the Work.
- B. Upon reasonable written request, Owner shall furnish Contractor with a current statement of record legal title and legal description of the lands upon which permanent improvements are to be made and Owner's interest therein as necessary for giving notice of or filing a mechanic's or construction lien against such lands in accordance with applicable Laws and Regulations.
- C. Contractor shall provide for all additional lands and access thereto that may be required for temporary construction facilities or storage of materials and equipment.

5.02 Use of Site and Other Areas

A. Limitation on Use of Site and Other Areas:

- 1. Contractor shall confine construction equipment, temporary construction facilities, the storage of materials and equipment, and the operations of workers to the Site, adjacent areas that Contractor has arranged to use through construction easements or otherwise, and other adjacent areas permitted by Laws and Regulations, and shall not unreasonably encumber the Site and such other adjacent areas with construction equipment or other materials or equipment. Contractor shall assume full responsibility for (a) damage to the Site; (b) damage to any such other adjacent areas used for Contractor's operations; (c) damage to any other adjacent land or areas; and (d) for injuries and losses sustained by the owners or occupants of any such land or areas; provided that such damage or injuries result from the performance of the Work or from other actions or conduct of the Contractor or those for which Contractor is responsible.
- 2. If a damage or injury claim is made by the owner or occupant of any such land or area because of the performance of the Work, or because of other actions or conduct of the Contractor or those for which Contractor is responsible, Contractor shall (a) take immediate corrective or remedial action as required by Paragraph 7.12, or otherwise; (b) promptly attempt to settle the claim as to all parties through negotiations with such owner or occupant, or otherwise resolve the claim by arbitration or other dispute resolution proceeding, or at law; and (c) to the fullest extent permitted by Laws and Regulations, indemnify and hold harmless Owner and Engineer, and the officers, directors, members, partners, employees, agents, consultants and subcontractors of each and any of them from and against any such claim, and against all costs, losses, and damages (including but not limited to all fees and charges of engineers, architects, attorneys, and other professionals and all court or arbitration or other dispute resolution costs) arising out of or relating to any claim or action, legal or equitable, brought by any such owner or occupant against Owner, Engineer, or any other party indemnified hereunder to the extent caused directly or indirectly, in whole or in part

by, or based upon, Contractor's performance of the Work, or because of other actions or conduct of the Contractor or those for which Contractor is responsible.

- B. *Removal of Debris During Performance of the Work:* During the progress of the Work the Contractor shall keep the Site and other adjacent areas free from accumulations of waste materials, rubbish, and other debris. Removal and disposal of such waste materials, rubbish, and other debris shall conform to applicable Laws and Regulations.
- C. *Cleaning:* Prior to Substantial Completion of the Work Contractor shall clean the Site and the Work and make it ready for utilization by Owner. At the completion of the Work Contractor shall remove from the Site and adjacent areas all tools, appliances, construction equipment and machinery, and surplus materials and shall restore to original condition all property not designated for alteration by the Contract Documents.
- D. *Loading of Structures:* Contractor shall not load nor permit any part of any structure to be loaded in any manner that will endanger the structure, nor shall Contractor subject any part of the Work or adjacent structures or land to stresses or pressures that will endanger them.

5.03 *Subsurface and Physical Conditions*

- A. *Reports and Drawings:* The Supplementary Conditions Identify:
 - 1. those reports known to Owner of explorations and tests of subsurface conditions at or adjacent to the Site;
 - 2. those drawings known to Owner of physical conditions relating to existing surface or subsurface structures at the Site (except Underground Facilities); and
 - 3. Technical Data contained in such reports and drawings.
- B. *Reliance by Contractor on Technical Data Authorized:* Contractor may rely upon the accuracy of the Technical Data expressly identified in the Supplementary Conditions with respect to such reports and drawings, but such reports and drawings are not Contract Documents. If no such express identification has been made, then Contractor may rely upon the accuracy of the Technical Data (as defined in Article 1) contained in any geotechnical or environmental report prepared for the Project and made available to Contractor. Except for such reliance on Technical Data, Contractor may not rely upon or make any claim against Owner or Engineer, or any of their officers, directors, members, partners, employees, agents, consultants, or subcontractors, with respect to:
 - 1. the completeness of such reports and drawings for Contractor's purposes, including, but not limited to, any aspects of the means, methods, techniques, sequences, and procedures of construction to be employed by Contractor, and safety precautions and programs incident thereto; or
 - 2. other data, interpretations, opinions, and information contained in such reports or shown or indicated in such drawings; or
 - 3. any Contractor interpretation of or conclusion drawn from any Technical Data or any such other data, interpretations, opinions, or information.

5.04 *Differing Subsurface or Physical Conditions*

A. *Notice by Contractor:* If Contractor believes that any subsurface or physical condition that is uncovered or revealed at the Site either:

1. is of such a nature as to establish that any Technical Data on which Contractor is entitled to rely as provided in Paragraph 5.03 is materially inaccurate; or
2. is of such a nature as to require a change in the Drawings or Specifications; or
3. differs materially from that shown or indicated in the Contract Documents; or
4. is of an unusual nature, and differs materially from conditions ordinarily encountered and generally recognized as inherent in work of the character provided for in the Contract Documents;

then Contractor shall, promptly after becoming aware thereof and before further disturbing the subsurface or physical conditions or performing any Work in connection therewith (except in an emergency as required by Paragraph 7.15), notify Owner and Engineer in writing about such condition. Contractor shall not further disturb such condition or perform any Work in connection therewith (except with respect to an emergency) until receipt of a written statement permitting Contractor to do so.

B. *Engineer's Review:* After receipt of written notice as required by the preceding paragraph, Engineer will promptly review the subsurface or physical condition in question; determine the necessity of Owner's obtaining additional exploration or tests with respect to the condition; conclude whether the condition falls within any one or more of the differing site condition categories in Paragraph 5.04.A above; obtain any pertinent cost or schedule information from Contractor; prepare recommendations to Owner regarding the Contractor's resumption of Work in connection with the subsurface or physical condition in question and the need for any change in the Drawings or Specifications; and advise Owner in writing of Engineer's findings, conclusions, and recommendations.

C. *Owner's Statement to Contractor Regarding Site Condition:* After receipt of Engineer's written findings, conclusions, and recommendations, Owner shall issue a written statement to Contractor (with a copy to Engineer) regarding the subsurface or physical condition in question, addressing the resumption of Work in connection with such condition, indicating whether any change in the Drawings or Specifications will be made, and adopting or rejecting Engineer's written findings, conclusions, and recommendations, in whole or in part.

D. *Possible Price and Times Adjustments:*

1. Contractor shall be entitled to an equitable adjustment in Contract Price or Contract Times, or both, to the extent that the existence of a differing subsurface or physical condition, or any related delay, disruption, or interference, causes an increase or decrease in Contractor's cost of, or time required for, performance of the Work; subject, however, to the following:
 - a. such condition must fall within any one or more of the categories described in Paragraph 5.04.A;
 - b. with respect to Work that is paid for on a unit price basis, any adjustment in Contract Price will be subject to the provisions of Paragraph 13.03; and,

- c. Contractor's entitlement to an adjustment of the Contract Times is conditioned on such adjustment being essential to Contractor's ability to complete the Work within the Contract Times.
2. Contractor shall not be entitled to any adjustment in the Contract Price or Contract Times with respect to a subsurface or physical condition if:
 - a. Contractor knew of the existence of such condition at the time Contractor made a commitment to Owner with respect to Contract Price and Contract Times by the submission of a Bid or becoming bound under a negotiated contract, or otherwise; or
 - b. the existence of such condition reasonably could have been discovered or revealed as a result of any examination, investigation, exploration, test, or study of the Site and contiguous areas expressly required by the Bidding Requirements or Contract Documents to be conducted by or for Contractor prior to Contractor's making such commitment; or
 - c. Contractor failed to give the written notice as required by Paragraph 5.04.A.
3. If Owner and Contractor agree regarding Contractor's entitlement to and the amount or extent of any adjustment in the Contract Price or Contract Times, or both, then any such adjustment shall be set forth in a Change Order.
4. Contractor may submit a Change Proposal regarding its entitlement to or the amount or extent of any adjustment in the Contract Price or Contract Times, or both, no later than 30 days after Owner's issuance of the Owner's written statement to Contractor regarding the subsurface or physical condition in question.

5.05 *Underground Facilities*

- A. *Contractor's Responsibilities:* The information and data shown or indicated in the Contract Documents with respect to existing Underground Facilities at or adjacent to the Site is based on information and data furnished to Owner or Engineer by the owners of such Underground Facilities, including Owner, or by others. Unless it is otherwise expressly provided in the Supplementary Conditions:
 1. Owner and Engineer do not warrant or guarantee the accuracy or completeness of any such information or data provided by others; and
 2. the cost of all of the following will be included in the Contract Price, and Contractor shall have full responsibility for:
 - a. reviewing and checking all information and data regarding existing Underground Facilities at the Site;
 - b. locating all Underground Facilities shown or indicated in the Contract Documents as being at the Site;
 - c. coordination of the Work with the owners (including Owner) of such Underground Facilities, during construction; and
 - d. the safety and protection of all existing Underground Facilities at the Site, and repairing any damage thereto resulting from the Work.
- B. *Notice by Contractor:* If Contractor believes that an Underground Facility that is uncovered or revealed at the Site was not shown or indicated in the Contract Documents, or was not shown or indicated with reasonable accuracy, then Contractor shall, promptly after

becoming aware thereof and before further disturbing conditions affected thereby or performing any Work in connection therewith (except in an emergency as required by Paragraph 7.15), identify the owner of such Underground Facility and give written notice to that owner and to Owner and Engineer.

- C. *Engineer's Review:* Engineer will promptly review the Underground Facility and conclude whether such Underground Facility was not shown or indicated in the Contract Documents, or was not shown or indicated with reasonable accuracy; obtain any pertinent cost or schedule information from Contractor; prepare recommendations to Owner regarding the Contractor's resumption of Work in connection with the Underground Facility in question; determine the extent, if any, to which a change is required in the Drawings or Specifications to reflect and document the consequences of the existence or location of the Underground Facility; and advise Owner in writing of Engineer's findings, conclusions, and recommendations. During such time, Contractor shall be responsible for the safety and protection of such Underground Facility.
- D. *Owner's Statement to Contractor Regarding Underground Facility:* After receipt of Engineer's written findings, conclusions, and recommendations, Owner shall issue a written statement to Contractor (with a copy to Engineer) regarding the Underground Facility in question, addressing the resumption of Work in connection with such Underground Facility, indicating whether any change in the Drawings or Specifications will be made, and adopting or rejecting Engineer's written findings, conclusions, and recommendations in whole or in part.
- E. *Possible Price and Times Adjustments:*
 - 1. Contractor shall be entitled to an equitable adjustment in the Contract Price or Contract Times, or both, to the extent that any existing Underground Facility at the Site that was not shown or indicated in the Contract Documents, or was not shown or indicated with reasonable accuracy, or any related delay, disruption, or interference, causes an increase or decrease in Contractor's cost of, or time required for, performance of the Work; subject, however, to the following:
 - a. Contractor did not know of and could not reasonably have been expected to be aware of or to have anticipated the existence or actual location of the Underground Facility in question;
 - b. With respect to Work that is paid for on a unit price basis, any adjustment in Contract Price will be subject to the provisions of Paragraph 13.03;
 - c. Contractor's entitlement to an adjustment of the Contract Times is conditioned on such adjustment being essential to Contractor's ability to complete the Work within the Contract Times; and
 - d. Contractor gave the notice required in Paragraph 5.05.B.
 - 2. If Owner and Contractor agree regarding Contractor's entitlement to and the amount or extent of any adjustment in the Contract Price or Contract Times, or both, then any such adjustment shall be set forth in a Change Order.
 - 3. Contractor may submit a Change Proposal regarding its entitlement to or the amount or extent of any adjustment in the Contract Price or Contract Times, or both, no later than 30 days after Owner's issuance of the Owner's written statement to Contractor regarding the Underground Facility in question.

5.06 *Hazardous Environmental Conditions at Site*

- A. *Reports and Drawings:* The Supplementary Conditions identify:
1. those reports and drawings known to Owner relating to Hazardous Environmental Conditions that have been identified at or adjacent to the Site; and
 2. Technical Data contained in such reports and drawings.
- B. *Reliance by Contractor on Technical Data Authorized:* Contractor may rely upon the accuracy of the Technical Data expressly identified in the Supplementary Conditions with respect to such reports and drawings, but such reports and drawings are not Contract Documents. If no such express identification has been made, then Contractor may rely on the accuracy of the Technical Data (as defined in Article 1) contained in any geotechnical or environmental report prepared for the Project and made available to Contractor. Except for such reliance on Technical Data, Contractor may not rely upon or make any claim against Owner or Engineer, or any of their officers, directors, members, partners, employees, agents, consultants, or subcontractors with respect to:
1. the completeness of such reports and drawings for Contractor's purposes, including, but not limited to, any aspects of the means, methods, techniques, sequences and procedures of construction to be employed by Contractor and safety precautions and programs incident thereto; or
 2. other data, interpretations, opinions and information contained in such reports or shown or indicated in such drawings; or
 3. any Contractor interpretation of or conclusion drawn from any Technical Data or any such other data, interpretations, opinions or information.
- C. Contractor shall not be responsible for removing or remediating any Hazardous Environmental Condition encountered, uncovered, or revealed at the Site unless such removal or remediation is expressly identified in the Contract Documents to be within the scope of the Work.
- D. Contractor shall be responsible for controlling, containing, and duly removing all Constituents of Concern brought to the Site by Contractor, Subcontractors, Suppliers, or anyone else for whom Contractor is responsible, and for any associated costs; and for the costs of removing and remediating any Hazardous Environmental Condition created by the presence of any such Constituents of Concern.
- E. If Contractor encounters, uncovers, or reveals a Hazardous Environmental Condition whose removal or remediation is not expressly identified in the Contract Documents as being within the scope of the Work, or if Contractor or anyone for whom Contractor is responsible creates a Hazardous Environmental Condition, then Contractor shall immediately: (1) secure or otherwise isolate such condition; (2) stop all Work in connection with such condition and in any area affected thereby (except in an emergency as required by Paragraph 7.15); and (3) notify Owner and Engineer (and promptly thereafter confirm such notice in writing). Owner shall promptly consult with Engineer concerning the necessity for Owner to retain a qualified expert to evaluate such condition or take corrective action, if any. Promptly after consulting with Engineer, Owner shall take such actions as are necessary to permit Owner to timely obtain required permits and provide Contractor the written notice required by Paragraph 5.06.F. If Contractor or anyone for whom Contractor is responsible created the Hazardous Environmental Condition in question, then Owner may remove and remediate the Hazardous Environmental Condition, and impose a set-off against payments to account for the associated costs.

- F. Contractor shall not resume Work in connection with such Hazardous Environmental Condition or in any affected area until after Owner has obtained any required permits related thereto, and delivered written notice to Contractor either (1) specifying that such condition and any affected area is or has been rendered safe for the resumption of Work, or (2) specifying any special conditions under which such Work may be resumed safely.
- G. If Owner and Contractor cannot agree as to entitlement to or on the amount or extent, if any, of any adjustment in Contract Price or Contract Times, or both, as a result of such Work stoppage or such special conditions under which Work is agreed to be resumed by Contractor, then within 30 days of Owner's written notice regarding the resumption of Work, Contractor may submit a Change Proposal, or Owner may impose a set-off.
- H. If after receipt of such written notice Contractor does not agree to resume such Work based on a reasonable belief it is unsafe, or does not agree to resume such Work under such special conditions, then Owner may order the portion of the Work that is in the area affected by such condition to be deleted from the Work, following the contractual change procedures in Article 11. Owner may have such deleted portion of the Work performed by Owner's own forces or others in accordance with Article 8.
- I. To the fullest extent permitted by Laws and Regulations, Owner shall indemnify and hold harmless Contractor, Subcontractors, and Engineer, and the officers, directors, members, partners, employees, agents, consultants, and subcontractors of each and any of them from and against all claims, costs, losses, and damages (including but not limited to all fees and charges of engineers, architects, attorneys, and other professionals and all court or arbitration or other dispute resolution costs) arising out of or relating to a Hazardous Environmental Condition, provided that such Hazardous Environmental Condition (1) was not shown or indicated in the Drawings, Specifications, or other Contract Documents, identified as Technical Data entitled to limited reliance pursuant to Paragraph 5.06.B, or identified in the Contract Documents to be included within the scope of the Work, and (2) was not created by Contractor or by anyone for whom Contractor is responsible. Nothing in this Paragraph 5.06.I shall obligate Owner to indemnify any individual or entity from and against the consequences of that individual's or entity's own negligence.
- J. To the fullest extent permitted by Laws and Regulations, Contractor shall indemnify and hold harmless Owner and Engineer, and the officers, directors, members, partners, employees, agents, consultants, and subcontractors of each and any of them from and against all claims, costs, losses, and damages (including but not limited to all fees and charges of engineers, architects, attorneys, and other professionals and all court or arbitration or other dispute resolution costs) arising out of or relating to the failure to control, contain, or remove a Constituent of Concern brought to the Site by Contractor or by anyone for whom Contractor is responsible, or to a Hazardous Environmental Condition created by Contractor or by anyone for whom Contractor is responsible. Nothing in this Paragraph 5.06.J shall obligate Contractor to indemnify any individual or entity from and against the consequences of that individual's or entity's own negligence.
- K. The provisions of Paragraphs 5.03, 5.04, and 5.05 do not apply to the presence of Constituents of Concern or to a Hazardous Environmental Condition uncovered or revealed at the Site.

ARTICLE 6 – BONDS AND INSURANCE

6.01 *Performance, Payment, and Other Bonds*

- A. Contractor shall furnish a performance bond and a payment bond, each in an amount at least equal to the Contract Price, as security for the faithful performance and payment of all of Contractor's obligations under the Contract. These bonds shall remain in effect until one year after the date when final payment becomes due or until completion of the correction period specified in Paragraph 15.08; whichever is later, except as provided otherwise by Laws or Regulations, the Supplementary Conditions, or other specific provisions of the Contract. Contractor shall also furnish such other bonds as are required by the Supplementary Conditions or other specific provisions of the Contract.
- B. All bonds shall be in the form prescribed by the Contract except as provided otherwise by Laws or Regulations, and shall be executed by such sureties as are named in "Companies Holding Certificates of Authority as Acceptable Sureties on Federal Bonds and as Acceptable Reinsuring Companies" as published in Circular 570 (as amended and supplemented) by the Financial Management Service, Surety Bond Branch, U.S. Department of the Treasury. A bond signed by an agent or attorney-in-fact must be accompanied by a certified copy of that individual's authority to bind the surety. The evidence of authority shall show that it is effective on the date the agent or attorney-in-fact signed the accompanying bond.
- C. Contractor shall obtain the required bonds from surety companies that are duly licensed or authorized in the jurisdiction in which the Project is located to issue bonds in the required amounts.
- D. If the surety on a bond furnished by Contractor is declared bankrupt or becomes insolvent, or its right to do business is terminated in any state or jurisdiction where any part of the Project is located, or the surety ceases to meet the requirements above, then Contractor shall promptly notify Owner and Engineer and shall, within 20 days after the event giving rise to such notification, provide another bond and surety, both of which shall comply with the bond and surety requirements above.
- E. If Contractor has failed to obtain a required bond, Owner may exclude the Contractor from the Site and exercise Owner's termination rights under Article 16.
- F. Upon request, Owner shall provide a copy of the payment bond to any Subcontractor, Supplier, or other person or entity claiming to have furnished labor or materials used in the performance of the Work.

6.02 *Insurance—General Provisions*

- A. Owner and Contractor shall obtain and maintain insurance as required in this Article and in the Supplementary Conditions.
- B. All insurance required by the Contract to be purchased and maintained by Owner or Contractor shall be obtained from insurance companies that are duly licensed or authorized, in the state or jurisdiction in which the Project is located, to issue insurance policies for the required limits and coverages. Unless a different standard is indicated in the Supplementary Conditions, all companies that provide insurance policies required under this Contract shall have an A.M. Best rating of A-VII or better.
- C. Contractor shall deliver to Owner, with copies to each named insured and additional insured (as identified in this Article, in the Supplementary Conditions, or elsewhere in the Contract), certificates of insurance establishing that Contractor has obtained and is

maintaining the policies, coverages, and endorsements required by the Contract. Upon request by Owner or any other insured, Contractor shall also furnish other evidence of such required insurance, including but not limited to copies of policies and endorsements, and documentation of applicable self-insured retentions and deductibles. Contractor may block out (redact) any confidential premium or pricing information contained in any policy or endorsement furnished under this provision.

- D. Owner shall deliver to Contractor, with copies to each named insured and additional insured (as identified in this Article, the Supplementary Conditions, or elsewhere in the Contract), certificates of insurance establishing that Owner has obtained and is maintaining the policies, coverages, and endorsements required of Owner by the Contract (if any). Upon request by Contractor or any other insured, Owner shall also provide other evidence of such required insurance (if any), including but not limited to copies of policies and endorsements, and documentation of applicable self-insured retentions and deductibles. Owner may block out (redact) any confidential premium or pricing information contained in any policy or endorsement furnished under this provision.
- E. Failure of Owner or Contractor to demand such certificates or other evidence of the other party's full compliance with these insurance requirements, or failure of Owner or Contractor to identify a deficiency in compliance from the evidence provided, shall not be construed as a waiver of the other party's obligation to obtain and maintain such insurance.
- F. If either party does not purchase or maintain all of the insurance required of such party by the Contract, such party shall notify the other party in writing of such failure to purchase prior to the start of the Work, or of such failure to maintain prior to any change in the required coverage.
- G. If Contractor has failed to obtain and maintain required insurance, Owner may exclude the Contractor from the Site, impose an appropriate set-off against payment, and exercise Owner's termination rights under Article 16.
- H. Without prejudice to any other right or remedy, if a party has failed to obtain required insurance, the other party may elect to obtain equivalent insurance to protect such other party's interests at the expense of the party who was required to provide such coverage, and the Contract Price shall be adjusted accordingly.
- I. Owner does not represent that insurance coverage and limits established in this Contract necessarily will be adequate to protect Contractor or Contractor's interests.
- J. The insurance and insurance limits required herein shall not be deemed as a limitation on Contractor's liability under the indemnities granted to Owner and other individuals and entities in the Contract.

6.03 *Contractor's Insurance*

- A. *Workers' Compensation:* Contractor shall purchase and maintain workers' compensation and employer's liability insurance for:
 - 1. claims under workers' compensation, disability benefits, and other similar employee benefit acts.
 - 2. United States Longshoreman and Harbor Workers' Compensation Act and Jones Act coverage (if applicable).
 - 3. claims for damages because of bodily injury, occupational sickness or disease, or death of Contractor's employees (by stop-gap endorsement in monopolist worker's compensation states).

4. Foreign voluntary worker compensation (if applicable).
- B. *Commercial General Liability—Claims Covered:* Contractor shall purchase and maintain commercial general liability insurance, covering all operations by or on behalf of Contractor, on an occurrence basis, against:
1. claims for damages because of bodily injury, sickness or disease, or death of any person other than Contractor's employees.
 2. claims for damages insured by reasonably available personal injury liability coverage.
 3. claims for damages, other than to the Work itself, because of injury to or destruction of tangible property wherever located, including loss of use resulting therefrom.
- C. *Commercial General Liability—Form and Content:* Contractor's commercial liability policy shall be written on a 1996 (or later) ISO commercial general liability form (occurrence form) and include the following coverages and endorsements:
1. Products and completed operations coverage:
 - a. Such insurance shall be maintained for three years after final payment.
 - b. Contractor shall furnish Owner and each other additional insured (as identified in the Supplementary Conditions or elsewhere in the Contract) evidence of continuation of such insurance at final payment and three years thereafter.
 2. Blanket contractual liability coverage, to the extent permitted by law, including but not limited to coverage of Contractor's contractual indemnity obligations in Paragraph 7.18.
 3. Broad form property damage coverage.
 4. Severability of interest.
 5. Underground, explosion, and collapse coverage.
 6. Personal injury coverage.
 7. Additional insured endorsements that include both ongoing operations and products and completed operations coverage through ISO Endorsements CG 20 10 10 01 and CG 20 37 10 01 (together); or CG 20 10 07 04 and CG 20 37 07 04 (together); or their equivalent.
 8. For design professional additional insureds, ISO Endorsement CG 20 32 07 04, "Additional Insured—Engineers, Architects or Surveyors Not Engaged by the Named Insured" or its equivalent.
- D. *Automobile liability:* Contractor shall purchase and maintain automobile liability insurance against claims for damages because of bodily injury or death of any person or property damage arising out of the ownership, maintenance, or use of any motor vehicle. The automobile liability policy shall be written on an occurrence basis.
- E. *Umbrella or excess liability:* Contractor shall purchase and maintain umbrella or excess liability insurance written over the underlying employer's liability, commercial general liability, and automobile liability insurance described in the paragraphs above. Subject to industry-standard exclusions, the coverage afforded shall follow form as to each and every one of the underlying policies.
- F. *Contractor's pollution liability insurance:* Contractor shall purchase and maintain a policy covering third-party injury and property damage claims, including clean-up costs, as a result

of pollution conditions arising from Contractor's operations and completed operations. This insurance shall be maintained for no less than three years after final completion.

- G. *Additional insureds:* The Contractor's commercial general liability, automobile liability, umbrella or excess, and pollution liability policies shall include and list as additional insureds Owner and Engineer, and any individuals or entities identified in the Supplementary Conditions; include coverage for the respective officers, directors, members, partners, employees, agents, consultants, and subcontractors of each and any of all such additional insureds; and the insurance afforded to these additional insureds shall provide primary coverage for all claims covered thereby (including as applicable those arising from both ongoing and completed operations) on a non-contributory basis. Contractor shall obtain all necessary endorsements to support these requirements.
- H. *Contractor's professional liability insurance:* If Contractor will provide or furnish professional services under this Contract, through a delegation of professional design services or otherwise, then Contractor shall be responsible for purchasing and maintaining applicable professional liability insurance. This insurance shall provide protection against claims arising out of performance of professional design or related services, and caused by a negligent error, omission, or act for which the insured party is legally liable. It shall be maintained throughout the duration of the Contract and for a minimum of two years after Substantial Completion. If such professional design services are performed by a Subcontractor, and not by Contractor itself, then the requirements of this paragraph may be satisfied through the purchasing and maintenance of such insurance by such Subcontractor.
- I. *General provisions:* The policies of insurance required by this Paragraph 6.03 shall:
 - 1. include at least the specific coverages provided in this Article.
 - 2. be written for not less than the limits of liability provided in this Article and in the Supplementary Conditions, or required by Laws or Regulations, whichever is greater.
 - 3. contain a provision or endorsement that the coverage afforded will not be canceled, materially changed, or renewal refused until at least 10 days prior written notice has been given to Contractor. Within three days of receipt of any such written notice, Contractor shall provide a copy of the notice to Owner, Engineer, and each other insured under the policy.
 - 4. remain in effect at least until final payment (and longer if expressly required in this Article) and at all times thereafter when Contractor may be correcting, removing, or replacing defective Work as a warranty or correction obligation, or otherwise, or returning to the Site to conduct other tasks arising from the Contract Documents.
 - 5. be appropriate for the Work being performed and provide protection from claims that may arise out of or result from Contractor's performance of the Work and Contractor's other obligations under the Contract Documents, whether it is to be performed by Contractor, any Subcontractor or Supplier, or by anyone directly or indirectly employed by any of them to perform any of the Work, or by anyone for whose acts any of them may be liable.
- J. The coverage requirements for specific policies of insurance must be met by such policies, and not by reference to excess or umbrella insurance provided in other policies.

6.04 *Owner's Liability Insurance*

- A. In addition to the insurance required to be provided by Contractor under Paragraph 6.03, Owner, at Owner's option, may purchase and maintain at Owner's expense Owner's own liability insurance as will protect Owner against claims which may arise from operations under the Contract Documents.
- B. Owner's liability policies, if any, operate separately and independently from policies required to be provided by Contractor, and Contractor cannot rely upon Owner's liability policies for any of Contractor's obligations to the Owner, Engineer, or third parties.

6.05 *Property Insurance*

- A. *Builder's Risk:* Unless otherwise provided in the Supplementary Conditions, Contractor shall purchase and maintain builder's risk insurance upon the Work on a completed value basis, in the amount of the full insurable replacement cost thereof (subject to such deductible amounts as may be provided in the Supplementary Conditions or required by Laws and Regulations). This insurance shall:
 - 1. Include the Owner and Contractor as named insureds, and all Subcontractors, and any individuals or entities required by the Supplementary Conditions to be insured under such builder's risk policy, as insureds or named insureds. For purposes of the remainder of this Paragraph 6.05, Paragraphs 6.06 and 6.07, and any corresponding Supplementary Conditions, the parties required to be insured shall collectively be referred to as "insureds."
 - 2. be written on a builder's risk "all risk" policy form that shall at least include insurance for physical loss or damage to the Work, temporary buildings, falsework, and materials and equipment in transit, and shall insure against at least the following perils or causes of loss: fire; lightning; windstorm; riot; civil commotion; terrorism; vehicle impact; aircraft; smoke; theft; vandalism and malicious mischief; mechanical breakdown, boiler explosion, and artificially generated electric current; earthquake; volcanic activity, and other earth movement; flood; collapse; explosion; debris removal; demolition occasioned by enforcement of Laws and Regulations; water damage (other than that caused by flood); and such other perils or causes of loss as may be specifically required by the Supplementary Conditions. If insurance against mechanical breakdown, boiler explosion, and artificially generated electric current; earthquake; volcanic activity, and other earth movement; or flood, are not commercially available under builder's risk policies, by endorsement or otherwise, such insurance may be provided through other insurance policies acceptable to Owner and Contractor.
 - 3. cover, as insured property, at least the following: (a) the Work and all materials, supplies, machinery, apparatus, equipment, fixtures, and other property of a similar nature that are to be incorporated into or used in the preparation, fabrication, construction, erection, or completion of the Work, including Owner-furnished or assigned property; (b) spare parts inventory required within the scope of the Contract; and (c) temporary works which are not intended to form part of the permanent constructed Work but which are intended to provide working access to the Site, or to the Work under construction, or which are intended to provide temporary support for the Work under construction, including scaffolding, form work, fences, shoring, falsework, and temporary structures.
 - 4. cover expenses incurred in the repair or replacement of any insured property (including but not limited to fees and charges of engineers and architects).

5. extend to cover damage or loss to insured property while in temporary storage at the Site or in a storage location outside the Site (but not including property stored at the premises of a manufacturer or Supplier).
 6. extend to cover damage or loss to insured property while in transit.
 7. allow for partial occupation or use of the Work by Owner, such that those portions of the Work that are not yet occupied or used by Owner shall remain covered by the builder's risk Insurance.
 8. allow for the waiver of the insurer's subrogation rights, as set forth below.
 9. provide primary coverage for all losses and damages caused by the perils or causes of loss covered.
 10. not include a co-insurance clause.
 11. include an exception for ensuing losses from physical damage or loss with respect to any defective workmanship, design, or materials exclusions.
 12. include performance/hot testing and start-up.
 13. be maintained in effect, subject to the provisions herein regarding Substantial Completion and partial occupancy or use of the Work by Owner, until the Work is complete.
- B. *Notice of Cancellation or Change:* All the policies of insurance (and the certificates or other evidence thereof) required to be purchased and maintained in accordance with this Paragraph 6.05 will contain a provision or endorsement that the coverage afforded will not be canceled or materially changed or renewal refused until at least 10 days prior written notice has been given to the purchasing policyholder. Within three days of receipt of any such written notice, the purchasing policyholder shall provide a copy of the notice to each other insured.
- C. *Deductibles:* The purchaser of any required builder's risk or property insurance shall pay for costs not covered because of the application of a policy deductible.
- D. *Partial Occupancy or Use by Owner:* If Owner will occupy or use a portion or portions of the Work prior to Substantial Completion of all the Work as provided in Paragraph 15.04, then Owner (directly, if it is the purchaser of the builder's risk policy, or through Contractor) will provide notice of such occupancy or use to the builder's risk insurer. The builder's risk insurance shall not be canceled or permitted to lapse on account of any such partial use or occupancy; rather, those portions of the Work that are occupied or used by Owner may come off the builder's risk policy, while those portions of the Work not yet occupied or used by Owner shall remain covered by the builder's risk insurance.
- E. *Additional Insurance:* If Contractor elects to obtain other special insurance to be included in or supplement the builder's risk or property insurance policies provided under this Paragraph 6.05, it may do so at Contractor's expense.
- F. *Insurance of Other Property:* If the express insurance provisions of the Contract do not require or address the insurance of a property item or interest, such as tools, construction equipment, or other personal property owned by Contractor, a Subcontractor, or an employee of Contractor or a Subcontractor, then the entity or individual owning such property item will be responsible for deciding whether to insure it, and if so in what amount.

6.06 *Waiver of Rights*

- A. All policies purchased in accordance with Paragraph 6.05, expressly including the builder's risk policy, shall contain provisions to the effect that in the event of payment of any loss or damage the insurers will have no rights of recovery against any Insureds thereunder, or against Engineer or its consultants, or their officers, directors, members, partners, employees, agents, consultants, or subcontractors. Owner and Contractor waive all rights against each other and the respective officers, directors, members, partners, employees, agents, consultants, and subcontractors of each and any of them, for all losses and damages caused by, arising out of, or resulting from any of the perils or causes of loss covered by such policies and any other property insurance applicable to the Work; and, in addition, waive all such rights against Engineer, its consultants, all Subcontractors, all individuals or entities identified in the Supplementary Conditions as insureds, and the officers, directors, members, partners, employees, agents, consultants, and subcontractors of each and any of them, under such policies for losses and damages so caused. None of the above waivers shall extend to the rights that any party making such waiver may have to the proceeds of insurance held by Owner or Contractor as trustee or fiduciary, or otherwise payable under any policy so issued.
- B. Owner waives all rights against Contractor, Subcontractors, and Engineer, and the officers, directors, members, partners, employees, agents, consultants and subcontractors of each and any of them, for:
1. loss due to business interruption, loss of use, or other consequential loss extending beyond direct physical loss or damage to Owner's property or the Work caused by, arising out of, or resulting from fire or other perils whether or not insured by Owner; and
 2. loss or damage to the completed Project or part thereof caused by, arising out of, or resulting from fire or other insured peril or cause of loss covered by any property insurance maintained on the completed Project or part thereof by Owner during partial occupancy or use pursuant to Paragraph 15.04, after Substantial Completion pursuant to Paragraph 15.03, or after final payment pursuant to Paragraph 15.06.
- C. Any insurance policy maintained by Owner covering any loss, damage or consequential loss referred to in Paragraph 6.06.B shall contain provisions to the effect that in the event of payment of any such loss, damage, or consequential loss, the insurers will have no rights of recovery against Contractor, Subcontractors, or Engineer, or the officers, directors, members, partners, employees, agents, consultants, or subcontractors of each and any of them.
- D. Contractor shall be responsible for assuring that the agreement under which a Subcontractor performs a portion of the Work contains provisions whereby the Subcontractor waives all rights against Owner, Contractor, all individuals or entities identified in the Supplementary Conditions as insureds, the Engineer and its consultants, and the officers, directors, members, partners, employees, agents, consultants, and subcontractors of each and any of them, for all losses and damages caused by, arising out of, relating to, or resulting from any of the perils or causes of loss covered by builder's risk insurance and any other property insurance applicable to the Work.

6.07 *Receipt and Application of Property Insurance Proceeds*

- A. Any insured loss under the builder's risk and other policies of insurance required by Paragraph 6.05 will be adjusted and settled with the named insured that purchased the

policy. Such named insured shall act as fiduciary for the other insureds, and give notice to such other insureds that adjustment and settlement of a claim is in progress. Any other insured may state its position regarding a claim for insured loss in writing within 15 days after notice of such claim.

- B. Proceeds for such insured losses may be made payable by the insurer either jointly to multiple insureds, or to the named insured that purchased the policy in its own right and as fiduciary for other insureds, subject to the requirements of any applicable mortgage clause. A named insured receiving insurance proceeds under the builder's risk and other policies of insurance required by Paragraph 6.05 shall distribute such proceeds in accordance with such agreement as the parties in interest may reach, or as otherwise required under the dispute resolution provisions of this Contract or applicable Laws and Regulations.
- C. If no other special agreement is reached, the damaged Work shall be repaired or replaced, the money so received applied on account thereof, and the Work and the cost thereof covered by Change Order, if needed.

ARTICLE 7 – CONTRACTOR'S RESPONSIBILITIES

7.01 *Supervision and Superintendence*

- A. Contractor shall supervise, inspect, and direct the Work competently and efficiently, devoting such attention thereto and applying such skills and expertise as may be necessary to perform the Work in accordance with the Contract Documents. Contractor shall be solely responsible for the means, methods, techniques, sequences, and procedures of construction.
- B. At all times during the progress of the Work, Contractor shall assign a competent resident superintendent who shall not be replaced without written notice to Owner and Engineer except under extraordinary circumstances.

7.02 *Labor; Working Hours*

- A. Contractor shall provide competent, suitably qualified personnel to survey and lay out the Work and perform construction as required by the Contract Documents. Contractor shall at all times maintain good discipline and order at the Site.
- B. Except as otherwise required for the safety or protection of persons or the Work or property at the Site or adjacent thereto, and except as otherwise stated in the Contract Documents, all Work at the Site shall be performed during regular working hours, Monday through Friday. Contractor will not perform Work on a Saturday, Sunday, or any legal holiday. Contractor may perform Work outside regular working hours or on Saturdays, Sundays, or legal holidays only with Owner's written consent, which will not be unreasonably withheld.

7.03 *Services, Materials, and Equipment*

- A. Unless otherwise specified in the Contract Documents, Contractor shall provide and assume full responsibility for all services, materials, equipment, labor, transportation, construction equipment and machinery, tools, appliances, fuel, power, light, heat, telephone, water, sanitary facilities, temporary facilities, and all other facilities and incidentals necessary for the performance, testing, start up, and completion of the Work, whether or not such items are specifically called for in the Contract Documents.
- B. All materials and equipment incorporated into the Work shall be of good quality and new, except as otherwise provided in the Contract Documents. All special warranties and

guarantees required by the Specifications shall expressly run to the benefit of Owner. If required by Engineer, Contractor shall furnish satisfactory evidence (including reports of required tests) as to the source, kind, and quality of materials and equipment.

- C. All materials and equipment shall be stored, applied, installed, connected, erected, protected, used, cleaned, and conditioned in accordance with instructions of the applicable Supplier, except as otherwise may be provided in the Contract Documents.

7.04 "Or Equals"

- A. Whenever an item of material or equipment is specified or described in the Contract Documents by using the name of a proprietary item or the name of a particular Supplier, the Contract Price has been based upon Contractor furnishing such item as specified. The specification or description of such an item is intended to establish the type, function, appearance, and quality required. Unless the specification or description contains or is followed by words reading that no like, equivalent, or "or equal" item is permitted, Contractor may request that Engineer authorize the use of other items of material or equipment, or items from other proposed suppliers under the circumstances described below.
 - 1. If Engineer in its sole discretion determines that an item of material or equipment proposed by Contractor is functionally equal to that named and sufficiently similar so that no change in related Work will be required, Engineer shall deem it an "or equal" item. For the purposes of this paragraph, a proposed item of material or equipment will be considered functionally equal to an item so named if:
 - a. in the exercise of reasonable judgment Engineer determines that:
 - 1) it is at least equal in materials of construction, quality, durability, appearance, strength, and design characteristics;
 - 2) it will reliably perform at least equally well the function and achieve the results imposed by the design concept of the completed Project as a functioning whole;
 - 3) It has a proven record of performance and availability of responsive service; and
 - 4) It is not objectionable to Owner.
 - b. Contractor certifies that, if approved and incorporated into the Work:
 - 1) there will be no increase in cost to the Owner or increase in Contract Times; and
 - 2) it will conform substantially to the detailed requirements of the item named in the Contract Documents.
- B. *Contractor's Expense:* Contractor shall provide all data in support of any proposed "or equal" item at Contractor's expense.
- C. *Engineer's Evaluation and Determination:* Engineer will be allowed a reasonable time to evaluate each "or-equal" request. Engineer may require Contractor to furnish additional data about the proposed "or-equal" item. Engineer will be the sole judge of acceptability. No "or-equal" item will be ordered, furnished, installed, or utilized until Engineer's review is complete and Engineer determines that the proposed item is an "or-equal", which will be evidenced by an approved Shop Drawing or other written communication. Engineer will advise Contractor in writing of any negative determination.

- D. *Effect of Engineer's Determination:* Neither approval nor denial of an "or-equal" request shall result in any change in Contract Price. The Engineer's denial of an "or-equal" request shall be final and binding, and may not be reversed through an appeal under any provision of the Contract Documents.
- E. *Treatment as a Substitution Request:* If Engineer determines that an item of material or equipment proposed by Contractor does not qualify as an "or-equal" item, Contractor may request that Engineer consider the proposed item as a substitute pursuant to Paragraph 7.05.

7.05 *Substitutes*

- A. Unless the specification or description of an item of material or equipment required to be furnished under the Contract Documents contains or is followed by words reading that no substitution is permitted, Contractor may request that Engineer authorize the use of other items of material or equipment under the circumstances described below. To the extent possible such requests shall be made before commencement of related construction at the Site.
 - 1. Contractor shall submit sufficient information as provided below to allow Engineer to determine if the item of material or equipment proposed is functionally equivalent to that named and an acceptable substitute therefor. Engineer will not accept requests for review of proposed substitute items of material or equipment from anyone other than Contractor.
 - 2. The requirements for review by Engineer will be as set forth in Paragraph 7.05.B, as supplemented by the Specifications, and as Engineer may decide is appropriate under the circumstances.
 - 3. Contractor shall make written application to Engineer for review of a proposed substitute item of material or equipment that Contractor seeks to furnish or use. The application:
 - a. shall certify that the proposed substitute item will:
 - 1) perform adequately the functions and achieve the results called for by the general design,
 - 2) be similar in substance to that specified, and
 - 3) be suited to the same use as that specified.
 - b. will state:
 - 1) the extent, if any, to which the use of the proposed substitute item will necessitate a change in Contract Times,
 - 2) whether use of the proposed substitute item in the Work will require a change in any of the Contract Documents (or in the provisions of any other direct contract with Owner for other work on the Project) to adapt the design to the proposed substitute item, and
 - 3) whether incorporation or use of the proposed substitute item in connection with the Work is subject to payment of any license fee or royalty.
 - c. will identify:
 - 1) all variations of the proposed substitute item from that specified, and

- 2) available engineering, sales, maintenance, repair, and replacement services.
 - d. shall contain an itemized estimate of all costs or credits that will result directly or indirectly from use of such substitute item, including but not limited to changes in Contract Price, shared savings, costs of redesign, and claims of other contractors affected by any resulting change.
- B. *Engineer's Evaluation and Determination:* Engineer will be allowed a reasonable time to evaluate each substitute request, and to obtain comments and direction from Owner. Engineer may require Contractor to furnish additional data about the proposed substitute item. Engineer will be the sole judge of acceptability. No substitute will be ordered,

- E. Owner may require the replacement of any Subcontractor, Supplier, or other individual or entity retained by Contractor to perform any part of the Work. Owner also may require Contractor to retain specific replacements; provided, however, that Owner may not require a replacement to which Contractor has a reasonable objection. If Contractor has submitted the identity of certain Subcontractors, Suppliers, or other individuals or entities for acceptance by Owner, and Owner has accepted it (either in writing or by failing to make written objection thereto), then Owner may subsequently revoke the acceptance of any such Subcontractor, Supplier, or other individual or entity so identified solely on the basis of substantive, reasonable objection after due investigation. Contractor shall submit an acceptable replacement for the rejected Subcontractor, Supplier, or other individual or entity.
- F. If Owner requires the replacement of any Subcontractor, Supplier, or other individual or entity retained by Contractor to perform any part of the Work, then Contractor shall be entitled to an adjustment in Contract Price or Contract Times, or both, with respect to the replacement; and Contractor shall initiate a Change Proposal for such adjustment within 30 days of Owner's requirement of replacement.
- G. No acceptance by Owner of any such Subcontractor, Supplier, or other individual or entity, whether initially or as a replacement, shall constitute a waiver of the right of Owner to the completion of the Work in accordance with the Contract Documents.
- H. On a monthly basis Contractor shall submit to Engineer a complete list of all Subcontractors and Suppliers having a direct contract with Contractor, and of all other Subcontractors and Suppliers known to Contractor at the time of submittal.
- I. Contractor shall be fully responsible to Owner and Engineer for all acts and omissions of the Subcontractors, Suppliers, and other individuals or entities performing or furnishing any of the Work just as Contractor is responsible for Contractor's own acts and omissions.
- J. Contractor shall be solely responsible for scheduling and coordinating the work of Subcontractors, Suppliers, and all other individuals or entities performing or furnishing any of the Work.
- K. Contractor shall restrict all Subcontractors, Suppliers, and such other individuals or entities performing or furnishing any of the Work from communicating with Engineer or Owner, except through Contractor or in case of an emergency, or as otherwise expressly allowed herein.
- L. The divisions and sections of the Specifications and the Identifications of any Drawings shall not control Contractor in dividing the Work among Subcontractors or Suppliers or delineating the Work to be performed by any specific trade.
- M. All Work performed for Contractor by a Subcontractor or Supplier shall be pursuant to an appropriate contractual agreement that specifically binds the Subcontractor or Supplier to the applicable terms and conditions of the Contract Documents for the benefit of Owner and Engineer.
- N. Owner may furnish to any Subcontractor or Supplier, to the extent practicable, information about amounts paid to Contractor on account of Work performed for Contractor by the particular Subcontractor or Supplier.

O. Nothing in the Contract Documents:

1. shall create for the benefit of any such Subcontractor, Supplier, or other individual or entity any contractual relationship between Owner or Engineer and any such Subcontractor, Supplier, or other individual or entity; nor
2. shall create any obligation on the part of Owner or Engineer to pay or to see to the payment of any money due any such Subcontractor, Supplier, or other individual or entity except as may otherwise be required by Laws and Regulations.

7.07 *Patent Fees and Royalties*

- A. Contractor shall pay all license fees and royalties and assume all costs incident to the use in the performance of the Work or the incorporation in the Work of any invention, design, process, product, or device which is the subject of patent rights or copyrights held by others. If a particular invention, design, process, product, or device is specified in the Contract Documents for use in the performance of the Work and if, to the actual knowledge of Owner or Engineer, its use is subject to patent rights or copyrights calling for the payment of any license fee or royalty to others, the existence of such rights shall be disclosed by Owner in the Contract Documents.
- B. To the fullest extent permitted by Laws and Regulations, Owner shall indemnify and hold harmless Contractor, and its officers, directors, members, partners, employees, agents, consultants, and subcontractors from and against all claims, costs, losses, and damages (including but not limited to all fees and charges of engineers, architects, attorneys, and other professionals, and all court or arbitration or other dispute resolution costs) arising out of or relating to any infringement of patent rights or copyrights incident to the use in the performance of the Work or resulting from the incorporation in the Work of any invention, design, process, product, or device specified in the Contract Documents, but not identified as being subject to payment of any license fee or royalty to others required by patent rights or copyrights.
- C. To the fullest extent permitted by Laws and Regulations, Contractor shall indemnify and hold harmless Owner and Engineer, and the officers, directors, members, partners, employees, agents, consultants and subcontractors of each and any of them from and against all claims, costs, losses, and damages (including but not limited to all fees and charges of engineers, architects, attorneys, and other professionals and all court or arbitration or other dispute resolution costs) arising out of or relating to any infringement of patent rights or copyrights incident to the use in the performance of the Work or resulting from the incorporation in the Work of any invention, design, process, product, or device not specified in the Contract Documents.

7.08 *Permits*

- A. Unless otherwise provided in the Contract Documents, Contractor shall obtain and pay for all construction permits and licenses. Owner shall assist Contractor, when necessary, in obtaining such permits and licenses. Contractor shall pay all governmental charges and inspection fees necessary for the prosecution of the Work which are applicable at the time of the submission of Contractor's Bid (or when Contractor became bound under a negotiated contract). Owner shall pay all charges of utility owners for connections for providing permanent service to the Work

7.09 *Taxes*

- A. Contractor shall pay all sales, consumer, use, and other similar taxes required to be paid by Contractor in accordance with the Laws and Regulations of the place of the Project which are applicable during the performance of the Work.

7.10 *Laws and Regulations*

- A. Contractor shall give all notices required by and shall comply with all Laws and Regulations applicable to the performance of the Work. Except where otherwise expressly required by applicable Laws and Regulations, neither Owner nor Engineer shall be responsible for monitoring Contractor's compliance with any Laws or Regulations.
- B. If Contractor performs any Work or takes any other action knowing or having reason to know that it is contrary to Laws or Regulations, Contractor shall bear all resulting costs and losses, and shall indemnify and hold harmless Owner and Engineer, and the officers, directors, members, partners, employees, agents, consultants, and subcontractors of each and any of them from and against all claims, costs, losses, and damages (including but not limited to all fees and charges of engineers, architects, attorneys, and other professionals and all court or arbitration or other dispute resolution costs) arising out of or relating to such Work or other action. It shall not be Contractor's responsibility to make certain that the Work described in the Contract Documents is in accordance with Laws and Regulations, but this shall not relieve Contractor of Contractor's obligations under Paragraph 3.03.
- C. Owner or Contractor may give notice to the other party of any changes after the submission of Contractor's Bid (or after the date when Contractor became bound under a negotiated contract) in Laws or Regulations having an effect on the cost or time of performance of the Work, including but not limited to changes in Laws or Regulations having an effect on procuring permits and on sales, use, value-added, consumption, and other similar taxes. If Owner and Contractor are unable to agree on entitlement to or on the amount or extent, if any, of any adjustment in Contract Price or Contract Times resulting from such changes, then within 30 days of such notice Contractor may submit a Change Proposal, or Owner may initiate a Claim.

7.11 *Record Documents*

- A. Contractor shall maintain in a safe place at the Site one printed record copy of all Drawings, Specifications, Addenda, Change Orders, Work Change Directives, Field Orders, written interpretations and clarifications, and approved Shop Drawings. Contractor shall keep such record documents in good order and annotate them to show changes made during construction. These record documents, together with all approved Samples, will be available to Engineer for reference. Upon completion of the Work, Contractor shall deliver these record documents to Engineer.

7.12 *Safety and Protection*

- A. Contractor shall be solely responsible for initiating, maintaining, and supervising all safety precautions and programs in connection with the Work. Such responsibility does not relieve Subcontractors of their responsibility for the safety of persons or property in the performance of their work, nor for compliance with applicable safety Laws and Regulations. Contractor shall take all necessary precautions for the safety of, and shall provide the necessary protection to prevent damage, injury, or loss to:
 - 1. all persons on the Site or who may be affected by the Work;

2. all the Work and materials and equipment to be incorporated therein, whether in storage on or off the Site; and
 3. other property at the Site or adjacent thereto, including trees, shrubs, lawns, walks, pavements, roadways, structures, other work in progress, utilities, and Underground Facilities not designated for removal, relocation, or replacement in the course of construction.
- B. Contractor shall comply with all applicable Laws and Regulations relating to the safety of persons or property, or to the protection of persons or property from damage, injury, or loss; and shall erect and maintain all necessary safeguards for such safety and protection. Contractor shall notify Owner; the owners of adjacent property, Underground Facilities, and other utilities; and other contractors and utility owners performing work at or adjacent to the Site, when prosecution of the Work may affect them, and shall cooperate with them in the protection, removal, relocation, and replacement of their property or work in progress.
 - C. Contractor shall comply with the applicable requirements of Owner's safety programs, if any. The Supplementary Conditions identify any Owner's safety programs that are applicable to the Work.
 - D. Contractor shall inform Owner and Engineer of the specific requirements of Contractor's safety program with which Owner's and Engineer's employees and representatives must comply while at the Site.
 - E. All damage, injury, or loss to any property referred to in Paragraph 7.12.A.2 or 7.12.A.3 caused, directly or indirectly, in whole or in part, by Contractor, any Subcontractor, Supplier, or any other individual or entity directly or indirectly employed by any of them to perform any of the Work, or anyone for whose acts any of them may be liable, shall be remedied by Contractor at its expense (except damage or loss attributable to the fault of Drawings or Specifications or to the acts or omissions of Owner or Engineer or anyone employed by any of them, or anyone for whose acts any of them may be liable, and not attributable, directly or indirectly, in whole or in part, to the fault or negligence of Contractor or any Subcontractor, Supplier, or other individual or entity directly or indirectly employed by any of them).
 - F. Contractor's duties and responsibilities for safety and protection shall continue until such time as all the Work is completed and Engineer has issued a notice to Owner and Contractor in accordance with Paragraph 15.06.B that the Work is acceptable (except as otherwise expressly provided in connection with Substantial Completion).
 - G. Contractor's duties and responsibilities for safety and protection shall resume whenever Contractor or any Subcontractor or Supplier returns to the Site to fulfill warranty or correction obligations, or to conduct other tasks arising from the Contract Documents.

7:13 Safety Representative

- A. Contractor shall designate a qualified and experienced safety representative at the Site whose duties and responsibilities shall be the prevention of accidents and the maintaining and supervising of safety precautions and programs.

7.14 Hazard Communication Programs

- A. Contractor shall be responsible for coordinating any exchange of material safety data sheets or other hazard communication information required to be made available to or

exchanged between or among employers at the Site in accordance with Laws or Regulations.

7.15 *Emergencies*

- A. In emergencies affecting the safety or protection of persons or the Work or property at the Site or adjacent thereto, Contractor is obligated to act to prevent threatened damage, injury, or loss. Contractor shall give Engineer prompt written notice if Contractor believes that any significant changes in the Work or variations from the Contract Documents have been caused thereby or are required as a result thereof. If Engineer determines that a change in the Contract Documents is required because of the action taken by Contractor in response to such an emergency, a Work Change Directive or Change Order will be issued.

7.16 *Shop Drawings, Samples, and Other Submittals*

A. *Shop Drawing and Sample Submittal Requirements:*

1. Before submitting a Shop Drawing or Sample, Contractor shall have:
 - a. reviewed and coordinated the Shop Drawing or Sample with other Shop Drawings and Samples and with the requirements of the Work and the Contract Documents;
 - b. determined and verified all field measurements, quantities, dimensions; specified performance and design criteria, installation requirements, materials, catalog numbers, and similar information with respect thereto;
 - c. determined and verified the suitability of all materials and equipment offered with respect to the indicated application, fabrication, shipping, handling, storage, assembly, and installation pertaining to the performance of the Work; and
 - d. determined and verified all information relative to Contractor's responsibilities for means, methods, techniques, sequences, and procedures of construction, and safety precautions and programs incident thereto.
2. Each submittal shall bear a stamp or specific written certification that Contractor has satisfied Contractor's obligations under the Contract Documents with respect to Contractor's review of that submittal, and that Contractor approves the submittal.
3. With each submittal, Contractor shall give Engineer specific written notice of any variations that the Shop Drawing or Sample may have from the requirements of the Contract Documents. This notice shall be set forth in a written communication separate from the Shop Drawings or Sample submittal; and, in addition, in the case of Shop Drawings by a specific notation made on each Shop Drawing submitted to Engineer for review and approval of each such variation.

- B. *Submittal Procedures for Shop Drawings and Samples:* Contractor shall submit Shop Drawings and Samples to Engineer for review and approval in accordance with the accepted Schedule of Submittals. Each submittal will be identified as Engineer may require.

1. *Shop Drawings:*

- a. Contractor shall submit the number of copies required in the Specifications.
- b. Data shown on the Shop Drawings will be complete with respect to quantities, dimensions, specified performance and design criteria, materials, and similar data to show Engineer the services, materials, and equipment Contractor proposes to

8. Contractor shall perform the Work in compliance with the requirements and commitments set forth in approved Shop Drawings and Samples, subject to the provisions of Paragraph 7.16.D.4.

E. *Resubmittal Procedures:*

1. Contractor shall make corrections required by Engineer and shall return the required number of corrected copies of Shop Drawings and submit, as required, new Samples for review and approval. Contractor shall direct specific attention in writing to revisions other than the corrections called for by Engineer on previous submittals.
2. Contractor shall furnish required submittals with sufficient information and accuracy to obtain required approval of an item with no more than three submittals. Engineer will record Engineer's time for reviewing a fourth or subsequent submittal of a Shop Drawings, sample, or other item requiring approval, and Contractor shall be responsible for Engineer's charges to Owner for such time. Owner may impose a set-off against payments due to Contractor to secure reimbursement for such charges.
3. If Contractor requests a change of a previously approved submittal item, Contractor shall be responsible for Engineer's charges to Owner for its review time, and Owner may impose a set-off against payments due to Contractor to secure reimbursement for such charges, unless the need for such change is beyond the control of Contractor.

7.17 *Contractor's General Warranty and Guarantee*

- A. Contractor warrants and guarantees to Owner that all Work will be in accordance with the Contract Documents and will not be defective. Engineer and its officers, directors, members, partners, employees, agents, consultants, and subcontractors shall be entitled to rely on Contractor's warranty and guarantee.
- B. Contractor's warranty and guarantee hereunder excludes defects or damage caused by:
 1. abuse, modification, or improper maintenance or operation by persons other than Contractor, Subcontractors, Suppliers, or any other individual or entity for whom Contractor is responsible; or
 2. normal wear and tear under normal usage.
- C. Contractor's obligation to perform and complete the Work in accordance with the Contract Documents shall be absolute. None of the following will constitute an acceptance of Work that is not in accordance with the Contract Documents or a release of Contractor's obligation to perform the Work in accordance with the Contract Documents:
 1. observations by Engineer;
 2. recommendation by Engineer or payment by Owner of any progress or final payment;
 3. the issuance of a certificate of Substantial Completion by Engineer or any payment related thereto by Owner;
 4. use or occupancy of the Work or any part thereof by Owner;
 5. any review and approval of a Shop Drawing or Sample submittal;
 6. the issuance of a notice of acceptability by Engineer;
 7. any inspection, test, or approval by others; or
 8. any correction of defective Work by Owner.

- D. If the Contract requires the Contractor to accept the assignment of a contract entered into by Owner, then the specific warranties, guarantees, and correction obligations contained in the assigned contract shall govern with respect to Contractor's performance obligations to Owner for the Work described in the assigned contract.

7.18 *Indemnification*

- A. To the fullest extent permitted by Laws and Regulations, and in addition to any other obligations of Contractor under the Contract or otherwise, Contractor shall indemnify and hold harmless Owner and Engineer, and the officers, directors, members, partners, employees, agents, consultants and subcontractors of each and any of them from and against all claims, costs, losses, and damages (including but not limited to all fees and charges of engineers, architects, attorneys, and other professionals and all court or arbitration or other dispute resolution costs) arising out of or relating to the performance of the Work, provided that any such claim, cost, loss, or damage is attributable to bodily injury, sickness, disease, or death, or to injury to or destruction of tangible property (other than the Work itself), including the loss of use resulting therefrom but only to the extent caused by any negligent act or omission of Contractor, any Subcontractor, any Supplier, or any individual or entity directly or indirectly employed by any of them to perform any of the Work or anyone for whose acts any of them may be liable.
- B. In any and all claims against Owner or Engineer or any of their officers, directors, members, partners, employees, agents, consultants, or subcontractors by any employee (or the survivor or personal representative of such employee) of Contractor, any Subcontractor, any Supplier, or any individual or entity directly or indirectly employed by any of them to perform any of the Work, or anyone for whose acts any of them may be liable, the indemnification obligation under Paragraph 7.18.A shall not be limited in any way by any limitation on the amount or type of damages, compensation, or benefits payable by or for Contractor or any such Subcontractor, Supplier, or other individual or entity under workers' compensation acts, disability benefit acts, or other employee benefit acts.
- C. The indemnification obligations of Contractor under Paragraph 7.18.A shall not extend to the liability of Engineer and Engineer's officers, directors, members, partners, employees, agents, consultants and subcontractors arising out of:
 - 1. the preparation or approval of, or the failure to prepare or approve maps, Drawings, opinions, reports, surveys, Change Orders, designs, or Specifications; or
 - 2. giving directions or instructions, or failing to give them, if that is the primary cause of the injury or damage.

7.19 *Delegation of Professional Design Services*

- A. Contractor will not be required to provide professional design services unless such services are specifically required by the Contract Documents for a portion of the Work or unless such services are required to carry out Contractor's responsibilities for construction means, methods, techniques, sequences and procedures. Contractor shall not be required to provide professional services in violation of applicable Laws and Regulations.
- B. If professional design services or certifications by a design professional related to systems, materials, or equipment are specifically required of Contractor by the Contract Documents, Owner and Engineer will specify all performance and design criteria that such services must satisfy. Contractor shall cause such services or certifications to be provided by a properly licensed professional, whose signature and seal shall appear on all drawings, calculations, specifications, certifications, and other submittals prepared by such professional. Shop

Drawings and other submittals related to the Work designed or certified by such professional, if prepared by others, shall bear such professional's written approval when submitted to Engineer.

- C. Owner and Engineer shall be entitled to rely upon the adequacy, accuracy, and completeness of the services, certifications, or approvals performed by such design professionals, provided Owner and Engineer have specified to Contractor all performance and design criteria that such services must satisfy.
- D. Pursuant to this paragraph, Engineer's review and approval of design calculations and design drawings will be only for the limited purpose of checking for conformance with performance and design criteria given and the design concept expressed in the Contract Documents. Engineer's review and approval of Shop Drawings and other submittals (except design calculations and design drawings) will be only for the purpose stated in Paragraph 7.16.D.1.
- E. Contractor shall not be responsible for the adequacy of the performance or design criteria specified by Owner or Engineer.

ARTICLE 8 – OTHER WORK AT THE SITE

8.01 *Other Work*

- A. In addition to and apart from the Work under the Contract Documents, the Owner may perform other work at or adjacent to the Site. Such other work may be performed by Owner's employees, or through contracts between the Owner and third parties. Owner may also arrange to have third-party utility owners perform work on their utilities and facilities at or adjacent to the Site.
- B. If Owner performs other work at or adjacent to the Site with Owner's employees, or through contracts for such other work, then Owner shall give Contractor written notice thereof prior to starting any such other work. If Owner has advance information regarding the start of any utility work at or adjacent to the Site, Owner shall provide such information to Contractor.
- C. Contractor shall afford each other contractor that performs such other work, each utility owner performing other work, and Owner, if Owner is performing other work with Owner's employees, proper and safe access to the Site, and provide a reasonable opportunity for the introduction and storage of materials and equipment and the execution of such other work. Contractor shall do all cutting, fitting, and patching of the Work that may be required to properly connect or otherwise make its several parts come together and properly integrate with such other work. Contractor shall not endanger any work of others by cutting, excavating, or otherwise altering such work; provided, however, that Contractor may cut or alter others' work with the written consent of Engineer and the others whose work will be affected.
- D. If the proper execution or results of any part of Contractor's Work depends upon work performed by others under this Article 8, Contractor shall inspect such other work and promptly report to Engineer in writing any delays, defects, or deficiencies in such other work that render it unavailable or unsuitable for the proper execution and results of Contractor's Work. Contractor's failure to so report will constitute an acceptance of such other work as fit and proper for integration with Contractor's Work except for latent defects and deficiencies in such other work.

8.02 *Coordination*

- A. If Owner intends to contract with others for the performance of other work at or adjacent to the Site, to perform other work at or adjacent to the Site with Owner's employees, or to arrange to have utility owners perform work at or adjacent to the Site, the following will be set forth in the Supplementary Conditions or provided to Contractor prior to the start of any such other work:
1. the identity of the individual or entity that will have authority and responsibility for coordination of the activities among the various contractors;
 2. an itemization of the specific matters to be covered by such authority and responsibility; and
 3. the extent of such authority and responsibilities.
- B. Unless otherwise provided in the Supplementary Conditions, Owner shall have sole authority and responsibility for such coordination.

8.03 *Legal Relationships*

- A. If, in the course of performing other work at or adjacent to the Site for Owner, the Owner's employees, any other contractor working for Owner, or any utility owner for whom the Owner is responsible causes damage to the Work or to the property of Contractor or its Subcontractors, or delays, disrupts, interferes with, or increases the scope or cost of the performance of the Work, through actions or inaction, then Contractor shall be entitled to an equitable adjustment in the Contract Price or the Contract Times, or both. Contractor must submit any Change Proposal seeking an equitable adjustment in the Contract Price or the Contract Times under this paragraph within 30 days of the damaging, delaying, disrupting, or interfering event. The entitlement to, and extent of, any such equitable adjustment shall take into account information (if any) regarding such other work that was provided to Contractor in the Contract Documents prior to the submittal of the Bid or the final negotiation of the terms of the Contract. When applicable, any such equitable adjustment in Contract Price shall be conditioned on Contractor assigning to Owner all Contractor's rights against such other contractor or utility owner with respect to the damage, delay, disruption, or interference that is the subject of the adjustment. Contractor's entitlement to an adjustment of the Contract Times is conditioned on such adjustment being essential to Contractor's ability to complete the Work within the Contract Times.
- B. Contractor shall take reasonable and customary measures to avoid damaging, delaying, disrupting, or interfering with the work of Owner, any other contractor, or any utility owner performing other work at or adjacent to the Site. If Contractor fails to take such measures and as a result damages, delays, disrupts, or interferes with the work of any such other contractor or utility owner, then Owner may impose a set-off against payments due to Contractor, and assign to such other contractor or utility owner the Owner's contractual rights against Contractor with respect to the breach of the obligations set forth in this paragraph.
- C. When Owner is performing other work at or adjacent to the Site with Owner's employees, Contractor shall be liable to Owner for damage to such other work, and for the reasonable direct delay, disruption, and interference costs incurred by Owner as a result of Contractor's failure to take reasonable and customary measures with respect to Owner's other work. In response to such damage, delay, disruption, or interference, Owner may impose a set-off against payments due to Contractor.

- D. If Contractor damages, delays, disrupts, or interferes with the work of any other contractor, or any utility owner performing other work at or adjacent to the Site, through Contractor's failure to take reasonable and customary measures to avoid such impacts, or if any claim arising out of Contractor's actions, inactions, or negligence in performance of the Work at or adjacent to the Site is made by any such other contractor or utility owner against Contractor, Owner, or Engineer, then Contractor shall (1) promptly attempt to settle the claim as to all parties through negotiations with such other contractor or utility owner, or otherwise resolve the claim by arbitration or other dispute resolution proceeding or at law, and (2) indemnify and hold harmless Owner and Engineer, and the officers, directors, members, partners, employees, agents, consultants and subcontractors of each and any of them from and against any such claims, and against all costs, losses, and damages (including but not limited to all fees and charges of engineers, architects, attorneys, and other professionals and all court or arbitration or other dispute resolution costs) arising out of or relating to such damage, delay, disruption, or interference.

ARTICLE 9 – OWNER'S RESPONSIBILITIES

9.01 *Communications to Contractor*

- A. Except as otherwise provided in these General Conditions, Owner shall issue all communications to Contractor through Engineer.

9.02 *Replacement of Engineer*

- A. Owner may at its discretion appoint an engineer to replace Engineer, provided Contractor makes no reasonable objection to the replacement engineer. The replacement engineer's status under the Contract Documents shall be that of the former Engineer.

9.03 *Furnish Data*

- A. Owner shall promptly furnish the data required of Owner under the Contract Documents.

9.04 *Pay When Due*

- A. Owner shall make payments to Contractor when they are due as provided in the Agreement.

9.05 *Lands and Easements; Reports, Tests, and Drawings*

- A. Owner's duties with respect to providing lands and easements are set forth in Paragraph 5.01.
- B. Owner's duties with respect to providing engineering surveys to establish reference points are set forth in Paragraph 4.03.
- C. Article 5 refers to Owner's identifying and making available to Contractor copies of reports of explorations and tests of conditions at the Site, and drawings of physical conditions relating to existing surface or subsurface structures at the Site.

9.06 *Insurance*

- A. Owner's responsibilities, if any, with respect to purchasing and maintaining liability and property insurance are set forth in Article 6.

9.07 *Change Orders*

- A. Owner's responsibilities with respect to Change Orders are set forth in Article 11.

9.08 *Inspections, Tests, and Approvals*

- A. Owner's responsibility with respect to certain inspections, tests, and approvals is set forth in Paragraph 14.02.B.

9.09 *Limitations on Owner's Responsibilities*

- A. The Owner shall not supervise, direct, or have control or authority over, nor be responsible for, Contractor's means, methods, techniques, sequences, or procedures of construction, or the safety precautions and programs incident thereto, or for any failure of Contractor to comply with Laws and Regulations applicable to the performance of the Work. Owner will not be responsible for Contractor's failure to perform the Work in accordance with the Contract Documents.

9.10 *Undisclosed Hazardous Environmental Condition*

- A. Owner's responsibility in respect to an undisclosed Hazardous Environmental Condition is set forth in Paragraph 5.06.

9.11 *Evidence of Financial Arrangements*

- A. Upon request of Contractor, Owner shall furnish Contractor reasonable evidence that financial arrangements have been made to satisfy Owner's obligations under the Contract Documents (including obligations under proposed changes in the Work).

9.12 *Safety Programs*

- A. While at the Site, Owner's employees and representatives shall comply with the specific applicable requirements of Contractor's safety programs of which Owner has been informed.
- B. Owner shall furnish copies of any applicable Owner safety programs to Contractor.

ARTICLE 10 – ENGINEER'S STATUS DURING CONSTRUCTION

10.01 *Owner's Representative*

- A. Engineer will be Owner's representative during the construction period. The duties and responsibilities and the limitations of authority of Engineer as Owner's representative during construction are set forth in the Contract.

10.02 *Visits to Site*

- A. Engineer will make visits to the Site at intervals appropriate to the various stages of construction as Engineer deems necessary in order to observe as an experienced and qualified design professional the progress that has been made and the quality of the various aspects of Contractor's executed Work. Based on information obtained during such visits and observations, Engineer, for the benefit of Owner, will determine, in general, if the Work is proceeding in accordance with the Contract Documents. Engineer will not be required to make exhaustive or continuous inspections on the Site to check the quality or quantity of the Work. Engineer's efforts will be directed toward providing for Owner a greater degree of confidence that the completed Work will conform generally to the Contract Documents. On the basis of such visits and observations, Engineer will keep Owner informed of the progress of the Work and will endeavor to guard Owner against defective Work.
- B. Engineer's visits and observations are subject to all the limitations on Engineer's authority and responsibility set forth in Paragraph 10.08. Particularly, but without limitation, during

or as a result of Engineer's visits or observations of Contractor's Work, Engineer will not supervise, direct, control, or have authority over or be responsible for Contractor's means, methods, techniques, sequences, or procedures of construction, or the safety precautions and programs incident thereto, or for any failure of Contractor to comply with Laws and Regulations applicable to the performance of the Work.

10.03 *Project Representative*

- A. If Owner and Engineer have agreed that Engineer will furnish a Resident Project Representative to represent Engineer at the Site and assist Engineer in observing the progress and quality of the Work, then the authority and responsibilities of any such Resident Project Representative will be as provided in the Supplementary Conditions, and limitations on the responsibilities thereof will be as provided in Paragraph 10.08. If Owner designates another representative or agent to represent Owner at the Site who is not Engineer's consultant, agent, or employee, the responsibilities and authority and limitations thereon of such other individual or entity will be as provided in the Supplementary Conditions.

10.04 *Rejecting Defective Work*

- A. Engineer has the authority to reject Work in accordance with Article 14.

10.05 *Shop Drawings, Change Orders and Payments*

- A. Engineer's authority, and limitations thereof, as to Shop Drawings and Samples, are set forth in Paragraph 7.16.
- B. Engineer's authority, and limitations thereof, as to design calculations and design drawings submitted in response to a delegation of professional design services, if any, are set forth in Paragraph 7.19.
- C. Engineer's authority as to Change Orders is set forth in Article 11.
- D. Engineer's authority as to Applications for Payment is set forth in Article 15.

10.06 *Determinations for Unit Price Work*

- A. Engineer will determine the actual quantities and classifications of Unit Price Work performed by Contractor as set forth in Paragraph 13.03.

10.07 *Decisions on Requirements of Contract Documents and Acceptability of Work*

- A. Engineer will render decisions regarding the requirements of the Contract Documents, and judge the acceptability of the Work, pursuant to the specific procedures set forth herein for initial interpretations, Change Proposals, and acceptance of the Work. In rendering such decisions and judgments, Engineer will not show partiality to Owner or Contractor, and will not be liable to Owner, Contractor, or others in connection with any proceedings, interpretations, decisions, or judgments conducted or rendered in good faith.

10.08 *Limitations on Engineer's Authority and Responsibilities*

- A. Neither Engineer's authority or responsibility under this Article 10 or under any other provision of the Contract, nor any decision made by Engineer in good faith either to exercise or not exercise such authority or responsibility or the undertaking, exercise, or performance of any authority or responsibility by Engineer, shall create, impose, or give rise to any duty in contract, tort, or otherwise owed by Engineer to Contractor, any Subcontractor, any Supplier, any other individual or entity, or to any surety for or employee or agent of any of them.

- B. Engineer will not supervise, direct, control, or have authority over or be responsible for Contractor's means, methods, techniques, sequences, or procedures of construction, or the safety precautions and programs incident thereto, or for any failure of Contractor to comply with Laws and Regulations applicable to the performance of the Work. Engineer will not be responsible for Contractor's failure to perform the Work in accordance with the Contract Documents.
- C. Engineer will not be responsible for the acts or omissions of Contractor or of any Subcontractor, any Supplier, or of any other individual or entity performing any of the Work.
- D. Engineer's review of the final Application for Payment and accompanying documentation and all maintenance and operating instructions, schedules, guarantees, bonds, certificates of inspection, tests and approvals, and other documentation required to be delivered by Paragraph 15.06.A will only be to determine generally that their content complies with the requirements of, and in the case of certificates of inspections, tests, and approvals, that the results certified indicate compliance with the Contract Documents.
- E. The limitations upon authority and responsibility set forth in this Paragraph 10.08 shall also apply to the Resident Project Representative, if any.

10.09 Compliance with Safety Program

- A. While at the Site, Engineer's employees and representatives will comply with the specific applicable requirements of Owner's and Contractor's safety programs (if any) of which Engineer has been informed.

ARTICLE 11 – AMENDING THE CONTRACT DOCUMENTS; CHANGES IN THE WORK

11.01 Amending and Supplementing Contract Documents

- A. The Contract Documents may be amended or supplemented by a Change Order, a Work Change Directive, or a Field Order.
 - 1. *Change Orders:*
 - a. If an amendment or supplement to the Contract Documents includes a change in the Contract Price or the Contract Times, such amendment or supplement must be set forth in a Change Order. A Change Order also may be used to establish amendments and supplements of the Contract Documents that do not affect the Contract Price or Contract Times.
 - b. Owner and Contractor may amend those terms and conditions of the Contract Documents that do not involve (1) the performance or acceptability of the Work, (2) the design (as set forth in the Drawings, Specifications, or otherwise), or (3) other engineering or technical matters, without the recommendation of the Engineer. Such an amendment shall be set forth in a Change Order.
 - 2. *Work Change Directives:* A Work Change Directive will not change the Contract Price or the Contract Times but is evidence that the parties expect that the modification ordered or documented by a Work Change Directive will be incorporated in a subsequently issued Change Order, following negotiations by the parties as to the Work Change Directive's effect, if any, on the Contract Price and Contract Times; or, if negotiations are unsuccessful, by a determination under the terms of the Contract Documents governing adjustments, expressly including Paragraph 11.04 regarding change of Contract Price. Contractor must submit any Change Proposal seeking an

adjustment of the Contract Price or the Contract Times, or both, no later than 30 days after the completion of the Work set out in the Work Change Directive. Owner must submit any Claim seeking an adjustment of the Contract Price or the Contract Times, or both, no later than 60 days after issuance of the Work Change Directive.

3. *Field Orders:* Engineer may authorize minor changes in the Work if the changes do not involve an adjustment in the Contract Price or the Contract Times and are compatible with the design concept of the completed Project as a functioning whole as indicated by the Contract Documents. Such changes will be accomplished by a Field Order and will be binding on Owner and also on Contractor, which shall perform the Work involved promptly. If Contractor believes that a Field Order justifies an adjustment in the Contract Price or Contract Times, or both, then before proceeding with the Work at issue, Contractor shall submit a Change Proposal as provided herein.

11.02 *Owner-Authorized Changes in the Work*

- A. Without invalidating the Contract and without notice to any surety, Owner may, at any time or from time to time, order additions, deletions, or revisions in the Work. Such changes shall be supported by Engineer's recommendation, to the extent the change involves the design (as set forth in the Drawings, Specifications, or otherwise), or other engineering or technical matters. Such changes may be accomplished by a Change Order, if Owner and Contractor have agreed as to the effect, if any, of the changes on Contract Times or Contract Price; or by a Work Change Directive. Upon receipt of any such document, Contractor shall promptly proceed with the Work involved; or, in the case of a deletion in the Work, promptly cease construction activities with respect to such deleted Work. Added or revised Work shall be performed under the applicable conditions of the Contract Documents. Nothing in this paragraph shall obligate Contractor to undertake work that Contractor reasonably concludes cannot be performed in a manner consistent with Contractor's safety obligations under the Contract Documents or Laws and Regulations.

11.03 *Unauthorized Changes in the Work*

- A. Contractor shall not be entitled to an increase in the Contract Price or an extension of the Contract Times with respect to any work performed that is not required by the Contract Documents, as amended, modified, or supplemented, except in the case of an emergency as provided in Paragraph 7.15 or in the case of uncovering Work as provided in Paragraph 14.05.

11.04 *Change of Contract Price*

- A. The Contract Price may only be changed by a Change Order. Any Change Proposal for an adjustment in the Contract Price shall comply with the provisions of Paragraph 11.06. Any Claim for an adjustment of Contract Price shall comply with the provisions of Article 12.
- B. An adjustment in the Contract Price will be determined as follows:
 1. where the Work involved is covered by unit prices contained in the Contract Documents, then by application of such unit prices to the quantities of the items involved (subject to the provisions of Paragraph 13.03); or
 2. where the Work involved is not covered by unit prices contained in the Contract Documents, then by a mutually agreed lump sum (which may include an allowance for overhead and profit not necessarily in accordance with Paragraph 11.04.C.2); or
 3. where the Work involved is not covered by unit prices contained in the Contract Documents and the parties do not reach mutual agreement to a lump sum, then on

the basis of the Cost of the Work (determined as provided in Paragraph 13.01) plus a Contractor's fee for overhead and profit (determined as provided in Paragraph 11.04.C).

- C. *Contractor's Fee:* When applicable, the Contractor's fee for overhead and profit shall be determined as follows:
1. a mutually acceptable fixed fee; or
 2. if a fixed fee is not agreed upon, then a fee based on the following percentages of the various portions of the Cost of the Work:
 - a. for costs incurred under Paragraphs 13.01.B.1 and 13.01.B.2, the Contractor's fee shall be 15 percent;
 - b. for costs incurred under Paragraph 13.01.B.3, the Contractor's fee shall be five percent;
 - c. where one or more tiers of subcontracts are on the basis of Cost of the Work plus a fee and no fixed fee is agreed upon, the intent of Paragraphs 11.04.C.2.a and 11.04.C.2.b is that the Contractor's fee shall be based on: (1) a fee of 15 percent of the costs incurred under Paragraphs 13.01.A.1 and 13.01.A.2 by the Subcontractor that actually performs the Work, at whatever tier, and (2) with respect to Contractor itself and to any Subcontractors of a tier higher than that of the Subcontractor that actually performs the Work, a fee of five percent of the amount (fee plus underlying costs incurred) attributable to the next lower tier Subcontractor; provided, however, that for any such subcontracted work the maximum total fee to be paid by Owner shall be no greater than 27 percent of the costs incurred by the Subcontractor that actually performs the work;
 - d. no fee shall be payable on the basis of costs itemized under Paragraphs 13.01.B.4, 13.01.B.5, and 13.01.C;
 - e. the amount of credit to be allowed by Contractor to Owner for any change which results in a net decrease in cost will be the amount of the actual net decrease in cost plus a deduction in Contractor's fee by an amount equal to five percent of such net decrease; and
 - f. when both additions and credits are involved in any one change, the adjustment in Contractor's fee shall be computed on the basis of the net change in accordance with Paragraphs 11.04.C.2.a through 11.04.C.2.e, inclusive.

11.05 *Change of Contract Times*

- A. The Contract Times may only be changed by a Change Order. Any Change Proposal for an adjustment in the Contract Times shall comply with the provisions of Paragraph 11.06. Any Claim for an adjustment in the Contract Times shall comply with the provisions of Article 12.
- B. An adjustment of the Contract Times shall be subject to the limitations set forth in Paragraph 4.05, concerning delays in Contractor's progress.

11.06 *Change Proposals*

- A. Contractor shall submit a Change Proposal to Engineer to request an adjustment in the Contract Times or Contract Price; appeal an initial decision by Engineer concerning the requirements of the Contract Documents or relating to the acceptability of the Work under the Contract Documents; contest a set-off against payment due; or seek other relief under

the Contract. The Change Proposal shall specify any proposed change in Contract Times or Contract Price, or both, or other proposed relief, and explain the reason for the proposed change, with citations to any governing or applicable provisions of the Contract Documents.

1. *Procedures:* Contractor shall submit each Change Proposal to Engineer promptly (but in no event later than 30 days) after the start of the event giving rise thereto, or after such initial decision. The Contractor shall submit supporting data, including the proposed change in Contract Price or Contract Time (if any); to the Engineer and Owner within 15 days after the submittal of the Change Proposal. The supporting data shall be accompanied by a written statement that the supporting data are accurate and complete, and that any requested time or price adjustment is the entire adjustment to which Contractor believes it is entitled as a result of said event. Engineer will advise Owner regarding the Change Proposal, and consider any comments or response from Owner regarding the Change Proposal.
 2. *Engineer's Action:* Engineer will review each Change Proposal and, within 30 days after receipt of the Contractor's supporting data, either deny the Change Proposal in whole, approve it in whole, or deny it in part and approve it in part. Such actions shall be in writing, with a copy provided to Owner and Contractor. If Engineer does not take action on the Change Proposal within 30 days, then either Owner or Contractor may at any time thereafter submit a letter to the other party indicating that as a result of Engineer's inaction the Change Proposal is deemed denied, thereby commencing the time for appeal of the denial under Article 12.
 3. *Binding Decision:* Engineer's decision will be final and binding upon Owner and Contractor, unless Owner or Contractor appeals the decision by filing a Claim under Article 12.
- B. *Resolution of Certain Change Proposals:* If the Change Proposal does not involve the design (as set forth in the Drawings, Specifications, or otherwise), the acceptability of the Work, or other engineering or technical matters, then Engineer will notify the parties that the Engineer is unable to resolve the Change Proposal. For purposes of further resolution of such a Change Proposal, such notice shall be deemed a denial, and Contractor may choose to seek resolution under the terms of Article 12.

11.07 Execution of Change Orders

- A. Owner and Contractor shall execute appropriate Change Orders covering:
1. changes in the Contract Price or Contract Times which are agreed to by the parties, including any undisputed sum or amount of time for Work actually performed in accordance with a Work Change Directive;
 2. changes in Contract Price resulting from an Owner set-off, unless Contractor has duly contested such set-off;
 3. changes in the Work which are: (a) ordered by Owner pursuant to Paragraph 11.02, (b) required because of Owner's acceptance of defective Work under Paragraph 14.04 or Owner's correction of defective Work under Paragraph 14.07, or (c) agreed to by the parties, subject to the need for Engineer's recommendation if the change in the Work involves the design (as set forth in the Drawings, Specifications, or otherwise), or other engineering or technical matters; and
 4. changes in the Contract Price or Contract Times, or other changes, which embody the substance of any final and binding results under Paragraph 11.06, or Article 12.

- B. If Owner or Contractor refuses to execute a Change Order that is required to be executed under the terms of this Paragraph 11.07, it shall be deemed to be of full force and effect, as if fully executed.

11.08 *Notification to Surety*

- A. If the provisions of any bond require notice to be given to a surety of any change affecting the general scope of the Work or the provisions of the Contract Documents (including, but not limited to, Contract Price or Contract Times), the giving of any such notice will be Contractor's responsibility. The amount of each applicable bond will be adjusted to reflect the effect of any such change.

ARTICLE 12 – CLAIMS

12.01 *Claims*

- A. *Claims Process:* The following disputes between Owner and Contractor shall be submitted to the Claims process set forth in this Article:
 - 1. Appeals by Owner or Contractor of Engineer's decisions regarding Change Proposals;
 - 2. Owner demands for adjustments in the Contract Price or Contract Times, or other relief under the Contract Documents; and
 - 3. Disputes that Engineer has been unable to address because they do not involve the design (as set forth in the Drawings, Specifications, or otherwise), the acceptability of the Work, or other engineering or technical matters.
- B. *Submittal of Claim:* The party submitting a Claim shall deliver it directly to the other party to the Contract promptly (but in no event later than 30 days) after the start of the event giving rise thereto; in the case of appeals regarding Change Proposals within 30 days of the decision under appeal. The party submitting the Claim shall also furnish a copy to the Engineer, for its information only. The responsibility to substantiate a Claim shall rest with the party making the Claim. In the case of a Claim by Contractor seeking an increase in the Contract Times or Contract Price, or both, Contractor shall certify that the Claim is made in good faith, that the supporting data are accurate and complete, and that to the best of Contractor's knowledge and belief the amount of time or money requested accurately reflects the full amount to which Contractor is entitled.
- C. *Review and Resolution:* The party receiving a Claim shall review it thoroughly, giving full consideration to its merits. The two parties shall seek to resolve the Claim through the exchange of information and direct negotiations. The parties may extend the time for resolving the Claim by mutual agreement. All actions taken on a Claim shall be stated in writing and submitted to the other party, with a copy to Engineer.
- D. *Mediation:*
 - 1. At any time after initiation of a Claim, Owner and Contractor may mutually agree to mediation of the underlying dispute. The agreement to mediate shall stay the Claim submittal and response process.
 - 2. If Owner and Contractor agree to mediation, then after 60 days from such agreement, either Owner or Contractor may unilaterally terminate the mediation process, and the Claim submittal and decision process shall resume as of the date of the termination. If the mediation proceeds but is unsuccessful in resolving the dispute, the Claim

submittal and decision process shall resume as of the date of the conclusion of the mediation, as determined by the mediator.

3. Owner and Contractor shall each pay one-half of the mediator's fees and costs.
- E. *Partial Approval*: If the party receiving a Claim approves the Claim in part and denies it in part, such action shall be final and binding unless within 30 days of such action the other party invokes the procedure set forth in Article 17 for final resolution of disputes.
- F. *Denial of Claim*: If efforts to resolve a Claim are not successful, the party receiving the Claim may deny it by giving written notice of denial to the other party. If the receiving party does not take action on the Claim within 90 days, then either Owner or Contractor may at any time thereafter submit a letter to the other party indicating that as a result of the inaction, the Claim is deemed denied, thereby commencing the time for appeal of the denial. A denial of the Claim shall be final and binding unless within 30 days of the denial the other party invokes the procedure set forth in Article 17 for the final resolution of disputes.
- G. *Final and Binding Results*: If the parties reach a mutual agreement regarding a Claim, whether through approval of the Claim, direct negotiations, mediation, or otherwise; or if a Claim is approved in part and denied in part, or denied in full, and such actions become final and binding; then the results of the agreement or action on the Claim shall be incorporated in a Change Order to the extent they affect the Contract, including the Work, the Contract Times, or the Contract Price.

ARTICLE 13 – COST OF THE WORK; ALLOWANCES; UNIT PRICE WORK

13.01 *Cost of the Work*

- A. *Purposes for Determination of Cost of the Work*: The term Cost of the Work means the sum of all costs necessary for the proper performance of the Work at issue, as further defined below. The provisions of this Paragraph 13.01 are used for two distinct purposes:
 1. To determine Cost of the Work when Cost of the Work is a component of the Contract Price, under cost-plus-fee, time-and-materials, or other cost-based terms; or
 2. To determine the value of a Change Order, Change Proposal, Claim, set-off, or other adjustment in Contract Price. When the value of any such adjustment is determined on the basis of Cost of the Work, Contractor is entitled only to those additional or incremental costs required because of the change in the Work or because of the event giving rise to the adjustment.
- B. *Costs Included*: Except as otherwise may be agreed to in writing by Owner, costs included in the Cost of the Work shall be in amounts no higher than those prevailing in the locality of the Project, shall not include any of the costs itemized in Paragraph 13.01.C, and shall include only the following items:
 1. Payroll costs for employees in the direct employ of Contractor in the performance of the Work under schedules of job classifications agreed upon by Owner and Contractor. Such employees shall include, without limitation, superintendents, foremen, and other personnel employed full time on the Work. Payroll costs for employees not employed full time on the Work shall be apportioned on the basis of their time spent on the Work. Payroll costs shall include, but not be limited to, salaries and wages plus the cost of fringe benefits, which shall include social security contributions, unemployment, excise, and payroll taxes, workers' compensation, health and retirement benefits, bonuses, sick leave, and vacation and holiday pay applicable

thereto. The expenses of performing Work outside of regular working hours, on Saturday, Sunday, or legal holidays, shall be included in the above to the extent authorized by Owner.

2. Cost of all materials and equipment furnished and incorporated in the Work, including costs of transportation and storage thereof, and Suppliers' field services required in connection therewith. All cash discounts shall accrue to Contractor unless Owner deposits funds with Contractor with which to make payments, in which case the cash discounts shall accrue to Owner. All trade discounts, rebates, and refunds and returns from sale of surplus materials and equipment shall accrue to Owner, and Contractor shall make provisions so that they may be obtained.
3. Payments made by Contractor to Subcontractors for Work performed by Subcontractors. If required by Owner, Contractor shall obtain competitive bids from subcontractors acceptable to Owner and Contractor and shall deliver such bids to Owner, who will then determine, with the advice of Engineer, which bids, if any, will be acceptable. If any subcontract provides that the Subcontractor is to be paid on the basis of Cost of the Work plus a fee, the Subcontractor's Cost of the Work and fee shall be determined in the same manner as Contractor's Cost of the Work and fee as provided in this Paragraph 13.01.
4. Costs of special consultants (including but not limited to engineers, architects, testing laboratories, surveyors, attorneys, and accountants) employed for services specifically related to the Work.
5. Supplemental costs including the following:
 - a. The proportion of necessary transportation, travel, and subsistence expenses of Contractor's employees incurred in discharge of duties connected with the Work.
 - b. Cost, including transportation and maintenance, of all materials, supplies, equipment, machinery, appliances, office, and temporary facilities at the Site, and hand tools not owned by the workers, which are consumed in the performance of the Work, and cost, less market value, of such items used but not consumed which remain the property of Contractor.
 - c. Rentals of all construction equipment and machinery, and the parts thereof, whether rented from Contractor or others in accordance with rental agreements approved by Owner with the advice of Engineer, and the costs of transportation, loading, unloading, assembly, dismantling, and removal thereof. All such costs shall be in accordance with the terms of said rental agreements. The rental of any such equipment, machinery, or parts shall cease when the use thereof is no longer necessary for the Work.
 - d. Sales, consumer, use, and other similar taxes related to the Work, and for which Contractor is liable, as imposed by Laws and Regulations.
 - e. Deposits lost for causes other than negligence of Contractor, any Subcontractor, or anyone directly or indirectly employed by any of them or for whose acts any of them may be liable, and royalty payments and fees for permits and licenses.
 - f. Losses and damages (and related expenses) caused by damage to the Work, not compensated by insurance or otherwise, sustained by Contractor in connection with the performance of the Work (except losses and damages within the deductible amounts of property insurance established in accordance with Paragraph 6.05), provided such losses and damages have resulted from causes

other than the negligence of Contractor, any Subcontractor, or anyone directly or indirectly employed by any of them or for whose acts any of them may be liable. Such losses shall include settlements made with the written consent and approval of Owner. No such losses, damages, and expenses shall be included in the Cost of the Work for the purpose of determining Contractor's fee.

- g. The cost of utilities, fuel, and sanitary facilities at the Site.
- h. Minor expenses such as communication service at the Site, express and courier services, and similar petty cash items in connection with the Work.
- i. The costs of premiums for all bonds and insurance that Contractor is required by the Contract Documents to purchase and maintain.

C. *Costs Excluded:* The term Cost of the Work shall not include any of the following items:

- 1. Payroll costs and other compensation of Contractor's officers, executives, principals (of partnerships and sole proprietorships), general managers, safety managers, engineers, architects, estimators, attorneys, auditors, accountants, purchasing and contracting agents, expeditors, timekeepers, clerks, and other personnel employed by Contractor, whether at the Site or in Contractor's principal or branch office for general administration of the Work and not specifically included in the agreed upon schedule of Job classifications referred to in Paragraph 13.01.B.1 or specifically covered by Paragraph 13.01.B.4. The payroll costs and other compensation excluded here are to be considered administrative costs covered by the Contractor's fee.
- 2. Expenses of Contractor's principal and branch offices other than Contractor's office at the Site.
- 3. Any part of Contractor's capital expenses, including interest on Contractor's capital employed for the Work and charges against Contractor for delinquent payments.
- 4. Costs due to the negligence of Contractor, any Subcontractor, or anyone directly or indirectly employed by any of them or for whose acts any of them may be liable, including but not limited to, the correction of defective Work, disposal of materials or equipment wrongly supplied, and making good any damage to property.
- 5. Other overhead or general expense costs of any kind and the costs of any item not specifically and expressly included in Paragraph 13.01.B.

D. *Contractor's Fee:* When the Work as a whole is performed on the basis of cost-plus, Contractor's fee shall be determined as set forth in the Agreement. When the value of any Work covered by a Change Order, Change Proposal, Claim, set-off, or other adjustment in Contract Price is determined on the basis of Cost of the Work, Contractor's fee shall be determined as set forth in Paragraph 11.04.C.

E. *Documentation:* Whenever the Cost of the Work for any purpose is to be determined pursuant to this Article 13, Contractor will establish and maintain records thereof in accordance with generally accepted accounting practices and submit in a form acceptable to Engineer an itemized cost breakdown together with supporting data.

13.02 Allowances

A. It is understood that Contractor has included in the Contract Price all allowances so named in the Contract Documents and shall cause the Work so covered to be performed for such sums and by such persons or entities as may be acceptable to Owner and Engineer.

- B. *Cash Allowances*: Contractor agrees that:
 - 1. the cash allowances include the cost to Contractor (less any applicable trade discounts) of materials and equipment required by the allowances to be delivered at the Site, and all applicable taxes; and
 - 2. Contractor's costs for unloading and handling on the Site, labor, installation, overhead, profit, and other expenses contemplated for the cash allowances have been included in the Contract Price and not in the allowances, and no demand for additional payment on account of any of the foregoing will be valid.
- C. *Contingency Allowance*: Contractor agrees that a contingency allowance, if any, is for the sole use of Owner to cover unanticipated costs.
- D. Prior to final payment, an appropriate Change Order will be issued as recommended by Engineer to reflect actual amounts due Contractor on account of Work covered by allowances, and the Contract Price shall be correspondingly adjusted.

13.03 *Unit Price Work*

- A. Where the Contract Documents provide that all or part of the Work is to be Unit Price Work, initially the Contract Price will be deemed to include for all Unit Price Work an amount equal to the sum of the unit price for each separately identified item of Unit Price Work times the estimated quantity of each item as indicated in the Agreement.
- B. The estimated quantities of items of Unit Price Work are not guaranteed and are solely for the purpose of comparison of Bids and determining an initial Contract Price. Payments to Contractor for Unit Price Work will be based on actual quantities.
- C. Each unit price will be deemed to include an amount considered by Contractor to be adequate to cover Contractor's overhead and profit for each separately identified item.
- D. Engineer will determine the actual quantities and classifications of Unit Price Work performed by Contractor. Engineer will review with Contractor the Engineer's preliminary determinations on such matters before rendering a written decision thereon (by recommendation of an Application for Payment or otherwise). Engineer's written decision thereon will be final and binding (except as modified by Engineer to reflect changed factual conditions or more accurate data) upon Owner and Contractor, subject to the provisions of the following paragraph.
- E. Within 30 days of Engineer's written decision under the preceding paragraph, Contractor may submit a Change Proposal, or Owner may file a Claim, seeking an adjustment in the Contract Price if:
 - 1. the quantity of any item of Unit Price Work performed by Contractor differs materially and significantly from the estimated quantity of such item indicated in the Agreement;
 - 2. there is no corresponding adjustment with respect to any other item of Work; and
 - 3. Contractor believes that it is entitled to an increase in Contract Price as a result of having incurred additional expense or Owner believes that Owner is entitled to a decrease in Contract Price, and the parties are unable to agree as to the amount of any such increase or decrease.

ARTICLE 14 – TESTS AND INSPECTIONS; CORRECTION, REMOVAL OR ACCEPTANCE OF DEFECTIVE WORK

14.01 Access to Work

- A. Owner, Engineer, their consultants and other representatives and personnel of Owner, independent testing laboratories, and authorities having jurisdiction will have access to the Site and the Work at reasonable times for their observation, inspection, and testing. Contractor shall provide them proper and safe conditions for such access and advise them of Contractor's safety procedures and programs so that they may comply therewith as applicable.

14.02 Tests, Inspections, and Approvals

- A. Contractor shall give Engineer timely notice of readiness of the Work (or specific parts thereof) for all required inspections and tests, and shall cooperate with inspection and testing personnel to facilitate required inspections and tests.
- B. Owner shall retain and pay for the services of an independent inspector, testing laboratory, or other qualified individual or entity to perform all inspections and tests expressly required by the Contract Documents to be furnished and paid for by Owner, except that costs incurred in connection with tests or inspections of covered Work shall be governed by the provisions of Paragraph 14.05.
- C. If Laws or Regulations of any public body having jurisdiction require any Work (or part thereof) specifically to be inspected, tested, or approved by an employee or other representative of such public body, Contractor shall assume full responsibility for arranging and obtaining such inspections, tests, or approvals, pay all costs in connection therewith, and furnish Engineer the required certificates of inspection or approval.
- D. Contractor shall be responsible for arranging, obtaining, and paying for all inspections and tests required:
 - 1. by the Contract Documents, unless the Contract Documents expressly allocate responsibility for a specific inspection or test to Owner;
 - 2. to attain Owner's and Engineer's acceptance of materials or equipment to be incorporated in the Work;
 - 3. by manufacturers of equipment furnished under the Contract Documents;
 - 4. for testing, adjusting, and balancing of mechanical, electrical, and other equipment to be incorporated into the Work; and
 - 5. for acceptance of materials, mix designs, or equipment submitted for approval prior to Contractor's purchase thereof for incorporation in the Work.

Such inspections and tests shall be performed by independent inspectors, testing laboratories, or other qualified individuals or entities acceptable to Owner and Engineer.

- E. If the Contract Documents require the Work (or part thereof) to be approved by Owner, Engineer, or another designated individual or entity, then Contractor shall assume full responsibility for arranging and obtaining such approvals.
- F. If any Work (or the work of others) that is to be inspected, tested, or approved is covered by Contractor without written concurrence of Engineer, Contractor shall, if requested by Engineer, uncover such Work for observation. Such uncovering shall be at Contractor's expense unless Contractor had given Engineer timely notice of Contractor's intention to

cover the same and Engineer had not acted with reasonable promptness in response to such notice.

14.03 *Defective Work*

- A. *Contractor's Obligation:* It is Contractor's obligation to assure that the Work is not defective.
- B. *Engineer's Authority:* Engineer has the authority to determine whether Work is defective, and to reject defective Work.
- C. *Notice of Defects:* Prompt notice of all defective Work of which Owner or Engineer has actual knowledge will be given to Contractor.
- D. *Correction, or Removal and Replacement:* Promptly after receipt of written notice of defective Work, Contractor shall correct all such defective Work, whether or not fabricated, installed, or completed, or, if Engineer has rejected the defective Work, remove it from the Project and replace it with Work that is not defective.
- E. *Preservation of Warranties:* When correcting defective Work, Contractor shall take no action that would void or otherwise impair Owner's special warranty and guarantee, if any, on said Work.
- F. *Costs and Damages:* In addition to its correction, removal, and replacement obligations with respect to defective Work, Contractor shall pay all claims, costs, losses, and damages arising out of or relating to defective Work, including but not limited to the cost of the inspection, testing, correction, removal, replacement, or reconstruction of such defective Work, fines levied against Owner by governmental authorities because the Work is defective, and the costs of repair or replacement of work of others resulting from defective Work. Prior to final payment, if Owner and Contractor are unable to agree as to the measure of such claims, costs, losses, and damages resulting from defective Work, then Owner may impose a reasonable set-off against payments due under Article 15.

14.04 *Acceptance of Defective Work*

- A. If, instead of requiring correction or removal and replacement of defective Work, Owner prefers to accept it, Owner may do so (subject, if such acceptance occurs prior to final payment, to Engineer's confirmation that such acceptance is in general accord with the design intent and applicable engineering principles, and will not endanger public safety). Contractor shall pay all claims, costs, losses, and damages attributable to Owner's evaluation of and determination to accept such defective Work (such costs to be approved by Engineer as to reasonableness), and for the diminished value of the Work to the extent not otherwise paid by Contractor. If any such acceptance occurs prior to final payment, the necessary revisions in the Contract Documents with respect to the Work shall be incorporated in a Change Order. If the parties are unable to agree as to the decrease in the Contract Price, reflecting the diminished value of Work so accepted, then Owner may impose a reasonable set-off against payments due under Article 15. If the acceptance of defective Work occurs after final payment, Contractor shall pay an appropriate amount to Owner.

14.05 *Uncovering Work*

- A. Engineer has the authority to require additional inspection or testing of the Work, whether or not the Work is fabricated, installed, or completed.

- B. If any Work is covered contrary to the written request of Engineer, then Contractor shall, if requested by Engineer, uncover such Work for Engineer's observation, and then replace the covering, all at Contractor's expense.
- C. If Engineer considers it necessary or advisable that covered Work be observed by Engineer or inspected or tested by others, then Contractor, at Engineer's request, shall uncover, expose, or otherwise make available for observation, inspection, or testing as Engineer may require, that portion of the Work in question, and provide all necessary labor, material, and equipment.
 - 1. If it is found that the uncovered Work is defective, Contractor shall be responsible for all claims, costs, losses, and damages arising out of or relating to such uncovering, exposure, observation, inspection, and testing, and of satisfactory replacement or reconstruction (including but not limited to all costs of repair or replacement of work of others); and pending Contractor's full discharge of this responsibility the Owner shall be entitled to impose a reasonable set-off against payments due under Article 15.
 - 2. If the uncovered Work is not found to be defective, Contractor shall be allowed an increase in the Contract Price or an extension of the Contract Times, or both, directly attributable to such uncovering, exposure, observation, inspection, testing, replacement, and reconstruction. If the parties are unable to agree as to the amount or extent thereof, then Contractor may submit a Change Proposal within 30 days of the determination that the Work is not defective.

14.06 *Owner May Stop the Work*

- A. If the Work is defective, or Contractor fails to supply sufficient skilled workers or suitable materials or equipment, or fails to perform the Work in such a way that the completed Work will conform to the Contract Documents, then Owner may order Contractor to stop the Work, or any portion thereof, until the cause for such order has been eliminated; however, this right of Owner to stop the Work shall not give rise to any duty on the part of Owner to exercise this right for the benefit of Contractor, any Subcontractor, any Supplier, any other individual or entity, or any surety for, or employee or agent of any of them.

14.07 *Owner May Correct Defective Work*

- A. If Contractor fails within a reasonable time after written notice from Engineer to correct defective Work, or to remove and replace rejected Work as required by Engineer, or if Contractor fails to perform the Work in accordance with the Contract Documents, or if Contractor fails to comply with any other provision of the Contract Documents, then Owner may, after seven days written notice to Contractor, correct or remedy any such deficiency.
- B. In exercising the rights and remedies under this Paragraph 14.07, Owner shall proceed expeditiously. In connection with such corrective or remedial action, Owner may exclude Contractor from all or part of the Site, take possession of all or part of the Work and suspend Contractor's services related thereto, and incorporate in the Work all materials and equipment stored at the Site or for which Owner has paid Contractor but which are stored elsewhere. Contractor shall allow Owner, Owner's representatives, agents and employees, Owner's other contractors, and Engineer and Engineer's consultants access to the Site to enable Owner to exercise the rights and remedies under this paragraph:
- C. All claims, costs, losses, and damages incurred or sustained by Owner in exercising the rights and remedies under this Paragraph 14.07 will be charged against Contractor as set-offs against payments due under Article 15. Such claims, costs, losses and damages will

include but not be limited to all costs of repair, or replacement of work of others destroyed or damaged by correction, removal, or replacement of Contractor's defective Work.

- D. Contractor shall not be allowed an extension of the Contract Times because of any delay in the performance of the Work attributable to the exercise by Owner of Owner's rights and remedies under this Paragraph 14.07.

ARTICLE 15 – PAYMENTS TO CONTRACTOR; SET-OFFS; COMPLETION; CORRECTION PERIOD

15.01 Progress Payments

- A. *Basis for Progress Payments:* The Schedule of Values established as provided in Article 2 will serve as the basis for progress payments and will be incorporated into a form of Application for Payment acceptable to Engineer. Progress payments on account of Unit Price Work will be based on the number of units completed during the pay period, as determined under the provisions of Paragraph 13.03. Progress payments for cost-based Work will be based on Cost of the Work completed by Contractor during the pay period.
- B. *Applications for Payments:*
1. At least 20 days before the date established in the Agreement for each progress payment (but not more often than once a month), Contractor shall submit to Engineer for review an Application for Payment filled out and signed by Contractor covering the Work completed as of the date of the Application and accompanied by such supporting documentation as is required by the Contract Documents. If payment is requested on the basis of materials and equipment not incorporated in the Work but delivered and suitably stored at the Site or at another location agreed to in writing, the Application for Payment shall also be accompanied by a bill of sale, invoice, or other documentation warranting that Owner has received the materials and equipment free and clear of all Liens, and evidence that the materials and equipment are covered by appropriate property insurance, a warehouse bond, or other arrangements to protect Owner's interest therein, all of which must be satisfactory to Owner.
 2. Beginning with the second Application for Payment, each Application shall include an affidavit of Contractor stating that all previous progress payments received on account of the Work have been applied on account to discharge Contractor's legitimate obligations associated with prior Applications for Payment.
 3. The amount of retainage with respect to progress payments will be as stipulated in the Agreement.
- C. *Review of Applications:*
1. Engineer will, within 10 days after receipt of each Application for Payment, including each resubmittal, either indicate in writing a recommendation of payment and present the Application to Owner, or return the Application to Contractor indicating in writing Engineer's reasons for refusing to recommend payment. In the latter case, Contractor may make the necessary corrections and resubmit the Application.
 2. Engineer's recommendation of any payment requested in an Application for Payment will constitute a representation by Engineer to Owner, based on Engineer's observations of the executed Work as an experienced and qualified design professional, and on Engineer's review of the Application for Payment and the accompanying data and schedules, that to the best of Engineer's knowledge, information and belief:

- a. the Work has progressed to the point indicated;
 - b. the quality of the Work is generally in accordance with the Contract Documents (subject to an evaluation of the Work as a functioning whole prior to or upon Substantial Completion, the results of any subsequent tests called for in the Contract Documents, a final determination of quantities and classifications for Unit Price Work under Paragraph 13.03, and any other qualifications stated in the recommendation); and
 - c. the conditions precedent to Contractor's being entitled to such payment appear to have been fulfilled in so far as it is Engineer's responsibility to observe the Work.
3. By recommending any such payment Engineer will not thereby be deemed to have represented that:
 - a. inspections made to check the quality or the quantity of the Work as it has been performed have been exhaustive, extended to every aspect of the Work in progress, or involved detailed inspections of the Work beyond the responsibilities specifically assigned to Engineer in the Contract; or
 - b. there may not be other matters or issues between the parties that might entitle Contractor to be paid additionally by Owner or entitle Owner to withhold payment to Contractor.
 4. Neither Engineer's review of Contractor's Work for the purposes of recommending payments nor Engineer's recommendation of any payment, including final payment, will impose responsibility on Engineer:
 - a. to supervise, direct, or control the Work, or
 - b. for the means, methods, techniques, sequences, or procedures of construction, or the safety precautions and programs incident thereto, or
 - c. for Contractor's failure to comply with Laws and Regulations applicable to Contractor's performance of the Work, or
 - d. to make any examination to ascertain how or for what purposes Contractor has used the money paid on account of the Contract Price, or
 - e. to determine that title to any of the Work, materials, or equipment has passed to Owner free and clear of any Liens.
 5. Engineer may refuse to recommend the whole or any part of any payment if, in Engineer's opinion, it would be incorrect to make the representations to Owner stated in Paragraph 15.01.C.2.
 6. Engineer will recommend reductions in payment (set-offs) necessary in Engineer's opinion to protect Owner from loss because:
 - a. the Work is defective, requiring correction or replacement;
 - b. the Contract Price has been reduced by Change Orders;
 - c. Owner has been required to correct defective Work in accordance with Paragraph 14.07, or has accepted defective Work pursuant to Paragraph 14.04;
 - d. Owner has been required to remove or remediate a Hazardous Environmental Condition for which Contractor is responsible; or

- e. Engineer has actual knowledge of the occurrence of any of the events that would constitute a default by Contractor and therefore justify termination for cause under the Contract Documents.

D. *Payment Becomes Due:*

- 1. Ten days after presentation of the Application for Payment to Owner with Engineer's recommendation, the amount recommended (subject to any Owner set-offs) will become due, and when due will be paid by Owner to Contractor.

E. *Reductions in Payment by Owner:*

- 1. In addition to any reductions in payment (set-offs) recommended by Engineer, Owner is entitled to impose a set-off against payment based on any of the following:
 - a. claims have been made against Owner on account of Contractor's conduct in the performance or furnishing of the Work, or Owner has incurred costs, losses, or damages on account of Contractor's conduct in the performance or furnishing of the Work, including but not limited to claims, costs, losses, or damages from workplace injuries, adjacent property damage, non-compliance with Laws and Regulations, and patent infringement;
 - b. Contractor has failed to take reasonable and customary measures to avoid damage, delay, disruption, and interference with other work at or adjacent to the Site;
 - c. Contractor has failed to provide and maintain required bonds or insurance;
 - d. Owner has been required to remove or remediate a Hazardous Environmental Condition for which Contractor is responsible;
 - e. Owner has incurred extra charges or engineering costs related to submittal reviews, evaluations of proposed substitutes, tests and inspections, or return visits to manufacturing or assembly facilities;
 - f. the Work is defective, requiring correction or replacement;
 - g. Owner has been required to correct defective Work in accordance with Paragraph 14.07, or has accepted defective Work pursuant to Paragraph 14.04;
 - h. the Contract Price has been reduced by Change Orders;
 - i. an event that would constitute a default by Contractor and therefore justify a termination for cause has occurred;
 - j. liquidated damages have accrued as a result of Contractor's failure to achieve Milestones, Substantial Completion, or final completion of the Work;
 - k. Liens have been filed in connection with the Work, except where Contractor has delivered a specific bond satisfactory to Owner to secure the satisfaction and discharge of such Liens;
 - l. there are other items entitling Owner to a set off against the amount recommended.
- 2. If Owner imposes any set-off against payment, whether based on its own knowledge or on the written recommendations of Engineer, Owner will give Contractor immediate written notice (with a copy to Engineer) stating the reasons for such action and the specific amount of the reduction, and promptly pay Contractor any amount

remaining after deduction of the amount so withheld. Owner shall promptly pay Contractor the amount so withheld, or any adjustment thereto agreed to by Owner and Contractor, if Contractor remedies the reasons for such action. The reduction imposed shall be binding on Contractor unless it duly submits a Change Proposal contesting the reduction.

3. Upon a subsequent determination that Owner's refusal of payment was not justified, the amount wrongfully withheld shall be treated as an amount due as determined by Paragraph 15.01.C.1 and subject to interest as provided in the Agreement.

15.02 *Contractor's Warranty of Title*

- A. Contractor warrants and guarantees that title to all Work, materials, and equipment furnished under the Contract will pass to Owner free and clear of (1) all Liens and other title defects, and (2) all patent, licensing, copyright, or royalty obligations, no later than seven days after the time of payment by Owner.

15.03 *Substantial Completion*

- A. When Contractor considers the entire Work ready for its intended use Contractor shall notify Owner and Engineer in writing that the entire Work is substantially complete and request that Engineer issue a certificate of Substantial Completion. Contractor shall at the same time submit to Owner and Engineer an initial draft of punch list items to be completed or corrected before final payment.
- B. Promptly after Contractor's notification, Owner, Contractor, and Engineer shall make an inspection of the Work to determine the status of completion. If Engineer does not consider the Work substantially complete, Engineer will notify Contractor in writing giving the reasons therefor.
- C. If Engineer considers the Work substantially complete, Engineer will deliver to Owner a preliminary certificate of Substantial Completion which shall fix the date of Substantial Completion. Engineer shall attach to the certificate a punch list of items to be completed or corrected before final payment. Owner shall have seven days after receipt of the preliminary certificate during which to make written objection to Engineer as to any provisions of the certificate or attached punch list. If, after considering the objections to the provisions of the preliminary certificate, Engineer concludes that the Work is not substantially complete, Engineer will, within 14 days after submission of the preliminary certificate to Owner, notify Contractor in writing that the Work is not substantially complete, stating the reasons therefor. If Owner does not object to the provisions of the certificate, or if despite consideration of Owner's objections Engineer concludes that the Work is substantially complete, then Engineer will, within said 14 days, execute and deliver to Owner and Contractor a final certificate of Substantial Completion (with a revised punch list of items to be completed or corrected) reflecting such changes from the preliminary certificate as Engineer believes justified after consideration of any objections from Owner.
- D. At the time of receipt of the preliminary certificate of Substantial Completion, Owner and Contractor will confer regarding Owner's use or occupancy of the Work following Substantial Completion, review the builder's risk insurance policy with respect to the end of the builder's risk coverage, and confirm the transition to coverage of the Work under a permanent property insurance policy held by Owner. Unless Owner and Contractor agree otherwise in writing, Owner shall bear responsibility for security, operation, protection of the Work, property insurance, maintenance, heat, and utilities upon Owner's use or occupancy of the Work.

- E. After Substantial Completion the Contractor shall promptly begin work on the punch list of items to be completed or corrected prior to final payment. In appropriate cases Contractor may submit monthly Applications for Payment for completed punch list items, following the progress payment procedures set forth above.
- F. Owner shall have the right to exclude Contractor from the Site after the date of Substantial Completion subject to allowing Contractor reasonable access to remove its property and complete or correct items on the punch list.

15.04 *Partial Use or Occupancy*

- A. Prior to Substantial Completion of all the Work, Owner may use or occupy any substantially completed part of the Work which has specifically been identified in the Contract Documents, or which Owner, Engineer, and Contractor agree constitutes a separately functioning and usable part of the Work that can be used by Owner for its intended purpose without significant interference with Contractor's performance of the remainder of the Work, subject to the following conditions:
 - 1. At any time Owner may request in writing that Contractor permit Owner to use or occupy any such part of the Work that Owner believes to be substantially complete. If and when Contractor agrees that such part of the Work is substantially complete, Contractor, Owner, and Engineer will follow the procedures of Paragraph 15.03.A through E for that part of the Work.
 - 2. At any time Contractor may notify Owner and Engineer in writing that Contractor considers any such part of the Work substantially complete and request Engineer to issue a certificate of Substantial Completion for that part of the Work.
 - 3. Within a reasonable time after either such request, Owner, Contractor, and Engineer shall make an inspection of that part of the Work to determine its status of completion. If Engineer does not consider that part of the Work to be substantially complete, Engineer will notify Owner and Contractor in writing giving the reasons therefor. If Engineer considers that part of the Work to be substantially complete, the provisions of Paragraph 15.03 will apply with respect to certification of Substantial Completion of that part of the Work and the division of responsibility in respect thereof and access thereto.
 - 4. No use or occupancy or separate operation of part of the Work may occur prior to compliance with the requirements of Paragraph 6.05 regarding builder's risk or other property insurance.

15.05 *Final Inspection*

- A. Upon written notice from Contractor that the entire Work or an agreed portion thereof is complete, Engineer will promptly make a final inspection with Owner and Contractor and will notify Contractor in writing of all particulars in which this inspection reveals that the Work, or agreed portion thereof, is incomplete or defective. Contractor shall immediately take such measures as are necessary to complete such Work or remedy such deficiencies.

15.06 *Final Payment*

A. *Application for Payment:*

- 1. After Contractor has, in the opinion of Engineer, satisfactorily completed all corrections identified during the final inspection and has delivered, in accordance with the Contract Documents, all maintenance and operating instructions, schedules, guarantees, bonds, certificates or other evidence of insurance, certificates of

inspection, annotated record documents (as provided in Paragraph 7.11), and other documents, Contractor may make application for final payment.

2. The final Application for Payment shall be accompanied (except as previously delivered) by:
 - a. all documentation called for in the Contract Documents;
 - b. consent of the surety, if any, to final payment;
 - c. satisfactory evidence that all title issues have been resolved such that title to all Work, materials, and equipment has passed to Owner free and clear of any Liens or other title defects, or will so pass upon final payment.
 - d. a list of all disputes that Contractor believes are unsettled; and
 - e. complete and legally effective releases or waivers (satisfactory to Owner) of all Lien rights arising out of the Work, and of Liens filed in connection with the Work.
3. In lieu of the releases or waivers of Liens specified in Paragraph 15.06.A.2 and as approved by Owner, Contractor may furnish receipts or releases in full and an affidavit of Contractor that: (a) the releases and receipts include all labor, services, material, and equipment for which a Lien could be filed; and (b) all payrolls, material and equipment bills, and other indebtedness connected with the Work for which Owner might in any way be responsible, or which might in any way result in liens or other burdens on Owner's property, have been paid or otherwise satisfied. If any Subcontractor or Supplier fails to furnish such a release or receipt in full, Contractor may furnish a bond or other collateral satisfactory to Owner to indemnify Owner against any Lien, or Owner at its option may issue joint checks payable to Contractor and specified Subcontractors and Suppliers.

B. *Engineer's Review of Application and Acceptance:*

1. If, on the basis of Engineer's observation of the Work during construction and final inspection, and Engineer's review of the final Application for Payment and accompanying documentation as required by the Contract Documents, Engineer is satisfied that the Work has been completed and Contractor's other obligations under the Contract have been fulfilled, Engineer will, within ten days after receipt of the final Application for Payment, indicate in writing Engineer's recommendation of final payment and present the Application for Payment to Owner for payment. Such recommendation shall account for any set-offs against payment that are necessary in Engineer's opinion to protect Owner from loss for the reasons stated above with respect to progress payments. At the same time Engineer will also give written notice to Owner and Contractor that the Work is acceptable, subject to the provisions of Paragraph 15.07. Otherwise, Engineer will return the Application for Payment to Contractor, indicating in writing the reasons for refusing to recommend final payment, in which case Contractor shall make the necessary corrections and resubmit the Application for Payment.

C. *Completion of Work:* The Work is complete (subject to surviving obligations) when it is ready for final payment as established by the Engineer's written recommendation of final payment.

D. *Payment Becomes Due:* Thirty days after the presentation to Owner of the final Application for Payment and accompanying documentation, the amount recommended by Engineer (less any further sum Owner is entitled to set off against Engineer's recommendation,

including but not limited to set-offs for liquidated damages and set-offs allowed under the provisions above with respect to progress payments) will become due and shall be paid by Owner to Contractor.

15.07 Waiver of Claims

- A. The making of final payment will not constitute a waiver by Owner of claims or rights against Contractor. Owner expressly reserves claims and rights arising from unsettled Liens, from defective Work appearing after final inspection pursuant to Paragraph 15.05, from Contractor's failure to comply with the Contract Documents or the terms of any special guarantees specified therein, from outstanding Claims by Owner, or from Contractor's continuing obligations under the Contract Documents.
- B. The acceptance of final payment by Contractor will constitute a waiver by Contractor of all claims and rights against Owner other than those pending matters that have been duly submitted or appealed under the provisions of Article 17.

15.08 Correction Period

- A. If within one year after the date of Substantial Completion (or such longer period of time as may be prescribed by the terms of any applicable special guarantee required by the Contract Documents, or by any specific provision of the Contract Documents), any Work is found to be defective, or if the repair of any damages to the Site, adjacent areas that Contractor has arranged to use through construction easements or otherwise, and other adjacent areas used by Contractor as permitted by Laws and Regulations, is found to be defective, then Contractor shall promptly, without cost to Owner and in accordance with Owner's written instructions:
 - 1. correct the defective repairs to the Site or such other adjacent areas;
 - 2. correct such defective Work;
 - 3. if the defective Work has been rejected by Owner, remove it from the Project and replace it with Work that is not defective, and
 - 4. satisfactorily correct or repair or remove and replace any damage to other Work, to the work of others, or to other land or areas resulting therefrom.
- B. If Contractor does not promptly comply with the terms of Owner's written instructions, or in an emergency where delay would cause serious risk of loss or damage, Owner may have the defective Work corrected or repaired or may have the rejected Work removed and replaced. Contractor shall pay all claims, costs, losses, and damages (including but not limited to all fees and charges of engineers, architects, attorneys, and other professionals and all court or arbitration or other dispute resolution costs) arising out of or relating to such correction or repair or such removal and replacement (including but not limited to all costs of repair or replacement of work of others).
- C. In special circumstances where a particular item of equipment is placed in continuous service before Substantial Completion of all the Work, the correction period for that item may start to run from an earlier date if so provided in the Specifications.
- D. Where defective Work (and damage to other Work resulting therefrom) has been corrected or removed and replaced under this paragraph, the correction period hereunder with respect to such Work will be extended for an additional period of one year after such correction or removal and replacement has been satisfactorily completed.

- E. Contractor's obligations under this paragraph are in addition to all other obligations and warranties. The provisions of this paragraph shall not be construed as a substitute for, or a waiver of, the provisions of any applicable statute of limitation or repose.

ARTICLE 16 – SUSPENSION OF WORK AND TERMINATION

16.01 *Owner May Suspend Work*

- A. At any time and without cause, Owner may suspend the Work or any portion thereof for a period of not more than 90 consecutive days by written notice to Contractor and Engineer. Such notice will fix the date on which Work will be resumed. Contractor shall resume the Work on the date so fixed. Contractor shall be entitled to an adjustment in the Contract Price or an extension of the Contract Times, or both, directly attributable to any such suspension. Any Change Proposal seeking such adjustments shall be submitted no later than 30 days after the date fixed for resumption of Work.

16.02 *Owner May Terminate for Cause*

- A. The occurrence of any one or more of the following events will constitute a default by Contractor and justify termination for cause:
 - 1. Contractor's persistent failure to perform the Work in accordance with the Contract Documents (including, but not limited to, failure to supply sufficient skilled workers or suitable materials or equipment or failure to adhere to the Progress Schedule);
 - 2. Failure of Contractor to perform or otherwise to comply with a material term of the Contract Documents;
 - 3. Contractor's disregard of Laws or Regulations of any public body having jurisdiction; or
 - 4. Contractor's repeated disregard of the authority of Owner or Engineer.
- B. If one or more of the events identified in Paragraph 16.02.A occurs, then after giving Contractor (and any surety) ten days written notice that Owner is considering a declaration that Contractor is in default and termination of the contract, Owner may proceed to:
 - 1. declare Contractor to be in default, and give Contractor (and any surety) notice that the Contract is terminated; and
 - 2. enforce the rights available to Owner under any applicable performance bond.
- C. Subject to the terms and operation of any applicable performance bond, if Owner has terminated the Contract for cause, Owner may exclude Contractor from the Site, take possession of the Work, incorporate in the Work all materials and equipment stored at the Site or for which Owner has paid Contractor but which are stored elsewhere, and complete the Work as Owner may deem expedient.
- D. Owner may not proceed with termination of the Contract under Paragraph 16.02.B if Contractor within seven days of receipt of notice of intent to terminate begins to correct its failure to perform and proceeds diligently to cure such failure.
- E. If Owner proceeds as provided in Paragraph 16.02.B, Contractor shall not be entitled to receive any further payment until the Work is completed. If the unpaid balance of the Contract Price exceeds the cost to complete the Work, including all related claims, costs, losses, and damages (including but not limited to all fees and charges of engineers, architects, attorneys, and other professionals) sustained by Owner, such excess will be paid to Contractor. If the cost to complete the Work including such related claims, costs, losses,

and damages exceeds such unpaid balance, Contractor shall pay the difference to Owner. Such claims, costs, losses, and damages incurred by Owner will be reviewed by Engineer as to their reasonableness and, when so approved by Engineer, incorporated in a Change Order. When exercising any rights or remedies under this paragraph, Owner shall not be required to obtain the lowest price for the Work performed.

- F. Where Contractor's services have been so terminated by Owner, the termination will not affect any rights or remedies of Owner against Contractor then existing or which may thereafter accrue, or any rights or remedies of Owner against Contractor or any surety under any payment bond or performance bond. Any retention or payment of money due Contractor by Owner will not release Contractor from liability.
- G. If and to the extent that Contractor has provided a performance bond under the provisions of Paragraph 6.01.A, the provisions of that bond shall govern over any inconsistent provisions of Paragraphs 16.02.B and 16.02.D.

16.03 *Owner May Terminate For Convenience*

- A. Upon seven days written notice to Contractor and Engineer, Owner may, without cause and without prejudice to any other right or remedy of Owner, terminate the Contract. In such case, Contractor shall be paid for (without duplication of any items):
 - 1. completed and acceptable Work executed in accordance with the Contract Documents prior to the effective date of termination, including fair and reasonable sums for overhead and profit on such Work;
 - 2. expenses sustained prior to the effective date of termination in performing services and furnishing labor, materials, or equipment as required by the Contract Documents in connection with uncompleted Work, plus fair and reasonable sums for overhead and profit on such expenses; and
 - 3. other reasonable expenses directly attributable to termination, including costs incurred to prepare a termination for convenience cost proposal.
- B. Contractor shall not be paid on account of loss of anticipated overhead, profits, or revenue, or other economic loss arising out of or resulting from such termination.

16.04 *Contractor May Stop Work or Terminate*

- A. If, through no act or fault of Contractor, (1) the Work is suspended for more than 90 consecutive days by Owner or under an order of court or other public authority, or (2) Engineer fails to act on any Application for Payment within 30 days after it is submitted, or (3) Owner fails for 30 days to pay Contractor any sum finally determined to be due, then Contractor may, upon seven days written notice to Owner and Engineer, and provided Owner or Engineer do not remedy such suspension or failure within that time, terminate the contract and recover from Owner payment on the same terms as provided in Paragraph 16.03.
- B. In lieu of terminating the Contract and without prejudice to any other right or remedy, if Engineer has failed to act on an Application for Payment within 30 days after it is submitted, or Owner has failed for 30 days to pay Contractor any sum finally determined to be due, Contractor may, seven days after written notice to Owner and Engineer, stop the Work until payment is made of all such amounts due Contractor, including interest thereon. The provisions of this paragraph are not intended to preclude Contractor from submitting a Change Proposal for an adjustment in Contract Price or Contract Times or otherwise for

expenses or damage directly attributable to Contractor's stopping the Work as permitted by this paragraph.

ARTICLE 17 – FINAL RESOLUTION OF DISPUTES

17.01 *Methods and Procedures*

- A. *Disputes Subject to Final Resolution:* The following disputed matters are subject to final resolution under the provisions of this Article:
1. A timely appeal of an approval in part and denial in part of a Claim, or of a denial in full; and
 2. Disputes between Owner and Contractor concerning the Work or obligations under the Contract Documents, and arising after final payment has been made.
- B. *Final Resolution of Disputes:* For any dispute subject to resolution under this Article, Owner or Contractor may:
1. elect in writing to invoke the dispute resolution process provided for in the Supplementary Conditions; or
 2. agree with the other party to submit the dispute to another dispute resolution process; or
 3. if no dispute resolution process is provided for in the Supplementary Conditions or mutually agreed to, give written notice to the other party of the intent to submit the dispute to a court of competent jurisdiction.

ARTICLE 18 – MISCELLANEOUS

18.01 *Giving Notice*

- A. Whenever any provision of the Contract Documents requires the giving of written notice, it will be deemed to have been validly given if:
1. delivered in person, by a commercial courier service or otherwise, to the individual or to a member of the firm or to an officer of the corporation for which it is intended; or
 2. delivered at or sent by registered or certified mail, postage prepaid, to the last business address known to the sender of the notice.

18.02 *Computation of Times*

- A. When any period of time is referred to in the Contract by days, it will be computed to exclude the first and include the last day of such period. If the last day of any such period falls on a Saturday or Sunday or on a day made a legal holiday by the law of the applicable jurisdiction, such day will be omitted from the computation.

18.03 *Cumulative Remedies*

- A. The duties and obligations imposed by these General Conditions and the rights and remedies available hereunder to the parties hereto are in addition to, and are not to be construed in any way as a limitation of, any rights and remedies available to any or all of them which are otherwise imposed or available by Laws or Regulations, by special warranty or guarantee, or by other provisions of the Contract. The provisions of this paragraph will be as effective as if repeated specifically in the Contract Documents in connection with each particular duty, obligation, right, and remedy to which they apply.

18.04 *Limitation of Damages*

- A. With respect to any and all Change Proposals, Claims, disputes subject to final resolution, and other matters at issue, neither Owner nor Engineer, nor any of their officers, directors, members, partners, employees, agents, consultants, or subcontractors, shall be liable to Contractor for any claims, costs, losses, or damages sustained by Contractor on or in connection with any other project or anticipated project.

18.05 *No Waiver*

- A. A party's non-enforcement of any provision shall not constitute a waiver of that provision, nor shall it affect the enforceability of that provision or of the remainder of this Contract.

18.06 *Survival of Obligations*

- A. All representations, indemnifications, warranties, and guarantees made in, required by, or given in accordance with the Contract, as well as all continuing obligations indicated in the Contract, will survive final payment, completion, and acceptance of the Work or termination or completion of the Contract or termination of the services of Contractor.

18.07 *Controlling Law*

- A. This Contract is to be governed by the law of the state in which the Project is located.

18.08 *Headings*

- A. Article and paragraph headings are inserted for convenience only and do not constitute parts of these General Conditions.

SECTION 00800
SUPPLEMENTARY CONDITIONS

These Supplementary Conditions amend or supplement the Standard General Conditions of the Construction Contract, EJCDC@ C-700 (2013 Edition). All provisions that are not so amended or supplemented remain in full force and effect.

The terms used in these Supplementary Conditions have the meanings stated in the General Conditions except as amended by Article 1. Additional terms used in these Supplementary Conditions have the meanings stated in Article 1 below, which are applicable to both the singular and plural thereof.

The address system used in these Supplementary Conditions is the same as the address system used in the General Conditions, with the prefix "SC" added thereto.

ARTICLE 1 – DEFINITIONS AND TERMINOLOGY

SC 1.01 Add the following language at the end of last sentence of Paragraph 1.01.A.8:

The Change Order form to be used on this Project is provided by the Owner. Owner approval is required before Change Orders are effective.

SC 1.01 Delete Paragraph 1.01.A.15 in its entirety and add the following in its place:

Contract Times - The number of days or the dates stated in the Agreement to complete the Work so that it is ready for final payment as evidenced by Engineer's written recommendation.

SC 1.01 Add the following new language at the end of the last sentence of Paragraph 1.01.A.28:

The authorized representative of Owner assigned to this project is herein, referred to as Project Director.

SC 1.01 Add the following new language at the end of the last sentence of Paragraph 1.01.A.48:

A Work Change directive cannot change Contract Price or Contract Times. Contract Price or Contract time can only be modified with a Change Order.

ARTICLE 2 – PRELIMINARY MATTERS

SC 2.02 Amend the first sentence of Paragraph 2.02.A to read as follows:

A. OWNER shall furnish to the Contractor three (3) copies of the Contract Document (including one fully executed counter part of the Agreement) and one copy in electronic portable document format (PDF).

SC 2.06 Delete Paragraph 2.06.B in its entirety.

ARTICLE 4 – COMMENCEMENT AND PROGRESS OF THE WORK

SECTION 00800
SUPPLEMENTARY CONDITIONS

SC 4.01 Delete Paragraph 4.01.A in its entirety and add the following in its place:

- A. **Notice to Proceed – The OWNER will, after executing the Contract, issue to the Contractor in writing a Notice to Proceed. The beginning of the time allotted for the Contract completion will be 10 days after the date of the Notice to Proceed, or the day on which Work is actually started, whichever occurs first.**

SC. 4.05 Add the following paragraphs immediately after Paragraph 4.05.C.2

- a. **Claims for delays due to abnormal weather conditions shall be handled on a monthly basis. The Contractor shall submit a notice of a claim for a weather delay in each particular month on the last day of that month. Failure to submit notice as required shall constitute a waiver of any claim because of abnormal weather conditions for that month. The Contractor shall submit the notice to the Engineer. Within seven (7) calendar days after the submission of the weather claim notice, the Contractor will submit to the Engineer evidence to justify the claim. This evidence will include the following:**

1. **The days of the month on which the adverse weather occurred. The Contractor will also provide the hours of the day during which the adverse weather occurred at the job site.**

2. **A detailed description of the activities that were affected by the adverse weather.**

3. **A detailed description of claim for the impact of the adverse weather on the critical path of the schedule.**

- b. **The Engineer will review the claim evidence submitted by the Contractor. The Engineer will first compare the adverse weather received during the month against the weather that could have been anticipated for that month, then compare the number of days in the month that exceeded 0.1 inches, then verify that the days requested had greater than 1-inch of precipitation. Anticipated weather for a month will be defined as the average of the weather conditions that have occurred in that month for the years 2014-2016, as documented by the NOAA National Data Center at the St. Augustine Lighthouse.**

ARTICLE 5 – AVAILABILITY OF LANDS; SUBSURFACE AND PHYSICAL CONDITIONS;
HAZARDOUS ENVIRONMENTAL CONDITIONS

SC 5.03 Add the following paragraphs immediately after Paragraph 5.03.A.3

- A. **Report dated June 1, 2017 titled "Final Report of Geotechnical Exploration For Players Club Water Reclamation Facility Ponte Vedra, St. Johns County, Florida" is included in the Specifications**

SECTION 00800
SUPPLEMENTARY CONDITIONS

as Appendix A – Geotechnical Report.

ARTICLE 6 – BONDS AND INSURANCE

SC 6.01 Amend Paragraph A to read as follows:

- A. Contractor shall furnish a public construction bond, in an amount at least equal to the Contract Price, as security for the faithful performance and payment of all of Contractor's obligations under the Contract. The bond shall remain in effect until one year after the date when final payment becomes due or until completion of the correction period specified in Paragraph 15.08, whichever is later, except as provided otherwise by Laws or Regulations, the Supplementary Conditions, or other specific provisions of the Contract. Contractor shall also furnish such other bonds as are required by the Supplementary Conditions or other specific provisions of the Contract.**

SC 6.01 Amend Paragraph F to read as follows:

- F. Upon request, Owner shall provide a copy of the public construction bond to any Subcontractor, Supplier, or other person or entity claiming to have furnished labor or materials used in the performance of the Work.**

SC 6.02 Add the following paragraphs immediately after Paragraph 6.02.J:

- K. The Contractor shall not commence work under this Contract until he/she has obtained all insurance required under this section and such insurance has been approved by the County. All insurance policies shall be issued by companies authorized to do business under the laws of the State of Florida. The Contractor shall furnish proof of Insurance to the County prior to the commencement of operations. The Certificate(s) shall clearly indicate the Contractor has obtained insurance of the type, amount, and classification as required by contract and that no material change or cancellation of the insurance shall be effective without thirty (30) days prior written notice to the County. Certificates shall specifically include the County as Additional Insured for all lines of coverage except Workers' Compensation and Professional Liability. A copy of the endorsement must accompany the certificate. Compliance with the foregoing requirements shall not relieve the Contractor of its liability and obligations under this Contract.**

**Certificate Holder Address:
St. Johns County, a political subdivision of the State of Florida
500 San Sebastian View
St. Augustine, FL 32084**

SECTION 00800
SUPPLEMENTARY CONDITIONS

- SC 6.03 Delete Paragraph 6.03.A. and replace with the following paragraph:
- A. **Workers' Compensation:** The Contractor shall maintain during the life of this Contract, adequate Workers' Compensation Insurance in at least such amounts as are required by the law for all of its per Florida Statute 440.02.
- SC 6.03 Delete paragraph 6.03 B and replace with the following paragraph:
- B. **Comprehensive General Liability:** The Contractor shall maintain during the life of this Contract, Comprehensive General Liability Insurance with minimum limits of \$1,000,000 per occurrence, \$2,000,000 aggregate to protect the Contractor from claims for damages for bodily injury, including wrongful death, as well as from claims of property damages which may arise from any operations under this Contract, whether such operations be by the Contractor or by anyone directly employed by or contracting with the Contractor.
- SC 6.03 Delete paragraph 6.03 C in its entirety.
- SC 6.03 Delete paragraph 6.03 D and replace with the following paragraph:
- D. **Automotive Liability:** The Contractor shall maintain during the life of this Contract, Comprehensive Automobile Liability Insurance with minimum limits of \$2,000,000 combined single limit for bodily injury and property damage liability to protect the Contractor from claims for damages for bodily injury, including the ownership, use, or maintenance of owned and non-owned automobiles, including rented/hired automobiles whether such operations be by the Contractor or by anyone directly or indirectly employed by a Contractor.
- SC 6.03 Delete paragraph 6.03 E and replace with the following paragraph:
- E. **Umbrella or Excess Liability:** The Contractor shall maintain Umbrella or Excess Liability Insurance covering workers compensation, commercial general liability and business auto liability with minimum limits of liability of \$1,000,000.
- SC 6.03 Delete Paragraph 6.03.F in its entirety and replace with the following paragraph:
- F. **Builder's Risk:** The CONTRACTOR shall maintain during the life of this Contract, adequate Builder's Risk Insurance in the amount of the initial contract amount plus the values of subsequent modifications, change orders, and loss of materials supplied or installed by others comprising the value of the entire project at the site on a replacement cost basis.
- SC 6.03 Delete paragraph 6.03 G in its entirety.
- SC 6.03 Delete Paragraph 6.03.H in its entirety and replace with the following paragraph:

SECTION 00800
SUPPLEMENTARY CONDITIONS

- H. **Contractor's professional liability insurance:** The Contractor shall maintain during the life of the contract, Professional Liability or Errors and Omissions Insurance with minimum limits of \$1,000,000, if applicable.

ARTICLE 7 – CONTRACTOR'S RESPONSIBILITIES

SC 7.02 Amend the first sentence of Paragraph 7.02.B by adding 7:00 AM to 5:00 PM.

SC 7.04 Delete Paragraph 7.04 in its entirety and replace with the following paragraph:

- A. **Section 01010 – Summary of Work** describes the methods and means that the Contractor shall submit for approval of all equipment and materials that are not specifically listed as approved manufacturers, products, or equipment on the project. These procedures will be followed. Should the Contractor wish to deviate from the design provided herein, costs for review and approval of these modifications will be borne by the Contractor. The Contractor must submit a request for deviation and acknowledgement that they are responsible for all costs prior to the Engineer reviewing said changes.
- B. For products, materials, or equipment specified by name and which do not include "Engineer Approved Equal" or "Or Equal", there is not an option to provide a substitution and one of the product manufacturers or equipment listed shall be provided.
- C. Any equipment, materials, or products that the Contractor wishes to provide an alternate product, material, or equipment vendor and which are listed in the technical specifications or on the Drawings as "Engineer Approved Equal" or "Or Equal" shall be approved PRIOR to the bid opening. Contractor shall submit all information for approval by the Engineer a minimum of 14-days prior to the bid opening. Substitutions provided after that date will not be accepted or allowed.
1. Provide the following information with the substitutions package for review during the bid phase:
 - a. Name of the material or equipment for which it is to be substituted and a complete description of the proposed substitute, including drawings, cut sheets, performance and testing data, and any other information necessary for the evaluation. Standard brochures are not acceptable. Information shall be specific and detailed for this project.
 - b. Provide a statement comparing the product, material, or equipment with the technical specification or drawings with any deviations, changes, or modifications required clearly outlined.

SECTION 00800
SUPPLEMENTARY CONDITIONS

- c. Provide a list of references of similar sized equipment or installation references for review. At least three separate references shall be provided.
2. Approval of substitutions is strictly at the discretion of the Owner and Engineer.

SC 7.05 Delete Paragraph 7.05 in its entirety.

SC 7.06 Amend Paragraph 7.06.A by adding the following text to the end of the paragraph:

The Contractor shall not award work valued at more than 50 percent of the Contract Price less cost of direct purchased items and the Sales Tax Exemption Agreement to Subcontractor(s), without prior written approval of the OWNER.

SC 7.16 Delete Paragraph 7.16.B. and replace with the following paragraph:

Submittal Procedures for Shop Drawings, Samples and Other Submittals:
Contractor shall submit as per Section 01300 of the Specifications.

SC 7.16 Delete Paragraph 7.16.C in its entirety.

SC 7.16 Amend Paragraph 7.16.E.2 by striking out the following: "three" and replace with:
two

SC 7.16 Amend Paragraph 7.16.E.2 by striking out the following: "fourth" and replace with:
third

ARTICLE 9 – OWNER'S RESPONSIBILITIES

SC 9.13 Add the following new paragraph immediately after Paragraph 9.12.

9.13 Project Director

- A. **The Project Director, unless otherwise directed by the Owner shall perform those duties and discharge those responsibilities allocated to the Project Director as set forth in this Agreement. The Project Director shall be the Owner's representative from the effective date of this Agreement until Final Payment has been made. The Project Director shall be authorized to act on behalf of the Owner only to the extent provided in this Agreement.**
- B. **The Owner and the Contractor shall communicate with each other in the first instance through the Engineer and Project Director.**
- C. **The Project Director shall be the initial interpreter of the requirements of the drawings and specifications and the judge of the performance there**

SECTION 00800
SUPPLEMENTARY CONDITIONS

under by the Contractor. The Project Director shall render written or graphic interpretations necessary for the proper execution or progress of the Work with reasonable promptness on request of the Contractor.

- D. The Engineer and Project Director shall review the Contractor's Applications for Payment and shall certify to the Owner for payment to the Contractor, those amounts then due to the Contractor as provided in this Agreement.
- E. The Project Director shall have authority to reject Work, which is defective or does not conform to the requirements of this Agreement. If the Project Director deems it necessary or advisable, the Project Director shall authority to require additional inspection or testing of the Work for compliance with Contract requirements at Contractor's expense.
- F. The Project Director shall review and approve, or take other appropriate action as necessary, concerning the Contractor's submittals including Product Data and Samples. Such review, approval or other action shall be for the sole purpose of determining conformance with the design concept and information given through the Contract Documents.
- G. The Project Director shall prepare Change Orders and may authorize minor changes in the Work by field order as provided elsewhere herein.
- H. The Project Director shall, upon written request from the Contractor, conduct inspections to determine the date of Substantial Completion and the date of Final Completion, shall receive and forward to the Owner for the Owner's review and records, written warranties and related documents required by this Agreement and shall issue a Final Certificate for Payment upon compliance with the requirements of this Agreement.
- I. The Project Director's decision in matters relating to aesthetic effect shall be final if consistent with the intent of this Agreement.

ARTICLE 15 – PAYMENTS TO CONTRACTOR; SET-OFFS; COMPLETION; CORRECTION PERIOD

SC 15.01 Add the following language at the end of Paragraph 15.01.B.3:

No payments will be made that would deplete the retainage, place in escrow any funds that are required for retainage, or invest the retainage for the benefit of the Contractor.

SC 15.01 Add the following new paragraph immediately after Paragraph 15.01.B.3

4. The Application for Payment form to be used on this Project is supplied by Owner. The OWNER must approve all Applications for Payment before payment is made.

SC 15.01 Delete Paragraph 15.01.D.1 in its entirety and replace with the following:

The Application for Payment with Engineer's recommendations will be

SECTION 00800
SUPPLEMENTARY CONDITIONS

presented to the OWNER and Agency for consideration. If the OWNER finds the Application for Payment acceptable, the recommended amount less any reduction under the provisions of Paragraph 15.01.E will become due twenty (20) days after the Application for Payment is presented to the OWNER, and the OWNER will make payment to the Contractor.

SC 15.02 Amend Paragraph 15.02.A by striking out the following: "~~no later than seven days after the time of payment by Owner~~" and replace with:

no later than the time of payment by OWNER.

SC 16.02 Add the following new paragraphs immediately after Paragraph 16.02.A.4

- 5. fails to make prompt payment to Subcontractors, or for materials or labor;**
- 6. persistently disregards laws, ordinances, rules, regulations or orders of any public authority having jurisdiction; or**
- 7. otherwise substantially violates a material provision of this Agreement,**

SC 16.02 Replace the words **performance bond** with the words **public construction bond** in Paragraph 16.02.B.2

SC 16.02 Replace the words **performance bond** with the words **public construction bond** in Paragraph 16.02.C

SC 16.02 Replace the words **payment bond or performance bond** with the words **public construction bond** in Paragraph 16.02.F.

SC 16.02 Replace the words **payment bond or performance bond** with the words **public construction bond** in Paragraph 16.02.G.

SC 16.03 Add the following new paragraph immediately after Paragraph 16.03.B

- C. The Contractor shall incur no further obligations in connection with the Work and the Contractor shall stop Work when such termination becomes effective. The Contractor shall also terminate outstanding orders and subcontracts. The Contractor shall settle liabilities and claims arising out of the termination of subcontracts and orders. The Owner may direct the Contractor to assign the Contractor's right, title and interest under terminated orders or subcontracts to the Owner or its designee.**
- D. The Contractor shall transfer title and deliver to the Owner such completed or partially completed Work and materials, equipment, parts, fixtures, information and Contract rights as the Contractor has.**
- E. The Contractor shall submit a termination claim to the Project Director specifying the amounts due because of the termination for convenience together with costs, pricing or other data required by the Project Director. If the Contractor fails to file a termination claim within one (1) year from the effective date of termination, the Owner shall pay the Contractor, an**

SECTION 00800
SUPPLEMENTARY CONDITIONS

amount derived in accordance with subparagraph (G) below.

- F. The Owner and the Contractor may agree to compensation, if any, due to the Contractor hereunder.
- G. Absent agreement to the amount due to the Contractor, the Owner shall pay the Contractor the following amounts:
 - 1. Contract prices for labor, materials, equipment, and other services accepted under this Agreement;
 - 2. Reasonable costs incurred in preparing to perform and in performing a portion of the Work prior to termination and not included in (G.1.) or (G.2), and in terminating the Contractor's performance, plus a fair and reasonable allowance for overhead and profit thereon (such profit shall not include anticipated profit or consequential damages); provided, however, that if it appears that the Contractor would have not profited or would have sustained a loss if the entire Contract had been completed, no profit shall be allowed or included and the amount of compensation shall be reduced to reflect the anticipated rate of loss, if any;
 - 3. Reasonable costs of settling and paying claims arising out of the termination of Subcontracts or orders pursuant to Subparagraph 16.03.C of this Paragraph. These costs shall not include amounts paid in accordance with other provisions hereof.
- H. The total sum to be paid the Contractor under this Subparagraph 16.03 shall not exceed the total Contract Price, as properly adjusted, reduced by the amount of payments otherwise made, and shall in no event include duplication of payment.

SC 18.01 : Delete from Paragraph A.2 the words "registered or certified."

SC 18.09 Add the following new paragraph immediately after Paragraph 18.08

18.09 Contractor's Employment Opportunity

- A. The Contractor and all Subcontractors shall not discriminate against any employee or applicant for employment because of race, religion, color, sex, national origin or age.
- B. The Contractor shall take affirmative action to insure that applicants are employed, and that employees are treated during employment without regard to their race, religion, color, sex, national origin or age. Such action shall include, but not be limited to, the following: employment, upgrading, demotion or transfer, recruitment or recruitment advertisement, layoff or termination, rates of pay or other forms of compensation, and selection for training, including apprenticeship. The Contractor agrees to post in conspicuous places, available to employees and applicants for employment, notices setting forth the policies of non-discrimination.

SECTION 00800
SUPPLEMENTARY CONDITIONS

- C. The Contractor and all Subcontractors shall, in all solicitations or advertisements for employees placed by them or on their behalf, state that all qualified applicants shall receive consideration for employment without regard to race, religion, color, sex, national origin or age.

SC 18.10 Add the following new paragraph immediately after Paragraph 18.09

18.10 Apprenticeship Law (Chapter 446, Florida Statutes)

- A. The Contractor shall make a diligent effort to hire for Performance of the Contract a number of apprentices in each occupation which bears to the average number of journeyman in that occupation to be employed in the performance of the Contract, the ratio of at least one (1) apprentice or trainee to every five (5) journeymen.
- B. The Contractor shall, when feasible and except when the number of apprentices or trainees to be hired is fewer than four (4), assure that twenty-five (25) percent of such apprentices or trainees are in their first year of training. Feasibility here involves a consideration of the availability of training opportunities for first year apprentices or trainees, the hazardous nature of the Work for beginning workers, and excessive unemployment of apprentices or trainees in their second or subsequent years of training.
- C. The Contractor, during the performance of the Contract, shall make diligent efforts to employ the number of apprentices or trainees necessary to meet requirements of Subparagraphs a. and b. However, on-the-job training programs shall only be established in non-apprenticable trades or occupations to meet the requirements of this section.
- D. The Contractor agrees to return records of employment, by trade, of the number of apprentices or trainees by first year of training, and the number of journeymen and the wages paid, and hours of work, of such persons on a form as prescribed by the Bureau of Apprenticeship of the Division of Labor at three (3) month intervals. Submission of duplicate copies of forms submitted to the United States Department of Labor shall be sufficient compliance with the provisions of the section.
- E. The Contractor agrees to supply the Bureau of Apprenticeship of the Division of Labor, at three (3) months intervals, a statement describing steps taken toward making diligent effort and containing a breakdown by craft or hours worked and wages paid for first year apprentices or trainees, other apprentices or trainees and journeymen.
- F. The Contractor agrees to insert in any Subcontract under this Agreement the requirements contained in this section. "The term Contractor" as used in such clauses and any Subcontract shall mean the Subcontractor.
- G. Anything herein to the Contrary notwithstanding, Contractor agrees to comply with all of the provisions of Florida Statutes 446 and all regulations prescribed by the Bureau of Apprenticeship of the Division of Labor.

SC 18.11 Add the following new paragraph immediately after Paragraph 18.10.

SECTION 00800
SUPPLEMENTARY CONDITIONS

18.11 Public Records

- A. The cost of reproduction, access to, disclosure, non-disclosure, or exemption of records, data, documents, and/or materials, associated with this Agreement shall be subject to the applicable provisions of the Florida Public Records Law (Chapter 119, Florida Statutes), and other applicable State and Federal provisions. Access to such public records, may not be blocked, thwarted, and/or hindered by placing the public records in the possession of a third party, or an unaffiliated party.
- B. In accordance with Florida law, to the extent that Contractor's performance under this Contract constitutes an act on behalf of the County, Contractor shall comply with all requirements of Florida's public records law. Specifically, if Contractor is expressly authorized, and acts on behalf of the County under this Agreement, Contractor shall:
- (1) Keep and maintain public records that ordinarily and necessarily would be required by the County in order to perform the Services;
 - (2) Upon request from the County's custodian of public records, provide the County with a copy of the requested records or allow the records to be inspected or copied within a reasonable time at a cost that does not exceed the cost as provided in Chapter 119, Florida Statutes, or as otherwise provided by law;
 - (3) Ensure that public records related to this Agreement that are exempt or confidential and exempt from public records disclosure requirements are not disclosed except as authorized by applicable law for the duration of this Agreement and following completion of this Agreement if the Contractor does not transfer the records to the County; and
 - (4) Upon completion of this Agreement, transfer, at no cost, to the County all public records in possession of the Contractor or keep and maintain public records required by the County to perform the Services.
- C. If the Contractor transfers all public records to the County upon completion of this Agreement, the Contractor shall destroy any duplicate public records that are exempt or confidential and exempt from public records disclosure requirements. If the Contractor keeps and maintains public records upon completion of this Agreement, the Contractor shall meet all applicable requirements for retaining public records. All records stored electronically must be provided to the County, upon request from the County's custodian of public records, in a format that is compatible with the County's information technology systems.
- D. Failure by the Contractor to comply with the requirements of this section shall be grounds for immediate, unilateral termination of this Agreement by the County.

IF THE CONTRACTOR HAS QUESTIONS REGARDING THE APPLICATION OF CHAPTER 119, FLORIDA STATUTES, TO ITS DUTY TO PROVIDE PUBLIC RECORDS RELATING TO THIS AGREEMENT, CONTACT THE

SECTION 00800
SUPPLEMENTARY CONDITIONS

**CUSTODIAN OF PUBLIC RECORDS AT: OCA, ATTN: Public Records
Manager, 500 San Sebastian View, St. Augustine, FL 32084, PH: (904) 209-
0805, EMAIL: publicrecords@sjcf.us.**

SUPPLEMENTARY CONDITIONS (CONSTRUCTION)

Florida Department of Environmental Protection

State Revolving Fund Program

Supplementary Conditions

for

Formally Advertised

Construction Procurement

Revised April 2017

**TABLE OF CONTENTS FOR THE FLORIDA DEPARTMENT OF
ENVIRONMENTAL PROTECTION
SUPPLEMENTARY CONDITIONS**

Article Number	Article Title	Page
1	DEFINITIONS	FDEP-1
2	PRIVITY OF AGREEMENT/CONTRACT	FDEP-2
3	PROCUREMENT REQUIREMENTS	FDEP-2
4	RESOLUTION OF PROTESTS AND CLAIMS/DISPUTES	FDEP-2
5	CHANGES TO THE BIDDING AND CONTRACT DOCUMENTS	FDEP-3
6	BONDS AND INSURANCE	FDEP-3
7	AWARD OF AGREEMENT/CONTRACT	FDEP-4
8	ITEMIZED CONSTRUCTION COST BREAKDOWN; CONSTRUCTION AND PAYMENT SCHEDULES	FDEP-4
9	FDEP/USEPA ACCESS TO RECORDS AND PROJECT SITE	FDEP-4
10	DISADVANTAGED BUSINESS ENTERPRISES	FDEP-4
11	DEBARMENT AND SUSPENSION (EXECUTIVE ORDER 12549)	FDEP-5
12	EQUAL EMPLOYMENT OPPORTUNITY (EXECUTIVE ORDER 11246)	FDEP-6
13	IMMIGRATION REFORM AND CONTROL ACT OF 1986 STATE OF FLORIDA EXECUTIVE ORDER 11-116)	FDEP-12
14	ENVIRONMENTAL COMPLIANCE	FDEP-12
15	FEDERAL LABOR STANDARDS PROVISION	FDEP-12
16	AMERICAN IRON AND STEEL PROVISION	FDEP-12
17	PROHIBITED LOCAL GOVERNMENT CONSTRUCTION PREFERENCES	FDEP-12

Appendix	Title	Page
A	CERTIFICATION OF COMPLIANCE WITH THE FLORIDA DEPARTMENT OF ENVIRONMENTAL PROTECTION SUPPLEMENTARY CONDITIONS	FDEP-13
B	GOALS AND TIMETABLES FOR MINORITIES AND FEMALES	FDEP-14
C	FEDERAL LABOR STANDARDS PROVISION	FDEP-15
D	AMERICAN IRON AND STEEL PROVISION	FDEP-23

FLORIDA DEPARTMENT OF ENVIRONMENTAL PROTECTION SUPPLEMENTARY CONDITIONS

The intent of the Florida Department of Environmental Protection (FDEP) Supplementary Conditions is to complement and supplement other provisions of the Bidding Documents. However, if there is any conflict between the FDEP Supplementary Conditions and other provisions of the Bidding Documents, the FDEP Supplementary Conditions shall take precedence over the other provisions except when the other provisions are similar to, but more stringent than, the FDEP Supplementary Conditions. When other provisions of the Bidding Documents are similar to, but more stringent than, the FDEP Supplementary Conditions, the more stringent provisions shall apply.

ARTICLE 1 - DEFINITIONS

Wherever used in these Supplementary Conditions (except in the appendices to these Supplementary Conditions), the following terms have the meanings indicated, which are applicable to both the singular and plural thereof.

- 1.1 Addendum - A written or graphic instrument that is issued prior to the opening of bids and that clarifies, corrects, or changes the Bidding Documents.
- 1.2 Agreement or Contract - The written agreement between the Owner and the Contractor covering the Work to be performed and furnished; these Supplementary Conditions and other Contract Documents are attached to the Agreement/Contract and made a part thereof as provided therein.
- 1.3 Bid - The offer or proposal of a bidder submitted on the prescribed form and setting forth the price(s) for the Work to be performed and furnished.
- 1.4 Bidder - Any person, firm, or corporation that submits a bid directly to the Owner.
- 1.5 Bidding Documents - The Advertisement for Bids or the Invitation to Bid, the Instructions to Bidders or the Information for Bidders, the Bid Form, the proposed Contract Documents, and all addenda.
- 1.6 Bond - An instrument of security.
- 1.7 Change Order - A document that is recommended by the Engineer and signed by the Contractor and the Owner; that authorizes an addition, deletion, or revision in the Work or an adjustment in the Contract Price or the Contract Time; and that is issued on or after the Effective Date of the Agreement/Contract.
- 1.8 Contract Documents - The Agreement/Contract; the Contractor's Bid when attached as an exhibit to the Agreement/Contract; the Performance and Payment Bond(s); the General Conditions; the Supplementary Conditions (including these Supplementary Conditions); the Specifications (written technical descriptions of material, equipment, construction systems, standards, and workmanship as applied to the Work and certain administrative details applicable thereto); the Drawings (drawings that show the character and scope of the Work to be performed and furnished); all addenda that pertain to the Contract Documents; and all change orders.
- 1.9 Contract Time - The number of days or the date stated in the Contract Documents for completion of the Work.
- 1.10 Contractor - The person, firm, or corporation with whom or which the Owner enters into the Agreement/Contract.
- 1.11 Effective Date of the Agreement/Contract - The date indicated in the Agreement/Contract on which the Agreement/Contract becomes effective, or if no such date is indicated in the Agreement/Contract, the date on which the Agreement/Contract is signed and delivered by the last of the two parties to sign and deliver the Agreement/Contract.
- 1.12 Engineer - The person, firm, or corporation named as such in the Contract Documents.
- 1.13 Minority Business Enterprise (MBE) - A historically Black college or university or a business that is (a) certified as socially and economically disadvantaged by the Small Business Administration, (b) certified as an MBE by a state or federal agency, or (c) an independent business concern which is at least 51-percent owned and controlled by minority group members. (A minority group member is an individual who is a citizen of the United States and one of the following: [i] Black American; [ii] Hispanic American [with origins from Puerto Rico, Mexico, Cuba, or South or Central America]; [iii] Native American [American Indian, Eskimo, Aleut, or native Hawaiian]; or [iv] Asian-Pacific American

[with origins from Japan, China, the Philippines, Vietnam, Korea, Samoa, Guam, the U.S. Trust Territories of the Pacific, Northern Marianas, Laos, Cambodia, Taiwan, or the Indian Subcontinent].)

1.14 Notice to Proceed - The written notice given by the Owner to the Contractor fixing the date on which the Contract Time will commence to run and on which the Contractor shall start to perform its obligations under the Contract Documents.

1.15 Owner - The local government (municipality, county, district, or authority; or any agency thereof; or a combination of two or more of the foregoing acting jointly) with which the Florida Department of Environmental Protection (FDEP) may execute, or has executed, a State Revolving Fund loan agreement and for which the Work is to be provided.

1.16 Project - The total construction or facilities described in a State Revolving Fund loan agreement between the FDEP and the Owner, of which the Work to be provided under the Contract Documents may be the whole or a part.

1.17 Sponsor - The recipient of the State Revolving Fund loan agreement that provides funds for the project.

1.18 Subcontract - A direct contract between a subcontractor and the Contractor, or any other subcontractor at any tier, for the furnishing of goods (material and equipment) or the performance of services (including construction) necessary to complete the Work.

1.19 Subcontractor - A person, firm, or corporation having a direct contract with the Contractor, or any other subcontractor at any tier, for the furnishing of goods (material and equipment) or the performance of services (including construction) necessary to complete the Work.

1.20 Successful Bidder - The lowest responsive, responsible bidder to whom or which the Owner intends to award the Agreement/Contract.

1.21 Women's Business Enterprise (WBE) - A business that is (a) certified as a WBE by a state or federal agency or (b) an independent business concern which is at least 51-percent owned and controlled/operated by women. (Determination of whether a business is at least 51-percent owned by women shall be made without regard to community property laws [e.g., an otherwise qualified WBE that is 51-percent owned by a married woman in a community property state will not be disqualified because the married woman's husband has a 50-percent interest in the married woman's share of the business; similarly, a business that is 51-percent owned by a married man and 49-percent owned by women will not become a qualified WBE by virtue of the married man's wife having a 50-percent interest in the married man's share of the business].)

1.22 Work - The entire completed construction or the various separately identifiable parts thereof required to be performed and furnished under the Contract Documents; Work is the result of performing services, furnishing labor, furnishing material and equipment, and incorporating material and equipment into the construction as required by the Contract Documents.

ARTICLE 2 - PRIVACY OF AGREEMENT/CONTRACT

2.1. The Owner expects to finance this Agreement/Contract with assistance from the FDEP, which administers a State Revolving Fund loan program supported in part with funds directly made available by grants from the United States Environmental Protection Agency (USEPA). Neither the State of Florida nor the United States (nor any of their departments, agencies, or employees) will be a party to this Agreement/Contract or any lower-tier subcontract.

ARTICLE 3 - PROCUREMENT REQUIREMENTS

3.1. This Agreement/Contract and the Owner's solicitation and award of this Agreement/Contract are subject to requirements contained in Chapter 62-503 (Revolving Loan Program) and/or Chapter 62-552, Florida Administrative Code as applicable.

ARTICLE 4 - RESOLUTION OF PROTESTS AND CLAIMS/DISPUTES

Resolution of Protests Concerning the Owner's Solicitation and/or Award of this Agreement/Contract:

4.1. Protests concerning the Owner's solicitation and/or award of this Agreement/Contract must be filed in writing with the Owner to be considered.

4.2. All timely written protests concerning the Owner's solicitation and/or award of this Agreement/Contract are to be resolved in accordance with the Owner's dispute resolution process. A copy of the ordinance(s), resolution(s), or written policy (policies) that set forth the Owner's dispute resolution process is included elsewhere in the Bidding Documents or is to be made available by the Owner upon request.

4.3. Neither the (FDEP) nor the USEPA will become a party to, or have any role in resolving, protests concerning the Owner's solicitation and/or award of this Agreement/Contract. Protest decisions made by the Owner cannot be appealed to the FDEP or the USEPA.

Resolution of Claims and Disputes Between the Owner and the Contractor:

4.4. Unless otherwise provided in the Contract Documents, all claims and disputes between the Owner and the Contractor arising out of, or relating to, the Contract Documents or the breach thereof are to be decided by arbitration (if the Owner and the Contractor mutually agree) or in a court of competent jurisdiction within the State of Florida.

4.5. Neither the FDEP nor the USEPA will become a party to, or have any role in resolving, claims and disputes between the Owner and the Contractor.

ARTICLE 5 - CHANGES TO THE BIDDING AND CONTRACT DOCUMENTS

5.1. All changes to the Bidding Documents made subsequent to the FDEP's acceptance of the Bidding Documents and prior to the opening of bids are to be documented via addendum (addenda) to the Bidding Documents; all changes to the Contract Documents made after the opening of bids are to be documented by change order(s) to the Contract Documents. The Owner shall submit all addenda and change orders to the FDEP.

ARTICLE 6 - BONDS AND INSURANCE

Bid Guarantees:

6.1. Each bidder's bid is to be accompanied by a bid guarantee made payable to the Owner in an amount at least equal to five percent of the bidder's maximum bid price and in the form of a certified check or bid bond.

Performance and Payment Bond(s):

6.2. The Contractor shall furnish a combined performance and payment bond in an amount at least equal to 100 percent of the Contract Price (or, if required elsewhere in the Contract Documents, the Contractor shall furnish separate performance and payment bonds, each in an amount at least equal to 100 percent of the Contract Price) as security for the faithful performance and payment of all the Contractor's obligations under the Contract Documents. This(these) bond(s) are to be delivered to the Owner by the Contractor along with the executed Agreement/Contract. The Owner shall forward a copy of this (these) bond(s) to the FDEP.

Insurance:

6.3. The Owner and/or the Contractor (as required elsewhere in the Contract Documents) shall purchase and maintain, during the period of construction, such liability insurance as is appropriate for the Work being performed and furnished, and as will provide protection from claims that may arise out of, or result from, the Contractor's performance and furnishing of the Work (whether the Work is to be performed or furnished by the Contractor or any subcontractor at the Work site) and the Contractor's other obligations under the Contract Documents. This insurance is to include workers' compensation insurance, comprehensive general liability insurance, comprehensive automobile liability insurance, and contractual liability insurance applicable to the Contractor's indemnification obligations and is to be written for not less than the limits of liability and coverages determined by the Owner or required by law, whichever is greater.

6.4. The Owner and/or the Contractor (as required elsewhere in the Contract Documents) shall purchase and maintain, during the period of construction, property insurance upon the Work at the Work site in an amount equal to the full replacement cost of the Work or the full insurable value of the Work. This insurance is to include the interests of the Owner, the Contractor, and all subcontractors at the Work site (all of whom are to be listed as insured or additional insured parties); is to insure against the perils of fire and extended coverage; and is to include "all-risk" insurance for physical loss or damage due to theft, vandalism and malicious mischief, collapse, water damage, and/or all other risks against which coverage is obtainable.

6.5. Before any Work at the Work site is started, the Contractor shall deliver to the Owner certificates of insurance that the Contractor is required to purchase and maintain in accordance with Paragraphs 6.3 and 6.4 of this Article and other provisions of the Contract Documents, and the Owner shall deliver to the Contractor certificates of insurance that the Owner is required to purchase and maintain in accordance with Paragraphs 6.3 and 6.4 of this Article and other provisions of the Contract Documents.

ARTICLE 7 - AWARD OF AGREEMENT/CONTRACT

7.1. If this Agreement/Contract is awarded, it is to be awarded to the lowest responsive, responsible bidder. A fixed price (lump sum or unit price or both) agreement/contract is to be used. A clear explanation of the method of evaluating bids and the basis for awarding this Agreement/Contract are included elsewhere in the Bidding Documents. All bids may be rejected when in the best interest of the Owner. After the contract has been awarded, the Owner shall give the Contractor a notice to proceed fixing the date on which the Contract Time will commence to run. The Owner shall forward a copy of this notice to proceed to the FDEP.

ARTICLE 8 - ITEMIZED CONSTRUCTION COST BREAKDOWN; CONSTRUCTION AND PAYMENT SCHEDULES

8.1. The Contractor shall submit to the Owner, within ten calendar days after the Effective Date of this Agreement/Contract, an itemized construction cost breakdown and construction and payment schedules.

8.1.1. The itemized construction cost breakdown, or schedule of values, is to include quantities and prices of items aggregating the Contract Price and is to subdivide the Work into component parts in sufficient detail to serve as the basis for progress payments during construction. Such prices are to include an appropriate amount of overhead and profit applicable to each item of Work.

8.1.2. The construction, or progress, schedule is to indicate the Contractor's estimated starting and completion dates for the various stages of the Work and is to show both the projected cost of Work completed and the projected percentage of Work completed versus Contract Time.

8.1.3. The payment schedule is to show the Contractor's projected payments cumulatively by month.

ARTICLE 9 - FDEP/USEPA ACCESS TO RECORDS AND PROJECT SITE

9.1. Authorized representatives of the Owner, the FDEP, and the USEPA shall have access to, for the purpose of inspection, the Work site(s), any books, documents, papers, and records of the Contractor that are pertinent to this Agreement/Contract at any reasonable time. The Contractor shall retain all books, documents, papers, and records pertinent to this Agreement/Contract for a period of five years after receiving and accepting final payment under this Agreement/Contract.

NOTE: ARTICLE 10 ONLY APPLIES TO FEDERAL CAP GRANT PROJECTS

ARTICLE 10 - DISADVANTAGED BUSINESS ENTERPRISES

10.1 A goal of five percent of the Contract Price is established for Minority Business Enterprise (MBE) participation in the Work, and a goal of five percent of the Contract Price is established for Women's Business Enterprise (WBE) participation in the Work. If bidders or prospective contractors (including the Contractor) intend to let any lower-tier goods

or services (including construction) subcontracts for any portion of the Work, they shall physically include these percentage goals for MBE and WBE participation in all solicitations for subcontracts and shall take good faith efforts to assure that MBEs and WBEs are utilized, when possible, as sources of goods and services. Good faith efforts are to include the following:

10.1.1. Require Disadvantaged Business Enterprises (DBEs) are made aware of contracting opportunities to the fullest extent practicable through outreach and recruitment activities. For Indian Tribal, State and Local and Government recipients, this will include placing DBEs on solicitation lists and soliciting them whenever they are potential sources.

10.1.2. Make information on forthcoming opportunities available to DBEs and arrange time frames for contracts and establish delivery schedules, where the requirements permit, in a way that encourages and facilitates participation by DBEs in the competitive process. This includes, whenever possible, posting solicitations for bids or proposals for a minimum of 30 calendar days before the bid or proposal closing date.

10.1.3. Consider in the contracting process whether firms competing for large contracts could subcontract with DBEs. For Indian Tribal, State and local Government recipients, this will include dividing total requirements when economically feasible into smaller tasks or quantities to permit maximum participation by DBEs in the competitive process.

10.1.4. Encourage contracting with a consortium of DBEs when a contract is too large for one of these firms to handle individually.

10.1.5. Use the services and assistance of the Small Business Administration and the Minority Business Development Agency of the Department of Commerce.

10.1.6. If the prime contractor awards subcontracts, require the prime contractor to take the steps in paragraphs 10.1.1 through 10.1.5 of this section.

10.2. Within ten calendar days after being notified of being the apparent Successful Bidder, the apparent Successful Bidder shall submit to the Owner documentation of the affirmative steps it has taken to utilize Minority and Women's Business Enterprises (MBEs and WBEs) in the Work and documentation of its intended use of MBEs and WBEs in the Work. The Owner shall keep this documentation on file and shall forward to the FDEP a copy of the apparent Successful Bidder's documentation concerning its intended use of MBEs and WBEs in the Work.

ARTICLE 11 - DEBARMENT AND SUSPENSION (EXECUTIVE ORDER 12549)

Certification Regarding Debarment, Suspension, Ineligibility and Voluntary Exclusion - Lower Tier Covered Transactions

11.1. The bidder certifies, by submission of this proposal, that neither the bidder nor its principals, nor the bidder's subcontractors nor their principals, are presently debarred, suspended, proposed for debarment, declared ineligible, or voluntarily excluded from participation in this transaction by any federal department or agency.

11.2. Where the bidder is unable to certify to any of the statements in this certification, such prospective participant shall attach an explanation to this proposal.

11.3. The bidder also certifies that it and its principals and the bidder's subcontractors and their principals:

11.3.1. Have not within a three-year period preceding this proposal been convicted of or had a civil judgment rendered against them for commission of fraud or a criminal offense in connection with obtaining, attempting to obtain, or performing a public (federal, state or local) transaction or contract under a public transaction; violation of federal or state anti-trust statutes or commission of embezzlement, theft, forgery, bribery, falsification or destruction of records, making false statements, or receiving stolen property;

11.3.2. Are not presently indicted for or otherwise criminally or civilly charged by a governmental entity (federal, state or local) with commission of any of the offenses enumerated in paragraph 11.3.1 of this certification; and

11.3.3. Have not within a three-year period preceding this proposal had one or more public transactions (federal, state or local) terminated for cause or default. Where the bidder is unable to certify to any of the above, such owner shall attach an explanation to this proposal.

11.3.4. The certification in this clause is a material representation of fact upon which reliance was placed when this transaction was entered into. If it is later determined that the prospective lower tier participant knowingly rendered an erroneous certification, in addition to other remedies available to the federal government, the department or agency with which this transaction originated may pursue available remedies, including suspension and/or debarment.

11.3.5. The bidder shall incorporate the foregoing requirements 11.1 through 11.3 in all subcontracts.

ARTICLE 12 - EQUAL EMPLOYMENT OPPORTUNITY (EXECUTIVE ORDER 11246)

12.1. Notice of Requirement for Affirmative Action to Ensure Equal Employment Opportunity (Executive Order 11246). (Applicable to contracts/subcontracts exceeding \$10,000)

12.1.1. The Offeror's or Bidder's attention is called to the "Equal Opportunity Clause" and the "Standard Federal Equal Employment Specifications" set forth herein.

12.1.2. The goals and timetables for minority and female participation, expressed in percentage terms for the Contractor's aggregate workforce in each trade on all construction work in Florida, are as follows:

Goal for female participation: 6.9 percent statewide

Goal for minority participation: (See Appendix B at FDEP-14 for goals for each county)

These goals are applicable to all the Contractor's construction work (whether or not it is federal or federally assisted) performed in the covered area. If the contractor performs construction work in a geographical area located outside of the covered area, it shall apply the goals established for such geographical area where the work is actually performed. With regard to this second area, the contractor also is subject to the goals for both its federally involved and non-federally involved construction.

The Contractor's compliance with the Executive Order and the regulations in 41 CFR Part 60-4 shall be based on its implementation of the Equal Opportunity Clause, specific affirmative action obligations required by the specifications set forth in 41 CFR 60-4.3(a), and its efforts to meet the goals. The hours of minority and female employment and training must be substantially uniform throughout the length of the contract, and in each trade, and the contractor shall make a good faith effort to employ minorities and women evenly on each of its projects. The transfer of minority or female employees or trainees from Contractor to Contractor or from project to project for the sole purpose of meeting the Contractor's goals shall be a violation of the contract, the Executive Order and the regulations in 41 CFR Part 60-4. Compliance with the goals will be measured against the total work hours performed.

12.1.3. The Contractor shall provide written notification to the Director of the Office of Federal Contract Compliance Programs within 10 working days of award of any construction subcontract in excess of \$10,000 at any tier for construction work under the contract resulting from this solicitation. The notification shall list the name, address and telephone number of the subcontractor; employer identification number of the subcontractor; estimated dollar amount of the subcontract; estimated starting and completion dates of the subcontract; and the geographical area in which the subcontract is to be performed.

12.1.4. As used in this Notice, and in the contract resulting from this solicitation, the "covered area" is the State of Florida.

12.1.5. Contractors shall incorporate the foregoing requirements in all subcontracts.

12.2. Equal Opportunity Clause (Applicable to contracts/subcontracts exceeding \$10,000)

During the performance of this contract, the contractor agrees as follows:

12.2.1. The Contractor shall not discriminate against any employee or applicant for employment because of race, color, religion, sex, or national origin. The Contractor shall take affirmative action to ensure that applicants for employment are employed, and that employees are treated during employment, without regard to their race, color, religion, sex, or national origin. Such action shall include, but not be limited to, the following: employment, upgrading, demotion, or transfer; recruitment or recruitment advertising; layoff or termination; rates of pay or other forms of compensation; and selection for training, including apprenticeship.

12.2.2. The Contractor shall post in conspicuous places, available to employees and applicants for employment, notices setting forth the provisions of this nondiscrimination clause. The notice can be obtained online at http://www.eeoc.gov/employers/upload/eeoc_self_print_poster.pdf. The Contractor shall state that all qualified applicants be considered without regard to race, color, religion, sex or national origin.

12.2.3. The contractor will, in all solicitations or advertisements for employees placed by or on behalf of the contractor, state that all qualified applicants will receive considerations for employment without regard to race, color, religion, sex, or national origin.

12.2.4. The contractor will send to each labor union or representative of workers with which he has a collective bargaining agreement or other contract or understanding, a notice to be provided advising the said labor union or workers' representatives of the contractor's commitments under this section, and shall post copies of the notice in conspicuous places available to employees and applicants for employment.

12.2.5. The contractor will comply with all provisions of Executive Order 11246 of September 24, 1965, and of the rules, regulations, and relevant orders of the Secretary of Labor.

12.2.6. The contractor will furnish all information and reports required by Executive Order 11246 of September 24, 1965, and by rules, regulations, and orders of the Secretary of Labor, or pursuant thereto, and will permit access to his books, records, and accounts by the administering agency and the Secretary of Labor for purposes of investigation to ascertain compliance with such rules, regulations, and orders.

12.2.7. In the event of the contractor's noncompliance with the nondiscrimination clauses of this contract or with any of the said rules, regulations, or orders, this contract may be canceled, terminated, or suspended in whole or in part and the contractor may be declared ineligible for further Government contracts or federally assisted construction contracts in accordance with procedures authorized in Executive Order 11246 of September 24, 1965, and such other sanctions may be imposed and remedies invoked as provided in Executive Order 11246 of September 24, 1965, or by rule, regulation, or order of the Secretary of Labor, or as otherwise provided by law.

12.2.8. The contractor will include the portion of the sentence immediately preceding paragraph (1) and the provisions of paragraphs 12.2.1 through 12.2.8 in every subcontract or purchase order unless exempted by rules, regulations, or orders of the Secretary of Labor issued pursuant to section 204 of Executive Order 11246 of September 24, 1965, so that such provisions will be binding upon each subcontractor or vendor. The contractor will take such action with respect to any subcontract or purchase order as the administering agency may direct as a means of enforcing such provisions, including sanctions for noncompliance: Provided, however, that in the event a contractor becomes involved in, or is threatened with, litigation with a subcontractor or vendor as a result of such direction by the administering agency, the contractor may request the United States to enter into such litigation to protect the interests of the United States.

12.3. The Standard Federal Equal Employment Opportunity Construction Contract Specifications (Executive Order 11246)

12.3.1. As used in these specifications:

a. "Covered area" means the geographical area described in the solicitation from which this contract resulted;

b. "Director" means Director, Office of Federal Contract Compliance Programs, United States Department of Labor, or any person to whom the Director delegates authority;

c. "Employer identification number" means the Federal Social Security number used on the Employer's Quarterly Federal Tax Return, U.S. Treasury Department Form 941.

d. "Minority" includes:

- (i) Black (all persons having origins in any of the Black African racial groups not of Hispanic origin);
- (ii) Hispanic (all persons of Mexican, Puerto Rican, Cuban, Central or South American or other Spanish Culture or origin, regardless of race);
- (iii) Asian and Pacific Islander (all persons having origins in any of the original peoples of the Far East, Southeast Asia, the Indian Subcontinent, or the Pacific Islands); and

(iv) American Indian or Alaskan Native (all persons having origins in any of the original peoples of North America and maintaining identifiable tribal affiliations through membership and participation or community identification).

12.3.2. Whenever the Contractor, or any Subcontractor at any tier, subcontracts a portion of the work involving any construction trade, it shall physically include in each subcontract in excess of \$10,000 the provisions of these specifications and the Notice which contains the applicable goals for minority and female participation and which is set forth in the solicitations from which this contract resulted.

12.3.3. If the Contractor is participating (pursuant to 41 CFR 60-4.5) in a Hometown Plan approved by the U.S. Department of Labor in the covered area either individually or through an association, its affirmative action obligations on all work in the Plan area (including goals and timetables) shall be in accordance with that Plan for those trades which have unions participating in the Plan. Contractors must be able to demonstrate their participation in and compliance with the provisions of any such Hometown Plan. Each Contractor or Subcontractor participating in an approved Plan is individually required to comply with its obligations under the EEO clause, and to make a good faith effort to achieve each goal under the Plan in each trade in which it has employees. The overall good faith performance by other Contractors or Subcontractors toward a goal in an approved Plan does not excuse any covered Contractor's or Subcontractor's failure to take good faith efforts to achieve the Plan goals and timetables.

12.3.4. The Contractor shall implement the specific affirmative action standards provided in paragraphs 7a through p of these specifications. The goals set forth in the solicitation from which this contract resulted are expressed as percentages of the total hours of employment and training of minority and female utilization the Contractor should reasonably be able to achieve in each construction trade in which it has employees in the covered area. Covered construction Contractors performing construction work in geographical areas where they do not have a federal or federally assisted construction contract shall apply the minority and female goals established for the geographical area where the work is being performed. Goals are published periodically in the FEDERAL REGISTER in notice form, and such notices may be obtained from any Office of Federal Contract Compliance Programs office or from federal procurement contracting officers. The Contractor is expected to make substantially uniform progress in meeting its goals in each craft during the period specified.

12.3.5. Neither the provisions of any collective bargaining agreement, nor the failure by a union with whom the Contractor has a collective bargaining agreement, to refer either minorities or women shall excuse the Contractor's obligations under these specifications, Executive Order 11246, or the regulations promulgated pursuant thereto.

12.3.6. In order for the nonworking training hours of apprentices and trainees to be counted in meeting the goals, such apprentices and trainees must be employed by the Contractor during the training period, and the Contractor must have made a commitment to employ the apprentices and trainees at the completion of their training, subject to the availability of employment opportunities. Trainees must be trained pursuant to training programs approved by the U.S. Department of Labor.

12.3.7. The Contractor shall take specific affirmative actions to ensure equal employment opportunity. The evaluation of the Contractor's compliance with these specifications shall be based upon its effort to achieve maximum results from its actions. The Contractor shall document these efforts fully, and shall implement affirmative action steps at least as extensive as the following:

- a. Ensure and maintain a working environment free of harassment, intimidation, and coercion at all sites, and in all facilities at which the Contractor's employees are assigned to work. The Contractor, where possible, will assign two or more women to each construction project. The Contractor shall specifically ensure that all foremen, superintendents, and other on-site supervisory personnel are aware of and carry out the Contractor's obligation to maintain such a working environment, with specific attention to minority or female individuals working at such sites or in such facilities.
- b. Establish and maintain a current list of minority and female recruitment sources, provide written notification to minority and female recruitment sources and to community organizations when the Contractor or its unions have employment opportunities available, and maintain a record of the organizations' responses.

- c. Maintain a current file of the names, addresses and telephone numbers of each minority and female off-the-street applicant and minority or female referral from a union, a recruitment source or community organization and of what action was taken with respect to each such individual. If such individual was sent to the union hiring hall for referral and was not referred back to the Contractor by the union or, if referred, not employed by the Contractor, this shall be documented in the file with the reason therefore, along with whatever additional actions the Contractor may have taken.
- d. Provide immediate written notification to the Director when the union or unions with which the Contractor has a collective bargaining agreement has not referred to the Contractor a minority person or woman sent by the Contractor, or when the Contractor has other information that the union referral process has impeded the Contractor's efforts to meet its obligations.
- e. Develop on-the-job training opportunities and/or participate in training programs for the area which expressly include minorities and women, including upgrading programs and apprenticeship and trainee programs relevant to the Contractor's employment needs, especially those programs funded or approved by the Department of Labor. The Contractor shall provide notice of these programs to the sources compiled under 12.3.7b above.
- f. Disseminate the Contractor's EEO policy by providing notice of the policy to unions and training programs and requesting their cooperation in assisting the Contractor in meeting its EEO obligations; by including it in any policy manual and collective bargaining agreement; by publicizing it in the company newspaper, annual report, etc.; by specific review of the policy with all management personnel and with all minority and female employees at least once a year; and by posting the company EEO policy on bulletin boards accessible to all employees at each location where construction work is performed.
- g. Review, at least annually, the company's EEO policy and affirmative action obligations under these specifications with all employees having any responsibility for hiring, assignment, layoff, termination or other employment decisions including specific review of these items with onsite supervisory personnel such as Superintendents, General Foremen, etc., prior to the initiation of construction work at any job site. A written record shall be made and maintained identifying the time and place of these meetings, persons attending, subject matter discussed, and disposition of the subject matter.
- h. Disseminate the Contractor's EEO policy externally by including it in any advertising in the news media, specifically including minority and female news media, and providing written notification to and discussing the Contractor's EEO policy with other Contractors and Subcontractors with whom the Contractor does or anticipates doing business.
- i. Direct its recruitment efforts, both oral and written, to minority, female and community organizations, to schools with minority and female students and to minority and female recruitment and training organizations serving the Contractor's recruitment area and employment needs. Not later than one month prior to the date for the acceptance of applications for apprenticeship or other training by any recruitment source, the Contractor shall send written notification to organizations such as the above, describing the openings, screening procedures, and tests to be used in the selection process.
- j. Encourage present minority and female employees to recruit other minority persons and women and, where reasonable, provide after school, summer and vacation employment to minority and female youth both on the site and in other areas of a Contractor's work force.
- k. Validate all tests and other selection requirements where there is an obligation to do so under 41 CFR Part 60-3.
- l. Conduct, at least annually, an inventory and evaluation at least of all minority and female personnel for promotional opportunities and encourage these employees to seek or to prepare for, through appropriate training, etc., such opportunities.
- m. Ensure that seniority practices, job classifications, work assignments and other personnel practices, do not have a discriminatory effect by continually monitoring all personnel and employment related activities to ensure that the EEO policy and the Contractor's obligations under these specifications are being carried out.

n. Ensure that all facilities and company activities are nonsegregated except that separate or single-user toilet and necessary changing facilities shall be provided to assure privacy between the sexes.

o. Document and maintain a record of all solicitations of offers for subcontracts from minority and female construction contractors and suppliers, including circulation of solicitations to minority and female contractor associations and other business associations.

p. Conduct a review, at least annually, of all supervisors' adherence to and performance under the Contractor's EEO policies and affirmative action obligations.

12.3.8. Contractors are encouraged to participate in voluntary associations which assist in fulfilling one or more of their affirmative action obligations (12.3.7a through 12.3.7p). The efforts of a contractor association, joint contractor-union, contractor-community, or other similar group of which the contractor is a member and participant, may be asserted as fulfilling any one or more of its obligations under 7a through p of these specifications provided that the contractor actively participates in the group, makes every effort to assure that the group has a positive impact on the employment of minorities and women in the industry, ensures that the concrete benefits of the program are reflected in the Contractor's minority and female workforce participation, makes a good faith effort to meet its individual goals and timetables, and can provide access to documentation which demonstrates the effectiveness of actions taken on behalf of the Contractor. The obligation to comply, however, is the Contractor's and failure of such a group to fulfill an obligation shall not be a defense for the Contractor's noncompliance.

12.3.9. A single goal for minorities and a separate single goal for women have been established. The Contractor, however, is required to provide equal employment opportunity and to take affirmative action for all minority groups, both male and female, and all women, both minority and non-minority. Consequently, the Contractor may be in violation of the Executive Order if a particular group is employed in a substantially disparate manner (for example, even though the Contractor has achieved its goals for women generally, the Contractor may be in violation of the Executive Order if a specific minority group of women is underutilized).

12.3.10. The Contractor shall not use the goals and timetables or affirmative action standards to discriminate against any person because of race, color, religion, sex, or national origin.

12.3.11. The Contractor shall not enter into any Subcontract with any person or firm debarred from Government contracts pursuant to Executive Order 11246.

12.3.12. The Contractor shall carry out such sanctions and penalties for violation of these specifications and of the Equal Opportunity Clause, including suspension, termination and cancellation of existing subcontracts as may be imposed or ordered pursuant to Executive Order 11246, as amended, and its implementing regulations, by the Office of Federal Contract Compliance Programs. Any Contractor who fails to carry out such sanctions and penalties shall be in violation of these specifications and Executive Order 11246, as amended.

12.3.13. The Contractor, in fulfilling its obligation under these specifications, shall implement specific affirmative action steps, at least as extensive as those standards prescribed in paragraph 7 of these specifications, so as to achieve maximum results from its efforts to ensure equal employment opportunity. If the Contractor fails to comply with the requirements of the Executive Order, the implementing regulations, or these specifications, the Director shall proceed in accordance with 41 CFR 60-4.8.

12.3.14. The Contractor shall designate a responsible official to monitor all employment related activity to ensure that the company EEO policy is being carried out, to submit reports relating to the provisions hereof as may be required by the Government and to keep records. Records shall at least include for each employee the name, address, telephone numbers, construction trade, union affiliation if any, employee identification number when assigned, social security number, race, sex, status (e.g., mechanic, apprentice trainee, helper, or laborer), dates of changes in status, hours worked per week in the indicated trade, rate of pay, and locations at which the work was performed. Records shall be maintained in an easily understandable and retrievable form; however, to the degree that existing records satisfy this requirement, contractors shall not be required to maintain separate records.

12.3.15. Nothing herein provided shall be construed as a limitation upon the application of other laws which establish different standards of compliance or upon the application of requirements for the hiring of local or other area residents (e.g., those under the Public Works Employment Act of 1977 and the Community Development Block Grant Program).

12.4. Pursuant to 41 CFR 60-1.7, if the price of this bid exceeds \$10,000, the bidder, by signing and submitting this proposal, certifies the following:

12.4.1. Affirmative action programs pursuant to 41 CFR 60-2 have been developed and are on file;

12.4.2. Documentation of a previous contract or subcontract subject to the equal opportunity clause is available;

12.4.3. All reports due under the applicable filing requirements have been filed with the Joint Reporting Committee, the Deputy Assistant Secretary or the Equal Employment Opportunity Commission; and

12.4.4. Each prospective construction subcontractor that may be awarded a lower-tier construction subcontract with a price exceeding \$10,000 shall meet the above requirements 12.4.1 through 12.4.3.

12.5. Pursuant to 41 CFR 60-1.8, if the price of this bid exceeds \$10,000, the bidder, by signing and submitting this proposal, certifies the following:

12.5.1. That he/she does not maintain or provide for his/her employees any segregated facility at any of his/her establishments;

12.5.2. That he/she does not permit employees to perform their services at any location, under his/her control, where segregated facilities are maintained;

12.5.3. That he/she will not maintain or provide for employees any segregated facilities at any of his/her establishments;

12.5.4. That he/she will not permit employees to perform their services at any location under his/her control where segregated facilities are maintained;

12.5.5. That a breach of this certification is violation of the Equal Opportunity Clause of this contract; and

12.5.6. That he/she will obtain identical certifications from proposed Subcontractors prior to the award of Subcontracts exceeding \$10,000 which are not exempt from the provisions of the Equal Opportunity clause, and that he will retain such certifications in his/her files.

As used in this certification, the term "segregated facilities" means any waiting rooms, work eating areas, time clocks, locker rooms, and other storage or dressing areas, transportation and housing facilities provided for employees which are in fact segregated on the basis of race, color, religion, or otherwise.

12.6. If the price of this Agreement/Contract exceeds \$10,000, the Owner shall give written notice to the Director of the Office of Federal Contract Compliance Programs within ten working days of award of this Agreement/Contract. The notice is to include the name, address, and telephone number of the Contractor; the employer identification number of the Contractor; the dollar amount of this Agreement/Contract; the estimated starting and completion dates of this Agreement/Contract; the number of this Agreement/Contract; and the geographical area in which the Work is to be performed.

12.7. If the price of this Agreement/Contract equals or exceeds \$50,000 and if the Contractor has 50 or more employees, the Contractor shall electronically file Standard Form 100 (EEO-1) online at <https://egov.eeoc.gov/eo1/eo1.jsp> within 30 calendar days after the award of this Agreement/Contract, unless the Contractor has submitted such a report within 12 months preceding the date of award of this Agreement/Contract. In addition, the Contractor shall ensure that each construction subcontractor having 50 or more employees and a lower-tier construction subcontract with a price equaling or exceeding \$50,000 also electronically files this form within 30 calendar days after the award to it of the lower-tier construction subcontract, unless the construction subcontractor has submitted such a report within 12 months preceding the date of award of the lower-tier construction subcontract.

ARTICLE 13 - IMMIGRATION REFORM AND CONTROL ACT OF 1986 (STATE OF FLORIDA EXECUTIVE ORDER 11-116)

The Immigration Reform and Control Act of 1986 prohibits employers from knowingly hiring illegal workers. The Contractor shall only employ individuals who may legally work in the United States – either U.S. citizens or foreign citizens who are authorized to work in the U.S. The Contractor shall use the U.S. Department of Homeland Security's E-Verify Employment Eligibility Verification system (<http://www.uscis.gov/portal/site/uscis>) to verify the employment eligibility of:

- all new employees, during the term of this Agreement, to perform employment duties within Florida; and,
- all new employees (including subcontractors and subrecipients) assigned by the Contractor to perform work pursuant to this Agreement.

The Contractor shall include this provision in all subcontracts/subgrants it enters into for the performance of work under this Agreement.

ARTICLE 14 – ENVIRONMENTAL COMPLIANCE

The Contractor, and all subcontractors at any tier, shall comply with all applicable standards, orders, or requirements issued under Section 306 of the Clean Air Act (42 U.S.C. 1857[h]), Section 508 of the Clean Water Act (33 U.S.C. 1368), Executive Order 11738 (Administration of the Clean Air Act and the Federal Water Pollution Control Act with Respect to Federal Contracts, Grants, or Loans), and 40 CFR Part 15.

ARTICLE 15 – FEDERAL LABOR STANDARDS PROVISION

Contracts being constructed with assistance from the State Revolving Fund Program are currently required to comply with the Federal Labor Standards Provisions as provided in Appendix C. Signing Appendix A certifies compliance with these provisions.

ARTICLE 16 – AMERICAN IRON AND STEEL PROVISION

Contracts being constructed with assistance from the State Revolving Fund Program are currently required to comply with The American Iron and Steel Provision as provided in Appendix D. Signing Appendix A certifies compliance with these provisions.

ARTICLE 17 - PROHIBITED LOCAL GOVERNMENT CONSTRUCTION PREFERENCES

- A. Pursuant to Section 255.0991, F.S., for a competitive solicitation for construction services in which 50 percent or more of the cost will be paid from state-appropriated funds which have been appropriated at the time of the competitive solicitation, a state, college, county, municipality, school district, or other political subdivision of the state may not use a local ordinance or regulation that provides a preference based upon:
1. The contractor's maintaining an office or place of business within a particular local jurisdiction;
 2. The contractor's hiring employees or subcontractors from within a particular local jurisdiction; or
 3. The contractor's prior payment of local taxes, assessments, or duties within a particular local jurisdiction.
- B. For any competitive solicitation that meets the criteria in Paragraph A., a state college, county, municipality, school district, or other political subdivision of the state shall disclose in the solicitation document that any applicable local ordinance or regulation does not include any preference that is prohibited by Paragraph A.

**APPENDIX A TO THE FLORIDA DEPARTMENT OF ENVIRONMENTAL PROTECTION
SUPPLEMENTARY CONDITIONS**

**CERTIFICATION OF COMPLIANCE WITH THE FLORIDA DEPARTMENT OF
ENVIRONMENTAL PROTECTION SUPPLEMENTARY CONDITIONS**

This certification relates to a construction contract proposed by _____
(insert the name of the Owner)

which expects to finance the proposed construction contract with assistance from the Florida Department of Environmental Protection (which administers a State Revolving Fund loan program supported in part with funds directly made available by grants from the United States Environmental Protection Agency). I am the undersigned prospective construction contractor or subcontractor.

I certify that I have read the Florida Department of Environmental Supplementary Conditions and agree to incorporate the following articles into the bid and/or contract:

- ARTICLE 11 DEBARMENT AND SUSPENSION - EXECUTIVE ORDER 12549
- ARTICLE 12 EQUAL EMPLOYMENT OPPORTUNITY - EXECUTIVE ORDER 11246
- ARTICLE 13 IMMIGRATION REFORM AND CONTROL ACT OF 1986 AND STATE OF
FLORIDA EXECUTIVE ORDER 11-116
- ARTICLE 14 ENVIRONMENTAL COMPLIANCE
- ARTICLE 15 FEDERAL LABOR STANDARDS PROVISION
- ARTICLE 16 AMERICAN IRON AND STEEL PROVISION

I agree that I will obtain identical certifications from prospective lower-tier construction subcontractors prior to the award of any lower-tier construction subcontracts with a price exceeding \$2,000. I also agree that I will retain such certifications in my files.

(Name of Prospective Construction Contractor or Subcontractor [Print or Type])

(Street Address)

(City)

(State)

(Zip Code)

Phone number

(Employer Identification Number)

(Name and Title of Authorized Official [Print or Type])

(Signature of Authorized Official)

(Date)

**APPENDIX B TO THE FLORIDA DEPARTMENT OF ENVIRONMENTAL PROTECTION
SUPPLEMENTARY CONDITIONS**

GOALS AND TIMETABLES FOR MINORITIES AND FEMALES

[Note: These goals and timetables are the goals and timetables referred to in Paragraph 2 of the "Notice of Requirement for Affirmative Action to Ensure Equal Employment Opportunity (Executive Order 11246)"; these goals and timetables are to be included in all FDEP assisted construction contracts and subcontracts with a price exceeding \$10,000 and in all solicitations for such contracts and subcontracts.]

The following goals and timetables for female utilization shall be included in all federal and federally assisted construction contracts and subcontracts in excess of \$10,000. The goals are applicable to the contractor's aggregate on-site construction workforce whether or not part of that workforce is performing work on a federal or federally assisted construction contract or subcontract.

Area covered: Goals for Women apply nationwide.

Goals and Timetables

Timetable	Goals (percent)
Indefinite	6.9

Goals for minority utilization can be found in the Department of Labor's Technical Assistance Guide for Federal Construction Contractors, available at https://www.dol.gov/ofcep/taguides/TAC_FedContractors_JRF_QA_508c.pdf. These goals shall be included for each craft and trade in all federal or federally assisted construction contracts and subcontracts in excess of \$10,000 to be performed in the respective geographical areas. The goals are applicable to each nonexempt contractor's total onsite construction workforce, regardless of whether or not part of that workforce is performing work on a federal, federally assisted or non-federally related project, contract or subcontract.

Construction contractors which are participating in an approved Hometown Plan (see 41 CFR 60-4.5) are required to comply with the goals of the Hometown Plan with regard to construction work they perform in the area covered by the Hometown Plan. With regard to all their other covered construction work, such contractors are required to comply with the applicable SMSA or EA goal contained in this Appendix.

APPENDIX C
TO THE FLORIDA DEPARTMENT OF ENVIRONMENTAL PROTECTION
SUPPLEMENTARY CONDITIONS

Davis-Bacon Requirements

FEDERAL LABOR STANDARDS PROVISIONS

(Davis-Bacon Act, Copeland Act, and Contract Works Hours & Safety Standards Act)

The Project to which the construction work covered by this contract pertains is being assisted by the United States of America and the following Federal Labor Standards Provisions are included in this Contract pursuant to the provisions applicable to such federal assistance.

1 Minimum Wages.

(i) All laborers and mechanics employed or working upon the site of the work (or under the United States Housing Act of 1937 or under the Housing Act of 1949 in the construction or development of the project), will be paid unconditionally and not less often than once a week, and without subsequent deduction or rebate on any account (except such payroll deductions as are permitted by regulations issued by the Secretary of Labor under the Copeland Act, 29 CFR Part 3, the full amount of wages and bona fide fringe benefits (or cash equivalents thereof) due at time of payment computed at rates not less than those contained in the wage determination of the Secretary of Labor which is attached hereto and made a part hereof, regardless of any contractual relationship which may be alleged to exist between the contractor and such laborers and mechanics. Contributions made or costs reasonably anticipated for bona fide fringe benefits under Section 1(b)(2) of the Davis-Bacon Act on behalf of laborers or mechanics are considered wages paid to such laborers or mechanics, subject to the provisions of 29 CFR 5.5(a)(1)(iv); also, regular contributions made or costs incurred for more than a weekly period (but not less often than quarterly) under plans, funds, or programs, which cover the particular weekly period, are deemed to be constructively made or incurred during such weekly period.

Such laborers and mechanics shall be paid the appropriate wage rate and fringe benefits on the wage determination for the classification of work actually performed, without regard to skill, except as provided in 29 CFR Part 5.5(a)(4). Laborers or mechanics performing work in more than one classification may be compensated at the rate specified for each classification for the time actually worked therein; provided, that the employer's payroll records accurately set forth the time spent in each classification in which work is performed. The wage determination (including any additional classification and wage rates conformed under 29 CFR Part 5.5(a)(1)(ii) and the Davis-Bacon poster (WH-1321) shall be posted at all times by the contractor and its subcontractors at the site of the work in a prominent and accessible place where it can be easily seen by the workers.

(ii) (a) The sponsor, on behalf of EPA, shall require that any class of laborers or mechanics, including helpers, which is not listed in the wage determination and which is to be employed under the contract shall be classified in conformance with the wage determination. The FDEP shall approve a request for an additional classification and wage rate and fringe benefits; therefore, only when the following criteria have been met:

- (1) The work to be performed by the classification requested is not performed by a classification in the wage determination; and
- (2) The classification is utilized in the area by the construction industry; and
- (3) The proposed wage rate, including any bona fide fringe benefits, bears a reasonable relationship to the wage rates contained in the wage determination.

(b) If the contractor and the laborers and mechanics to be employed in the classification (if known), or their representatives, and the sponsor(s) agree on the classification and wage rate (including the amount designated for fringe benefits where appropriate), a report of the action taken shall be sent by the sponsor to the FDEP. The FDEP will transmit the request to the Administrator of the Wage and Hour Division, employment Standards Administration, U. S. Department of Labor. The Administrator, or an authorized representative, will approve, modify, or disapprove every additional

classification action within 30 days of receipt and so advise the FDEP or will notify FEDP within the 30-day period that additional time is necessary. (Approved by the Office of Management and Budget under OMB control number 1215-0140.)

(c) In the event that the Contractor, the laborers or mechanics to be employed in the Classification or their representatives, and the sponsor do not agree on the proposed classification and wage rate (including the amount designed for fringe benefits, where appropriate), the FDEP shall refer the request and the local wage determination, including the views of all interested parties and the recommendation of FDEP, to the Administrator for determination. The Administrator, or an authorized representative, will issue a determination within 30 days of receipt of the request and so advise the contracting officer or will notify the contracting officer within the 30-day period that additional time is necessary. (Approved by the Office of Management and Budget under OMB Control Number 1215-0140.)

(d) The wage rate (including fringe benefits where appropriate) determined pursuant to subparagraphs (1)(b) or (c) of this paragraph, shall be paid to all workers performing work in the classification under this contract from the first day on which work is performed in the classification.

(iii) Whenever the minimum wage rate prescribed in the contract for a class of laborers or mechanics includes a fringe benefit which is not expressed as an hourly rate, the contractor shall either pay the benefit as stated in the wage determination or shall pay another bona fide fringe benefit or an hourly cash equivalent thereof.

(iv) If the contractor does not make payments to a trustee or other third person, the contractor may consider as part of the wages of any laborer or mechanic the amount of any costs reasonably anticipated in providing bona fide fringe benefits under a plan or program. Provided, that the Secretary of Labor has found, upon the written request of the contractor, that the applicable standards of the Davis-Bacon Act have been met. The Secretary of Labor may require the contractor to set aside in a separate account, assets for the meeting of obligations under the plan or program. (Approved by the Office of Management and Budget under OMB Control Number 1215-0140.)

2. Withholding.

The sponsor shall, upon written request of the EPA or an authorized representative of the Department of Labor, withhold or cause to be withheld from the contractor under this contract or any other federal contract with the same prime contractor, or any other federally-assisted contract subject to Davis-Bacon prevailing wage requirements, which is held by the same prime contractor so much of the accrued payments or advances as may be considered necessary to pay laborers and mechanics, including apprentices, trainees and helpers employed by the contractor or any subcontractor the full amount of wages required by the contract. In the event of failure to pay any laborer or mechanic, including any apprentice, trainee or helper, employed or working on the site of the work (or under the United States Housing Act of 1937 or under the Housing Act of 1949 in the construction or development of the project), all or part of the wages required by the contract, EPA may, after written notice to the contractor, sponsor, applicant, or owners, take such action as may be necessary to cause the suspension of any further payment, advance, or guarantee of funds until such violations have ceased.

3. Payrolls and Basic Records.

(i) Payrolls and basic records relating thereto shall be maintained by the contractor during the course of the work and preserved for a period of three years thereafter for all laborers and mechanics working at the site of the work (or under the United States Housing Act of 1937, or under the Housing Act of 1949, in the construction or development of the project). Such records shall contain the name, address, and social security number of each such worker, his or her correct classification, hourly rates of wages paid (including rates of contributions or costs anticipated for bona fide fringe benefits or cash equivalents thereof of the types described in Section 1(b)(2)(B) of the Davis-Bacon Act), daily and weekly number of hours worked, deductions made and actual wages paid. Whenever the Secretary of Labor has found under 29 CFR 5.5(a)(1)(iv) that the wages of any laborer or mechanic include the amount of any costs reasonably anticipated in providing benefits under a plan or program described in Section 1(b)(2)(B) of the Davis-Bacon Act, the contractor shall maintain records which show that the commitment to provide such benefits is enforceable, that the plan or program is financially responsible, and that the plan or program has been communicated in writing to the laborers or mechanics affected, and records which show the costs anticipated or the actual cost incurred in providing such benefits. Contractors employing apprentices or trainees under approved programs shall maintain written evidence of the registration of apprenticeship programs and certification of trainee programs, the registration of the apprentices and trainees, and the ratios and wage rates prescribed in the applicable programs. (Approved by the Office of Management and Budget under OMB Control Numbers 1215-0140 and 1215-0017).

(ii) (a) The contractor shall submit weekly for each week in which any contract work is performed, a copy of all payrolls to the sponsor. Such documentation shall be available upon request by FDEP. As to each payroll copy received, the sponsor shall provide a certification that the project is in compliance with the requirements of 29 CFR 5.5(a)(1) with each disbursement request. The payrolls submitted shall set out accurately and completely all of the information required to be maintained under 29 CFR Part 5.5(a)(3)(I), except that full social security numbers and home addresses shall not be included on the weekly payrolls. Instead, the payrolls shall only need to include an individually identifying number for each employee (e.g., the last four digits of the employee's social security number). The required weekly payroll information may be submitted in any form desired. Optional Form WH-347 is available for this purpose from the Wage and Hour Division Web site <http://www.dol.gov/whd/forms/wh347instr.htm> or its successor site. The prime contractor is responsible for the submission of copies of payrolls by all subcontractors. Contractors and subcontractors shall maintain the full social security number and current addresses of each covered worker, and shall provide them upon request to the sponsor for transmission to the FDEP or EPA if requested by EPA, the FDEP, the contractor, or the Wage and Hour Division of the Department of Labor for purposes of an investigation or audit of compliance with prevailing wage requirements. It is not a violation of this section for a prime contractor to require a subcontractor to provide addresses and social security numbers to the prime contractor for its own records, without weekly submission to the sponsor. (Approved by the Office of Management and Budget under OMB Control Number 1215-0149).

(b) Each payroll submitted shall be accompanied by a Statement of Compliance, signed by the contractor or subcontractor or his or her agent who pays or supervises the payment of the persons employed under the contract and shall certify the following:

(1) That the payroll for the payroll period contains the information required to be provided under 29 CFR Part 5.5(a)(3)(ii), the appropriate information is being maintained under 29 CFR Part 5.5 (a)(3)(I), and that such information is correct and complete;

(2) That each laborer or mechanic (including each helper, apprentice, and trainee) employed on the contract during the payroll period has been paid the full weekly wages earned, without rebate, either directly or indirectly, and that no deductions have been made either directly or indirectly from the full wages earned, other than permissible deductions as set forth in 29 CFR Part 3;

(3) That each laborer or mechanic has been paid not less than the applicable wage rates and fringe benefits or cash equivalents for the classification of work performed, as specified in the applicable wage determination incorporated into the contract.

(c) The weekly submission of a properly executed certification set forth on the reverse side of Option Form WH-347 shall satisfy the requirement for submission of the Statement of Compliance required by paragraph A. 3(ii)(b) of this section.

(d) The falsification of any of the above certifications may subject the contractor or subcontractor to civil or criminal prosecution under Section 1001 of Title 18 and Section 231 of Title 31 of the United States Code.

(iii) The contractor or subcontractor shall make the records required under paragraph A.3(I) of this section available for inspection, copying, or transcription by authorized representatives of the FDEP or the Department of Labor, and shall permit such representatives to interview employees during working hours on the job. If the contractor or subcontractor fails to submit the required records or to make them available, the FDEP may, after written notice to the contractor, or sponsor, take such action as may be necessary to cause the suspension of any further payment, advance, or guarantee of funds. Furthermore, failure to submit the required records upon request to make such records available may be grounds for debarment action pursuant to 29 CFR Part 5.12.

4. Apprentices and Trainees.

(i) Apprentices. Apprentices will be permitted to work at less than the predetermined rate for the work they performed when they are employed pursuant to and individually registered in a bona fide apprenticeship program registered with the U. S. Department of Labor, the Employment and Training Administration, Office of Apprenticeship Training, Employer and Labor Services, or with a State Apprenticeship Agency recognized by the Office, or if a person is employed in his or her first 90 days of probationary employment as an apprentice in such an apprenticeship program, who is not individually registered in the program, but who has been certified by the Office of Apprenticeship Training, Employer and Labor Services, or a State Apprenticeship Agency (where appropriate) to be eligible for probationary employment as an apprentice. The allowable ratio

of apprentices to journeymen on the job site in any craft classification shall not be greater than the ratio permitted to the contractor as to the entire work force under the registered program. Any worker listed on a payroll at an apprentice wage rate, who is not registered or otherwise employed as stated above, shall be paid not less than the applicable wage rate on the wage determination for the classification of work actually performed. In addition, any apprentice performing work on the job site in excess of the ratio permitted under the registered program, shall be paid not less than the applicable wage rate on the wage determination for the work actually performed. Where a contractor is performing construction on a project in a locality other than that in which its program is registered, the ratios and wage rates (expressed in percentages of the journeyman's hourly rate) specified in the contractor's or subcontractor's registered program shall be observed. Every apprentice must be paid at not less than the rate specified in the registered program for the apprentice's level of progress, expressed as a percentage of the journeymen hourly rate specified in the applicable wage determination. Apprentices shall be paid fringe benefits in accordance with the provisions of the apprenticeship program. If the apprenticeship program does not specify fringe benefits, apprentices must be paid the full amount of fringe benefits listed on the wage determination for the applicable classification. If the Administrator determines that a different practice prevails for the applicable apprentice classification, fringes shall be paid in accordance with the determination. In the event the Office of Apprenticeship Training, Employer and Labor Services, or a State Apprenticeship Agency recognized by the Office, withdraws approval of an apprenticeship program, the contractor will no longer be permitted to utilize apprentices at less than the applicable predetermined rate for the work performed until an acceptable program is approved.

(ii) Trainees. Except as provided in 29 CFR 5.16, trainees will not be permitted to work at less than the predetermined rate for the work performed unless they are employed pursuant to and individually registered in a program which has received prior approval, evidenced by formal certification by the U. S. Department of Labor, the Employment and Training Administration. The ratio of trainees to journeymen on the job site shall not be greater than permitted under the plan approved by the Employment and Training Administration. Every trainee must be paid at not less than the rate specified in the approved program for the trainee's level of progress, expressed as a percentage of the journeyman hourly rate specified in the applicable wage determination. Trainees shall be paid fringe benefits in accordance with the provisions of the trainee program. If the trainee program does not mention fringe benefits, trainees shall be paid the full amount of fringe benefits listed on the wage determination unless the Administrator of the Wage and Hour Division determines that there is an apprenticeship program associated with the corresponding journeyman wage rate on the wage determination which provides for less than full fringe benefits for apprentices. Any employee listed on the payroll at a trainee rate who is not registered and participating in a training plan approved by the Employment and Training Administration shall be paid not less than the applicable wage rate on the wage determination for the work actually performed. In addition, any trainee performing work on the job site in excess of the ratio permitted under the registered program shall be paid not less than the applicable wage rate on the wage determination for the work actually performed. In the event the Employment and Training Administration withdraws approval of a training program the contract will no longer be permitted to utilize trainees at less than the applicable predetermined rate for the work performed until an acceptable program is approved.

(iii) Equal Employment Opportunity. The utilization of apprentices, trainees and journeymen under this part shall be in conformity with the equal employment opportunity requirements of Executive Order 11246, as amended, and 29 CFR Part 30.

5. Compliance with Copeland Act Requirements.

The contractor shall comply with the requirements of 29 CFR Part 3 which are incorporated by reference in this contract.

6. Subcontracts.

The contractor or subcontractor will insert in any subcontracts the clauses contained in 29 CFR 5.5(a)(1) through (10) and such other clauses as EPA determines may be appropriate, and also a clause requiring the subcontractors to include these clauses in any lower tier subcontracts. The prime contractor shall be responsible for the compliance by any subcontractor or lower tier subcontractor with all the contract clauses in 29 CFR Part 5.5.

7. Contract Termination, Debarment.

A breach of the contract clauses in 29 CFR 5.5 may be grounds for termination of the contract and for debarment as a contractor and a subcontractor as provided in 29 CFR 5.12.

8. Compliance with Davis-Bacon and Related Act Requirements.

All rulings and interpretations of the Davis-Bacon and Related Acts contained in 29 CFR Parts 1, 3 and 5 are herein incorporated by reference in this contract.

9. Disputes Concerning Labor Standards.

Disputes arising out of the labor standards provisions of this contract shall not be subject to the general disputes clause of this contract. Such disputes shall be resolved in accordance with the procedures of the Department of Labor set forth in 29 CFR Parts 5, 6 and 7. Disputes within the meaning of this clause include disputes between the contractor (or any of its subcontractors) and the sponsor, FDEP, EPA, the U. S. Department of Labor, or the employees or their representatives:

10. Certification of Eligibility.

(i) By entering into this contract, the contractor certifies that neither it (nor he or she) nor any person or firm who has an interest in the contractor's firm is a person or firm ineligible to be awarded government contracts by virtue of Section 3(a) of the Davis-Bacon Act or 29 CFR 5.12(a)(1) or to be awarded EPA contracts or participate in EPA programs pursuant to Executive Order 12549.

(ii) No part of this contract shall be subcontracted to any person or firm ineligible for award of a government contract by virtue of Section 3(a) of the Davis-Bacon Act or 29 CFR 5.12(a)(1) or to be awarded EPA contracts or participate in EPA programs pursuant to Executive Order 12549.

(iii) The penalty for making false statements is prescribed in the U. S. Criminal Code, 18 U. S. C. 1001. Additionally, U. S. Criminal Code, Section 1010, Title 18, U. S. C., Federal Housing Administration transactions, provides in part "Whoever, for the purpose of . . . influencing in any way the action of such Administration . . . makes, utters or publishes any statement, knowing the same to be false . . . shall be fined not more than \$5,000 or imprisoned not more than two years, or both".

11. Complaints, Proceedings, or Testimony by Employees.

A. No laborer or mechanic to whom the wage, salary, or other labor standards provisions of this contract are applicable shall be discharged or in any other manner discriminated against by the contractor or any subcontractor because such employee has filed any complaint or instituted or caused to be instituted any proceeding or has testified or is about to testify in any proceeding under or relating to the labor standards applicable under this contract to his employer.

B. **Contract Work Hours and Safety Standards Act.** The sponsor shall insert the following clauses set forth in paragraphs B.(1), (2), (3), and (4) of this section in full in any contract in an amount in excess of \$100,000 and subject to the overtime provisions of the Contract Work Hours and Safety Standards Act. These clauses shall be inserted in addition to the clauses required by item 3 above or 29 CFR 4.6. As used in the paragraph, the terms laborers and mechanics include watchmen and guards.

(1) **Overtime requirements.** No contractor or subcontractor contracting for any part of the contract work which may require or involve the employment of laborers or mechanics shall require or permit any such laborer or mechanic in any workweek in which he or she is employed on such work to work in excess of forty hours in such workweek unless such laborer or mechanic receives compensation at a rate not less than one and one-half times the basic rate of pay for all hours worked in excess of forty hours in such workweek.

(2) **Violation; liability for unpaid wages; liquidated damages.** In the event of any violation of the clause set forth in subparagraph (1) of this paragraph, the contractor and any subcontractor responsible therefore shall be liable for the unpaid wages. In addition, such contractor and subcontractor shall be liable to the United States (in the case of work done under contract for the District of Columbia or a territory, to such District or to such territory), for liquidated damages. Such liquidated damages shall be computed with respect to each individual laborer or mechanic, including watchmen and guards, employed in violation of the clause set forth in subparagraph (1) of this paragraph, in the sum of \$10 for each calendar day on which such individual was required or permitted to work in excess of the standard workweek of forty hours without payment of the overtime wages required by the clause set forth in subparagraph (1) of this paragraph.

(3) **Withholding for unpaid wages and liquidated damages.** The sponsor, upon written request of the FDEP or an authorized representative of the Department of Labor, may withhold or cause to be withheld, from any moneys payable on

account of work performed by the contractor or subcontractor under any such contract or any other federal contract with the same prime contract, or any other federally-assisted contract subject to the Contract Work Hours and Safety Standards Act, which is held by the same prime contractor, such sums as may be determined to be necessary to satisfy any liabilities of such contractor or subcontractor for unpaid wages and liquidated damages as provided in the clause set forth in subparagraph (2) of this paragraph.

(4) Subcontracts. The contractor or subcontractor shall insert in any subcontracts the clauses set forth in subparagraph (1) through (4) of this paragraph and also a clause requiring the subcontractors to include these clauses in any lower tier subcontracts. The prime contractor shall be responsible for compliance by any subcontractor or lower tier subcontractor with the clauses set forth in subparagraphs (1) through (4) of this paragraph.

C. Health and Safety

(1) No laborer or mechanic shall be required to work in surroundings or under working conditions which are unsanitary, hazardous, or dangerous to his health and safety as determined under construction safety and health standards promulgated by the Secretary of Labor by regulation.

(2) The contractor shall comply with all regulations issued by the Secretary of Labor pursuant to Title 29 Part 1926 (formerly part 1518) and failure to comply may result in imposition of sanctions pursuant to the Contract Work Hours and Safety Standards Act (Public Law 91-54.83 State 96).

(3) The contractor shall include the provisions of this Article in every subcontract so that such provisions will be binding on each subcontractor. The contractor shall take such action with respect to any subcontract as the Secretary of Housing and Urban Development or the Secretary of Labor shall direct as a means of enforcing such provisions.

12. Guidance to Contractor for Compliance with Labor Standards Provisions

a) Contracts with Two Wage Decisions

If the contract includes two wage decisions, the contractor, and each subcontractor who works on the site, must submit either two separate payrolls (one for each wage decision) or one payroll which identifies each worker twice and the hours worked under each wage decision. One single payroll, reflecting each worker once, may be submitted provided the Contractor uses the higher rate in the wage decisions for each identical job classification. However, where a job classification is not listed in a wage decision and is needed for that portion of the work, the classification must be added to the wage decision. A worker may not be paid at the rate for a classification using the hourly rate for that same classification in another wage decision. After the additional classification is approved, the contractor may pay the higher of the two rates and submit one payroll, if desired.

b) Complying with Minimum Hourly Amounts

1) The minimum hourly amount due to a worker in each classification is the total of the amounts in the Rates and Fringe Benefits (if any) columns of the applicable wage decision.

2) The contractor may satisfy this minimum hourly amount by any combination of cash and bona fide fringe benefits, regardless of the individual amounts reflected in the Rates and Fringe Benefits columns.

3) A contractor payment for a worker which is required by law is not a fringe benefit in meeting the minimum hourly amount due under the applicable wage decision. For example, contractor payments for FICA or unemployment insurance are not a fringe benefit; however, contractor payments for health insurance or retirement are a fringe benefit. Generally, a fringe benefit is bona fide if (a) it is available to most workers and (b) involves payments to a third party.

4) The hourly value of the fringe benefit is calculated by dividing the contractor's annual cost (excluding any amount contributed by the worker) for the fringe benefit by 2080. Therefore, for workers with overtime, an additional payment may be required to meet the minimum hourly wages since generally fringe benefits have no value for any time worked over 40 hours weekly. (If a worker is paid more than the minimum rates required by the wage decision, this should not be a problem. As long as the total wages received by a worker for straight time equals the hours worked times the minimum hourly rate in the wage decision, the requirement of the Davis-Bacon and Related Acts has been satisfied.)

c) Overtime

For any project work over 40 hours weekly, a worker generally must be paid 150% of the actual hourly cash rate received, not the minimum required by the wage decision. (The Davis-Bacon and Related Acts only establishes minimum rates and does not address overtime. The Contract Work Hours Act contains the overtime requirement and uses basic rate of pay as the base for calculation, not the minimum rates established by the Davis-Bacon and Related Acts.)

d) Deductions

Workers who have deductions, not required by law, from their pay must authorize these deductions in writing. The authorization must identify the purpose of each deduction and the amount, which may be a specific dollar amount or a percentage. A copy of the authorization must be submitted with the first payroll containing the deduction. If deducted amounts increase, another authorization must be submitted. If deducted amounts decrease, no revision to the original authorization is needed. Court-ordered deductions, such as child support, may be identified by the responsible payroll person in a separate document. This document should identify the worker, the amount deducted and the purpose. A copy of the court order should be submitted.

e) Classifications Not Included in the Wage Decision

If a classification not in the wage decision is required, please advise the owner's representative in writing and identify the job classification(s) required. In some instances, the state agency may allow the use of a similar classification in the wage decision.

Otherwise, the contractor and affected workers must agree on a minimum rate, which cannot be lower than the lowest rate for any trade in the wage decision. Laborers (including any subcategory of the laborer classification) and truck drivers are not considered a trade for this purpose. If the classification involves a power equipment operator, the minimum cannot be lower than the lowest rate for any power equipment operator in the wage decision. The owner will provide forms to document agreement on the minimum rate by the affected workers and contractor.

The U.S. Department of Labor (USDOL) must approve the proposed classification and rate. The contractor may pay the proposed rate until the USDOL makes a determination. Should the USDOL require a higher rate, the contractor must make wage restitution to the affected worker(s) for all hours worked under the proposed rate.

f) Supervisory Personnel

Foremen and other supervisory personnel who spend at least 80% of their time supervising workers are not covered by the Davis-Bacon and Related Acts. Therefore, a wage decision will not include such supervisory classifications and their wages are not subject to any minimums under the Davis-Bacon and Related Act or overtime payments under the Contract Work Hours and Safety Standards Act. However, foremen and other supervisory personnel who spend less than 80% of their time engaged in supervisory activities are considered workers/mechanics for the time spent engaged in manual labor and must be paid at least the minimum in the wage decision for the appropriate classification(s) based on the work performed.

g) Sole Proprietorships / Independent Contractors / Leased Workers

The nature of the relationship between a prime contractor and a worker does not affect the requirement to comply with the labor standards provisions of this contract. The applicability of the labor standards provisions is based on the nature of the work performed.

If the work performed is primarily manual in nature, the worker is subject to the labor standards provisions in this contract. For example, if John Smith is the owner of ABC Plumbing and performs all plumbing work himself, then Mr. Smith is subject to the labor standards provisions, including minimum wages and overtime. His status as owner is irrelevant for labor standards purposes.

If a worker meets the IRS standards for being an independent contractor, and is employed as such, this means that the worker must submit a separate payroll as a subcontractor rather than be included on some other payroll. The worker is still subject to the labor standards provisions in this contract, including minimum wages and overtime.

If a contractor or subcontractor leases its workers, they are subject to the labor standards provisions in this contract, including minimum wages and overtime. The leasing firm must submit payrolls and these payrolls must reflect information required to determine compliance with the labor standards provisions of this contract, including a classification for each worker based on the nature of the work performed, number of regular hours worked, and number of overtime hours worked.

h) Apprentices / Helpers

A worker may be classified as an apprentice only if participating in a federal or state program. Documentation of participation must be submitted. Generally, the apprentice program specifies that the apprentice will be compensated at a percentage of journeyman rate. For Davis-Bacon Act purposes, the hourly rate cannot be lower than the percentage of the hourly rate for the classification in the applicable wage decision.

If the worker does not participate in a federal or state apprentice program, then the worker must be classified according to duties performed. This procedure may require classification in the trade depending on tools used, or as a laborer if specialized tools of the trade are not used. The contractor may want to consult with the Wage and Hour Division of the U.S. Department of Labor located in most large cities regarding the appropriate classification.

Presently, no worker may be classified as a helper. As with apprentices not participating in a formal apprentice program, the worker must be classified according to duties performed and tools used.

**APPENDIX D TO THE FLORIDA DEPARTMENT OF ENVIRONMENTAL PROTECTION
SUPPLEMENTARY CONDITIONS**

American Iron and Steel Requirement

The Contractor acknowledges to and for the benefit of _____ ("Owner") and the State of Florida (the "State") that it understands that iron and steel products to be installed as a part of this contract must be in compliance with the Federal American Iron Steel (AIS) requirements. For Clean Water SRF funded projects, the AIS requirements can be found in Section 608 of the Federal Water Pollution Control Act (Clean Water Act). Section 608 of the Clean Water Act (33 U.S.C. 1388) includes the following language:

(a) In general

Funds made available from a State water pollution control revolving fund established under this title may not be used for a project for the construction, alteration, maintenance, or repair of treatment works unless all of the iron and steel products used in the project are produced in the United States.

(b) Definition of iron and steel products

In this section, the term "iron and steel products" means the following products made primarily of iron or steel: lined or unlined pipes and fittings, manhole covers and other municipal castings, hydrants, tanks, flanges, pipe clamps and restraints, valves, structural steel, reinforced precast concrete, and construction materials.

(c) Application

Subsection (a) shall not apply in any case or category of cases in which the Administrator finds that—

- (1) applying subsection (a) would be inconsistent with the public interest;
- (2) iron and steel products are not produced in the United States in sufficient and reasonably available quantities and of a satisfactory quality; or
- (3) inclusion of iron and steel products produced in the United States will increase the cost of the overall project by more than 25 percent.

(d) Waiver

If the Administrator receives a request for a waiver under this section, the Administrator shall make available to the public, on an informal basis, a copy of the request and information available to the Administrator concerning the request, and shall allow for informal public input on the request for at least 15 days prior to making a finding based on the request. The Administrator shall make the request and accompanying information available by electronic means, including on the official public Internet site of the Environmental Protection Agency.

(e) International agreements

This section shall be applied in a manner consistent with United States obligations under international agreements.

For Drinking Water SRF funded projects, the AIS requirements are in Public Law 113-76 and continue in force under continuing resolutions that use similar language, including Section 424 of the "Consolidated Appropriations Act, 2016."

Notwithstanding any other provision of this Agreement, any failure to comply with AIS requirements by the Contractor shall permit the Purchaser or State to recover as damages against the Contractor any loss, expense, or cost (including without limitation attorney's fees) incurred by the Purchaser or State resulting from any such failure (including without limitation any impairment or loss of funding, whether in whole or in part, from the State or any damages owed to the State by the Purchaser). While the Contractor has no direct contractual privity with the State, as a lender to the Purchaser for the funding of its project, the Purchaser and the Contractor agree that the State is a third-party beneficiary and neither this paragraph (nor any other provision of this Agreement necessary to give this paragraph force or effect) shall be amended or waived without the prior written consent of the State.

For waivers to these requirements based on (c) above, contact the State Revolving Fund Program at (850) 245-2835 or SRF_Reporting@dep.state.fl.us.

General Decision Number: FL170178 08/04/2017 FL178

Superseded General Decision Number: FL20160178

State: Florida

Construction Type: Heavy

County: St Johns County in Florida.

HEAVY CONSTRUCTION PROJECTS (Including Sewer and Water Lines)

Note: Under Executive Order (EO) 13658, an hourly minimum wage of \$10.20 for calendar year 2017 applies to all contracts subject to the Davis-Bacon Act for which the contract is awarded (and any solicitation was issued) on or after January 1, 2015. If this contract is covered by the EO, the contractor must pay all workers in any classification listed on this wage determination at least \$10.20 (or the applicable wage rate listed on this wage determination, if it is higher) for all hours spent performing on the contract in calendar year 2017. The EO minimum wage rate will be adjusted annually. Additional information on contractor requirements and worker protections under the EO is available at www.dol.gov/whd/govcontracts.

Modification Number	Publication Date
0	01/06/2017
1	02/10/2017
2	08/04/2017

ELEC0177-002 01/02/2017

	Rates	Fringes
ELECTRICIAN.....	\$ 26.90	11.60

ENGI0673-014 05/01/2013

	Rates	Fringes
OPERATOR: Oiler.....	\$ 19.52	9.05

IRON0597-004 04/01/2016

	Rates	Fringes
IRONWORKER, STRUCTURAL AND REINFORCING.....	\$ 24.00	9.40

* LABO0517-002 05/01/2017

	Rates	Fringes
LABORER: Grade Checker.....	\$ 19.20	7.85

PAIN0164-007 08/01/2014

	Rates	Fringes
--	-------	---------

PAINTER: Brush Only.....\$ 19.50 8.83

 SUFL2009-174 06/24/2009

	Rates	Fringes
CARPENTER.....	\$ 15.80	0.00
CEMENT MASON/CONCRETE FINISHER...\$	13.23	2.15
LABORER: Common or General.....\$	9.89	1.58
LABORER: Landscape.....\$	7.25	0.00
LABORER: Pipelayer.....\$	12.85	1.21
LABORER: Power Tool Operator (Hand Held Drills/Saws, Jackhammer and Power Saws Only).....\$	10.63	2.20
OPERATOR: Asphalt Paver.....\$	11.59	0.00
OPERATOR: Backhoe Loader Combo.....\$	16.10	2.44
OPERATOR: Backhoe/Excavator.....\$	13.91	1.39
OPERATOR: Bulldozer.....\$	13.40	1.19
OPERATOR: Crane.....\$	22.38	0.00
OPERATOR: Grader/Blade.....\$	16.00	2.84
OPERATOR: Loader.....\$	11.31	2.02
OPERATOR: Mechanic.....\$	14.32	0.00
OPERATOR: Roller.....\$	10.93	0.00
OPERATOR: Scraper.....\$	11.00	1.74
OPERATOR: Trackhoe.....\$	20.92	5.50
OPERATOR: Tractor.....\$	10.54	0.00
TRUCK DRIVER, Includes Dump Truck.....\$	14.63	0.00
TRUCK DRIVER: Lowboy Truck.....\$	13.06	2.18
TRUCK DRIVER: Off the Road Truck.....\$	12.21	1.97

 WELDERS - Receive rate prescribed for craft performing
 operation to which welding is incidental.
 =====

Note: Executive Order (EO) 13706, Establishing Paid Sick Leave for Federal Contractors applies to all contracts subject to the Davis-Bacon Act for which the contract is awarded (and any solicitation was issued) on or after January 1, 2017. If this contract is covered by the EO, the contractor must provide employees with 1 hour of paid sick leave for every 30 hours they work, up to 56 hours of paid sick leave each year. Employees must be permitted to use paid sick leave for their own illness, injury or other health-related needs, including preventive care; to assist a family member (or person who is like family to the employee) who is ill, injured, or has other health-related needs, including preventive care; or for reasons resulting from, or to assist a family member (or person who is like family to the employee) who is a victim of, domestic violence, sexual assault, or stalking. Additional information on contractor requirements and worker protections under the EO is available at www.dol.gov/whd/govcontracts.

Unlisted classifications needed for work not included within the scope of the classifications listed may be added after award only as provided in the labor standards contract clauses (29CFR 5.5 (a) (1) (ii)).

The body of each wage determination lists the classification and wage rates that have been found to be prevailing for the cited type(s) of construction in the area covered by the wage determination. The classifications are listed in alphabetical order of "identifiers" that indicate whether the particular rate is a union rate (current union negotiated rate for local), a survey rate (weighted average rate) or a union average rate (weighted union average rate).

Union Rate Identifiers

A four letter classification abbreviation identifier enclosed in dotted lines beginning with characters other than "SU" or "UAVG" denotes that the union classification and rate were prevailing for that classification in the survey. Example: PLUM0198-005 07/01/2014. PLUM is an abbreviation identifier of the union which prevailed in the survey for this classification, which in this example would be Plumbers. 0198 indicates the local union number or district council number where applicable, i.e., Plumbers Local 0198. The next number, 005 in the example, is an internal number used in processing the wage determination. 07/01/2014 is the effective date of the most current negotiated rate, which in this example is July 1, 2014.

Union prevailing wage rates are updated to reflect all rate changes in the collective bargaining agreement (CBA) governing this classification and rate.

Survey Rate Identifiers

Classifications listed under the "SU" identifier indicate that

no one rate prevailed for this classification in the survey and the published rate is derived by computing a weighted average rate based on all the rates reported in the survey for that classification. As this weighted average rate includes all rates reported in the survey, it may include both union and non-union rates. Example: SULA2012-007 5/13/2014. SU indicates the rates are survey rates based on a weighted average calculation of rates and are not majority rates. LA indicates the State of Louisiana. 2012 is the year of survey on which these classifications and rates are based. The next number, 007 in the example, is an internal number used in producing the wage determination. 5/13/2014 indicates the survey completion date for the classifications and rates under that identifier.

Survey wage rates are not updated and remain in effect until a new survey is conducted.

Union Average Rate Identifiers

Classification(s) listed under the UAVG identifier indicate that no single majority rate prevailed for those classifications; however, 100% of the data reported for the classifications was union data. EXAMPLE: UAVG-OH-0010 08/29/2014. UAVG indicates that the rate is a weighted union average rate. OH indicates the state. The next number, 0010 in the example, is an internal number used in producing the wage determination. 08/29/2014 indicates the survey completion date for the classifications and rates under that identifier.

A UAVG rate will be updated once a year, usually in January of each year, to reflect a weighted average of the current negotiated/CBA rate of the union locals from which the rate is based.

WAGE DETERMINATION APPEALS PROCESS

1.) Has there been an initial decision in the matter? This can be:

- * an existing published wage determination
- * a survey underlying a wage determination
- * a Wage and Hour Division letter setting forth a position on a wage determination matter
- * a conformance (additional classification and rate) ruling

On survey related matters, initial contact, including requests for summaries of surveys, should be with the Wage and Hour Regional Office for the area in which the survey was conducted because those Regional Offices have responsibility for the Davis-Bacon survey program. If the response from this initial contact is not satisfactory, then the process described in 2.) and 3.) should be followed.

With regard to any other matter not yet ripe for the formal process described here, initial contact should be with the Branch of Construction Wage Determinations. Write to:

Branch of Construction Wage Determinations
Wage and Hour Division
U.S. Department of Labor
200 Constitution Avenue, N.W.
Washington, DC 20210

2.) If the answer to the question in 1.) is yes, then an interested party (those affected by the action) can request review and reconsideration from the Wage and Hour Administrator (See 29 CFR Part 1.8 and 29 CFR Part 7). Write to:

Wage and Hour Administrator
U.S. Department of Labor
200 Constitution Avenue, N.W.
Washington, DC 20210

The request should be accompanied by a full statement of the interested party's position and by any information (wage payment data, project description, area practice material, etc.) that the requestor considers relevant to the issue.

3.) If the decision of the Administrator is not favorable, an interested party may appeal directly to the Administrative Review Board (formerly the Wage Appeals Board). Write to:

Administrative Review Board
U.S. Department of Labor
200 Constitution Avenue, N.W.
Washington, DC 20210

4.) All decisions by the Administrative Review Board are final.

=====

END OF GENERAL DECISION



St. Johns County Board of County Commissioners

Purchasing Division

November 14, 2017

Mr. Ronald F. Davoli, President
Wharton-Smith, Inc.
750 Monroe Road
Sanford, FL 32771

RE: Bid No: 17-63; Players Club Water Reclamation Facility
– Master Contract No: 17-MCS-WHA-08742

Dear Mr. Davoli:

Attached please find the following:

1. A fully executed original copy of the Standard Fixed Price Agreement between Owner and Contractor for your files.
2. Public Construction Bond form that is to be obtained from your bonding company and recorded at the St. Johns County Clerk of Courts, in St. Augustine, FL 32084. Please forward an original certified copy of the recorded bond, at my attention, to the address shown below as soon as possible upon receipt of this letter.

Upon receipt of the original certified copy of the recorded bond, a Pre-Construction meeting will be scheduled and an official Notice to Proceed will be issued. Please be advised that any work implemented or contractual commitments made by Wharton-Smith, Inc. prior to receipt of an official Notice to Proceed is done at the contractor's own risk.

3. Form 1550 – Request for Payment with the following Instructions:
 - a. Submit all requests for payment on the attached Form 1550 with all applicable documents attached to each copy (i.e. Schedule of Values). Any appropriate back-up can be attached but failure to submit requests on this form may delay payment. (An electronic format (Excel) of this form is available upon request)
 - b. When submitting for payment, prepare three (3) originals of Form 1550, with invoices, and backup documentation, and submit to: Scott Trigg, Project Manager, SJC Engineering Dept, 1205 State Road 16, St. Augustine, FL 32084.

Please feel free to call me at (904) 209-0154 should you have any questions regarding any of the above.

Sincerely,
St. Johns County
Purchasing Department

A handwritten signature in black ink, appearing to read "Leigh A. Daniels".

Leigh A. Daniels, CPPB
Procurement Supervisor
(904) 209-0154 – Direct
(904) 209-0155 – Fax

CC: SJC Minutes & Records
SJC Purchasing Bid No: 17-63 Master Contract File