

RESOLUTION NO. 2018 - 49

**A RESOLUTION BY THE BOARD OF COUNTY COMMISSIONERS OF ST. JOHNS COUNTY, FLORIDA, AUTHORIZING THE COUNTY ADMINISTRATOR, OR DESIGNEE, TO AWARD BID NO. 18-32 AND TO EXECUTE AN AGREEMENT FOR NORTHWEST WTP 20 INCH WATER MAIN EXTENSION**

**RECITALS**

**WHEREAS**, the County desires to enter into a contract with G&H Underground Construction, Inc. to complete the Northwest WTP 20 Inch Water Main Extension; and

**WHEREAS**, The Contractor shall furnish all labor, equipment and material necessary for the construction of a 1020 LF 20" DI PC250 water main extension from the entrance road of the Northwest WTP to International Golf Pkwy within the future right-of-way (ROW) of CR2209 per the plans provided in the bid documents; and

**WHEREAS**, through the County's formal Bid process, G&H Underground Construction, Inc. was the lowest, responsive, responsible bidder to enter into a contract with the County to perform the work referenced above; and;

**WHEREAS**, the County has reviewed the terms, provisions, conditions and requirements of the proposed contract (attached hereto, an incorporated herein) and finds that entering into contracts to complete the work services serves a public purpose.

**WHEREAS**, the contract will be in substantial conformance with the attached draft contract.

**NOW, THEREFORE BE IT RESOLVED BY THE BOARD OF COUNTY COMMISSIONERS OF ST. JOHNS COUNTY, FLORIDA**, as follows:

Section 1. The above Recitals are incorporated by reference into the body of this Resolution and such Recitals are adopted as finds of fact.

Section 2. The County Administrator, or designee, is hereby authorized to award Bid 18-32 to G&H Underground Construction, Inc. and to execute a contract for the services set forth therein.

Section 3. Upon Board approval, the County Administrator, or designee, is authorized to execute an agreement in substantially the same form and format as the attached draft on behalf of the County to provide the scope of services, as specifically provided in Bid 18-32.

Section 4. To the extent that there are typographical and/or administrative errors that do not change the tone, tenor, or concept of this Resolution, then this Resolution may be revised without subsequent approval by the Board of County Commissioners.

**PASSED AND ADOPTED** by the Board of County Commissioners of St. Johns County, Florida, this 20 day of February, 2018.

**BOARD OF COUNTY COMMISSIONERS OF  
ST. JOHNS COUNTY, FLORIDA**

By: Henry Dean  
Henry Dean, Chair

ATTEST, Hunter S. Conrad, Clerk  
By: Ram Halterman  
Deputy Clerk

RENDITION DATE 2/21/18





**STANDARD AGREEMENT  
BETWEEN  
OWNER AND CONTRACTOR  
(1992 EDITION, REVISED 12/18/13)**

This Contract Agreement (“Agreement”) is made as of \_\_\_\_\_, 2018 by and between **ST. JOHNS COUNTY, FL** (“Owner”), a political subdivision of the State of Florida, whose principal offices are located at 500 San Sebastian View, St. Augustine, FL 32084, and **G&H Underground Construction, Inc.** (“Contractor”), with offices located at: 2200 N Ponce De Leon Blvd, Suite 11, St. Augustine, FL 32084, Phone: (904) 829-8199, Fax: (904) 810-0531, and E-mail: ghunderground@bellsouth.net, under seal for Construction of **BID NO: 18-32, Northwest WTP 20 Inch Water Main Extension**, hereinafter referred to as the “Project”.

The Owner and the Contractor hereby agree as follows:

**ARTICLE I  
THE CONTRACT AND THE CONTRACT DOCUMENTS**

**1.1 The Contract**

1.1.1 The Contract between the Owner and the Contractor, of which this Agreement is a part, consists of the Contract Documents. It shall be effective on the date this Agreement is executed by the last party to execute it.

**1.2 The Contract Documents**

1.2.1 The Contract Documents consist of this Agreement, the Bid Documents and Bid Forms, Specifications, all Change Orders and Field Orders issued hereafter and executed by the parties and the Engineers, any other amendments hereto executed by the parties hereafter, together with the following: Bid Documents, Addendum 1, Addendum 2, Addendum 3, Bonds and Insurance.

Documents not enumerated in this Paragraph 1.2.1 are not Contract Documents and do not form part of this Agreement.

**1.3 Entire Agreement**

1.3.1 The Contract, together with the Contractor’s Public Construction Bond for the Project, constitutes the entire and exclusive agreement between the Owner and the Contractor with reference to this Project. Specifically, but without limitation, this Agreement supersedes any Bid Documents not listed among the Contract Documents described above and all prior written or oral communications, representations and negotiations, if any, between the Owner and Contractor.

**1.4 No Privity with Others**

1.4.1 Nothing contained in this Agreement shall create, or be interpreted to create, privity or any other contractual agreement between the Owner and any person or entity other than the Contractor.

**1.5 Intent and Interpretation**

1.5.1 The intent of this Agreement is to require complete, correct and timely execution of the Work. Any work that may be required implied or inferred by the Contract Documents, or any one or more of them, as necessary to produce the intended result shall be provided by the Contractor for the Contract Price.

1.5.2 The Contract is intended to be an integral whole and shall be interpreted as internally consistent. What is required by any one Contract Document shall be considered as required by the Contract.

1.5.3 When a word, term or phrase is used in this Agreement, it shall be interpreted or construed, first, as defined herein; second, if not defined, according to its generally accepted meaning in the construction industry; and third, if there is no generally accepted meaning in the construction industry, according to its common and customary usage.

1.5.4 The words “include,” “includes” or “including,” as used in this Agreement, shall be deemed to be followed by the phrase “without limitation.”

1.5.5 The specification herein of any act, failure, refusal, omission, event, occurrence, or condition as constituting a

material breach of this Agreement shall not imply that any other, non-specified act, failure, refusal, omission, event, occurrence, or condition shall be deemed not to constitute a material breach of this Agreement.

1.5.6 Words or terms used as nouns in this Agreement shall be inclusive of their singular and plural forms, unless the context of their usage clearly requires a contrary meaning.

1.5.7 The Contractor shall have a continuing duty to read, carefully study and compare each of the Contract Documents, the Shop Drawings and the Product Data and shall give written notice to the Engineer and the Owner of any inconsistency, ambiguity, error or omission which the Contractor may discover with respect to these documents before proceeding with the affected Work. The issuance, or the express or implied approval by the Owner or the Engineer of the Contract Documents, Shop Drawings, or Product Data shall not relieve any such approval by evidence of the Contractor's compliance with the Contract. The Owner has requested the Engineer to only prepare documents for the Project, including the Drawings and Specifications for the Project, which are accurate, adequate, consistent, coordinated, and sufficient for construction. **HOWEVER, THE OWNER MAKES NO REPRESENTATION OR WARRANTY OF ANY NATURE WHATSOEVER TO THE CONTRACTOR CONCERNING SUCH DOCUMENTS.** By the execution hereof, the Contractor acknowledges and represents that it has received, reviewed and carefully examined such documents, has found them to be complete, accurate, adequate, consistent, coordinated and sufficient for construction, and that the Contractor has not, does not, and shall not rely upon any representation or warranties by the Owner concerning such documents as no such representation or warranties have been or are hereby made.

1.5.8 As between numbers and scaled measurements on the Drawings and in the Design, the numbers shall govern; as between larger scale and smaller scale drawings, the larger scale shall govern.

1.5.9 Neither the organization of any of the Contract Documents into divisions, sections, paragraphs, articles, (or other categories), nor the organization or arrangement of the Design, shall control the Contractor in dividing the Work or in establishing the extent or Scope of Work to be performed by Subcontractors.

## **1.6 Ownership of Contract Documents**

1.6.1 The Contract Documents, and each of them, shall remain the property of the Owner. The Contractor shall have the right to keep one record set of the Contract Documents upon completion of the Project; provided, however, that in no event shall Contractor use, or permit to be used, any or all of such Contract Documents on other projects without Owner's prior written authorization..

## **ARTICLE II THE WORK**

### **2.1 Scope of Work**

The Contractor shall perform all of the Work required, implied, or reasonably inferable from, this Agreement.

2.1.1 The term "Work" shall mean whatever is done by or required of the Contractor to perform and complete its duties under this Agreement, including the following: construction of the whole or a designated part of the Project in the manner set forth in the Contract Documents; furnishing of any required Surety Bonds and insurance; and the provision or furnishing of labor, supervision, services, materials, supplies, equipment, fixtures, appliances, facilities, tools, transportation, storage, power, permits and licenses required of the Contractor, fuel, heat, light, cooling and all other utilities as required by this Agreement. The Work to be performed by the Contractor is generally described as follows:

The Contractor shall furnish all labor, equipment and material necessary for the construction of a 1020 LF 20" DI PC250 water main extension from the entrance road of the Northwest WTP to International Golf Pkwy within the future right-of-way (ROW) of CR2209 per the plans provided. The project shall be constructed according to the St. Johns County Utility Department (SJCUD) Manual of Water, Wastewater, and Reuse Design Standards and Specifications, Latest Edition, which can be located at: <http://www.sjcf.us/Utilities/media/DevGroup/WaterStds&SpecsManual.pdf>:

All work shall be performed in accordance with the plans and specifications under Bid No. 18-32.

## ARTICLE III CONTRACT TIME

### 3.1 Time and Liquidated Damages

3.1.1 The Contractor shall commence the Work within ten (10) days upon receipt of the Notice to Proceed and shall Substantially Complete all Work within Sixty (60) consecutive calendar days. Final Completion shall be reached by or before Thirty (30) consecutive calendar days after Substantial Completion.

The number of calendar days from the date on which the Work is permitted to proceed, through the date set forth for Final Completion, shall constitute the "Contract Time."

3.1.2 The Contractor shall pay the Owner the sum of \$958.00 per day for each and every calendar day of unexcused delay in achieving Substantial Completion beyond the date set forth herein for Substantial Completion of the Work. Any sum's due and payable hereunder by the Contractor shall be payable, not as a penalty, but as liquidated damages representing an estimate of delay damages likely to be sustained by the Owner, estimated at or before the time of executing this Agreement. When the Owner reasonably believes that Substantial Completion shall be inexcusably delayed the Owner shall be entitled, but not required, to withhold from any amounts otherwise due the Contractor an amount then believed by the Owner to be adequate to recover liquidated damages applicable to such delays. If and when the Contractor overcomes the delay in achieving Substantial Completion, or any part thereof, for which the Owner has withheld payment, the Owner shall promptly release to the Contractor those funds withheld, but no longer applicable, as liquidated damages.

### 3.2 Substantial Completion

3.2.1 "Substantial Completion" shall mean that stage in the progression of the Work when the Work is sufficiently complete in accordance with this Agreement that the Owner can enjoy beneficial use or occupancy of the Work and can utilize the Work for its intended purpose.

### 3.3 Time is of the Essence

3.3.1 All limitations of time set forth in the Contract Documents are of the essence of this Agreement.

## ARTICLE IV CONTRACT PRICE

### 4.1 The Contract Price

4.1.1 The Owner shall pay, and the Contractor shall accept, as full and complete payment for all the Work required herein a total Lump Sum price of Two Hundred Twenty-two Thousand Twenty dollars (\$222,020.00).

The sum set forth in the Paragraph 4.1 shall constitute the Contract Price, which shall not be modified except by Change Order as provided in this Agreement.

## ARTICLE V PAYMENT OF THE CONTRACT PRICE

### 5.1 Schedule of Values

5.1.1 Within ten (10) calendar days of the effective date hereof, the Contractor shall submit to the Owner and to the Project Director a Schedule of Values allocating the Contract Price to the various portions of the Work. The Contractor's Schedule of Values shall be prepared in such form, with such detail, and supported by such data as the Project Director or the Owner may require to substantiate its accuracy. The Contractor shall not imbalance its Schedule of Values nor artificially inflate any element thereof. The violation of this provision by the Contractor shall constitute a material breach of this Agreement. The Schedule of Values shall be used only as a basis for the Contractor's Applications for Payment and shall only constitute such basis after it has been agreed upon in writing by the Project Director and the Owner. The Owner may terminate this Agreement without liability of any kind if the Schedule of Values is not agreed upon within fifteen (15) calendar days of the effective date hereof.

### 5.2 Payment Procedure

5.2.1 The Owner shall pay the Contract Price to the Contractor as provided below.

5.2.2 Progress Payments - On or before the fifteen (15) day of each month after commencement of the Work, the Contractor shall submit an Application for Payment for the period ending the thirtieth (30th) day of the previous month to the Project Director in such form and manner, and with such supporting data and content, as the Project Director may require. Therein, the Contractor may request payment based upon the amount of work done or completed. All partial estimates and payments shall be subject to correction when submitted. Based upon the Contractor's Applications for Payment submitted to the Project Director and upon Certificates for Payment subsequently issued to the Owner by the Project Director, payments will be made in accordance with the Local Government Prompt Payment Act.

5.2.3 The amount of such payments shall be the total value of the Work done to the date of the estimate, based upon the quantities and the Contract unit and/or lump sum prices, less an amount retained and less payments previously made. The amount retained shall be determined in accordance with Section 255.078 of the Florida Statutes:

(a) Owner may withhold from each progress payment made to the Contractor an amount not to exceed ten (10) percent of the payment as retainage until fifty (50) percent completion of the Work.

(b) After fifty (50) percent completion of the Work is purchased pursuant to this Agreement, Owner will reduce to five (5) percent the amount of retainage withheld from each subsequent progress payment made to the Contractor. The term "fifty (50) percent completion" as used in this provision means the point at which Owner has expensed fifty (50) percent of the total cost of the Work purchased as provided herein, together with all costs associated with existing change orders and other additions or modifications to the Work described herein.

(c) After fifty (50) percent completion of the Work is purchased pursuant to this Agreement, the Contractor may present to the Owner a payment request for up one-half of the retainage held by the Owner. The Owner shall make prompt payment to the Contractor, unless in accordance with Section 255.078(6) of the Florida Statutes, such funds are the subject of a good faith dispute, claim or demand by the Owner or the Contractor.

5.2.4 Each Application for Payment shall be signed by the Contractor and shall constitute the Contractor's representation that the Work has progressed to the level for which payment is requested that the Work has been properly installed or performed in full accordance with this Agreement, and that the Contractor knows of no reason why payment should not be made as requested. Thereafter, the Project Director and Engineer shall review the Application for Payment and may also review the Work at the project site or elsewhere to determine whether the quantity and quality of the Work is as represented in the Application for Payment and is as required by this Agreement. The Project Director shall determine and certify to the Owner the amount properly owing to the Contractor. The Owner shall make partial payments on accounts of the Contract Price within thirty (30) days following the Project Director's receipt of each Application for Payment. The amount of each partial payment shall be the amount certified for payment by the Project Director less such amounts, if any, otherwise owing by the Contractor to the Owner or which the Owner shall have the right to withhold as authorized by this Agreement. The Project Director's certification of the Contractor's Application for Payment shall not preclude the Owner from the exercise of any of its rights as set forth in Paragraph 5.3 herein below.

5.2.5 The Contractor warrants that title to all Work covered by an Application shall pass to the Owner no later than time of payment. The Contractor further warrants that upon submittal of an Application for Payment, all Work for which payments have been received from the Owner shall be free and clear of liens, claims, security interest or other encumbrances in favor of the Contractor or any other person or entity whatsoever.

5.2.6 The Contractor shall promptly pay each Subcontractor out of the amount paid to the Contractor on account of such Subcontractor's Work, the amount to which such Subcontractor is entitled. In the event the Owner becomes informed that the Contractor has not paid a Subcontractor as herein provided, the Owner shall have the right, but not the duty, to issue future checks in payment to the Contractor of amounts otherwise due hereunder naming the Contractor and such Subcontractor as joint hereunder naming the Contractor and such Subcontractor as joint payees. Such joint check procedure, if employed by the Owner, shall create no rights in favor of any person or entity beyond the right of the named payees to payment of the check and shall not be deemed to commit the Owner to repeat the procedure in the future.

5.2.7 No progress payment, nor any use or occupancy of the Project by the Owner, shall be interpreted to constitute an acceptance of any Work not in strict accordance with this Agreement.

### **5.3 Withheld Payment**

5.3.1 Owner may decline to make payment, may withhold funds and, if necessary, may demand the return of some or

all of the amounts previously paid to the Contractor, to protect the Owner from loss because of:

- a) Defective Work not remedied by the Contractor and, in the opinion of the Owner, not likely to be remedied by the Contractor;
- b) claims of third parties against the Owner or the Owner's property;
- c) Failure by the Contractor to pay Subcontractors or others in a prompt and proper fashion;
- d) Evidence that the balance of the Work cannot be completed in accordance with the Contract for unpaid balance of the Contract Price;
- e) Evidence that the Work shall not be completed in the time required for Substantial or Final Completion;
- f) Persistent failure to carry out the Work in accordance with the Contract;
- g) Damage to the Owner or a third party to whom the Owner is, or may be, liable.

In the event that the Owner makes written demand upon the Contractor for amounts previously paid by the Owner as contemplated in this Subparagraph 5.3.1, the Contractor shall promptly comply with such demand.

#### **5.4 Unexcused Failure to Pay**

5.4.1 If within ten (10) days after the date established herein for payment to the Contractor by the Owner, the Owner, without cause or basis hereunder, fails to pay the Contractor any amount due and payable to the Contractor, then the Contractor may after seven (7) additional days, written notice to the Owner and the Project Director, and without prejudice to any other available rights or remedies it may have, stop the Work until payment of those amounts due from the Owner have been received. Any payment not made within ten (10) days after the date due shall bear interest at the rate of 12 percent (12%) per annum.

#### **5.5 Substantial Completion**

5.5.1 When the Contractor believes the Work is Substantially Complete, the Contractor shall submit to the Project Director a list of items to be completed or corrected. When the Project Director on the basis of an inspection determines that the Work is in fact Substantially Complete, he shall prepare a Certificate of Substantial Completion which shall establish the date of Substantial Completion, shall state the responsibilities of the Owner and the Contractor for Project security, maintenance, heat, utilities, damage to the Work, and insurance, and shall fix the time within which the Contractor shall complete the items listed therein. Guarantees required by the Contract shall commence on the date of Substantial Completion of the Work. The Certificate of Substantial Completion shall be submitted to the Owner and the Contractor for their written acceptance of the responsibilities assigned to them in such certificate.

Until Final Completion and acceptance of the Work by the Owner, the Owner shall pay the Contractor an amount equal to ninety percent (90%) of the Contract price. Ten Percent (10%) of the Contract Price shall be retained until Final Completion, acceptance of the Work by the Owner and Final Payment to the Contractor.

#### **5.6 Final Completion and Final Payment**

5.6.1 When all the Work is finally complete and the Contractor is ready for a Final Inspection, it shall notify the Owner and the Project Director thereof in writing. Thereupon, the Project Director shall make Final Inspection of the Work and, if the Work is complete in full accordance with this Agreement and this Agreement has been fully performed, the Project Director shall promptly issue a Final Certificate for Payment and if required to repeat its Final Inspection of the Work, the Contractor shall bear the cost of such repetition of the Work, the Contractor shall bear the cost of such repeat Final Inspection(s) which cost may be deducted by the Owner and all other Authorities having jurisdiction under Florida Laws or regulations.

5.6.1.1 If the Contractor fails to achieve Final Completion within the time fixed therefore by the Engineer in its Certificate of Substantial Completion, the Contractor shall pay the Owner liquidated damages at the sum shown in Paragraph 3.1.2. per day for each and every calendar day of unexcused delay in achieving Final Completion beyond the date set forth herein for Final Completion of the Work. Any sum's due and payable hereunder by the Contractor shall be payable, not as penalty, but as liquidated damages representing an estimate of delay damages likely to be sustained by the Owner, estimated at or before the time of executing the Contract. When the Owner reasonably believes that Final Completion shall be inexcusably delayed, the Owner shall be entitled, but not required, to withhold from any amounts otherwise due the Contractor an amount then believed by the Owner to be adequate to recover liquidated damages applicable to such delays. If and when the Contractor overcomes the delay in achieving Final Completion, or any part thereof, for which the Owner has withheld payment, the Owner shall promptly release to the Contractor those funds

withheld, but no longer applicable, as liquidated damages.

5.6.2 The Contractor shall not be entitled to Final Payment unless and until it submits to the Project Director its affidavit that all payrolls, invoices for materials and equipment, and other liabilities connected with the Work for which the Owner, or the Owner's property might be responsible, have been fully paid or otherwise satisfied; releases and waivers of claims and lien from all Subcontractors of the Contractor and of any and all other parties required by the Project Director or the Owner; consent of Surety, if any, to Final Payment. If any third party fails or refuses to provide a release of claim or waiver of a lien as required by Owner the Contractor shall furnish a bond satisfactory to the Owner to discharge any such lien or indemnify the Owner from liability.

5.6.3 The Owner shall make Final Payment of all sums, due the Contractor within thirty (30) days of the Project Director's execution of a Final Certificate for Payment.

5.6.4 Acceptance of Final Payment shall constitute a waiver of all claims against the Owner by the Contractor except for those claims previously made in writing against the Owner by the Contractor, pending at the time of Final Payment, and identified in writing by the Contractor as unsettled at the time of its request for Final Payment.

## **ARTICLE VI THE OWNER**

### **6.1 Information, Services and Things Required from Owner**

6.1.1 The Owner shall furnish to the Contractor, at the time of executing this Agreement, any and all written and tangible material in its possession concerning conditions below ground at the site of the Project. Such written and tangible material is furnished to the Contractor only in order to make complete disclosure of such material and for no other purpose. By furnishing such material, the Owner does not represent, warrant, or guarantee its accuracy either in whole, in part, implicitly, or at all, and shall have no liability therefore. The Owner shall also furnish surveys, legal limitations and utility locations (if known), and a legal description of the Project site. Copies may be provided instead of originals.

6.1.2 Excluding permits and fees normally the responsibility of the Contractor, the Owner shall obtain all approvals, easements, and the like required for construction.

6.1.3 The Owner shall furnish the Contractor, free of charge, 5 copies of the Contract Documents for execution of the Work. The Contractor shall be charged, and shall pay the Owner \$25.00 per additional set of Contract Documents which it may require.

### **6.2 Right to Stop Work**

6.2.1 If the Contractor persistently fails or refuses to perform the Work in accordance with this Agreement, the Owner may order the Contractor to stop the Work, or any described portion thereof, until the cause for stoppage has been corrected, no longer exists, or the Owner orders that Work be resumed. In such event, the Contractor shall immediately obey such order.

### **6.3 Owner's Right to Perform Work**

6.3.1 If the Contractor's Work is stopped by the Owner under Paragraph 6.2, and the Contractor fails within seven (7) days of such stoppage to provide adequate assurance to the Owner that the cause of such stoppage shall be eliminated or corrected, the Owner may, without prejudice to any other rights or remedies the Owner may have against the Contractor, proceed to carry out the subject Work.

In such a situation, an appropriate Change Order shall be issued deducting from the Contract Price the cost of correcting the subject deficiencies, and compensation for the Owner's additional services and expenses necessitated thereby, if any. If the unpaid portion of the Contract Price is insufficient to cover the amount due the Owner, the Contractor shall pay the difference to the Owner.

## **ARTICLE VII THE CONTRACTOR**

7.1 The Contractor is again reminded of its continuing duty set forth in Subparagraph 1.5.7. The Contractor shall

perform no part of the Work at any time without adequate Contract Documents or, as appropriate, approved Shop Drawings, Product Data or Samples for such portion of the Work. If the Contractor performs any of the Work where Contractor knows or should know such work involves a recognized error, inconsistency or omission in the Contract Documents without such notice to the Project Director and the Owner, the Contractor shall bear responsibility for such performance and shall bear the cost of correction.

**7.2** The Contractor shall perform the Work strictly in accordance with this Agreement.

**7.3** The Contractor shall supervise and direct the Work using the Contractor's best skill, effort and attention. The Contractor shall be responsible to the Owner for any and all acts or omissions of the Contractor, its employees and other engaged in the Work on behalf of the Contractor.

**7.4. Warranty**

**7.4.1** The Contractor warrants to the Owner that all labor furnished to progress the Work under this Agreement shall be competent to perform the tasks undertaken, that the product of such labor shall yield only first-class results, that materials and equipment furnished shall be of good quality, free from faults and defects and in strict conformance with this Agreement. This warranty shall survive termination of this Agreement and shall not be affected by Final Payment hereunder. All Work not conforming to these requirements may be considered defective.

**7.5** Contractor shall obtain and pay for all permits, fees and licenses necessary and ordinary for the Work. The Contractor shall comply with all lawful requirements applicable to the Work and shall give and maintain any and all notices required by applicable law pertaining to the Work.

**7.6 Supervision**

**7.6.1** The Contractor shall employ and maintain at the Project site only competent supervisory personnel. Absent written instruction from the Contractor to the contrary, the superintendent shall be deemed the Contractor's authorized representative at the site and shall be authorized to receive and accept any and all communications from the Owner or Assignees.

**7.6.2** Key supervisory personnel assigned by the Contractor to this Project are as follows:

Name	Function.
_____	_____
_____	_____
_____	_____

So long as the individuals named above remain actively employed or retained by the Contractor, they shall perform the functions indicated next to their names unless the Owner agrees to the contrary in writing. In the event one or more individuals not listed above subsequently assume one or more of those functions listed above, the Contractor shall be bound by the provisions of this Subparagraph 7.6.2 as though such individuals have been listed above.

**7.7** The Contractor, prior to commencing the Work, shall submit to the Project Director for his information, the Contractor's schedule for completing the Work. The Contractor's schedule shall be revised no less frequently than monthly (unless the parties otherwise agree in writing) and shall be revised to reflect conditions encountered from time to time and shall be related to the entire Project. Each sum revision shall be furnished to the Project Director. Failure by the Contractor to strictly comply with the provisions of this Paragraph 7.7 shall constitute a material breach of this Agreement.

**7.8** The Contractor shall continuously maintain at the site, for the benefit of the Project Director, one record copy of this Agreement marked to record on a current basis changes, selections and modifications made during construction. Additionally, the Contractor shall maintain at the site for the Project Director the approved Product Data, Samples and other similar required submittals. Upon Final Completion of the Work, all of these record documents shall be delivered to the Owner.



## **7.9 Product Data and Samples**

7.9.1 Product Data, Samples and other submittals from the Contractor do not constitute Contract Documents. Their purpose is merely to demonstrate the manner in which the Contractor intends to implement the Work in conformance with the information received from the Contract Documents. All Product Data, Samples and other submittals shall belong to the Owner and shall be delivered, or returned to Owner, as applicable, prior to Submittals shall belong to Owner and shall be delivered, or returned to Owner, as applicable, prior to Substantial Completion.

## **7.10 Cleaning the Site and the Project**

7.10.1 The Contractor shall keep the site reasonably clean during performance of the Work. Upon Final Completion of the Work, the Contractor shall clean the site and the Project and remove all waste, together with all of the Contractor's property therefrom.

## **7.11 Access to Work**

7.11.1 The Owner and the Project Director shall have access to the Work at all times from commencement of the Work through Final Completion. The Contractor shall take whatever steps necessary to provide access when requested.

## **7.12 Indemnity**

7.12.1 To the fullest extent permitted by law, the Contractor shall indemnify and hold harmless the Owner, employees and officials from, and against, any, and all, administrative/legal/equitable liability, claims, damages, losses and expenses, including attorneys' fees, arising out of or resulting from performance of the work, noted in either the Scope of Work, or the Contract Documents, that are referenced and considered a part of this Agreement. It is specifically noted that such liability, claims, damages, loss or expense includes any of those referenced instances attributable to bodily injury, sickness, disease, or death, or to injury to, or destruction of, personal and/or real property, including the loss of use resulting therefrom or incident to, connected with, associated with or growing out of direct and/or indirect negligent or intentional acts or omissions by the Contractor, a Subcontractor, or anyone directly, or indirectly employed by them, or anyone for whose acts the Contractor or Subcontractor may be liable, regardless of whether or not such liability, claim, damage, loss or expense is caused in part by a party indemnified hereunder.

7.12.2 In claims against any person or entity indemnified under this Paragraph 7.12 by an employee of the Contractor, a Subcontractor, any one directly or indirectly employed by them or anyone for whose acts they may be liable, the indemnification obligation under this Paragraph 7.12 shall not be limited by a limitation on amount or type of damages, compensation or benefits payable by or for the Contractor or a Subcontractor under workers' compensation acts, disability benefits acts or other employee benefit acts.

## **7.13 Safety**

7.13.1 The Contractor shall be responsible for supervising all safety precautions, including initiating and maintaining such programs in connection with the performance of the Contract and for adequate maintenance of traffic.

7.13.2 The Contractor shall designate a member of the on-site construction team whose duty shall be the prevention of accidents. Unless notified otherwise in writing by the Contractor to the Owner and the Engineer, this person shall be the Contractor's Superintendent.

## **ARTICLE VIII CONTRACT ADMINISTRATION**

### **8.1 Project Director**

8.1.1 The Project Director, unless otherwise directed by the Owner shall perform those duties and discharge those responsibilities allocated to the Project Director as set forth in this Agreement. The Project Director shall be the Owner's representative from the effective date of this Agreement until Final Payment has been made. The Project Director shall be authorized to act on behalf of the Owner only to the extent provided in this Agreement.

8.1.2 The Owner and the Contractor shall communicate with each other in the first instance through the Project Director.

8.1.3 The Project Director shall be the initial interpreter of the requirements of the drawings and specifications and the judge of the performance there under by the Contractor. The Project Director shall render written or graphic interpretations necessary for the proper execution or progress of the Work with reasonable promptness on request of the

Contractor.

8.1.4 The Project Director shall review the Contractor's Applications for Payment and shall certify to the Owner for payment to the Contractor, those amounts then due to the Contractor as provided in this Agreement.

8.1.5 The Project Director shall have authority to reject Work, which is defective or does not conform to the requirements of this Agreement. If the Project Director deems it necessary or advisable, the Project Director shall authority to require additional inspection or testing of the Work for compliance with Contract requirements at Contractor's expense.

8.1.6 The Project Director shall review and approve, or take other appropriate action as necessary, concerning the Contractor's submittals including Product Data and Samples. Such review, approval or other action shall be for the sole purpose of determining conformance with the design concept and information given through the Contract Documents.

8.1.7 The Project Director shall prepare Change Orders and may authorize minor changes in the Work by field order as provided elsewhere herein.

8.1.8 The Project Director shall, upon written request from the Contractor, conduct inspections to determine the date of Substantial Completion and the date of Final Completion, shall receive and forward to the Owner for the Owner's review and records, written warranties and related documents required by this Agreement and shall issue a Final Certificate for Payment upon compliance with the requirements of this Agreement.

8.1.9 The Project Director's decision in matters relating to aesthetic effect shall be final if consistent with the intent of this Agreement.

## **8.2 Claims by the Contractor**

8.2.1 All Contractor claims shall be initiated by written notice and claim to the Project Director. Such written notice and claims must be furnished within seven (7) days after occurrence of the event, or the first appearance of the condition, giving rise to the claim.

8.2.2 Pending final resolution of any claim of the Contractor, the Contractor shall diligently proceed with performance of this Agreement and the Owner shall continue to make payments to the Contractor in accordance with this Agreement. The resolution of any claim under this Paragraph 8.2 shall be reflected by a Change Order executed by the Project Director and the Contractor.

8.2.3 Claims for Concealed and Unknown Conditions - Should concealed and unknown conditions encountered in the performance of the Work (a) below the surface of the ground or (b) in an existing structure be at variance with the conditions indicated by this Agreement, or should unknown conditions of an usual nature differing materially from those ordinarily encountered in the area and generally recognized as inherent in Work of the character provided for in this Agreement, be encountered, wherein the Contract Documents or Standard Construction industry practices have not placed the responsibility of discovering such concealed and unknown conditions upon the Contractor prior to the Contractor submitting his Bid for the Work, the Contract Price shall be equitably adjusted by Change Order upon the written notice and claim by either party made within seven (7) days after the first observance of the condition. As a condition precedent to the Owner having any liability to the Contractor for concealed or unknown conditions, the Contract must give the Project Director written notice of, and an opportunity to observe, the condition prior to disturbing it. The failure by the Contractor to make the written notice and claim as provided in this Subparagraph shall constitute a waiver by the Contractor of any claim arising out of or relating to such concealed or unknown condition.

8.2.4 Claims for Additional Costs - If the Contractor wishes to make a claim for an increase in the Contract Price, as a condition precedent to any liability of the Owner therefore, the Contractor shall give the Project Director written notice of such claim within seven (7) days after the occurrence of the event, or the first appearance of the condition, giving rise to such claim. Such notice shall be given by the Contractor before proceeding to execute any additional or changed Work. The failure by the Contractor to give such notice prior to executing the Work shall constitute a waiver of any claim for additional compensation.

8.2.4.1 In connection with any claim by the Contractor against the Owner for compensation in excess of the Contract Price, any liability of the Owner for the Contractor's costs shall be strictly limited to direct costs incurred by the Contractor and shall in no event include indirect costs or consequential damages of the Contractor.

The Owner shall not be liable to the Contractor for claims of third parties, including Subcontractors, unless and until liability of the Contractor has been established therefore in a court of competent jurisdiction.

8.2.5 Claims for Additional Time - If the Contractor is delayed in progressing any task which at the time of the delay is then critical or which during the delay becomes critical, as the sole result of any act or neglect to act by the Owner or someone acting in the Owner's behalf, or by changes ordered in the Work, unusual delay in transportation, unusually adverse weather conditions not reasonably anticipated, fire or any causes beyond the Contractor's control, then the date for achieving Substantial Completion of the Work shall be extended upon the written notice and claim of the Contractor to the Project Director, for such reasonable time as the Project Director may determine.

Any notice and claims for an extension of time by the Contractor shall be made not more than seven (7) days after the occurrence of the event or the first appearance of the condition giving the rise to the claim and shall set forth in detail the Contractor's basis for requiring additional time in which to complete the Project. In the event the delay to the Contractor is continuing one, only one notice and claim for additional time shall be necessary. If the Contractor fails to make such claim for an extension shall be waived. This paragraph shall not be deemed to waive any damages for delay that are covered by insurance.

8.2.5.1 Delays and Extensions of Time - An extension of Contract Time shall not be given due to weather conditions unless such weather conditions more severe than average have caused a delay. In requesting extension of time for weather conditions; Contractor shall present complete records and such requests shall document how weather conditions delayed progress of Work.

### **8.3 Field Orders**

8.3.1 The Project Director shall have authority to order minor changes in the Work not involving a change in the Contract Price or in Contract Time and not inconsistent with the intent of the Contract. Such changes shall be effected by field order and shall be binding upon the Contractor. The Contractor shall carry out such field orders promptly.

## **ARTICLE IX SUBCONTRACTORS**

### **9.1 Definition**

9.1.1 A Subcontractor is an entity, which has a direct Contract with the Contractor to perform a portion of the Work.

### **9.2 Award of Subcontracts**

9.2.1 Upon execution of the Contract, the Contractor shall furnish the Project Director, in writing, the names of persons or entities proposed by the Contractor to act as a Subcontractor on the Project. The Project Director shall promptly reply to the Contractor, in writing, stating any objections the Project Director may have to such proposed Subcontractor. The Contractor shall not enter into a Subcontract with a proposed Subcontractor with reference to whom the Project Director has made a timely objection.

9.2.2 All subcontracts shall afford the Contractor rights against the Subcontractor, which correspond to those rights afforded to the Owner by Subparagraph 12.2.1 below.

## **ARTICLE X CHANGES IN THE WORK**

### **10.1 Changes Permitted**

10.1.1 Changes in the Work within the general scope of this Agreement, consisting of additions, deletions, revisions, or any combination thereof, may be ordered without invalidating this Agreement, by Change Order or by Field Order.

10.1.2 Changes in the Work shall be performed under applicable provisions of this Agreement and the Contractor shall proceed promptly with such changes.

### **10.2 Change Order Defined**

10.2.1 Change Order shall mean a written order to the Contractor executed by the Project Director, issued after execution of this Agreement, authorizing and directing a change in the Work or an adjustment in the Contract Price or the Contract

Time, or any combination thereof. Only the Change Order may change the Contract Price and the Contract Time.

### **10.3 Changes in the Contract Price**

10.3.1 Any change in the Contract Price resulting from a Change Order shall be determined as follows: (a) by mutual agreement between the Owner and the Contractor as evidenced by (1) the change in the Contract Price being set forth in the Change Order, (2) such change in the Contract Price, together with any conditions or requirements related thereto, being initiated by both parties and (3) the Contractor's execution of the Change Order, or (b) if no mutual agreement occurs between the Owner and the Contractor, then, as provided in Subparagraph 10.3.2 below.

10.3.2 If no mutual agreement occurs between the Owner and the Contractor as contemplated in Subparagraph 10.3.1 above, the change in the Contract Price, if any, shall then be determined by the Project Director on the basis of the reasonable expenditures or savings of those performing, deleting or revising the Work attributable to the change, including, in the case of an increase or decrease in the Contract Price, a reasonable allowance for direct job site overhead and profit. In such case, the Contractor shall present, in such form and with such content as the Owner or the Project Director requires, an itemized accounting of such expenditures or savings shall be limited to the following: reasonable costs of materials, supplies, or equipment including delivery costs, reasonable costs of labor, including social security, old age and unemployment insurance, fringe benefits required by a pre-existing agreement or by custom, and workers' compensation insurance, reasonable costs of premiums for all Bonds and insurance, permit fees, and sales, use or other taxes related to the Work and paid by the Contractor, and reasonable costs of directly attributable to the change. In no event shall any expenditure or savings associated with the Contractor's home office or other non-jobsite overhead expenses be included in any change in the Contract Price. Pending final determination of reasonable expenditures or savings to the Owner, payments on account shall be made to the Contractor on the Owner's Certificate of Payment.

10.3.3 If Unit Prices are provided in the Contract, and if the quantities contemplated are so changed in proposed Change Order that application of such Unit Prices to the quantities of Work proposed shall cause substantial inequity to the Owner or to the Contractor, that applicable Unit Prices shall be equitable adjusted.

### **10.4 Minor Changes**

10.4.1 The Project Director shall have authority to order minor changes in the Work not involving a change in the Contract Price or an extension of the Contract Time and not inconsistent with the intent of this Agreement. Such minor changes shall be made by written Field Order, and shall be binding upon the Owner and the Contractor. The Contractor shall promptly carry out such written Field Orders.

### **10.5 Effect of Executed Change Order**

10.5.1 The execution of a Change Order by the Contractor shall constitute conclusive evidence of the Contractor's agreement to the ordered changes in the Work, this Agreement as thus amended, the Contract Price and the Contract Time. The Contractor, by executing the Change Order, waives and forever releases any claim against the Owner for additional time or compensation for matters relating to or arising out or resulting from the Work included within or affected by the executed Change Order.

### **10.6 Notice to Surety; Consent**

10.6.1 The Contractor shall notify and obtain the timely consent and approval of the Contractor's surety with reference to all Change Orders if such notice, consent or approval is required by the Contractor's surety or by law. The Contractor's warranty to the Owner that the surety has been notified of and consents to, such Change Order and the surety shall be conclusively deemed to have been notified of such Change Order and to have expressly consented thereto.

## **ARTICLE XI UNCOVERING AND CORRECTING WORK**

### **11.1 Uncovering Work**

11.1.1 If any of the Work is covered contrary to the Project Director's request or to any provision of this Agreement, it shall, if required by the Project Director, be uncovered for the Project Director's inspection and shall be properly replaced at the Contractor's expense without change in the Contract Time.

11.1.2 If any of the Work is covered in a manner not described in Subparagraph 11.1.1 above, it shall, if required by the by the Project Director or Owner, be uncovered for the Project Director's inspection. If such Work conforms strictly to

this Agreement, costs of uncovering and proper replacement shall by Change Order be charged to the Owner. If such Work does not strictly conform to this Agreement, the Contractor shall pay the costs of uncovering and proper replacement.

## **11.2 Correcting Work**

11.2.1 The Contractor shall immediately proceed to correct Work rejected by the Project Director as defective or failing to conform to this Agreement. The Contractor shall pay all costs and expenses associated with correcting such rejected Work, including any additional testing and inspections, and reimbursement to the Owner for the Project Director's services and expenses made necessary thereby.

11.2.2 If within one (1) year after Substantial Completion of the Work, if any of the Work is found to be defective or not in accordance with this Agreement, the Contractor shall correct it within seven (7) days at the Contractor's expense upon receipt of written notice from the Owner. This obligation shall survive Final Payment by the Owner and termination of this Agreement. With respect to Work first performed and completed after Substantial Completion, this one (1) year obligation to specifically correct defective and nonconforming Work shall be extended by the period of time which elapses between Substantial Completion and completion of the subject Work.

11.2.3 Nothing contained in this Paragraph 11.2 shall establish any period of limitation with respect to other obligations, which the Contractor has under this Agreement. Establishment of the one (1) year time period in Subparagraph 11.2.2 relates only to the duty of the Contractor to specifically correct the Work, and has no relationship to the time which the obligation to comply with the Contract Documents may be sought to be enforced.

## **11.3 Owner May Accept Defective or Nonconforming Work**

11.3.1 If the Owner chooses to accept defective or nonconforming Work, the Owner may do so. In such events, the Contract Price shall be reduced by the greater of (a) the reasonable cost of removing and correcting the defective or nonconforming Work, and (b) the difference between the fair market value of the Project had it not been constructed in such manner as to include defective or nonconforming Work. If the remaining portion of the unpaid Contract Price, if any, is insufficient to compensate the Owner for its acceptance or defective or nonconforming Work, the Contractor shall, upon written demand from the Owner, pay the Owner such remaining compensation for accepting defective or nonconforming Work.

## **ARTICLE XII CONTRACT TERMINATION**

### **12.1 Termination by the Contractor**

12.1.1 If the Work is stopped for a period of ninety (90) days by an order of any court or as a result of an act of the Government, through no fault of the Contractor or any person or entity working directly or indirectly for the Contractor, the Contractor may, upon ten (10) days written notice to the Owner, terminate performance under this Agreement and recover from the Owner payment for the actual reasonable expenditures of the Contractor (as limited in Subparagraph 10.3.2 above) for all Work executed and for materials, equipment, tools, construction equipment and machinery actually purchased or rented solely for the Work, less any salvage value of any such items.

12.1.2 If the Owner shall persistently or repeatedly fail to perform any material obligation to the Contractor for a period of fifteen (15) days after receiving written notice from the Contractor of its intent to terminate if such failure is not substantially corrected within fifteen (15) days, the Contractor may terminate performance under this Agreement by written notice to the Project Director. In such event, the Contractor shall be entitled to recover from the Owner as though the Owner had terminated the Contractor's performance under this Agreement for convenience pursuant to Subparagraph 12.2.1 hereunder.

### **12.2 Termination by the Owner**

#### **12.2.1 For Convenience**

12.2.1.1 The Owner may terminate this Agreement for convenience. In such instance, the Owner shall provide written notice of such termination to the Contractor specifying when termination shall become effective.

12.2.1.2 The Contractor shall incur no further obligations in connection with the Work and the Contractor shall stop Work when such termination becomes effective. The Contractor shall also terminate outstanding orders and subcontracts. The Contractor shall settle liabilities and claims arising out of the termination of subcontracts and orders. The Owner may

direct the Contractor to assign the Contractor's right, title and interest under terminated orders or subcontracts to the Owner or its designee.

12.2.1.3 The Contractor shall transfer title and deliver to the Owner such completed or partially completed Work and materials, equipment, parts, fixtures, information and Contract rights as the Contractor has.

12.2.1.4 (a) The Contractor shall submit a termination claim to the Project Director specifying the amounts due because of the termination for convenience together with costs, pricing or other data required by the Project Director. If the Contractor fails to file a termination claim within one (1) year from the effective date of termination, the Owner shall pay the Contractor, an amount derived in accordance with subparagraph (c) below.

(b) The Owner and the Contractor may agree to compensation, if any, due to the Contractor hereunder.

(c) Absent agreement to the amount due to the Contractor, the Owner shall pay the Contractor the following amounts;

(d) Contract prices for labor, materials, equipment, and other services accepted under this Agreement;

(e) Reasonable costs incurred in preparing to perform and in performing a portion of the Work prior to termination and not included in (d) or (e), and in terminating the Contractor's performance, plus a fair and reasonable allowance for overhead and profit thereon (such profit shall not include anticipated profit or consequential damages); provided, however, that if it appears that the Contractor would have not profited or would have sustained a loss if the entire Contract had been completed, no profit shall be allowed or included and the amount of compensation shall be reduced to reflect the anticipated rate of loss, if any;

(f) Reasonable costs of settling and paying claims arising out of the termination of Subcontracts or orders pursuant to Subparagraph 12.2.1.2 of this Paragraph. These costs shall not include amounts paid in accordance with other provisions hereof.

The total sum to be paid the Contractor under this Subparagraph 12.2.1 shall not exceed the total Contract Price, as properly adjusted, reduced by the amount of payments otherwise made, and shall in no event include duplication of payment.

## **12.2.2 For Cause**

12.2.2.1 If the Contractor persistently or repeatedly refuses or fails to perform the Work in a timely manner, supply enough properly skilled Workers, supervisory personnel or proper equipment or materials, or if it fails to make prompt payment to Subcontractors, or for materials or labor, or persistently disregards laws, ordinances, rules, regulations or orders of any public authority having jurisdiction, or otherwise substantially violates a material provision of this Agreement, then the Owner may, by written notice to the Contractor, without prejudice to any other right or remedy, terminate the employment of the Contractor and take possession of the site and of all materials, equipment, tools, construction equipment and machinery thereon owned by the Contractor and may finish the Work by whatever methods it may deem expedient. In such case, the Contractor shall not be entitled to receive any further payment until the Work is finished.

12.2.2.2 If the unpaid balance of the Contract Price less any liquidated damages due under this Agreement, exceeds the cost of finishing the Work, including compensation for the Project Director's additional services and expenses made necessary thereby, such exceed the unpaid balance, the Contractor shall pay the difference to the Owner. This obligation for payment shall survive the termination of the Contract.

12.2.2.3 In the event the employment of the Contractor is terminated by the Owner for cause pursuant to Subparagraph 12.2.2 and it is subsequently determined by a Court of competent jurisdiction that such termination was without cause, such termination shall thereupon be deemed a Termination for Convenience under Subparagraph 12.2.1 and the provisions of Subparagraph 12.2.1 shall apply.

## **ARTICLE XIII INSURANCE**

### **13.1 Contractor's Insurance:**

The Contractor shall not commence work under this Agreement until he/she has obtained all insurance required under this section and such insurance has been approved by the County. All insurance policies shall be issued by companies authorized to do business under the laws of the State of Florida. The Contractor shall furnish proof of Insurance to the County prior to the commencement of operations. The Certificate(s) shall clearly indicate the Contractor has obtained insurance of the type, amount, and classification as required by contract and that no material change or cancellation of the insurance shall be effective without thirty (30) days prior written notice to the County. **Certificates shall specifically include the County as Additional Insured for all lines of coverage except Workers' Compensation and Professional Liability. A copy of the endorsement must accompany the certificate.** Compliance with the foregoing requirements shall not relieve the Contractor of its liability and obligations under this Agreement.

Certificate Holder Address: St. Johns County, a political subdivision of the State of Florida  
500 San Sebastian View  
St. Augustine, FL 32084

The Contractor shall maintain during the life of this Agreement, Comprehensive General Liability Insurance with minimum limits of \$1,000,000 per occurrence, \$2,000,000 aggregate, to protect the Contractor from claims for damages for bodily injury, including wrongful death, as well as from claims of property damages which may arise from any operations under this contract, whether such operations be by the Contractor or by anyone directly employed by or contracting with the Contractor.

The Contractor shall maintain Umbrella or Excess Liability Insurance covering workers compensation, commercial general liability and business auto liability with minimum limits of liability of \$1,000,000.

The Contractor shall maintain during the life of this Contract, Comprehensive Automobile Liability Insurance with minimum limits of \$2,000,000 combined single limit for bodily injury and property damage liability to protect the Contractor from claims for damages for bodily injury, including the ownership, use, or maintenance of owned and non-owned automobiles, including rented/hired automobiles whether such operations be by the Contractor or by anyone directly or indirectly employed by a Contractor.

The Contractor shall maintain during the life of this Agreement, adequate Workers' Compensation Insurance in at least such amounts as is required by the law for all of its employees per Florida Statute 440.02.

The Contractor shall maintain during the life of this Agreement, Professional Liability or Errors and Omissions Insurance with minimum limits of \$1,000,000, if applicable.

In the event of unusual circumstances, the County Administrator or his designee may adjust these insurance requirements.

## **ARTICLE XIV MISCELLANEOUS**

### **14.1 Governing Law & Venue**

14.1.1 The Contract shall be governed by the laws of the State of Florida. Venue for any administrative and/or legal action arising under the Contract shall be St. Johns County, Florida.

### **14.2 Successors and Assigns**

14.2.1 The Owner and Contractor bind themselves, their successors, assigns and legal representatives to the other party hereto and to successors, assigns and legal representatives of such other party in respect to covenants, agreements and obligations contained in this Agreement. The Contractor shall not assign this Agreement without written consent of the Owner.

### **14.3 Surety Bonds**

14.3.1 The Contractor shall furnish a separate Public Construction Bond to the Owner. Such Bonds shall set forth a penal sum in an amount not less than the Contract Price. The Bond furnished by the Contractor shall incorporate by reference the terms of this Agreement as fully as though they were set forth verbatim in such Bonds. The Public Construction Bond shall provide that in the event the Contract Price is adjusted by Change Order executed by the Contractor. The Public Construction Bond furnished by the Contractor shall be in form suitable to the Owner and shall be

executed by a Surety, or Sureties, reasonably suitable to the Owner.

#### **14.4. Safety of Persons and Property**

14.4.1 When existing utility lines shown on the Drawings are to be removed or relocated, the Contractor shall notify the Engineer in ample time for taking measures for prevention of the interruption of any required services prior to the beginning of operations. In the event that the Contractor damages any existing utility lines not shown on the Drawings, the location of which is not known to the Contractor report thereof shall be made immediately to the Engineer.

14.4.2 Locations of existing utility lines shown on the Drawings are based on the best information available to the Engineer, but shall not be considered exact either as to location or number of such lines.

14.4.3 Contractor shall protect utility lines constructed under terms of the agreement and those discovered or shown on Drawings to be existing. Damage occurring to utility lines due to Contractor's operations shall be repaired at no cost to the Owner.

### **ARTICLE XV EQUAL EMPLOYMENT OPPORTUNITY**

#### **15.1 Contractor's Employment Opportunity**

15.1.1 The Contractor and all Subcontractors shall not discriminate against any employee or applicant for employment because of race, religion, color, sex, national origin or age.

The Contractor shall take affirmative action to insure that applicants are employed, and that employees are treated during employment without regard to their race, religion, color, sex, national origin or age. Such action shall include, but not be limited to, the following: employment, upgrading, demotion or transfer, recruitment or recruitment advertisement, layoff or termination, rates of pay or other forms of compensation, and selection for training, including apprenticeship. The Contractor agrees to post in conspicuous places, available to employees and applicants for employment, notices setting forth the policies of non-discrimination.

15.1.2 The Contractor and all Subcontractors shall, in all solicitations or advertisements for employees placed by them or on their behalf, state that all qualified applicants shall receive consideration for employment without regard to race, religion, color, sex, national origin or age.

### **ARTICLE XVI APPRENTICESHIP LAW REQUIREMENTS**

#### **16.1 Apprenticeship Law (Chapter 446, Florida Statutes)**

16.1.1 The Contractor shall make a diligent effort to hire for Performance of the Contract a number of apprentices in each occupation which bears to the average number of journeyman in that occupation to be employed in the performance of the Contract, the ratio of at least one (1) apprentice or trainee to every five (5) journeymen:

16.1.2 The Contractor shall, when feasible and except when the number of apprentices or trainees to be hired is fewer than four (4), assure that twenty-five (25) percent of such apprentices or trainees are in their first year of training. Feasibility here involves a consideration of the availability of training opportunities for first year apprentices or trainees, the hazardous nature of the Work for beginning workers, and excessive unemployment of apprentices or trainees in their second or subsequent years of training.

16.1.3 The Contractor, during the performance of the Contract, shall make diligent efforts to employ the number of apprentices or trainees necessary to meet requirements of Subparagraphs a. and b. However, on-the-job training programs shall only be established in non-apprenticable trades or occupations to meet the requirements of this section.

16.1.4 The Contractor agrees to return records of employment, by trade, of the number of apprentices or trainees by first year of training, and the number of journeymen and the wages paid, and hours of work, of such persons on a form as prescribed by the Bureau of Apprenticeship of the Division of Labor at three (3) month intervals. Submission of duplicate copies of forms submitted to the United States Department of Labor shall be sufficient compliance with the provisions of the section.

16.1.5 The Contractor agrees to supply the Bureau of Apprenticeship of the Division of Labor, at three (3) months intervals, a statement describing steps taken toward making diligent effort and containing a breakdown by craft or hours



worked and wages paid for first year apprentices or trainees, other apprentices or trainees and journeymen.

16.1.6 The Contractor agrees to insert in any Subcontract under this Agreement the requirements contained in this section. "The term Contractor" as used in such clauses and any Subcontract shall mean the Subcontractor.

16.1.7 Anything herein to the contrary notwithstanding, Contractor agrees to comply with all of the provisions of Florida Statutes 446 and all regulations prescribed by the Bureau of Apprenticeship of the Division of Labor.

## **ARTICLE XVII PUBLIC RECORDS**

### **17.1 Public Records**

17.1.1 The cost of reproduction, access to, disclosure, non-disclosure, or exemption of records, data, documents, and/or materials, associated with this Agreement shall be subject to the applicable provisions of the Florida Public Records Law (Chapter 119, Florida Statutes), and other applicable State and Federal provisions. Access to such public records, may not be blocked, thwarted, and/or hindered by placing the public records in the possession of a third party, or an unaffiliated party.

17.1.2 In accordance with Florida law, to the extent that Contractor's performance under this Contract constitutes an act on behalf of the County, Contractor shall comply with all requirements of Florida's public records law. Specifically, if Contractor is expressly authorized, and acts on behalf of the County under this Agreement, Contractor shall:

- (1) Keep and maintain public records that ordinarily and necessarily would be required by the County in order to perform the Services;
- (2) Upon request from the County's custodian of public records, provide the County with a copy of the requested records or allow the records to be inspected or copied within a reasonable time at a cost that does not exceed the cost as provided in Chapter 119, Florida Statutes, or as otherwise provided by law;
- (3) Ensure that public records related to this Agreement that are exempt or confidential and exempt from public records disclosure requirements are not disclosed except as authorized by applicable law for the duration of this Agreement and following completion of this Agreement if the Contractor does not transfer the records to the County; and
- (4) Upon completion of this Agreement, transfer, at no cost, to the County all public records in possession of the Contractor or keep and maintain public records required by the County to perform the Services.

17.1.3 If the Contractor transfers all public records to the County upon completion of this Agreement, the Contractor shall destroy any duplicate public records that are exempt or confidential and exempt from public records disclosure requirements. If the Contractor keeps and maintains public records upon completion of this Agreement, the Contractor shall meet all applicable requirements for retaining public records. All records stored electronically must be provided to the County, upon request from the County's custodian of public records, in a format that is compatible with the County's information technology systems.

17.1.4 Failure by the Contractor to comply with the requirements of this section shall be grounds for immediate, unilateral termination of this Agreement by the County.

**IF THE CONTRACTOR HAS QUESTIONS REGARDING THE APPLICATION OF CHAPTER 119, FLORIDA STATUTES, TO ITS DUTY TO PROVIDE PUBLIC RECORDS RELATING TO THIS AGREEMENT, CONTACT THE CUSTODIAN OF PUBLIC RECORDS AT: OCA, ATTN: Public Records Manager, 500 San Sebastian View, St. Augustine, FL 32084, PH: (904) 209-0805, EMAIL: [publicrecords@sjcfl.us](mailto:publicrecords@sjcfl.us).**

**BID NO: 18-32, Northwest WTP 20 Inch Water Main Extension**

**Owner**

St. Johns County, FL (Seal)

(Typed Name)

By: \_\_\_\_\_  
Signature of Authorized Representative

Jaime T. Locklear, MPA, CPPB, FCCM  
Printed Name

Assistant Purchasing Manager  
Title

\_\_\_\_\_  
Date of Execution

**Contractor**

G&H Underground Construction, Inc. (Seal)

(Typed Name)

By: \_\_\_\_\_  
Signature of Authorized Representative

\_\_\_\_\_  
Printed Name & Title

\_\_\_\_\_  
Date of Execution

**ATTEST:**  
**St. Johns County, FL**  
**Clerk of Courts**

By: \_\_\_\_\_  
Deputy Clerk

\_\_\_\_\_  
Date of Execution

**Legally Sufficient:**

\_\_\_\_\_  
Deputy County Attorney

\_\_\_\_\_  
Date of Execution



## St. Johns County Board of County Commissioners

Purchasing Division

### NOTICE OF INTENT TO AWARD

January 23, 2018

**RE:** Bid No: 18-32 – Northwest WTP 20 Inch Water Main Extension

Please be advised that the Purchasing Department of St. Johns County is issuing this notice of its Intent to Award a contract to G&H Underground Construction, Inc. as the lowest responsive, responsible bidder for Bid No: 18-32 – Northwest WTP 20 Inch Water Main Extension. This notice will remain posted **St. Johns County Purchasing Department bulletin board** until 2:00 PM, Friday, January 26, 2018.

Any person (including any bidder or proposer) who is, or claims to be, adversely affected by the County's decision or proposed decision shall file a written Notice of Protest with the Purchasing Department of St. Johns County within 72 hours after the posting of the notice of decision or proposed decision. Failure to file a Notice of Protest within the time prescribed in Section 304.10 of the St. Johns County Purchasing Manual (the Bid Protest Procedure), or failure to post the bond or other security required by the County within the time allowed for filing a bond, shall constitute a waiver of proceedings and a waiver of the right to protest. The protest procedures may be obtained from the Purchasing Department and are included in the County's Purchasing Manual. All of the terms and conditions of the County Purchasing Manual are incorporated herein by reference and are fully binding.

Should the Purchasing Department receive no protests in response to this notice, an agenda item will be submitted to the St. Johns County Board of County Commissioners for their consideration and subsequent approval to award a contract.

Please forward all correspondence, requests or inquiries directly to my attention at the information provided below.

Sincerely,  
St. Johns County  
Board of County Commissioners

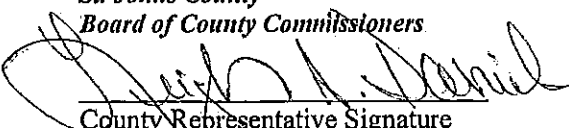
  
County Representative Signature

Date: 1/23/18

Leigh A. Daniels, CPPB,  
Procurement Supervisor  
(904) 209-0154 – Direct  
(904) 209-0155 – Fax  
[ldaniels@sjcfl.us](mailto:ldaniels@sjcfl.us)



ST. JOHNS COUNTY  
PURCHASING DEPARTMENT

500 San Sebastian View  
St. Augustine, Florida 32084

INTEROFFICE MEMORANDUM

TO: Scott Trigg, P.E., Chief Engineer – Capital Projects  
FROM: Leigh Daniels, CPPB, Procurement Supervisor  
SUBJECT: Department Approval for Bid No. 18-32, Northwest WTP 20 Inch Water Main Extension  
DATE: January 10, 2018

Attached is a copy of the technical proposal review summary sheet.

Please review, evaluate and make a written recommendation for this project. Also, indicate the budgeted amount for this item along with the appropriate charge code and return at your earliest convenience. We will prepare the agenda item and contract.

Please let me know if I can assist your department in any other way.

Department Head Approval Scott Trigg  
Date 1/23/18  
Budget Amount \$250,000.00  
Account Funding Title 2018 NW WTP Expansion  
Funding Charge Code 4484-56302-6258-56302  
Award to G#H Underground Construction, Inc.  
Award Amount \$222,020.00

ST JOHNS COUNTY

JAN 23 '18

PURCHASING

BID NO: 18-32

OFFICIAL COUNTY BID FORM  
ST. JOHNS COUNTY, FLORIDA

PROJECT: NORTHWEST WTP 20 INCH WATER MAIN EXTENSION

TO: THE BOARD OF COUNTY COMMISSIONERS OF ST. JOHNS COUNTY, FLORIDA

DATE SUBMITTED: 1-10-2018

BID PROPOSAL OF

G&H Underground Construction Inc  
Full Legal Company Name

2200 N Ponce De Leon Blvd St Augustine, Fl. 32084	904-829-8199	904-810-0531
Mailing Address	Telephone Number	Fax Number

Bidders: Having become familiar with requirements of the project, and having carefully examined the Bidding Documents and Specifications entitled for Bid No: 18-32, Northwest WTP 20 Inch Water Main Extension in St. Johns County, Florida, the undersigned proposes to furnish all materials, labor and equipment, supervision and all other requirements necessary to comply with the Contract Documents to submit the following Bid Proposal summarized as follows:

TOTAL LUMP SUM BID PRICE: (As per plans and specifications)

\$ 222,020.00  
Total Lump Sum Bid Price (Numerical)

Two hundred twenty two thousand and twenty dollars /100 Dollars  
Total Lump Sum Bid Price (Amount written or typed in words)

Bidder shall insert the Total Lump Sum Bid Price in numerals and in words. Any discrepancy between the two submitted amounts shall be determined by the amount written in words.

During the preparation of the Bid, the following addenda, if any, were received:

No.: 1 Date Received: 12-19-17

No.: 2 Date Received: 12-22-17

No.: 3 Date Received: 12-27-17

We, the undersigned, hereby declare that no person or persons, firm or corporation, other than the undersigned are interested, in this proposal, as principals, and that this proposal is made without collusion with any person, firm or corporation, and we have carefully and to our satisfaction examined the Bid Documents and Project Specifications.

We have made a full examination of the location of the proposed work and the sources of supply of materials, and we hereby agree to furnish all necessary labor, equipment and materials, fully understanding that any quantities shown therewith are approximate only, and that we will fully complete all requirements therein as prepared by the Owner, within the same time limit specified in the Bid Documents as indicated above.

If the Undersigned is notified of the acceptance of this Bid Proposal by the Board within ninety (90) calendar days for the time set for the opening of Bids, the Undersigned further agrees, to execute a contract for the above work within ten (10) days after notice that his Bid has been accepted for the above stated compensation in the form of a Contract presented by the Owner.

The Undersigned further agrees that security in the form of a Bid Bond, certified or cashier's check in the amount of not less than five percent (5%) of Total Lump Sum Bid Price, payable to the Owner, accompanies this Bid; that the amount is not to be construed as a penalty, but as liquidated damages which said Owner will sustain by failure of the Undersigned to execute and deliver the Contract and Bond within ten (10) days of the written notification of the Award of the Contract to him; thereupon, the security shall become the property of the Owner, but if this Bid is not accepted within ninety (90) days of the time set for the submission of Bids, or if the Undersigned delivers the executed Contract upon receipt, the Security shall be returned to the Bidder within seven (7) working days.

**CORPORATE/COMPANY**

Full Legal Company Name: G&H Underground Construction, Inc (Seal)

By: [Signature] Wade Gibby, President  
Signature of Authorized Representative (Name & Title typed or printed)

By: \_\_\_\_\_  
Signature of Authorized Representative (Name & Title typed or printed)

Address: 2200 Ponce De Leon Blvd Ste 11 St Augustine, Fl. 32084

Telephone No.: (904) 829-8199 Fax No.: (904) 810-0531

Email Address for Authorized Company Representative: ghunderground@bellsouth.net

Federal I.D. Tax Number: 06-1747700 DUNS #: \_\_\_\_\_  
(If applicable)

**INDIVIDUAL**

Name: \_\_\_\_\_  
(Signature) (Name typed or printed) (Title)

Address: \_\_\_\_\_

Telephone No.: (\_\_\_\_) \_\_\_\_\_ Fax No.: \_\_\_\_\_

Email Address: \_\_\_\_\_

Federal I.D. Tax Number: \_\_\_\_\_

- Submittal Requirements:
- Official County Unit Price Bid Form
  - Attachment "A" – St Johns County Board of County Commissioners Affidavit.
  - Attachment "B" – Certificate as to Corporate Principal
  - Attachment "C" – License / Certification List
  - Attachment "D" – List of Proposed Sub-Contractors/Suppliers
  - Attachment "E" – Conflict of Interest Disclosure Form
  - Attachment "F" – Certificate of Compliance with Florida Trench Safety Act
  - Attachment "G" – Proof of Insurance
  - Attachment "H" – Experience of Bidder Form
  - Bid Bond Form
  - Fully Acknowledged Addenda Applicable to this bid

Official County Bid Form, Attachments "A", "B", "C", "D", "E", "F", "G", "H" and Bid Bond must be completed, along with a fully acknowledged copy of each Addendum applicable to this Bid and submitted with each copy of the Bid Proposal. One (1) original and two (2) copies of all required forms must be submitted.

BID NO.: 18-32

ATTACHMENT "A"

**ST. JOHNS COUNTY, BOARD OF COUNTY COMMISSIONERS AFFIDAVIT**

TO: ST. JOHNS COUNTY, BOARD OF COUNTY COMMISSIONERS,  
ST. JOHNS COUNTY, ST. AUGUSTINE, FLORIDA.

At the time the proposal is submitted, the Bidder shall attach to his Bid a sworn statement.

This sworn statement shall be an affidavit in the following form, executed by an officer of the firm, association, or corporation submitting the proposal, and shall be sworn to before a person who is authorized by law to administer oaths.

STATE OF FLORIDA, COUNTY OF ST. JOHNS

Before me, the Undersigned authority, personally appeared Wade Gibby who being duly sworn, deposes and says he is President (Title) of the firm of G&H Underground Construction, Inc Bidder submitting the attached proposal for the services covered by the bid documents for Bid No: 18-32, Northwest WTP 20 Inch Water Main Extension, in St. Johns County, Florida.

The affiant further states that no more that one proposal for the above-referenced project will be submitted from the individual, his firm or corporation under the same or different name, and that such Bidder has no financial interest in the firm of another bidder for the same work. That neither he, his firm, association nor corporation has either directly or indirectly entered into any agreement, participated in any collusion, nor otherwise taken any action in restraint of free competitive bidding in connection with this firm's Bid on the above-described project. Furthermore, neither the firm nor any of its officers are barred from participating in public contract lettings in the State of Florida or any other state.

G&H Underground Construction, Inc

(Bidder)  
By: [Signature]  
President  
(Title)

Sworn and subscribed to me this 10th day  
of January, 2018.

Notary Public:  
[Signature]  
Signature  
Jennifer Smith  
Printed

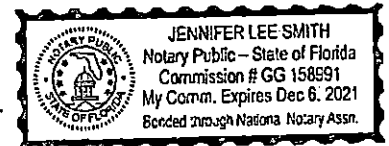

My commission Expires: 12-6-2021

BIDDER ON ALL COUNTY PROJECTS MUST EXECUTE AND ATTACH THIS AFFADAVIT TO EACH BID.



BID NO.: 18-32

**ATTACHMENT "B"**  
**CERTIFICATES AS TO CORPORATE PRINCIPAL**

I, Wade Gibby, certify that I am the Secretary of the Corporation named as Principal in the attached bond; that Wade Gibby who signed the said bond on behalf of the Principal, was then President of said Corporation; that I know his signature, and his signature hereto is genuine; and that said bond was duly signed, sealed, and attested for and in behalf of said Corporation by authority of its governing body.

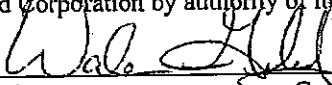

Secretary

Corporate Seal

(STATE OF FLORIDA  
COUNTY OF ST. JOHNS)

Before me, a Notary Public duly commissioned, qualified and acting, personally appeared Ben Powell to me well known, who being by me first duly sworn upon oath, says that he is the Attorney-In-Fact, for the Surety and that he has been authorized by Merchants Bonding to execute the foregoing bond on behalf of the surety named therein in favor of St. Johns County, Florida.

Subscribed and sworn to me this 10th day of January, 2018, A.D.

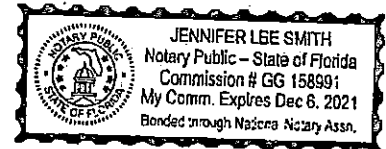

NOTARY PUBLIC  
State of Florida-at-large

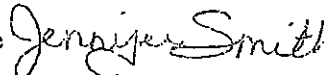

My Commission Expires: 12-6-2021

(Attach Power of Attorney to original Bid Bond and Financial Statement of Surety Company)





**Florida Department of Transportation**

RICK SCOTT  
GOVERNOR

605 Suwannee Street  
Tallahassee, FL 32399-0450

RACHEL D. CONE  
INTERIM SECRETARY

May 9, 2017

G&H UNDERGROUND CONSTRUCTION INC  
2200 N PONCE DE LEON BLVD  
ST AUGUSTINE, FL

RE: CERTIFICATE OF QUALIFICATION

Dear Sir/Madam:

The Department of Transportation has qualified your company for the type of work indicated below. Unless your company is notified otherwise, this Certificate of Qualification will expire 6/30/2018. However, the new application is due 4/30/2018.

In accordance with S.337.14 (1) F.S. your next application must be filed within (4) months of the ending date of the applicant's audited annual financial statements.

If your company's maximum capacity has been revised, you can access it by logging into the Contractor Prequalification Application System via the following link:  
[HTTPS://fdotwpl.dot.state.fl.us/ContractorPreQualification/](https://fdotwpl.dot.state.fl.us/ContractorPreQualification/)

Once logged in, select "View" for the most recently approved application, and then click the "Manage" and "Application Summary" tabs.

**FDOT APPROVED WORK CLASSES:**  
DRAINAGE, FLEXIBLE PAVING, GRADING, GRASSING, SEEDING AND SODDING, SIDEWALK, Underground Utilities (Water & Sewer).

You may apply for a Revised Certificate of Qualification at any time prior to the expiration date of this certificate according to Section 14-22.0041(3), Florida Administrative Code (F.A.C.), by accessing your most recently approved application as shown above and choosing "Update" instead of "View." If certification in additional classes of work is desired, documentation is needed to show that your company has done such work with your own forces and equipment or that experience was gained with another contractor and that you have the necessary equipment for each additional class of work requested.

All prequalified contractors are required by Section 14-22.006(3), F.A.C., to certify their work underway monthly in order to adjust maximum bidding capacity to available bidding capacity. You can find the link to this report at the website shown above.

Sincerely,

Alan Autry, Manager  
Contracts Administration Office

THIS RECEIPT IS ISSUED PURSUANT  
TO COUNTY ORDINANCE 37-35

# 2017/2018 ST. JOHNS COUNTY LOCAL BUSINESS TAX RECEIPT

MUST BE DISPLAYED IN A CONSPICUOUS PLACE

ACCOUNT 25043  
EXPIRES September 30, 2018

TYPE OF BUSINESS 000264 LAND CLEARING SERVICE

BUSINESS ADDRESS 2200 N PONCE DE LEON BLVD STE 11  
ST. AUGUSTINE, FL 32084

BUSINESS NAME G & H CONSTRUCTION  
OWNER GIBBY WADE D & HARDWICK JEFFERY

MAILING ADDRESS 2200 N PONCE DE LEON BLVD #11  
ST. AUGUSTINE, FL 32084

X NEW BUSINESS TRANSFER ORIGINAL TAX	22.00
AMOUNT	22.00
PENALTY	.00
COLLECTION COST	
TOTAL	22.00

THIS FORM BECOMES A RECEIPT ONLY WHEN VALIDATED

PAID-8154673-0001-0001 501 09/28/2017 22.00

**DENNIS W. HOLLINGSWORTH**  
**ST. JOHNS COUNTY TAX COLLECTOR**

This receipt does not constitute a franchise, an agreement, or permission or authority to perform the services or operate the business described herein when a franchise, agreement, or other county commission, state or federal permission or authority is required by county, state or federal law.

RICK SCOTT, GOVERNOR

KEN LAWSON, SECRETARY

## STATE OF FLORIDA DEPARTMENT OF BUSINESS AND PROFESSIONAL REGULATION CONSTRUCTION INDUSTRY LICENSING BOARD

LICENSE NUMBER	
CUC1224124	

The UNDERGROUND UTILITY & EXCAVATION CO  
Named below IS CERTIFIED  
Under the provisions of Chapter 489 FS.  
Expiration date: AUG 31, 2018



HARDWICK, JEFFERY L  
G & H UNDERGROUND CONSTRUCTION INC  
4980 PORTER ROAD  
ST. AUGUSTINE FL 32095



ISSUED: 06/22/2016

DISPLAY AS REQUIRED BY LAW

SEQ # L1606220001195



BID NO.: 18-32

ATTACHMENT "E"

**St. Johns County Board of County Commissioners  
Conflict of Interest Disclosure Form**

Project (RFQ, RFP, BID) Number/Description: Bid No 18-32; Northwest WTP 20 inch Water Main Extension

The term "conflict of interest" refers to situations in which financial or other considerations may adversely affect, or have the appearance of adversely affecting a consultant's/contractor's professional judgment in completing work for the benefit of St. Johns County ("County"). The bias such conflicts could conceivably impart may inappropriately affect the goals, processes, methods of analysis or outcomes desired by the County.

Consultants/Contractors are expected to safeguard their ability to make objective, fair, and impartial decisions when performing work for the benefit of the County. Consultants/Contractors, therefore must there avoid situations in which financial or other considerations may adversely affect, or have the appearance of adversely affecting the consultant's/contractor's professional judgement when completing work for the benefit of the County.

The mere appearance of a conflict may be as serious and potentially damaging as an actual distortion of goals, processes, methods of analysis or outcomes. Reports of conflicts based upon appearances can undermine public trust in ways that may not be adequately restored even when the mitigating facts of a situation are brought to light. Apparent conflicts, therefore, should be disclosed and evaluated with the same vigor as actual conflicts.

It is expressly understood that failure to disclose conflicts of interest as described herein may result in immediate disqualification from evaluation or immediate termination from work for the County.

Please check the appropriate statement:



I hereby attest that the undersigned Respondent has no actual or potential conflict of interest due to any other clients, contracts, or property interests for completing work on the above referenced project.



The undersigned Respondent, by attachment to this form, submits information which may be a potential conflict of interest due to other clients, contracts or property interests for completing work on the above referenced project.

Legal Name of Respondent:

G&H Underground Construction, Inc

Authorized Representative(s) :

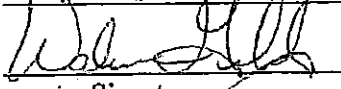
  
Signature

Wade Gibby/ President

Print Name/Title

\_\_\_\_\_  
Signature

\_\_\_\_\_  
Print Name/Title

BID NO.: 18-32

ATTACHMENT "F"

CERTIFICATE OF COMPLIANCE WITH FLORIDA TRENCH SAFETY ACT

Bidder acknowledges that he is solely responsible for complying with the Florida Trench Safety Act (ACT) and Occupational Safety and Health Administrations excavation safety standard 29 CFR 1926.650 (Subpart P as amended) and the St. Johns County Trenching and Excavation Safety Program. If there is a conflict between the ACT and the St. Johns County Trenching and Excavation Safety Program, the more stringent requirement would apply. Bidder further acknowledges that included in the various items of the proposal and in the Total Bid Price are costs for complying with the Florida Trench Safety Act (90-96, Laws of Florida) effective October 1, 1990 and the Occupational Safety and Health Administrations excavation safety standard.

By: Wade Gibby

G&H Underground Construction, Inc

Bidder



Authorized Signature

1-10-18

Date

**BID NO.: 18-32**

**ATTACHMENT "G"**

**CERTIFICATE OF INSURANCE**

INSERT CERTIFICATE OF INSURANCE HERE





G&amp;HUNDE-01

JSMITH

### CERTIFICATE OF LIABILITY INSURANCE

DATE (MM/DD/YYYY)

06/07/2017

THIS CERTIFICATE IS ISSUED AS A MATTER OF INFORMATION ONLY AND CONFERS NO RIGHTS UPON THE CERTIFICATE HOLDER. THIS CERTIFICATE DOES NOT AFFIRMATIVELY OR NEGATIVELY AMEND, EXTEND OR ALTER THE COVERAGE AFFORDED BY THE POLICIES BELOW. THIS CERTIFICATE OF INSURANCE DOES NOT CONSTITUTE A CONTRACT BETWEEN THE ISSUING INSURER(S), AUTHORIZED REPRESENTATIVE OR PRODUCER, AND THE CERTIFICATE HOLDER.

**IMPORTANT:** If the certificate holder is an ADDITIONAL INSURED, the policy(ies) must have ADDITIONAL INSURED provisions or be endorsed. If SUBROGATION IS WAIVED, subject to the terms and conditions of the policy, certain policies may require an endorsement. A statement on this certificate does not confer rights to the certificate holder in lieu of such endorsement(s).

PRODUCER Cecil W. Powell & Company 219 N. Newnan Street Jacksonville, FL 32202	CONTACT NAME: Joanne Smith, CIC	
	PHONE (A/C, No, Ext): (904) 353-3181	FAX (A/C, No): (904) 353-5722
E-MAIL ADDRESS: Jsmith@cwpowellins.com		INSURER(S) AFFORDING COVERAGE
INSURER A: Southern Owners Ins Co		NAIC # 10190
INSURER B: Owners Insurance Co		27000
INSURER C: Bridgefield Casualty Ins Co		
INSURER D:		
INSURER E:		
INSURER F:		

INSURED  
G & H Underground Construction, Inc.  
1175 Woodlawn Rd.  
St. Augustine, FL 32084

## COVERAGES

CERTIFICATE NUMBER:

REVISION NUMBER:

THIS IS TO CERTIFY THAT THE POLICIES OF INSURANCE LISTED BELOW HAVE BEEN ISSUED TO THE INSURED NAMED ABOVE FOR THE POLICY PERIOD INDICATED. NOTWITHSTANDING ANY REQUIREMENT, TERM OR CONDITION OF ANY CONTRACT OR OTHER DOCUMENT WITH RESPECT TO WHICH THIS CERTIFICATE MAY BE ISSUED OR MAY PERTAIN, THE INSURANCE AFFORDED BY THE POLICIES DESCRIBED HEREIN IS SUBJECT TO ALL THE TERMS, EXCLUSIONS AND CONDITIONS OF SUCH POLICIES. LIMITS SHOWN MAY HAVE BEEN REDUCED BY PAID CLAIMS.

INSR LTR	TYPE OF INSURANCE	ADDL SUBR INSD	WVD	POLICY NUMBER	POLICY EFF (MM/DD/YYYY)	POLICY EXP (MM/DD/YYYY)	LIMITS
A	<input checked="" type="checkbox"/> COMMERCIAL GENERAL LIABILITY CLAIMS-MADE <input checked="" type="checkbox"/> OCCUR  GEN'L AGGREGATE LIMIT APPLIES PER: <input checked="" type="checkbox"/> POLICY <input type="checkbox"/> PRO JECT <input type="checkbox"/> LOC OTHER:	X	X	7824226117	06/07/2017	06/07/2018	EACH OCCURRENCE \$ 1,000,000 DAMAGE TO RENTED PREMISES (Ea occurrence) \$ 100,000 MED EXP (Any one person) \$ 5,000 PERSONAL & ADV INJURY \$ 1,000,000 GENERAL AGGREGATE \$ 2,000,000 PRODUCTS - COMP/OP AGG \$ 2,000,000 \$
B	AUTOMOBILE LIABILITY <input checked="" type="checkbox"/> ANY AUTO OWNED AUTOS ONLY <input type="checkbox"/> SCHEDULED AUTOS <input type="checkbox"/> HIRED AUTOS ONLY <input type="checkbox"/> NON-OWNED AUTOS ONLY			5124226100	06/07/2017	06/07/2018	COMBINED SINGLE LIMIT (Ea accident) \$ 1,000,000 BODILY INJURY (Per person) \$ BODILY INJURY (Per accident) \$ PROPERTY DAMAGE (Per accident) \$ Pers Inj Protec \$ 10,000
A	<input checked="" type="checkbox"/> UMBRELLA LIAB <input checked="" type="checkbox"/> OCCUR <input type="checkbox"/> EXCESS LIAB <input type="checkbox"/> CLAIMS-MADE CED RETENTION \$			5124226101	06/07/2017	06/07/2018	EACH OCCURRENCE \$ 1,000,000 AGGREGATE \$ 1,000,000 \$
C	WORKERS COMPENSATION AND EMPLOYERS' LIABILITY ANY PROPRIETOR/PARTNER/EXECUTIVE OFFICER/MEMBER EXCLUDED? (Mandatory in NH) If yes, describe under DESCRIPTION OF OPERATIONS below	Y/N	N/A	19643270	06/07/2017	06/07/2018	<input checked="" type="checkbox"/> PER STATUTE <input type="checkbox"/> OTHER E.L. EACH ACCIDENT \$ 1,000,000 E.L. DISEASE - EA EMPLOYEE \$ 1,000,000 E.L. DISEASE - POLICY LIMIT \$ 1,000,000

DESCRIPTION OF OPERATIONS / LOCATIONS / VEHICLES (ACORD 101, Additional Remarks Schedule, may be attached if more space is required)  
 St. Johns County Board of County Commissioners is an additional insured and a waiver of subrogation applies with respect to general liability per the attached policy forms.

## CERTIFICATE HOLDER

## CANCELLATION

St. Johns County Board of County Commissioners  
500 San Sebastian View  
Saint Augustine, FL 32084

SHOULD ANY OF THE ABOVE DESCRIBED POLICIES BE CANCELLED BEFORE THE EXPIRATION DATE THEREOF, NOTICE WILL BE DELIVERED IN ACCORDANCE WITH THE POLICY PROVISIONS.

AUTHORIZED REPRESENTATIVE

*Susan Jordan*

BID NO.: 18-32

ATTACHMENT "H"

**EXPERIENCE OF BIDDER**

Bidder acknowledges that he is fully licensed to perform work in the STATE OF FLORIDA.

The Bidder shall provide the following information regarding experience within the past five (5) years of this solicitation. Bidder must demonstrate the successful completion of three (3) projects of similar complexity, nature, size, and dollar amount of project.

Any material misrepresentation, as determined by the County, shall result in disqualification.

By: G&H Underground Construction, Inc

1-10-18  
Date

Bidder  
  
Authorized Signature

DATE OF CONTRACT	CLIENT'S NAME, ADDRESS, PHONE AND EMAIL	CONTRACT AMOUNT	PROJECT AND LOCATION
May 2013	City of Jacksonville Beach 1460 A Shetter Ave Jacksonville Beach, Fl. 32250 ddupries@jaxbchfl.net / 904-247-6286	3,597,507.20	Williams Coastal Blvd Heights and South Beach Infrastructure Jacksonville Beach
March 2015	City of St Augustine 75 King St St Augustine, Fl 32085 904-823-2204 / mpinson@citystaug.com	957,551.00	Magnolia Ave Area Water Main Improvements St Augustine, Fl.
May 2017	City of Jacksonville Beach 1460 A Shetter Ave Jacksonville Beach, Fl. 32250 ddupries@jaxbchfl.net / 904-247-6286	357,045.67	Miscellaneous Water Main Replacement- Phase D Jacksonville Beach

Do you have any similar work in progress at this time?  Yes  No

Length of time in business: 12 Years

Is your company currently involved in any active litigation?  No  If Yes, explain: \_\_\_\_\_

Has your company ever been sued?  No  If Yes, explain and/or submit court decision or judgment, as applicable: \_\_\_\_\_

BID NO.: 18-32

BID BOND

STATE OF FLORIDA  
COUNTY OF ST. JOHNS

KNOW ALL MEN BY THESE PRESENTS, that G & H Underground Construction, Inc. as Principal, and as Surety, are held and firmly bound unto St. Johns County, Florida, in the penal sum of Dollars (\$ 5%) lawful money of the United States, we bind ourselves, our heirs, executors, administrators, and successors, jointly and severally, firmly by these presents.  
\*Merchants Bonding Company

THE CONDITION OF THIS OBLIGATIONS IS SUCH that whereas the Principal has submitted the accompanying Bid, dated January 10, 2018.

For  
NORTHWEST WTP 20 INCH WATER MAIN EXTENSION  
St. Johns County, Florida

NOW THEREFORE,

- (a) If the Principal shall not withdraw said Bid within ninety (90) days after Bid Award date, and shall within ten (10) days after prescribed forms are presented to him for signature, enter into a written Contract with the County in accordance with the Bid as accepted, and give Bond with good and sufficient Surety or Sureties, as may be required, for the faithful performance and proper fulfillment of such Contract, then the above obligations shall be void and of no effect, otherwise to remain in full force and virtue.
- (b) In the event of the withdrawal of said Bid within the period specified, or the failure to enter into such Contract and give such Bond within the time specified, if the Principal shall pay the County the difference between the amount specified in said Bid and the amount for which the County may procure the required Work and supplies, if the latter amount be in excess of the former, then the above obligations shall be void and of no effect, otherwise to remain in full force and virtue.

IN WITNESS WHEREOF, the above bounded parties have executed this instrument under their several seals, this day of January 10th, A.D., 2018, the name and corporate seal of each corporate party being hereto affixed and these presents duly signed by its undersigned representative, pursuant to authority of its governing body.

BID NO.: 18-32

WITNESSES:

(If Sole Ownership or Partnership two (2) Witnesses required).  
(If Corporation, Secretary only will attest and affix seal).

WITNESSES:

Diie Aburnathy  
Jenny Smith  
\_\_\_\_\_

Wade H. H.  
PRINCIPAL:

G & H Underground Construction, Inc.

NAME OF FIRM:

Wade H. H.  
SIGNATURE OF AUTHORIZED  
OFFICER (AFFIX SEAL)

TITLE

2200 N. Ponce De Leon Blvd. Ste. 11

BUSINESS ADDRESS

Jacksonville, FL

CITY

STATE

WITNESS:

Benjamin K. Powell

SURETY:

Merchants Bonding Company

CORPORATE SURETY

Benjamin K. Powell  
ATTORNEY-IN-FACT (AFFIX SEAL)

Benjamin K. Powell

P.O. Box 14498

BUSINESS ADDRESS

Des Moines, IA

CITY

STATE

Cecil W. Powell & Company

NAME OF LOCAL INSURANCE AGENCY



**MERCHANTS**  
BONDING COMPANY  
**POWER OF ATTORNEY**

Know All Persons By These Presents, that MERCHANTS BONDING COMPANY (MUTUAL) and MERCHANTS NATIONAL BONDING, INC., both being corporations of the State of Iowa (herein collectively called the "Companies") do hereby make, constitute and appoint, individually, Benjamin Powell; Fitzhugh K Powell Jr; Robert T Theus; Susan W Jordan

their true and lawful Attorney(s)-in-Fact, to sign its name as surety(ies) and to execute, seal and acknowledge any and all bonds, undertakings, contracts and other written instruments in the nature thereof, on behalf of the Companies in their business of guaranteeing the fidelity of persons, guaranteeing the performance of contracts and executing or guaranteeing bonds and undertakings required or permitted in any actions or proceedings allowed by law.

This Power-of-Attorney is granted and is signed and sealed by facsimile under and by authority of the following By-Laws adopted by the Board of Directors of Merchants Bonding Company (Mutual) on April 23, 2011 and amended August 14, 2015 and adopted by the Board of Directors of Merchants National Bonding, Inc., on October 16, 2015.

"The President, Secretary, Treasurer, or any Assistant Treasurer or any Assistant Secretary or any Vice President shall have power and authority to appoint Attorneys-in-Fact, and to authorize them to execute on behalf of the Company, and attach the seal of the Company thereto, bonds and undertakings, recognizances, contracts of indemnity and other writings obligatory in the nature thereof."

"The signature of any authorized officer and the seal of the Company may be affixed by facsimile or electronic transmission to any Power of Attorney or Certification thereof authorizing the execution and delivery of any bond, undertaking, recognizance, or other suretyship obligations of the Company, and such signature and seal when so used shall have the same force and effect as though manually fixed."

In connection with obligations in favor of the Florida Department of Transportation only, it is agreed that the power and authority hereby given to the Attorney-in-Fact includes any and all consents for the release of retained percentages and/or final estimates on engineering and construction contracts required by the State of Florida Department of Transportation. It is fully understood that consenting to the State of Florida Department of Transportation making payment of the final estimate to the Contractor and/or its assignee, shall not relieve this surety company of any of its obligations under its bond.

In connection with obligations in favor of the Kentucky Department of Highways only, it is agreed that the power and authority hereby given to the Attorney-in-Fact cannot be modified or revoked unless prior written personal notice of such intent has been given to the Commissioner-Department of Highways of the Commonwealth of Kentucky at least thirty (30) days prior to the modification or revocation.

In Witness Whereof, the Companies have caused this instrument to be signed and sealed this 27th day of April, 2017



MERCHANTS BONDING COMPANY (MUTUAL)  
MERCHANTS NATIONAL BONDING, INC.

By *Larry Taylor*  
President

STATE OF IOWA  
COUNTY OF DALLAS ss.

On this this 27th day of April 2017, before me appeared Larry Taylor, to me personally known, who being by me duly sworn did say that he is President of MERCHANTS BONDING COMPANY (MUTUAL) and MERCHANTS NATIONAL BONDING, INC.; and that the seals affixed to the foregoing instrument are the Corporate Seals of the Companies; and that the said instrument was signed and sealed in behalf of the Companies by authority of their respective Boards of Directors.

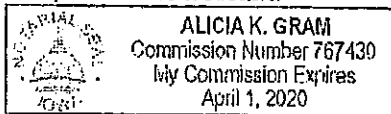

*Alicia K. Gram*  
Notary Public

(Expiration of notary's commission does not invalidate this instrument)

I, William Warner, Jr., Secretary of MERCHANTS BONDING COMPANY (MUTUAL) and MERCHANTS NATIONAL BONDING, INC., do hereby certify that the above and foregoing is a true and correct copy of the POWER-OF-ATTORNEY executed by said Companies, which is still in full force and effect and has not been amended or revoked.

In Witness Whereof, I have hereunto set my hand and affixed the seal of the Companies on this 10th day of January, 2018



*William Warner Jr.*  
Secretary



**St. Johns County Board of County Commissioners**

Purchasing Division

December 19, 2017

**ADDENDUM #1**

**To: Prospective Bidders**  
**From: St. Johns County Purchasing Department**

**Subject: Bid No. 18-32, Northwest WTP 20 Inch Water Main Extension**

This Addendum #1 is issued for further respondent's information and is hereby incorporated into the Bid documents. Each respondent will ascertain before submitting a proposal that he/she has received all Addenda. Please return an original copy of this signed Addendum with proposal to the St. Johns County Purchasing Department, Leigh A. Daniels, CPPB; 500 San Sebastian View; St. Augustine, FL 32084.

**Questions:**

1. It appears that gate valves will be required and I would like to submit Flomatic gate valves for consideration. Currently Mueller is the only approved product in the county spec. Is the county willing to consider another option?

**Answer: Flomatic will be accepted as equal as long as Flomatic meets all specifications per the SJCUD Manual of Water, Wastewater, and Reuse Design Standards & Specifications, Part 3.12.2.**

2. Part III, Section 3.12.3, of the St. Johns County Standards and Specification Manual states all valves 16" and larger are to be butterfly valves. Should the 20" Gate Valve shown on sheet 2 of the project plans be a butterfly valve?

**Answer: The 20" Gate Valve is correct. The intent was to use gate valves since this is a main transmission line in close proximity to the WTP.**

**THE BID DUE DATE REMAINS January 10, 2018 AT 2:00 P.M.**

**Acknowledgment**

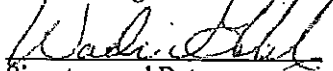
  
Signature and Date

Wade Gibby, President  
Printed Name/Title

G&H Udnerground Construction, inc  
Company Name (Print)

Sincerely,

Leigh A. Daniels, CPPB  
Procurement Supervisor

**END OF ADDENDUM NO. 1**



St. Johns County Board of County Commissioners

Purchasing Division

December 22, 2017

ADDENDUM #2

To: Prospective Bidders  
From: St. Johns County Purchasing Department  
Subject: Bid No. 18-32, Northwest WTP 20 Inch Water Main Extension

This Addendum #1 is issued for further respondent's information and is hereby incorporated into the Bid documents. Each respondent will ascertain before submitting a proposal that he/she has received all Addenda. Please return an original copy of this signed Addendum with proposal to the St. Johns County Purchasing Department, Leigh A. Daniels, CPPB; 500 San Sebastian View; St. Augustine, FL 32084.

Questions:

1. Do the 20" Valves require a gear actuator?

Answer: No, the 20" valves do not require a gear actuator.

2. Does the entire length of the 20" DIP need to be restrained or should we follow the restraint schedule in the details?

Answer: Yes, the ductile iron pipe shall have joint restraint gaskets for the entire length of the project. Please disregard the joint restraint table.

**THE BID DUE DATE REMAINS January 10, 2018 AT 2:00 P.M.**

Acknowledgment

Signature and Date

Wade Gibby, President

Printed Name/Title

G&H Underground Construction, Inc

Company Name (Print)

Sincerely,

Leigh A. Daniels, CPPB  
Procurement Supervisor

**END OF ADDENDUM NO. 2**





**St. Johns County Board of County Commissioners**

Purchasing Division

December 27, 2017

**ADDENDUM #3**

**To: Prospective Bidders**  
**From: St. Johns County Purchasing Department**

**Subject: Bid No. 18-32, Northwest WTP 20 Inch Water Main Extension**

This Addendum #3 is issued for further respondent's information and is hereby incorporated into the Bid documents. Each respondent will ascertain before submitting a proposal that he/she has received all Addenda. Please return an original copy of this signed Addendum with proposal to the St. Johns County Purchasing Department, Leigh A. Daniels, CPPB; 500 San Sebastian View; St. Augustine, FL 32084.

**Questions:**

1. Will an additional 100' overlay be required at the asphalt repair?

**Answer: No, This is a private driveway to the water plant and is not required to have additional 100' overlay. Minimum overlay around the repair would be sufficient.**

**THE BID DUE DATE REMAINS January 10, 2018 AT 2:00 P.M.**

**Acknowledgment,**

A handwritten signature in black ink, appearing to read "Wade Gibby", is written over a horizontal line.

**Signature and Date**

**Wade Gibby, President**  
**Printed Name/Title**

**G&H Underground Construction, Inc**  
**Company Name (Print)**

**Sincerely,**

**Leigh A. Daniels, CPPB**  
**Procurement Supervisor**

**END OF ADDENDUM NO. 3**

**CONSTRUCTORS QUALIFICATION QUESTIONNAIRE  
ORGANIZATION AND BACKGROUND**

Name: G & H Underground Construction Inc.

Address: 2200 N Ponce De Leon Blvd Ste 11 City, State, Zip: St. Augustine, Florida  
32084

Phone: 904-829-8199 Fax: 904-810-0531

Fed I.D.# 06-1747700 Contractors License Number: CUC1224124

Date business formed: May 5, 2005 Date Incorporated: May 5, 2005

**PRINCIPLE OFFICERS OF THE COMPANY**

Name: Wade Gibby  
Position: President / Owner  
% of ownership: 50%  
Experience: 40 years Sup. & GM

Name: Jeffery Hardwick  
Position: Treasurer / Owner  
% of Ownership: 50%  
Experience: 36 years Sup. & GM

**TYPE OF WORK PERFORMED:**

Commercial Roadwork  
Excavation Water System  
Sewers Storm Systems

**GEOGRAPHICAL AREAS OF OPERATION:**

St. Johns County Volusia County  
Duval County Flagler County  
Clay County

**LIST OF MOST RECENT CONTRACTS IN LAST TWELVE YEARS:**

St Johns County Purchasing  
500 San Sebastian View  
St Augustine, Fl .32084

Contract Amount:530,240.00  
June 2017 - Present

Project :Ocean Village Club, Salt  
Water Cowboys, & Seaplace  
Lift Station Upgrades

St Johns County Purchasing  
500 San Sebastian View  
St Augustine, Fl .32084

Contract Amount:476,360.00  
June 2017 - Present

Project: Ponce De Leon Villas,  
Raintree, Anastasia Oaks  
Lift Station Upgrades

Uniflorida IV LLC  
5975 Sunset Drive  
Miami, Fl. 33143

Contract Amount: 1,343,702.90  
March 2017 - Present

Project: Villages of Selo  
y 2B

St Johns County Purchasing  
500 San Sebastian View  
St Augustine, Fl .32084

Contract Amount:304,857.00  
March 2016 - Present

Project: Six Mile 1 Master  
Lift Station

City of St Augustine  
75 King St  
St Augustine, Fl. 32085

Contract Amount: 561,213.72  
February 2017- Present

Project: Davenport Park / County  
Library

St Johns County Purchasing 500 San Sebastian View St Augustine, Fl. 32084	Contract Amount: 191,816.05 November 2016 - Present	Project: Stone Gate Lift Station Improvements
R.B. Gay Construction P.O. Box 3995 Jacksonville, FL 32206 Contact: Alan Reeves	Contract Amount: \$319,623.00 January 2017 - Present Phone: 904-354-8201	Project: 2 <sup>nd</sup> St North Parking Lot Improvements Jacksonville Beach
City of St Augustine 75 King St St Augustine, Fl. 32085	Contract Amount: 267,799.20 July 2016 - January 2017	Project: Pump Station 50-51 Water Main Improvements
City of St Augustine 75 King St St Augustine, Fl. 32085	Contract Amount: 441,611.34 June 2016 - Jan 2017	Project: Sidney Storm Water Improvements
Coastal Contracting 3491 Pall Mall Dr Ste 201 Jacksonville, FL. 32257	Contract Amount: 397,704.51 April 2016 - September 2016	Project: Gates of St Johns
Uniflora IV LLC 5975 Sunset Drive Miami, Fl. 33143	Contract Amount: 1,215,823.20 August 2016 - Present	Project: Villages of Selo 2A
Uniflora IV LLC 5975 Sunset Drive Miami, Fl. 33143	Contract Amount: 265,000 April 2016- Present	Project: Villages of Selo Lift Station 1
St Johns County Purchasing 500 San Sebastian View St Augustine, Fl. 32084	Contract Amount: 294,305.00 April 2016 - Present	Project: Lift Station Imp Osprey & Sawgrass Marriott
Flores Construction Co. 5470 East Busch Blvd #511 Tampa, Fl. 33617	Contract Amount: 280,521.00 March 2016 - Present	Project: City of Jacksonville Beach South Beach Park Pond Removal
City of St Augustine 75 King St St Augustine, Fl. 32085	Contract Amount: 957,551.00 March 2015-November 2015	Project: Magnolia Ave Area Water Main Improvements
Petticoat Schmitt Civil Contractors 6380 Phillips Hwy Jacksonville, Fl. 32216	Contract Amount: 807,729.08 November 2014 - September 2015	Project: Dobbs Rd / Kings Estate Rd.
City of Jacksonville Beach 11 <sup>th</sup> North Third St Jacksonville Beach, Fl. 32250	Contract Amount \$ 3,597,507.20 May 2013 - March 2015	Project: Williams Coastal Blvd Heights & South Beach Infra.

City of St Augustine 75 King St St Augustine, Fl. 32085	Contract Amount \$605,209.98	Project: Abbott Tract Utility Imp.
City of Jacksonville Beach 11 <sup>th</sup> North Third St Jacksonville Beach, Fl. 32250	Contract Amount \$ 865,868.86 February 2014 – January 2015	Project: Phase IIIB Improvements
City of St Augustine 75 King St St Augustine, Fl. 32085	Contract Amount \$169,105.50 April 2014-June 2014	Project: North City Imp Old Mission Ave Water Main
City of Jacksonville Beach 11 North Third St Jacksonville, Fl. 32250	Contract Amount \$521,116.70 June 2012 – May 2013	Project : Duval Drive Roadway & Drainage Improvement
City of Jacksonville Beach 11 <sup>th</sup> North Third St Jacksonville Beach, Fl. 32250	Contract Amount \$ 1,303,131.40 April 2012 – November 2012	Project: Ocean Forest Drainage Improvements
City of St Augustine 75 King St St Augustine, Fl. 32085	Contract Amount: 185,961.00 October 2015-December 2015	Project: Isla Drive Drainage Improvements
City of Atlantic Beach 1200 Sandpiper Lane Atlantic Beach. Fl. 32233	Contract Amount: 91,150.00	Project: Russell Park Multi Purpose Path
City of Atlantic Beach 1200 Sandpiper Lane Atlantic Beach. Fl. 32233	Contract Amount: 380,000.00 April 2015-November 2015	Project: Salt Air Neighborhood Storm Water Improvements
City of St Augustine 75 King St St Augustine, Fl. 32085	Contract Amount \$50,842.00 July 2014 - September 2014	Project: Palmetto Ave City of St Augustine Maintenance
C&D Construction, Inc P.O. Box 236577 Cocoa, Fl. 32923-6577	Contract Amount \$445,369.53	Project: Avenida Menendez Seawall
City of Jacksonville Beach 11 North Third St Jacksonville, Fl. 32250	Contract Amount \$633,010.00	Project : 12 <sup>th</sup> Ave South Erosion Control

City of St Augustine  
75 King St  
St Augustine, Fl. 32084

Contract Amount : \$340,587.01

Project: Palmer St water Main  
Upgrade

City of Jacksonville Beach  
11 North third St  
Jacksonville, Fl. 32250

Contract Amount \$ 171,162.00

Project: Water main Valve  
Rep. Various Locations

City of St Augustine  
75 King St  
St Augustine, Fl. 32084

Contract Amount \$467,990.00

Project: Lincolnville Water Main  
Improvements

City of St Augustine  
75 King St  
St Augustine, Fl. 32084

Contract Amount : \$ 719,080.00  
February 2012-September 2012

Project: Lift Station 51 & 52

City of Jacksonville Beach  
11 North third Street  
Jacksonville, Fl. 32250

Contract Amount : \$532,515.00

Project: Modification to LS # 3

City of St Augustine  
75 King St  
St Augustine, Fl. 32084

Contract Amount : \$ 268,275.00  
December 2011 – February 2012

Project: Storm Water Upgrades

City of Jacksonville Beach  
11 North Third Street  
Jacksonville, FL 32250  
Contact Junior Lilly

Contract Amount: \$455,000.00  
March 2001-February 2012  
Phone: 904-247-6286

Project: Lake Mildred Storm Water  
Pump station

City of Jacksonville Beach  
11 North Third Street  
Jacksonville, FL 32250  
Contact Junior Lilly

Contract Amount: \$455,000.  
Phone: 904-247-6286

Project: 2<sup>nd</sup> & 4<sup>th</sup> Ave North Water  
Main Imp.

City Of St Augustine  
75 King Street  
St Augustine Fl, 32084  
Attn: Marcus Pinson

Contract Amount: \$44,750.00  
Contract Amount: \$55,559.00  
Contract Amount: \$37,391.00  
Marcus Pinson: 904-209-4278

Project: Ribault  
Project: Andreas  
Project: North Matanzas

City Of St Augustine  
75 King Street  
St Augustine Fl, 32084  
Attn: Marcus Pinson

Contract Amount: \$72,000.00  
Phone: 904-209-4278

Project: Pump Station No 2  
Rehabilitation

**St Johns County**  
2446 Dobbs Rd  
System Improvements  
St Augustine, Fl. 32086  
Aaron Zambo

Contract Amount: \$413,953.00  
November 2009-November 2010

Project: Sevilla Gardens  
Sewer

Phone: 904-209-2628

**St Johns County**  
2446 Dobbs Rd  
St Augustine, Fl. 32086  
Aaron Zambo

Contract Amount: \$838,393.40  
November 2009-November 2010

Project: Woodland West  
Subdivision . Sewer System Imp.

Phone: 904-260-6288

**City Of Palatka**  
201 North 2<sup>nd</sup> St  
Palatka, Fl. 32177  
Daryl Myers

Contract Amount: \$819,419.72  
October 2009-May 2010

Project: Dunham Street Water Main  
Extension

Phone: 904-260-6288

**Pat Cook Construction**  
1904 Manatee Ave W #300  
Bradenton, FL 34205  
Mark Coyne

Contract Amount: \$100,650.00

Project: Wards Creek &  
Timberlin Creek Elementary  
Sewer/Gravity

Phone: 941-749-1959

**City of Atlantic Beach**

Project  
800 Seminole Road  
Atlantic Beach, FL 32233  
Contact: Rick Carper

Contract Amount: \$39,252.68

Project: George Street Sidewalk  
and Drainage CDBG

Phone: 904-247-5834

**St. Johns County BOCC**  
2740 Industry Center Road  
St. Augustine, FL 32084  
Contact Joan Anderson

Contract Amount: \$195,011.00

Project: Shores Blvd  
Pipe Replacement

Phone: 904-209-0128

**St. Johns County BOCC**  
1205 SR 16  
Main Improvements  
St. Augustine, FL 32084  
Contact Robert Zammataro, PE

Contract Amount: \$490,761.98  
February 2009-October 2009

Project: Treasure Beach  
Water

Phone: 904-209-2604

**City of St. Augustine**  
P.O. Box 210  
St. Augustine, FL 32085  
Contact: Paul Spangler

Contract Amount: \$21,529.00

Project: Pump Station  
23 Repairs

Phone: 904-825-1042

**City of Jacksonville Beach**  
11 North Third Street  
Jacksonville, FL 32250  
Contact Junior Lilly

Contract Amount: \$1,519,325.95

Project: Infrastructure  
Improvements Parts A, B & C

Phone: 904-247-6286

**R.B. Gay Construction**  
P.O. Box 3995  
Jacksonville, FL 32206  
Contact: Alan Reeves

Contract Amount: \$778,727.87  
December 2005-December 2006

Project: EOC

Phone: 904-354-8201

**Ruggeri Construction**  
815 S.R. 206 East  
St. Augustine, FL 32086

Contract Amount: \$156,960.00

Project: Forest Oaks

Phone: 904-797-0201

**Halifax Paving**  
P.O. Box 730549  
Ormond Beach, FL 32173  
Contact: Ruth

Contract Amount: \$ 2,350,000  
December 2005-December 2006

Project: Conservatory

**PCI**  
3702 Olson Drive  
Daytona Beach, FL 32124  
Contact: Cathy Cobb

Contract Amount: \$ 1,070,000  
August 2006-June 2007

Project: Old Kings Road  
Tymer Creek

Phone: 386-258-3807

**R.B. Gay Construction**  
P.O. Box 3995  
Jacksonville, FL 32206  
Contact: George Durance

Contract Amount: \$ 1,010,000

Project: St. Johns Co. Fire &  
Rescue

Phone: 904-354-8201

**Cats Paw Marina**  
220 Nix Boat Yard Rd.  
St. Augustine, FL 32086  
Contact: Sonya Jenson

Contract Amount: \$ 327,000  
May 2007-November 2007

Project: Cats Paw Marina

Phone: 904-829-0840

**Lucas Marine**  
1100 Shelter Ave.  
Jacksonville, FL 32250  
Contact: Frank Subjenski

Contract Amount: \$ 172,400

Project: FLA # \*8 Shoreline

Phone: 904-246-6017

**Largest work on-hand position of company, at any one time was \$ 2,500,000**

**ADDITIONAL REFERENCES:**

**Dennis Deprise**  
11 North Third St  
City of Jacksonville Beach  
Jacksonville Beach, 32250  
Email : [ddupries@jaxbchfl.net](mailto:ddupries@jaxbchfl.net)  
904-247-6286

**Bill Mendez**

**City of St Augustine**  
75 King St  
St Augustine, Fl. 32085  
Email: [bmendez@citystaug.com](mailto:bmendez@citystaug.com)  
904-825-1040

**Rueben Franklin**  
City of St Augustine  
75 King St  
St Augustine, Fl. 32085  
Email: [rfranklin@citystaug.com](mailto:rfranklin@citystaug.com)  
904-209-4279

**Marcus Pinson**  
City of St Augustine  
75 King St  
St Augustine, Fl. 32085  
Email: [mpinson@citystaug.com](mailto:mpinson@citystaug.com)  
904-823-2204

**Brian Hepburn**  
Edmunds & Associates  
1100 Cesery Terrace  
Jacksonville, Fl. 32211  
Email: [bhepburn@jonesedmunds.com](mailto:bhepburn@jonesedmunds.com)  
904-744-5401

**Tom Moore**  
GAI Consultants  
1301 Riverplace Blvd Suite 900  
Jacksonville, Fl. 32207  
Email: [t.moore@gaiconsultants.com](mailto:t.moore@gaiconsultants.com)  
904-363-1110

**John Moye**  
Waitz & Moye  
3738 Southside Blvd #101  
Jacksonville, Fl. 32216

**Mike Adams**  
St Johns County Project Administrator  
Email: [madams@sjcfl.us](mailto:madams@sjcfl.us)  
904-209-0655



**ST. JOHNS COUNTY  
BID TABULATION**

*Handwritten initials*

**BID TITLE** NORTHWEST WTP 20 INCH WATER MAIN EXTENSION

ANY BIDDER AFFECTED ADVERSELY BY AN INTENDED  
DECISION WITH RESPECT TO THE AWARD OF ANY BID,  
SHALL FILE WITH THE PURCHASING DEPARTMENT FOR  
ST. JOHNS COUNTY, A WRITTEN NOTICE OF INTENT  
FILE A PROTEST NOT LATER THAN SEVENTY-TWO (72)  
HOURS (EXCLUDING SATURDAY, SUNDAY AND LEGAL  
HOLIDAYS) AFTER THE POSTING OF THE BID TABULATION  
PROTEST PROCEDURES MAY BE OBTAINED IN THE  
PURCHASING DEPARTMENT.

**OPENED BY**  
**TABULATED BY**  
**VERIFIED BY**

LEIGH DANIELS  
BRYAN MATUS

**BID NUMBER** 18-32

**OPENING DATE/TIME** January 10, 2018 2:00 PM

**POSTING DATE/TIME**

<u>FROM</u>	<u>UNTIL</u>
01/10/18	01/16/18
4:30 PM	4:30 PM

BIDDERS	TOTAL LUMP SUM BID	BID BOND	ADDENDUM # 1	ADDENDUM # 2	ADDENDUM # 3		
CROSSROADS SITE DEVELOPMENT, LLC	\$248,499.00	YES	YES	YES	YES		
KIRBY DEVELOPMENT, INC	\$252,267.00	YES	YES	YES	YES		
PETTICOAT-SCHMITT CIVIL CONTRACTORS, INC.	\$305,640.00	YES	YES	YES	YES		
DNS CONTRACTING LLC	\$228,500.00	YES	YES	YES	YES		
4C'S TRUCKING & EXCAVATION, INC.	\$216,885.42	YES	YES	YES	YES		
J.B. COXWELL CONTRACTING, INC.	\$232,526.00	YES	YES	YES	YES		

BID AWARD DATE - \_\_\_\_\_

**ST. JOHNS COUNTY  
BID TABULATION**

**BID TITLE**

NORTHWEST WTP 20 INCH WATER MAIN EXTENSION

ANY BIDDER AFFECTED ADVERSELY BY AN INTENDED  
DECISION WITH RESPECT TO THE AWARD OF ANY BID,

**OPENED BY**  
**TABULATED BY**  
**VERIFIED BY**

LEIGH DANIELS  
BRYAN MATUS

**BID NUMBER**

18-32

SHALL FILE WITH THE PURCHASING DEPARTMENT FOR  
ST. JOHNS COUNTY, A WRITTEN NOTICE OF INTENT

**OPENING DATE/TIME**

January 10, 2018      2:00 PM

FILE A PROTEST NOT LATER THAN SEVENTY-TWO (72)  
HOURS (EXCLUDING SATURDAY, SUNDAY AND LEGAL

**POSTING DATE/TIME**

<u>FROM</u>	<u>UNTIL</u>
<u>01/10/18</u>	<u>01/16/18</u>
<u>4:30 PM</u>	<u>4:30 PM</u>

HOLIDAYS) AFTER THE POSTING OF THE BID TABULATION  
PROTEST PROCEDURES MAY BE OBTAINED IN THE  
PURCHASING DEPARTMENT.

PAGE(S) 2 of 3

BIDDERS	TOTAL LUMP SUM BID	BID BOND	ADDENDUM # 1	ADDENDUM # 2	ADDENDUM # 3		
SAWCROSS, INC	\$243,850.00	YES	YES	YES	YES		
T.G. UTILITY COMPANY, INC	\$242,746.70	YES	YES	YES	YES		
THEKENTON GROUP/BALDWINS	\$214,800.00	YES	YES	YES	YES		
T B LANDMARK CONSTRUCTION, INC	\$233,333.00	YES	YES	YES	YES		
G&H UNDERGROUND CONSTRUCTION, INC	\$222,020.00	YES	YES	YES	YES		
DB CIVIL CONSTRUCTION, LLC	\$225,782.50	YES	YES	YES	YES		

BID AWARD DATE - \_\_\_\_\_

**ST. JOHNS COUNTY  
BID TABULATION**

*JAD*  
LEIGH DANIELS  
BRYAN MATUS

**BID TITLE**

NORTHWEST WTP 20 INCH WATER MAIN EXTENSION

ANY BIDDER AFFECTED ADVERSELY BY AN INTENDED  
DECISION WITH RESPECT TO THE AWARD OF ANY BID,

**OPENED BY**  
**TABULATED BY**  
**VERIFIED BY**

**BID NUMBER**

18-32

SHALL FILE WITH THE PURCHASING DEPARTMENT FOR  
ST. JOHNS COUNTY, A WRITTEN NOTICE OF INTENT

**OPENING DATE/TIME**

January 10, 2018 - 2:00 PM

FILE A PROTEST NOT LATER THAN SEVENTY-TWO (72)  
HOURS (EXCLUDING SATURDAY, SUNDAY AND LEGAL

**POSTING DATE/TIME**

FROM	UNTIL
<u>01/10/18</u>	<u>01/16/18</u>
<u>4:30 PM</u>	<u>4:30 PM</u>

HOLIDAYS) AFTER THE POSTING OF THE BID TABULATION  
PROTEST PROCEDURES MAY BE OBTAINED IN THE  
PURCHASING DEPARTMENT.

PAGE (S) 3 of 3

BIDDERS	TOTAL LUMP SUM BID	BID BOND	ADDENDUM # 1	ADDENDUM # 2	ADDENDUM # 3		
J.B. HINSON COMPANY	\$295,427.18	YES	YES	YES	YES		
S.E. CLINE CONSTRUCTION, INC	\$233,975.00	YES	YES	YES	YES		

BID AWARD DATE - \_\_\_\_\_



**St. Johns County Board of County Commissioners**

Purchasing Division

December 27, 2017

**ADDENDUM #3**

**To: Prospective Bidders**  
**From: St. Johns County Purchasing Department**

**Subject: Bid No. 18-32, Northwest WTP 20 Inch Water Main Extension**

This Addendum #3 is issued for further respondent's information and is hereby incorporated into the Bid documents. Each respondent will ascertain before submitting a proposal that he/she has received all Addenda. **Please return an original copy of this signed Addendum with proposal to the St. Johns County Purchasing Department, Leigh A. Daniels, CPPB; 500 San Sebastian View; St. Augustine, FL 32084.**

**Questions:**

1. Will an additional 100' overlay be required at the asphalt repair?

**Answer: No, This is a private driveway to the water plant and is not required to have additional 100' overlay. Minimum overlay around the repair would be sufficient.**

**THE BID DUE DATE REMAINS January 10, 2018 AT 2:00 P.M.**

**Acknowledgment**

**Sincerely,**

\_\_\_\_\_  
Signature and Date

Leigh A. Daniels, CPPB  
Procurement Supervisor

\_\_\_\_\_  
Printed Name/Title

\_\_\_\_\_  
Company Name (Print)

**END OF ADDENDUM NO. 3**



**St. Johns County Board of County Commissioners**

Purchasing Division

December 22, 2017

**ADDENDUM #2**

**To: Prospective Bidders**  
**From: St. Johns County Purchasing Department**

**Subject: Bid No. 18-32, Northwest WTP 20 Inch Water Main Extension**

This Addendum #1 is issued for further respondent's information and is hereby incorporated into the Bid documents. Each respondent will ascertain before submitting a proposal that he/she has received all Addenda. **Please return an original copy of this signed Addendum with proposal to the St. Johns County Purchasing Department, Leigh A. Daniels, CPPB; 500 San Sebastian View; St. Augustine, FL 32084.**

**Questions:**

1. Do the 20" Valves require a gear actuator?

**Answer: No, the 20" valves do not require a gear actuator.**

2. Does the entire length of the 20" DIP need to be restrained or should we follow the restraint schedule in the details?

**Answer: Yes, the ductile iron pipe shall have joint restraint gaskets for the entire length of the project. Please disregard the joint restraint table.**

**THE BID DUE DATE REMAINS January 10, 2018 AT 2:00 P.M.**

**Acknowledgment**

**Sincerely,**

\_\_\_\_\_  
Signature and Date

Leigh A. Daniels, CPPB  
Procurement Supervisor

\_\_\_\_\_  
Printed Name/Title

\_\_\_\_\_  
Company Name (Print)

**END OF ADDENDUM NO. 1**

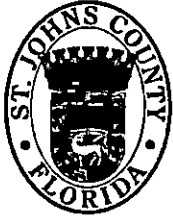

**St. Johns County Board of County Commissioners**

Purchasing Division

December 19, 2017

**ADDENDUM #1**

**To: Prospective Bidders**  
**From: St. Johns County Purchasing Department**

**Subject: Bid No. 18-32, Northwest WTP 20 Inch Water Main Extension**

This Addendum #1 is issued for further respondent's information and is hereby incorporated into the Bid documents. Each respondent will ascertain before submitting a proposal that he/she has received all Addenda. **Please return an original copy of this signed Addendum with proposal to the St. Johns County Purchasing Department, Leigh A. Daniels, CPPB; 500 San Sebastian View; St. Augustine, FL 32084.**

**Questions:**

- 1. It appears that gate valves will be required and I would like to submit Flomatic gate valves for consideration. Currently Mueller is the only approved product in the county spec. Is the county willing to consider another option?

**Answer: Flomatic will be accepted as equal as long as Flomatic meets all specifications per the SJCUD Manual of Water, Wastewater, and Reuse Design Standards & Specifications, Part 3.12.2.**

- 2. Part III, Section 3.12.3, of the St. Johns County Standards and Specification Manual states all valves 16" and larger are to be butterfly valves. Should the 20" Gate Valve shown on sheet 2 of the project plans be a butterfly valve?

**Answer: The 20" Gate Valve is correct. The intent was to use gate valves since this is a main transmission line in close proximity to the WTP.**

**THE BID DUE DATE REMAINS January 10, 2018 AT 2:00 P.M.**

**Acknowledgment**

**Sincerely,**

\_\_\_\_\_  
Signature and Date

Leigh A. Daniels, CPPB  
Procurement Supervisor

\_\_\_\_\_  
Printed Name/Title

\_\_\_\_\_  
Company Name (Print)

**END OF ADDENDUM NO. 1.**

# NORTHWEST WTP 20-IN WATER MAIN EXTENSION

FOR

ST. JOHNS COUNTY UTILITY DEPARTMENT

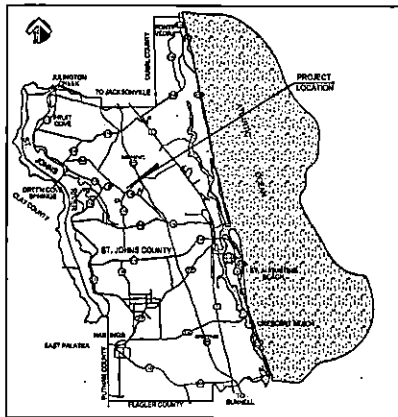

LOCATION MAP



UTILITIES

## TABLE OF CONTENTS

<u>SHEET NO.</u>	<u>DESCRIPTION</u>
	COVER SHEET
1	GENERAL NOTES (GN-1)
2	UTILITY SITE PLAN - STA. 0+00 TO STA. 6+50
3	UTILITY SITE PLAN - STA. 5+50 TO STA. 10+75
4	SJUCUD STANDARD WATER DETAILS
5	MISCELLANEOUS DETAILS

ST. JOHNS COUNTY UTILITY DEPARTMENT  
1205 STATE ROAD 16  
ST. AUGUSTINE, FL 32084  
(904) 209-2700

## CONSTRUCTION PLANS

SEPTEMBER 2017

ST. JOHNS COUNTY UTILITY DEPARTMENT (SJCUD) GENERAL NOTES



ST. JOHNS COUNTY UTILITY DEPARTMENT
1205 STATE ROAD 18
ST. AUGUSTINE, FLORIDA 32084
Phone (904) 209-2700

DATE: 9/29/17
DESIGNED BY: JAO
DRAWN BY: JAO
CHECKED BY: JAO
SCALE: AS SHOWN

AMENDMENTS

NORTHWEST WTP 20-IN WATER MAIN EXTENSION
GENERAL NOTES

SHEET NO. 1
OF 5

GENERAL:

- 1. TWO (2) COPIES OF THE SHOP DRAWINGS STAMPED APPROVED BY THE...
2. A PRE-CONSTRUCTION CONFERENCE IS REQUIRED WITH THE DEVELOPER...
3. FITTINGS SHALL BE USED AT LOCATIONS INDICATED ON THE PLANS...
4. THE CONTRACTOR IS RESPONSIBLE FOR INSPECTING THE SITE PRIOR TO CONSTRUCTION...
5. THE CONTRACTOR SHALL BE RESPONSIBLE FOR FIELD VERIFICATION OF ALL LOCATIONS & ELEVATIONS PRIOR TO COMMENCEMENT OF CONSTRUCTION...
6. THE CONTRACTOR(S) SHALL LOCATE, VERIFY, AND IDENTIFY ALL EXISTING UTILITIES AND UNDERGROUND UTILITIES SHOWN OR NOT SHOWN ON THE PLANS...
7. THE WATER, SEWER, AND/OR REUSE SYSTEM SHALL BE CONSTRUCTED IN ACCORDANCE WITH THE SJCUD APPROVED CONSTRUCTION DRAWINGS AND SPECIFICATIONS...
8. THE CONTRACTOR SHALL FIELD VERIFY THE CONNECTION POINTS PRIOR TO THE COMMENCEMENT OF CONSTRUCTION...
9. EXISTING UTILITIES SHOWN ON THESE PLANS HAVE BEEN LOCATED FOR POSSIBLE REPAIRS WITHOUT EXCAVATION...
10. VERTICAL LOCATIONS OF ALL UTILITIES (INCLUDING EXISTING STORM SEWERS) SHOWN ON PLANS AND UTILITY SHEETS HAVE BEEN REFERENCED TO A BENCH MARK SYSTEM ON THE SITE...
11. SHOULD CONDITIONS VARY FROM THOSE SHOWN ON THESE PLANS, THE CONTRACTOR SHALL IMMEDIATELY NOTIFY THE ENGINEER AND SJCUD PRIOR TO CONTINUING CONSTRUCTION...
12. THE CONTRACTOR SHALL PROTECT SURVEY MARKS, MONUMENTS, ETC. DURING CONSTRUCTION...
13. THE CONTRACTOR SHALL BE RESPONSIBLE FOR ANY DAMAGE TO EXISTING UTILITIES CAUSED BY HIS OPERATIONS...
14. THE CONTRACTOR SHALL COORDINATE ALL CONSTRUCTION AND BUILDING PLACEMENT WITH ALL OTHER UTILITIES CONSTRUCTION...
15. THE CONTRACTOR SHALL BE RESPONSIBLE FOR REMOVAL AND DISPOSAL OF ANY UNSALVAGEABLE MATERIAL...
16. UNSALVAGEABLE MATERIALS UNDER WATER, SEWER, AND/OR REUSE MAINS SHALL BE REMOVED AND REPLACED WITH SELECTED BACKFILL...
17. THE CONTRACTOR(S) SHALL NOTIFY ALL APPLICABLE UTILITY COMPANIES...
18. THE ENGINEER OF RECORD AND SJCUD SHALL BE GIVEN SEVENTY TWO HOURS...
19. ALL WORK, MATERIALS, AND EQUIPMENT SHALL BE IN COMPLETE ACCORDANCE...
20. ALL UNDERGROUND UTILITY EQUIPMENT, MATERIALS AND INSTALLATION SHALL BE IN ACCORDANCE WITH THE MANUAL OF WATER, WASTEWATER, AND REUSE DESIGN STANDARDS...
21. ALL UTILITY CROSSINGS SHALL COMPLY WITH FDEP REGULATIONS...
22. ANY LANDSCAPING TREES SHALL BE PLACED AT A MINIMUM OF 7.5 FEET AWAY FROM THE EDGE OF PAVEMENT TO THE EDGE OF THE TREE LINE...
23. ALL ROCK AND UNSALVAGEABLE SIZE STONES (AS DESCRIBED IN APPLICABLE ANNA AND ST. JOHNS COUNTY UTILITIES STANDARD SPECIFICATIONS...)

- 24. FOR WATER, WASTEWATER, AND REUSE MAINS SMALLER THAN 12 INCHES...
25. SANITARY SEWER LINES TO DEPTHS OF 10' SHALL BE 300-33 PVC PIPE...
26. FITTINGS SHALL BE USED AT LOCATIONS INDICATED ON THE PLANS...
27. ALL UNDERGROUND VALVES SHALL BE INSTALLED WITH AN ADJUSTABLE CAST IRON Yoke END WITH TOP SET TO FINAL GRADE...
28. CONTRACTOR IS RESPONSIBLE FOR PROPER NOTIFICATION OF INSPECTING AUTHORITIES BEFORE AND DURING CONSTRUCTION...
29. CONTRACTOR SHALL PROVIDE A MINIMUM OF SEVEN (7) CALENDAR DAYS NOTICE TO SJCUD PRIOR TO SCHEDULING THE FINAL INSPECTION...

NOTICE OF PROCEDURE:

- 1. ALL COMMERCIAL BUILDING PERMITS AND METERS PROCESSED THROUGH SJCUD...
2. ALL CONNECTIONS TO THE WATER, SEWER, AND/OR REUSE SYSTEM, FLOODING, AND PRESSURE TESTS TO BE PERFORMED BY THE UTILITY CONTRACTOR...
3. IT IS THE ENGINEER'S RESPONSIBILITY TO SECURE APPLICABLE PERMITS PRIOR TO CONSTRUCTION...
4. THE PROPERTY OWNER SHALL PURCHASE THE WATER METER THROUGH THE SJCUD...
5. WATER, SEWER, AND/OR REUSE UTILITY CONNECTION FEES SHALL BE PAID AT THE TIME OF BUILDING PERMIT APPLICATION...
6. ALL ON-SITE PRIVATE WATER, SEWER, AND/OR REUSE CONSTRUCTION BETWEEN THE METER AND BUILDING SHALL BE INSPECTED BY THE SJCUD TO DISBURSE STANDARDS ARE MET...
7. ALL REQUIREMENTS BY THE SJCUD (IE, FINAL INSPECTION, CONNECTION OF PUMP OUT ITEMS, OR QUALITY CONTROL OF CONSTRUCTION, ETC) MUST BE SATISFIED PRIOR TO SIGNATURE OF CERTIFICATE OF COMPLETION...

POTABLE WATER SYSTEMS NOTES:

- 1. ALL WATER MAINS 4" THROUGH 12" DIAMETER SHALL BE PVC C-1000, DR-18, COLOR 'TALE' WITH PUSH-ON GASKETED JOINTS OR C-908 HOPE OR 11 COLOR 'TALE' OR OF CLASS 350...
2. ALL WATER MAINS 16" THROUGH 20" DIAMETER SHALL BE PVC C-905, DR-18, COLOR 'TALE' WITH PUSH-ON GASKETED JOINTS OR C-908 HOPE OR 11 COLOR 'TALE' OR OF CLASS 350...
3. ALL WATER MAINS 24" AND LARGER DIAMETER SHALL BE DUCTILE IRON PIPE...
4. ALL WATER LINES 2" DIAMETER OR LESS SHALL BE HDPE CTS OR 8 COLOR 'TALE'...
5. ALL CURB STOPS ARE TO BE FORD BALL-TYPE OR EQUAL WITH LOCKING CAPACITY, 1" NOMINAL...
6. THE SEPARATION REQUIREMENT BETWEEN POTABLE WATER MAINS AND OTHER UTILITIES SHALL BE PER CH. 62-555.040, F.A.C...
7. A FULL UNCUT LENGTH OF WATER MAIN PIPE (USUALLY 20 FEET) SHALL BE OBTAINED AT THE POINT OF CROSSING OF ALL WATER AND SEWER (INCLUDING STORM) LINES AT THE POINT OF CROSSING'S REGARDS OF THE VERTICAL SEPARATION...
8. WHERE SOLVENT CONTAMINATION IS FOUND IN THE TRENCH, WORK WILL BE STOPPED AND THE PROPER AUTHORITIES NOTIFIED...
9. NO CONNECTION TO EXISTING POTABLE WATER SYSTEM SHALL BE ALLOWED UNLESS ALL PROPOSED WATER LINES HAVE BEEN PRESSURE TESTED, DEWATERED, CLEANED FOR SERVICE AND ACCEPTED FOR MAINTENANCE BY THE SJCUD AND PEP...
10. JACKETED CONNECTIONS WITH BACKFLOW PREVENTION DEVICE SHALL BE USED TO FULL ON FLOOD WATER MAINS...
11. ALL NEW AND RELOCATED WATER MAIN PIPE, FITTINGS, VALVES, AND FIRM HYDRANTS SHALL BE IN CONFORMANCE WITH APPLICABLE AMERICAN WATER WORKS ASSOCIATION (AWWA) AND SJCUD STANDARDS...
12. ALL NEW AND RELOCATED WATER MAINS SHALL BE IDENTIFIED IN ACCORDANCE WITH AWWA STANDARD C901 AND RULE 62-555.040, F.A.C...
13. ALL NEW AND RELOCATED WATER MAINS SHALL BE IN CONFORMANCE WITH THE STATE PLUMBING CODE...
14. THE CATHEODOLICAL SAMPLE POINTS SHALL BE INDICATED ON THE AS BUILT DRAWINGS...
15. ALL NEW AND RELOCATED WATER MAINS SHALL BE PRESSURE TESTED AND LEAKAGE TESTED IN ACCORDANCE WITH AWWA STANDARD C901, LATEST EDITION...

WASTEWATER SYSTEM NOTES:

- 1. INTERIOR LINES ARE REQUIRED ON ANCHORAGE MANHOLE WITH THREE OR MORE BRANCHES...
2. SANITARY SEWER LINES TO DEPTHS OF 10' SHALL BE 300-33 PVC PIPE...
3. SANITARY SEWER FORCE MAIN 4" AND LARGER SHALL BE C900 33 PVC PIPE...
4. THE CONTRACTOR SHALL SUBMIT TO THE ENGINEER OF RECORD AND SJCUD ALL WELD LOGS, WRITTEN REPORTS, AND COLLECTION TEST RESULTS FOR REVIEW AND APPROVAL...
5. THE CONTRACTOR SHALL CONTACT SJCUD PRE-TREATMENT DEPARTMENT AT (904) 471-8489 EXT. 223 FOR INSPECTION AFTER INSTALLATION OF GREASE TRAPS, INTERCEPTORS, AND/OR OIL-WATER SEPARATORS...

AS-BUILTS:

- 1. IT SHALL BE THE CONTRACTOR'S RESPONSIBILITY TO PROVIDE, SUBMIT AND OBTAIN APPROVAL OF REPRODUCIBLE 'AS-BUILT' DRAWINGS FROM DISSEMINATIONAL ADDRESSES AS MAY BE REQUIRED...
2. 'AS-BUILT' INFORMATION SHALL BE THE RESPONSIBILITY OF THE CONTRACTOR...
3. A MINIMUM OF FIVE WORKING DAYS PRIOR TO THE FINAL INSPECTION...
4. THE RECORD OR 'AS-BUILT' DRAWINGS TO BE PREPARED BY THE CONTRACTOR AND SUBMITTED AT THE TIME OF THE REQUEST FOR A LETTER OF RELEASE...
5. AFTER SJCUD HAS APPROVED PRELIMINARY 'AS-BUILT', THREE (3) SETS OF READING 'AS-BUILTS' (SIGNED AND SEALED) ONE SET OF PRINTS AS BUILT (SIGNED) AND COPY OF RECORD SHALL BE SUBMITTED TO SJCUD...
6. THE RECORD OR 'AS-BUILT' DRAWINGS TO BE PREPARED BY THE CONTRACTOR AND SUBMITTED AT THE TIME OF THE REQUEST FOR A LETTER OF RELEASE...
7. THE RECORD OR 'AS-BUILT' DRAWINGS TO BE PREPARED BY THE CONTRACTOR AND SUBMITTED AT THE TIME OF THE REQUEST FOR A LETTER OF RELEASE...

STANDARD WATER/SEWER/RECLAIMED WATER SEPARATION STATEMENT:

- 1. THE CONTRACTOR SHALL INSTALL ALL MAINS IN ACCORDANCE WITH THE REQUIREMENTS OF RULE 62-555.314, F.A.C...
2. FOR THE PURPOSE OF THIS SECTION, THE PHRASE 'WATER MAIN' SHALL MEAN MAINS INCLUDING TREATMENT PLANT PROCESS PIPING...
3. HORIZONTAL SEPARATION BETWEEN UNDERGROUND WATER MAINS AND SANITARY OR STORM SEWERS, WASTEWATER OR STORMWATER FORCE MAINS, RECLAIMED WATER PIPELINES, AND ON-SITE SEWAGE TREATMENT AND DISPOSAL SYSTEMS...
4. NEW OR RELOCATED UNDERGROUND WATER MAINS SHALL BE LAID TO PROVIDE A HORIZONTAL DISTANCE OF AT LEAST THREE FEET BETWEEN THE OUTSIDE OF THE WATER MAIN AND THE OUTSIDE OF ANY EXISTING OR PROPOSED STORM SEWER, STORMWATER FORCE MAIN, OR PIPELINE...
5. NEW OR RELOCATED UNDERGROUND WATER MAINS SHALL BE LAID TO PROVIDE A HORIZONTAL DISTANCE OF AT LEAST THREE FEET, AND PREFERABLY TEN FEET, BETWEEN THE OUTSIDE OF THE WATER MAIN AND THE OUTSIDE OF ANY EXISTING OR PROPOSED GRAVITY OR PRESSURE-TYPE SANITARY SEWER, WASTEWATER FORCE MAIN, OR PIPELINE...
6. NEW OR RELOCATED UNDERGROUND WATER MAINS SHALL BE LAID TO PROVIDE A HORIZONTAL DISTANCE OF AT LEAST THREE FEET, AND PREFERABLY TEN FEET, BETWEEN THE OUTSIDE OF THE WATER MAIN AND THE OUTSIDE OF ANY EXISTING OR PROPOSED GRAVITY OR PRESSURE-TYPE SANITARY SEWER, WASTEWATER FORCE MAIN, OR PIPELINE...
7. VERTICAL SEPARATION BETWEEN UNDERGROUND WATER MAINS AND SANITARY OR STORM SEWERS, WASTEWATER OR STORMWATER FORCE MAINS, AND RECLAIMED WATER PIPELINES...
8. NEW OR RELOCATED UNDERGROUND WATER MAINS CROSSING ANY EXISTING OR PROPOSED GRAVITY OR PRESSURE-TYPE SANITARY SEWER OR STORM SEWER SHALL BE LAID TO PROVIDE A HORIZONTAL DISTANCE OF AT LEAST TEN FEET BETWEEN THE OUTSIDE OF THE WATER MAIN AND ALL PARTS OF ANY EXISTING OR PROPOSED ON-SITE SEWER TREATMENT AND DISPOSAL SYSTEMS...
9. NEW OR RELOCATED UNDERGROUND WATER MAINS CROSSING ANY EXISTING OR PROPOSED PRESSURE-TYPE SANITARY SEWER, WASTEWATER OR STORMWATER FORCE MAIN, OR PIPELINE...
10. NEW OR RELOCATED UNDERGROUND WATER MAINS SHALL BE LAID TO PROVIDE A HORIZONTAL DISTANCE OF AT LEAST TEN FEET BETWEEN THE OUTSIDE OF THE WATER MAIN AND ALL PARTS OF ANY EXISTING OR PROPOSED ON-SITE SEWER TREATMENT AND DISPOSAL SYSTEMS...

- (C) AT THE UTILITY CROSSINGS DESCRIBED IN PARAGRAPHS (A) AND (B) ABOVE, THE FULL LENGTH OF WATER MAIN PIPE SHALL BE CENTERED ABOVE OR BELOW THE OTHER PIPELINE...
(3) SEPARATION BETWEEN WATER MAINS AND SANITARY OR STORM SEWER MANHOLES...
(A) NO WATER MAIN SHALL PASS THROUGH, OR COME INTO CONTACT WITH, ANY PART OF A SANITARY SEWER MANHOLE...
(B) EFFECTIVE AUGUST 29, 2004, WATER MAINS SHALL NOT BE CONSTRUCTED OR ALLOWED TO PASS THROUGH OR COME INTO CONTACT WITH ANY PART OF A STORM SEWER MANHOLE OR BEST STRUCTURE...
(3) SEPARATION BETWEEN WATER MAINS AND SANITARY OR STORM SEWER MANHOLES...
(A) NO WATER MAIN SHALL PASS THROUGH, OR COME INTO CONTACT WITH, ANY PART OF A SANITARY SEWER MANHOLE...
(B) EFFECTIVE AUGUST 29, 2004, WATER MAINS SHALL NOT BE CONSTRUCTED OR ALLOWED TO PASS THROUGH OR COME INTO CONTACT WITH ANY PART OF A STORM SEWER MANHOLE...

- 1. TECHNICAL OR ECONOMIC JUSTIFICATION FOR EACH CONFLICT MANHOLE...
2. A STATEMENT IDENTIFYING THE PARTY RESPONSIBLE FOR MAINTAINING EACH CONFLICT MANHOLE...
3. EVIDENCE OF COMPLIANCE WITH THE DESIGN AND CONSTRUCTION REQUIREMENTS IN SUB-PARAGRAPHS A THROUGH D, BELOW...
A. EACH WATER MAIN PASSING THROUGH A CONFLICT MANHOLE SHALL HAVE A FLEXIBLE MANHOLES JOINT ON EACH SIDE OF THE MANHOLE TO ACCOMMODATE DIFFERENTIAL SETTLEMENT BETWEEN THE MAIN AND THE MANHOLE...
B. WITHIN EACH CONFLICT MANHOLE, THE WATER MAIN PASSING THROUGH THE MANHOLE SHALL BE INSTALLED IN A WATER-TIGHT CASING PIPE HAVING HIGH IMPACT STRENGTH...
C. EACH CONFLICT MANHOLE SHALL HAVE AN ACCESS OPENING, AND SHALL BE SIZED TO ALLOW FOR EASY CLEANING OF THE WORK AREA...
D. GRATES SHALL BE INSTALLED AT ALL STORM SEWER MAINS UPSTREAM OF EACH CONFLICT MANHOLE TO PREVENT LARGE OBJECTS FROM ENTERING THE MANHOLE...
(E) SEPARATION BETWEEN FIRE HYDRANT MAINS AND SANITARY OR STORM SEWER, WASTEWATER OR STORMWATER FORCE MAINS, RECLAIMED WATER PIPELINES, AND ON-SITE SEWAGE TREATMENT AND DISPOSAL SYSTEMS, NEW OR RELOCATED FIRE HYDRANTS WITH UNDERGROUND DRINKS SHALL BE LOCATED SO THAT THE DRINKS ARE AT LEAST THREE FEET FROM ANY EXISTING OR PROPOSED STORM SEWER, STORMWATER FORCE MAIN, OR PIPELINE...
(F) SANITARY SEWER MAINS SHALL BE LOCATED AT LEAST SIX FEET FROM ANY EXISTING OR PROPOSED GRAVITY OR PRESSURE-TYPE SANITARY SEWER, WASTEWATER FORCE MAIN, OR PIPELINE...
(G) EXCEPTIONS, WHERE IT IS NOT TECHNICALLY FEASIBLE OR ECONOMICALLY DEPENDABLE TO COMPLY WITH THE REQUIREMENTS IN SUBSECTION (1) OR (2) ABOVE, THE CONTRACTOR SHALL ALLOW EXCEPTIONS TO THESE REQUIREMENTS...
(1) USE OF PRESSURE-TESTED PIPE CONFORMING TO THE AMERICAN WATER WORKS ASSOCIATION STANDARDS INCORPORATED INTO RULE 62-555.330, F.A.C...
(2) USE OF WELDED PIPING OR OTHERWISE RESTRAINED JOINTS FOR OTHER WATER MAIN OR THE OTHER PIPELINE...
(3) USE OF WATER-TIGHT CASING PIPE OR CONCRETE ENCASUREMENT AT LEAST FOUR INCHES THICK FOR OTHER WATER MAIN OR THE OTHER PIPELINE...
(4) WHERE AN UNDERGROUND WATER MAIN IS BEING LAID LESS THAN THE REQUIRED MINIMUM HORIZONTAL DISTANCE FROM ANOTHER UNDERGROUND WATER MAIN OR CONCRETE ENCASUREMENT, THE CONTRACTOR SHALL BE RESPONSIBLE FOR IDENTIFYING AND PROVIDING ALTERNATIVE CONSTRUCTION FEATURES...
(1) USE OF PIPE, OR CASING PIPE, HAVING HIGH IMPACT STRENGTH...
(2) USE OF PIPE, OR CASING PIPE, HAVING HIGH IMPACT STRENGTH...
(3) USE OF PIPE, OR CASING PIPE, HAVING HIGH IMPACT STRENGTH...
(4) USE OF PIPE, OR CASING PIPE, HAVING HIGH IMPACT STRENGTH...
(5) USE OF PIPE, OR CASING PIPE, HAVING HIGH IMPACT STRENGTH...

- 1. TECHNICAL OR ECONOMIC JUSTIFICATION FOR EACH CONFLICT MANHOLE...
2. A STATEMENT IDENTIFYING THE PARTY RESPONSIBLE FOR MAINTAINING EACH CONFLICT MANHOLE...
3. EVIDENCE OF COMPLIANCE WITH THE DESIGN AND CONSTRUCTION REQUIREMENTS IN SUB-PARAGRAPHS A THROUGH D, BELOW...
A. EACH WATER MAIN PASSING THROUGH A CONFLICT MANHOLE SHALL HAVE A FLEXIBLE MANHOLES JOINT ON EACH SIDE OF THE MANHOLE TO ACCOMMODATE DIFFERENTIAL SETTLEMENT BETWEEN THE MAIN AND THE MANHOLE...
B. WITHIN EACH CONFLICT MANHOLE, THE WATER MAIN PASSING THROUGH THE MANHOLE SHALL BE INSTALLED IN A WATER-TIGHT CASING PIPE HAVING HIGH IMPACT STRENGTH...
C. EACH CONFLICT MANHOLE SHALL HAVE AN ACCESS OPENING, AND SHALL BE SIZED TO ALLOW FOR EASY CLEANING OF THE WORK AREA...
D. GRATES SHALL BE INSTALLED AT ALL STORM SEWER MAINS UPSTREAM OF EACH CONFLICT MANHOLE TO PREVENT LARGE OBJECTS FROM ENTERING THE MANHOLE...
(E) SEPARATION BETWEEN FIRE HYDRANT MAINS AND SANITARY OR STORM SEWER, WASTEWATER OR STORMWATER FORCE MAINS, RECLAIMED WATER PIPELINES, AND ON-SITE SEWAGE TREATMENT AND DISPOSAL SYSTEMS, NEW OR RELOCATED FIRE HYDRANTS WITH UNDERGROUND DRINKS SHALL BE LOCATED SO THAT THE DRINKS ARE AT LEAST THREE FEET FROM ANY EXISTING OR PROPOSED STORM SEWER, STORMWATER FORCE MAIN, OR PIPELINE...
(F) SANITARY SEWER MAINS SHALL BE LOCATED AT LEAST SIX FEET FROM ANY EXISTING OR PROPOSED GRAVITY OR PRESSURE-TYPE SANITARY SEWER, WASTEWATER FORCE MAIN, OR PIPELINE...
(G) EXCEPTIONS, WHERE IT IS NOT TECHNICALLY FEASIBLE OR ECONOMICALLY DEPENDABLE TO COMPLY WITH THE REQUIREMENTS IN SUBSECTION (1) OR (2) ABOVE, THE CONTRACTOR SHALL ALLOW EXCEPTIONS TO THESE REQUIREMENTS...
(1) USE OF PRESSURE-TESTED PIPE CONFORMING TO THE AMERICAN WATER WORKS ASSOCIATION STANDARDS INCORPORATED INTO RULE 62-555.330, F.A.C...
(2) USE OF WELDED PIPING OR OTHERWISE RESTRAINED JOINTS FOR OTHER WATER MAIN OR THE OTHER PIPELINE...
(3) USE OF WATER-TIGHT CASING PIPE OR CONCRETE ENCASUREMENT AT LEAST FOUR INCHES THICK FOR OTHER WATER MAIN OR THE OTHER PIPELINE...
(4) WHERE AN UNDERGROUND WATER MAIN IS BEING LAID LESS THAN THE REQUIRED MINIMUM HORIZONTAL DISTANCE FROM ANOTHER UNDERGROUND WATER MAIN OR CONCRETE ENCASUREMENT, THE CONTRACTOR SHALL BE RESPONSIBLE FOR IDENTIFYING AND PROVIDING ALTERNATIVE CONSTRUCTION FEATURES...
(1) USE OF PIPE, OR CASING PIPE, HAVING HIGH IMPACT STRENGTH...
(2) USE OF PIPE, OR CASING PIPE, HAVING HIGH IMPACT STRENGTH...
(3) USE OF PIPE, OR CASING PIPE, HAVING HIGH IMPACT STRENGTH...
(4) USE OF PIPE, OR CASING PIPE, HAVING HIGH IMPACT STRENGTH...
(5) USE OF PIPE, OR CASING PIPE, HAVING HIGH IMPACT STRENGTH...

- 1. TECHNICAL OR ECONOMIC JUSTIFICATION FOR EACH CONFLICT MANHOLE...
2. A STATEMENT IDENTIFYING THE PARTY RESPONSIBLE FOR MAINTAINING EACH CONFLICT MANHOLE...
3. EVIDENCE OF COMPLIANCE WITH THE DESIGN AND CONSTRUCTION REQUIREMENTS IN SUB-PARAGRAPHS A THROUGH D, BELOW...
A. EACH WATER MAIN PASSING THROUGH A CONFLICT MANHOLE SHALL HAVE A FLEXIBLE MANHOLES JOINT ON EACH SIDE OF THE MANHOLE TO ACCOMMODATE DIFFERENTIAL SETTLEMENT BETWEEN THE MAIN AND THE MANHOLE...
B. WITHIN EACH CONFLICT MANHOLE, THE WATER MAIN PASSING THROUGH THE MANHOLE SHALL BE INSTALLED IN A WATER-TIGHT CASING PIPE HAVING HIGH IMPACT STRENGTH...
C. EACH CONFLICT MANHOLE SHALL HAVE AN ACCESS OPENING, AND SHALL BE SIZED TO ALLOW FOR EASY CLEANING OF THE WORK AREA...
D. GRATES SHALL BE INSTALLED AT ALL STORM SEWER MAINS UPSTREAM OF EACH CONFLICT MANHOLE TO PREVENT LARGE OBJECTS FROM ENTERING THE MANHOLE...
(E) SEPARATION BETWEEN FIRE HYDRANT MAINS AND SANITARY OR STORM SEWER, WASTEWATER OR STORMWATER FORCE MAINS, RECLAIMED WATER PIPELINES, AND ON-SITE SEWAGE TREATMENT AND DISPOSAL SYSTEMS, NEW OR RELOCATED FIRE HYDRANTS WITH UNDERGROUND DRINKS SHALL BE LOCATED SO THAT THE DRINKS ARE AT LEAST THREE FEET FROM ANY EXISTING OR PROPOSED STORM SEWER, STORMWATER FORCE MAIN, OR PIPELINE...
(F) SANITARY SEWER MAINS SHALL BE LOCATED AT LEAST SIX FEET FROM ANY EXISTING OR PROPOSED GRAVITY OR PRESSURE-TYPE SANITARY SEWER, WASTEWATER FORCE MAIN, OR PIPELINE...
(G) EXCEPTIONS, WHERE IT IS NOT TECHNICALLY FEASIBLE OR ECONOMICALLY DEPENDABLE TO COMPLY WITH THE REQUIREMENTS IN SUBSECTION (1) OR (2) ABOVE, THE CONTRACTOR SHALL ALLOW EXCEPTIONS TO THESE REQUIREMENTS...
(1) USE OF PRESSURE-TESTED PIPE CONFORMING TO THE AMERICAN WATER WORKS ASSOCIATION STANDARDS INCORPORATED INTO RULE 62-555.330, F.A.C...
(2) USE OF WELDED PIPING OR OTHERWISE RESTRAINED JOINTS FOR OTHER WATER MAIN OR THE OTHER PIPELINE...
(3) USE OF WATER-TIGHT CASING PIPE OR CONCRETE ENCASUREMENT AT LEAST FOUR INCHES THICK FOR OTHER WATER MAIN OR THE OTHER PIPELINE...
(4) WHERE AN UNDERGROUND WATER MAIN IS BEING LAID LESS THAN THE REQUIRED MINIMUM HORIZONTAL DISTANCE FROM ANOTHER UNDERGROUND WATER MAIN OR CONCRETE ENCASUREMENT, THE CONTRACTOR SHALL BE RESPONSIBLE FOR IDENTIFYING AND PROVIDING ALTERNATIVE CONSTRUCTION FEATURES...
(1) USE OF PIPE, OR CASING PIPE, HAVING HIGH IMPACT STRENGTH...
(2) USE OF PIPE, OR CASING PIPE, HAVING HIGH IMPACT STRENGTH...
(3) USE OF PIPE, OR CASING PIPE, HAVING HIGH IMPACT STRENGTH...
(4) USE OF PIPE, OR CASING PIPE, HAVING HIGH IMPACT STRENGTH...
(5) USE OF PIPE, OR CASING PIPE, HAVING HIGH IMPACT STRENGTH...

- 1. TECHNICAL OR ECONOMIC JUSTIFICATION FOR EACH CONFLICT MANHOLE...
2. A STATEMENT IDENTIFYING THE PARTY RESPONSIBLE FOR MAINTAINING EACH CONFLICT MANHOLE...
3. EVIDENCE OF COMPLIANCE WITH THE DESIGN AND CONSTRUCTION REQUIREMENTS IN SUB-PARAGRAPHS A THROUGH D, BELOW...
A. EACH WATER MAIN PASSING THROUGH A CONFLICT MANHOLE SHALL HAVE A FLEXIBLE MANHOLES JOINT ON EACH SIDE OF THE MANHOLE TO ACCOMMODATE DIFFERENTIAL SETTLEMENT BETWEEN THE MAIN AND THE MANHOLE...
B. WITHIN EACH CONFLICT MANHOLE, THE WATER MAIN PASSING THROUGH THE MANHOLE SHALL BE INSTALLED IN A WATER-TIGHT CASING PIPE HAVING HIGH IMPACT STRENGTH...
C. EACH CONFLICT MANHOLE SHALL HAVE AN ACCESS OPENING, AND SHALL BE SIZED TO ALLOW FOR EASY CLEANING OF THE WORK AREA...
D. GRATES SHALL BE INSTALLED AT ALL STORM SEWER MAINS UPSTREAM OF EACH CONFLICT MANHOLE TO PREVENT LARGE OBJECTS FROM ENTERING THE MANHOLE...
(E) SEPARATION BETWEEN FIRE HYDRANT MAINS AND SANITARY OR STORM SEWER, WASTEWATER OR STORMWATER FORCE MAINS, RECLAIMED WATER PIPELINES, AND ON-SITE SEWAGE TREATMENT AND DISPOSAL SYSTEMS, NEW OR RELOCATED FIRE HYDRANTS WITH UNDERGROUND DRINKS SHALL BE LOCATED SO THAT THE DRINKS ARE AT LEAST THREE FEET FROM ANY EXISTING OR PROPOSED STORM SEWER, STORMWATER FORCE MAIN, OR PIPELINE...
(F) SANITARY SEWER MAINS SHALL BE LOCATED AT LEAST SIX FEET FROM ANY EXISTING OR PROPOSED GRAVITY OR PRESSURE-TYPE SANITARY SEWER, WASTEWATER FORCE MAIN, OR PIPELINE...
(G) EXCEPTIONS, WHERE IT IS NOT TECHNICALLY FEASIBLE OR ECONOMICALLY DEPENDABLE TO COMPLY WITH THE REQUIREMENTS IN SUBSECTION (1) OR (2) ABOVE, THE CONTRACTOR SHALL ALLOW EXCEPTIONS TO THESE REQUIREMENTS...
(1) USE OF PRESSURE-TESTED PIPE CONFORMING TO THE AMERICAN WATER WORKS ASSOCIATION STANDARDS INCORPORATED INTO RULE 62-555.330, F.A.C...
(2) USE OF WELDED PIPING OR OTHERWISE RESTRAINED JOINTS FOR OTHER WATER MAIN OR THE OTHER PIPELINE...
(3) USE OF WATER-TIGHT CASING PIPE OR CONCRETE ENCASUREMENT AT LEAST FOUR INCHES THICK FOR OTHER WATER MAIN OR THE OTHER PIPELINE...
(4) WHERE AN UNDERGROUND WATER MAIN IS BEING LAID LESS THAN THE REQUIRED MINIMUM HORIZONTAL DISTANCE FROM ANOTHER UNDERGROUND WATER MAIN OR CONCRETE ENCASUREMENT, THE CONTRACTOR SHALL BE RESPONSIBLE FOR IDENTIFYING AND PROVIDING ALTERNATIVE CONSTRUCTION FEATURES...
(1) USE OF PIPE, OR CASING PIPE, HAVING HIGH IMPACT STRENGTH...
(2) USE OF PIPE, OR CASING PIPE, HAVING HIGH IMPACT STRENGTH...
(3) USE OF PIPE, OR CASING PIPE, HAVING HIGH IMPACT STRENGTH...
(4) USE OF PIPE, OR CASING PIPE, HAVING HIGH IMPACT STRENGTH...
(5) USE OF PIPE, OR CASING PIPE, HAVING HIGH IMPACT STRENGTH...

- 1. TECHNICAL OR ECONOMIC JUSTIFICATION FOR EACH CONFLICT MANHOLE...
2. A STATEMENT IDENTIFYING THE PARTY RESPONSIBLE FOR MAINTAINING EACH CONFLICT MANHOLE...
3. EVIDENCE OF COMPLIANCE WITH THE DESIGN AND CONSTRUCTION REQUIREMENTS IN SUB-PARAGRAPHS A THROUGH D, BELOW...
A. EACH WATER MAIN PASSING THROUGH A CONFLICT MANHOLE SHALL HAVE A FLEXIBLE MANHOLES JOINT ON EACH SIDE OF THE MANHOLE TO ACCOMMODATE DIFFERENTIAL SETTLEMENT BETWEEN THE MAIN AND THE MANHOLE...
B. WITHIN EACH CONFLICT MANHOLE, THE WATER MAIN PASSING THROUGH THE MANHOLE SHALL BE INSTALLED IN A WATER-TIGHT CASING PIPE HAVING HIGH IMPACT STRENGTH...
C. EACH CONFLICT MANHOLE SHALL HAVE AN ACCESS OPENING, AND SHALL BE SIZED TO ALLOW FOR EASY CLEANING OF THE WORK AREA...
D. GRATES SHALL BE INSTALLED AT ALL STORM SEWER MAINS UPSTREAM OF EACH CONFLICT MANHOLE TO PREVENT LARGE OBJECTS FROM ENTERING THE MANHOLE...
(E) SEPARATION BETWEEN FIRE HYDRANT MAINS AND SANITARY OR STORM SEWER, WASTEWATER OR STORMWATER FORCE MAINS, RECLAIMED WATER PIPELINES, AND ON-SITE SEWAGE TREATMENT AND DISPOSAL SYSTEMS, NEW OR RELOCATED FIRE HYDRANTS WITH UNDERGROUND DRINKS SHALL BE LOCATED SO THAT THE DRINKS ARE AT LEAST THREE FEET FROM ANY EXISTING OR PROPOSED STORM SEWER, STORMWATER FORCE MAIN, OR PIPELINE...
(F) SANITARY SEWER MAINS SHALL BE LOCATED AT LEAST SIX FEET FROM ANY EXISTING OR PROPOSED GRAVITY OR PRESSURE-TYPE SANITARY SEWER, WASTEWATER FORCE MAIN, OR PIPELINE...
(G) EXCEPTIONS, WHERE IT IS NOT TECHNICALLY FEASIBLE OR ECONOMICALLY DEPENDABLE TO COMPLY WITH THE REQUIREMENTS IN SUBSECTION (1) OR (2) ABOVE, THE CONTRACTOR SHALL ALLOW EXCEPTIONS TO THESE REQUIREMENTS...
(1) USE OF PRESSURE-TESTED PIPE CONFORMING TO THE AMERICAN WATER WORKS ASSOCIATION STANDARDS INCORPORATED INTO RULE 62-555.330, F.A.C...
(2) USE OF WELDED PIPING OR OTHERWISE RESTRAINED JOINTS FOR OTHER WATER MAIN OR THE OTHER PIPELINE...
(3) USE OF WATER-TIGHT CASING PIPE OR CONCRETE ENCASUREMENT AT LEAST FOUR INCHES THICK FOR OTHER WATER MAIN OR THE OTHER PIPELINE...
(4) WHERE AN UNDERGROUND WATER MAIN IS BEING LAID LESS THAN THE REQUIRED MINIMUM HORIZONTAL DISTANCE FROM ANOTHER UNDERGROUND WATER MAIN OR CONCRETE ENCASUREMENT, THE CONTRACTOR SHALL BE RESPONSIBLE FOR IDENTIFYING AND PROVIDING ALTERNATIVE CONSTRUCTION FEATURES...
(1) USE OF PIPE, OR CASING PIPE, HAVING HIGH IMPACT STRENGTH...
(2) USE OF PIPE, OR CASING PIPE, HAVING HIGH IMPACT STRENGTH...
(3) USE OF PIPE, OR CASING PIPE, HAVING HIGH IMPACT STRENGTH...
(4) USE OF PIPE, OR CASING PIPE, HAVING HIGH IMPACT STRENGTH...
(5) USE OF PIPE, OR CASING PIPE, HAVING HIGH IMPACT STRENGTH...

- 1. TECHNICAL OR ECONOMIC JUSTIFICATION FOR EACH CONFLICT MANHOLE...
2. A STATEMENT IDENTIFYING THE PARTY RESPONSIBLE FOR MAINTAINING EACH CONFLICT MANHOLE...
3. EVIDENCE OF COMPLIANCE WITH THE DESIGN AND CONSTRUCTION REQUIREMENTS IN SUB-PARAGRAPHS A THROUGH D, BELOW...
A. EACH WATER MAIN PASSING THROUGH A CONFLICT MANHOLE SHALL HAVE A FLEXIBLE MANHOLES JOINT ON EACH SIDE OF THE MANHOLE TO ACCOMMODATE DIFFERENTIAL SETTLEMENT BETWEEN THE MAIN AND THE MANHOLE...
B. WITHIN EACH CONFLICT MANHOLE, THE WATER MAIN PASSING THROUGH THE MANHOLE SHALL BE INSTALLED IN A WATER-TIGHT CASING PIPE HAVING HIGH IMPACT STRENGTH...
C. EACH CONFLICT MANHOLE SHALL HAVE AN ACCESS OPENING, AND SHALL BE SIZED TO ALLOW FOR EASY CLEANING OF THE WORK AREA...
D. GRATES SHALL BE INSTALLED AT ALL STORM SEWER MAINS UPSTREAM OF EACH CONFLICT MANHOLE TO PREVENT LARGE OBJECTS FROM ENTERING THE MANHOLE...
(E) SEPARATION BETWEEN FIRE HYDRANT MAINS AND SANITARY OR STORM SEWER, WASTEWATER OR STORMWATER FORCE MAINS, RECLAIMED WATER PIPELINES, AND ON-SITE SEWAGE TREATMENT AND DISPOSAL SYSTEMS, NEW OR RELOCATED FIRE HYDRANTS WITH UNDERGROUND DRINKS SHALL BE LOCATED SO THAT THE DRINKS ARE AT LEAST THREE FEET FROM ANY EXISTING OR PROPOSED STORM SEWER, STORMWATER FORCE MAIN, OR PIPELINE...
(F) SANITARY SEWER MAINS SHALL BE LOCATED AT LEAST SIX FEET FROM ANY EXISTING OR PROPOSED GRAVITY OR PRESSURE-TYPE SANITARY SEWER, WASTEWATER FORCE MAIN, OR PIPELINE...
(G) EXCEPTIONS, WHERE IT IS NOT TECHNICALLY FEASIBLE OR ECONOMICALLY DEPENDABLE TO COMPLY WITH THE REQUIREMENTS IN SUBSECTION (1) OR (2) ABOVE, THE CONTRACTOR SHALL ALLOW EXCEPTIONS TO THESE REQUIREMENTS...
(1) USE OF PRESSURE-TESTED PIPE CONFORMING TO THE AMERICAN WATER WORKS ASSOCIATION STANDARDS INCORPORATED INTO RULE 62-555.330, F.A.C...
(2) USE OF WELDED PIPING OR OTHERWISE RESTRAINED JOINTS FOR OTHER WATER MAIN OR THE OTHER PIPELINE...
(3) USE OF WATER-TIGHT CASING PIPE OR CONCRETE ENCASUREMENT AT LEAST FOUR INCHES THICK FOR OTHER WATER MAIN OR THE OTHER PIPELINE...
(4) WHERE AN UNDERGROUND WATER MAIN IS BEING LAID LESS THAN THE REQUIRED MINIMUM HORIZONTAL DISTANCE FROM ANOTHER UNDERGROUND WATER MAIN OR CONCRETE ENCASUREMENT, THE CONTRACTOR SHALL BE RESPONSIBLE FOR IDENTIFYING AND PROVIDING ALTERNATIVE CONSTRUCTION FEATURES...
(1) USE OF PIPE, OR CASING PIPE, HAVING HIGH IMPACT STRENGTH...
(2) USE OF PIPE, OR CASING PIPE, HAVING HIGH IMPACT STRENGTH...
(3) USE OF PIPE, OR CASING PIPE, HAVING HIGH IMPACT STRENGTH...
(4) USE OF PIPE, OR CASING PIPE, HAVING HIGH IMPACT STRENGTH...
(5) USE OF PIPE, OR CASING PIPE, HAVING HIGH IMPACT STRENGTH...
HYDROSTATIC TESTING NOTES:
1. AFTER ALL PRESSURE PIPES ARE INSTALLED, THE JOINTS COMPLETED, AND THE TRENCH BACKFILLED, THE MOUNTED LAID PIPE AND APPURTENANCES SHALL BE SUBJECTED TO A HYDROSTATIC TEST FOR A PERIOD OF AT LEAST TWO (2) HOURS...
AND THE SJCUD MUST BE NOTIFIED AT LEAST 72 HOURS BEFORE A TEST IS TO BE PERFORMED...
TEST SHALL BE AS SET FORTH IN AWWA STANDARD C901...
RESULTS DETECTED SHALL BE CORRECTED AND THE SECTION OF PIPELINE RETESTED...
IF AFTER SEVERAL TESTS THE RESULTS SHOW LEAKAGE, THE JOINTS WILL BE DETERMINED TO BE WATER TIGHT...
LEAKAGE SHALL BE LIMITED TO THAT ALLOWANCE SET FORTH IN SECTION 62-555.330...
LEAKAGE SHALL BE LIMITED TO THAT ALLOWANCE SET FORTH IN SECTION 62-555.330...
LEAKAGE SHALL BE LIMITED TO THAT ALLOWANCE SET FORTH IN SECTION 62-555.330...
LEAKAGE SHALL BE LIMITED TO THAT ALLOWANCE SET FORTH IN SECTION 62-555.330...
LEAKAGE SHALL BE LIMITED TO THAT ALLOWANCE SET FORTH IN SECTION 62-555.330...





ST. JOHNS COUNTY UTILITY DEPARTMENT  
 1205 STATE ROAD 16  
 ST AUGUSTINE, FLORIDA 32084  
 Phone (904) 209-2700

AMENDMENTS	Date: 8/29/17	Drawn By: JLD
		Checked By: JLD
		Special By:

NORTHWEST WTP 20-IN WATER MAIN EXTENSION	DATE: 8/29/17
	SCALE: 1" = 20'
UTILITY SITE PLAN	

DATE: 8/29/17
FILE NUMBER:
SHEET NO. 3
OF 5

SEE SHEET 3 OF 5

O.A. 1003 PG.

FUTURE CR 2209 RIGHT OF WAY

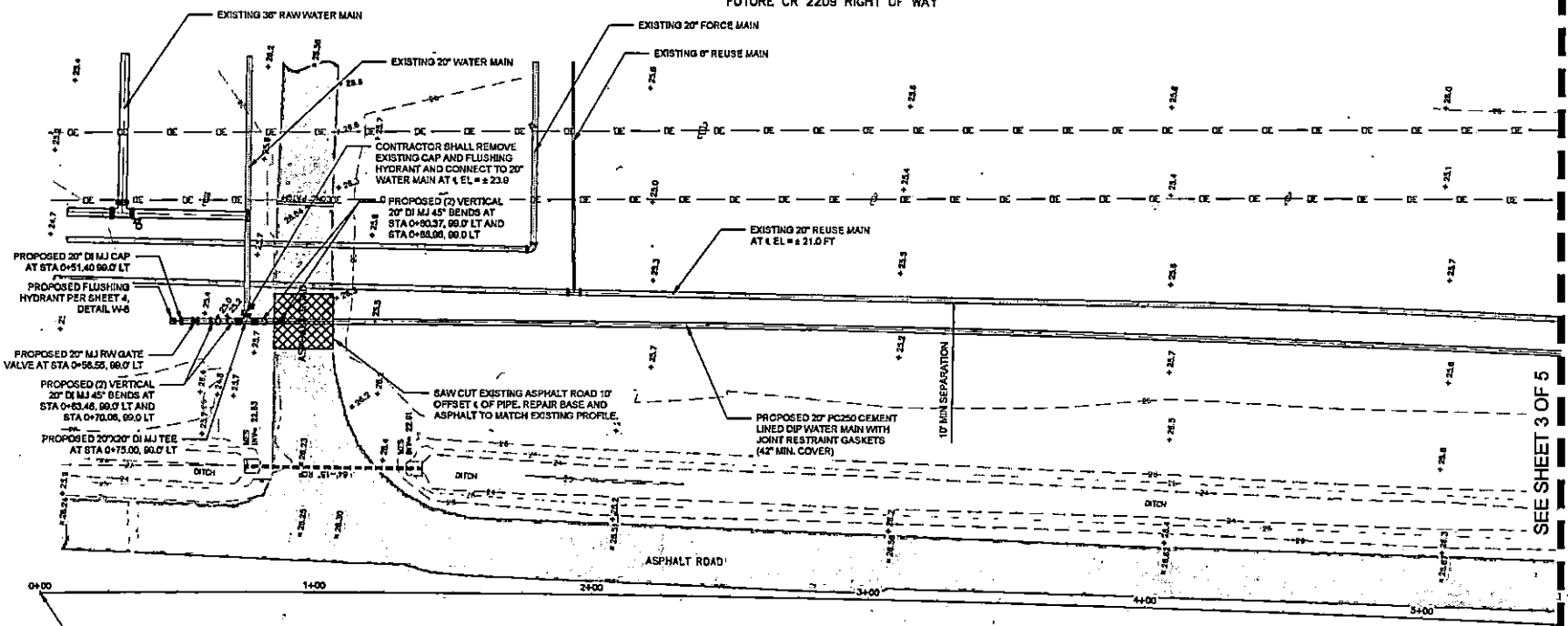

**UTILITY PLAN**  
 SCALE 1" = 20'

FUTURE CR 2209 RIGHT OF WAY

BEGIN STATION LINE  
 N: 2049622.53  
 E: 502024.81

C.E. 1995 PL

FUTURE CR 2209 RIGHT OF WAY

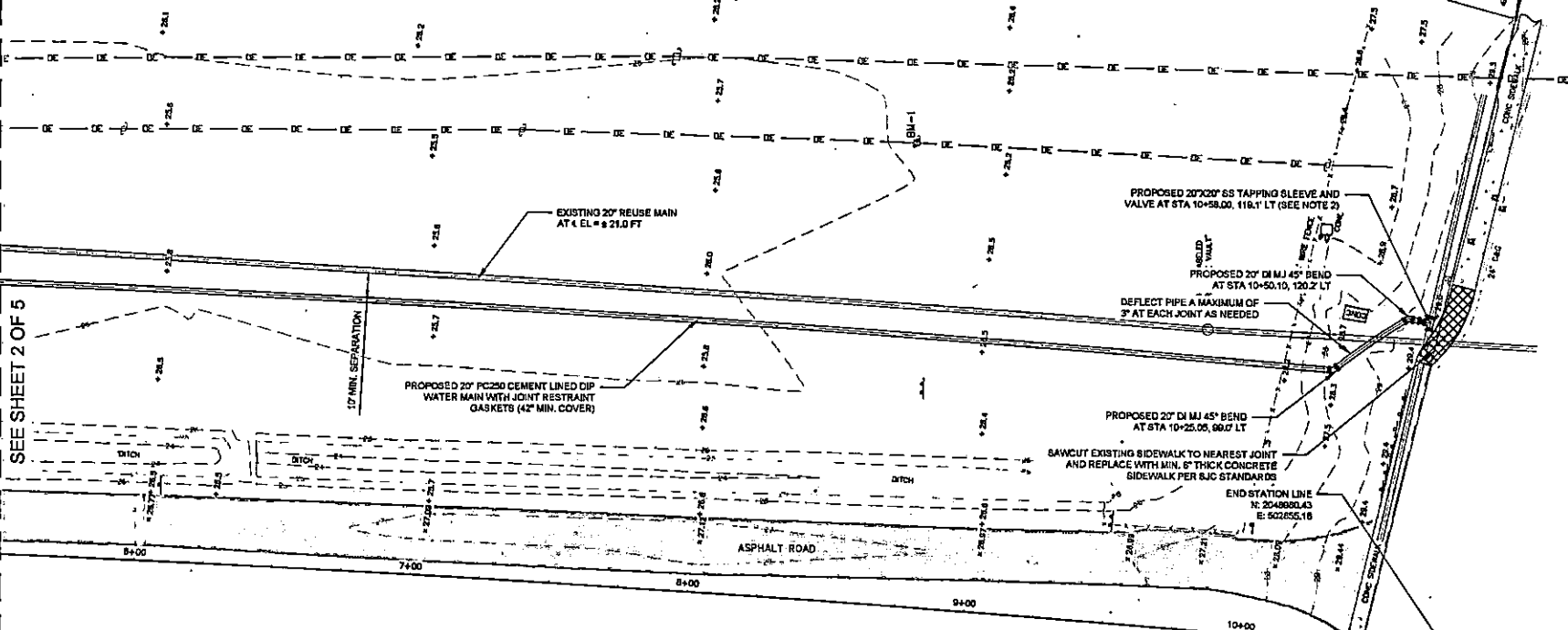

SEE SHEET 2 OF 5

GENERAL NOTES:

1. THE CONTRACTOR SHALL PERFORM PRESSURE LEAKAGE TESTING, FLUSHING AND DISINFECTION OF THE NEW WATER TRANSMISSION MAIN IN ACCORDANCE WITH SJCUD AND AWWA STANDARDS.
2. THE WATER MAIN TAP ON INTERNATIONAL GOLF PARKWAY SHALL BE PERFORMED AFTER FDEP CLEARANCE OF THE NEW 20" WATER TRANSMISSION MAIN. THE CONTRACTOR SHALL NOTIFY SJCUD ONE WEEK IN ADVANCE.
3. THE CONTRACTOR SHALL HAVE TRAFFIC CONTROL PER FDOT INDEX 012 IF WORK AREA IS WITHIN 15 FT OF THE TRAVEL LANE OR FDOT INDEX 013 IF THE WORK AREA IS WITHIN 3 FT OF THE TRAVEL LANE.
4. ALL DISTURBED AREAS SHALL BE RESTORED WITH SEED AND MULCH.

UTILITY PLAN  
SCALE 1" = 20'

FUTURE CR 2209 RIGHT OF WAY

INTERNATIONAL GOLF PKWY  
RIGHT OF WAY VARIES  
ASPHALT



ST. JOHNS COUNTY UTILITY DEPARTMENT  
12045 STATE ROAD 16  
ST AUGUSTINE, FLORIDA 32084  
Phone (904) 209-2700

AMENDMENTS	Checked By: JND	Checked By: JND	Checked By: JND
	Date: 9/29/17	Date: 9/29/17	Date: 9/29/17
	Checked By: JND	Checked By: JND	Checked By: JND
	Date: 9/29/17	Date: 9/29/17	Date: 9/29/17

NORTHWEST WTP 20-IN WATER MAIN EXTENSION
UTILITY SITE PLAN

DATE: 9/29/17  
FILE NUMBER:  
SHEET NO. 3  
OF 5

ST. JOHN'S COUNTY UTILITY DEPARTMENT  
RESTRAINT JOINT TABLE

THIS TABLE IS TO BE USED TO DETERMINE THE RESTRAINT JOINT JOINT TO BE USED FOR RESTRAINT JOINTS. THE JOINT TO BE USED IS DETERMINED BY THE SIZE OF THE PIPE AND THE TYPE OF RESTRAINT JOINT. THE JOINT TO BE USED IS DETERMINED BY THE SIZE OF THE PIPE AND THE TYPE OF RESTRAINT JOINT.

RESTRAINT JOINT	PIPE SIZE (IN)	RESTRAINT JOINT	PIPE SIZE (IN)
1	12	1	12
2	18	2	18
3	24	3	24
4	30	4	30
5	36	5	36
6	42	6	42
7	48	7	48
8	54	8	54
9	60	9	60
10	66	10	66
11	72	11	72
12	78	12	78
13	84	13	84
14	90	14	90
15	96	15	96
16	102	16	102
17	108	17	108
18	114	18	114
19	120	19	120
20	126	20	126
21	132	21	132
22	138	22	138
23	144	23	144
24	150	24	150
25	156	25	156
26	162	26	162
27	168	27	168
28	174	28	174
29	180	29	180
30	186	30	186
31	192	31	192
32	198	32	198
33	204	33	204
34	210	34	210
35	216	35	216
36	222	36	222
37	228	37	228
38	234	38	234
39	240	39	240
40	246	40	246
41	252	41	252
42	258	42	258
43	264	43	264
44	270	44	270
45	276	45	276
46	282	46	282
47	288	47	288
48	294	48	294
49	300	49	300
50	306	50	306
51	312	51	312
52	318	52	318
53	324	53	324
54	330	54	330
55	336	55	336
56	342	56	342
57	348	57	348
58	354	58	354
59	360	59	360
60	366	60	366
61	372	61	372
62	378	62	378
63	384	63	384
64	390	64	390
65	396	65	396
66	402	66	402
67	408	67	408
68	414	68	414
69	420	69	420
70	426	70	426
71	432	71	432
72	438	72	438
73	444	73	444
74	450	74	450
75	456	75	456
76	462	76	462
77	468	77	468
78	474	78	474
79	480	79	480
80	486	80	486
81	492	81	492
82	498	82	498
83	504	83	504
84	510	84	510
85	516	85	516
86	522	86	522
87	528	87	528
88	534	88	534
89	540	89	540
90	546	90	546
91	552	91	552
92	558	92	558
93	564	93	564
94	570	94	570
95	576	95	576
96	582	96	582
97	588	97	588
98	594	98	594
99	600	99	600
100	606	100	606

MANUAL TO BE USED TO DETERMINE RESTRAINT JOINT TO BE USED FOR RESTRAINT JOINTS.

RESTRAINT JOINT	PIPE SIZE (IN)	RESTRAINT JOINT	PIPE SIZE (IN)
1	12	1	12
2	18	2	18
3	24	3	24
4	30	4	30
5	36	5	36
6	42	6	42
7	48	7	48
8	54	8	54
9	60	9	60
10	66	10	66
11	72	11	72
12	78	12	78
13	84	13	84
14	90	14	90
15	96	15	96
16	102	16	102
17	108	17	108
18	114	18	114
19	120	19	120
20	126	20	126
21	132	21	132
22	138	22	138
23	144	23	144
24	150	24	150
25	156	25	156
26	162	26	162
27	168	27	168
28	174	28	174
29	180	29	180
30	186	30	186
31	192	31	192
32	198	32	198
33	204	33	204
34	210	34	210
35	216	35	216
36	222	36	222
37	228	37	228
38	234	38	234
39	240	39	240
40	246	40	246
41	252	41	252
42	258	42	258
43	264	43	264
44	270	44	270
45	276	45	276
46	282	46	282
47	288	47	288
48	294	48	294
49	300	49	300
50	306	50	306
51	312	51	312
52	318	52	318
53	324	53	324
54	330	54	330
55	336	55	336
56	342	56	342
57	348	57	348
58	354	58	354
59	360	59	360
60	366	60	366
61	372	61	372
62	378	62	378
63	384	63	384
64	390	64	390
65	396	65	396
66	402	66	402
67	408	67	408
68	414	68	414
69	420	69	420
70	426	70	426
71	432	71	432
72	438	72	438
73	444	73	444
74	450	74	450
75	456	75	456
76	462	76	462
77	468	77	468
78	474	78	474
79	480	79	480
80	486	80	486
81	492	81	492
82	498	82	498
83	504	83	504
84	510	84	510
85	516	85	516
86	522	86	522
87	528	87	528
88	534	88	534
89	540	89	540
90	546	90	546
91	552	91	552
92	558	92	558
93	564	93	564
94	570	94	570
95	576	95	576
96	582	96	582
97	588	97	588
98	594	98	594
99	600	99	600
100	606	100	606

ST. JOHN'S COUNTY UTILITY DEPARTMENT  
THE B  
BELOW & HOUSING

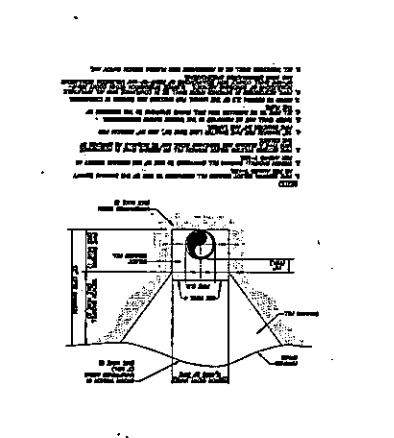

ST. JOHN'S COUNTY UTILITY DEPARTMENT  
GATE VALVE & BOX  
FOR PAVED  
LOCATIONS

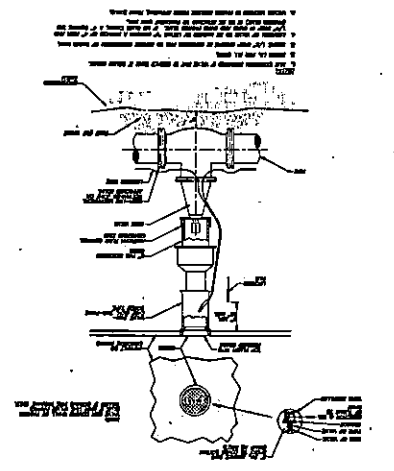

ST. JOHN'S COUNTY UTILITY DEPARTMENT  
N° RESTRAINT  
GATE VALVE  
ALONG PIPE

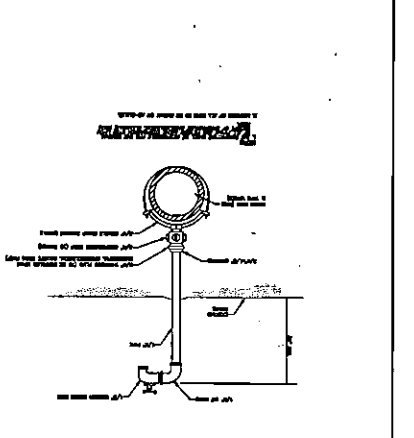

ST. JOHN'S COUNTY UTILITY DEPARTMENT  
MECHANICAL RESTRAINTS  
PIUGED DEAD END

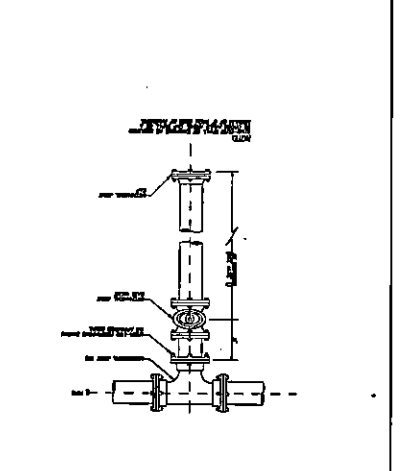

ST. JOHN'S COUNTY UTILITY DEPARTMENT  
LOCATE DEVICE  
STATION DEVICE

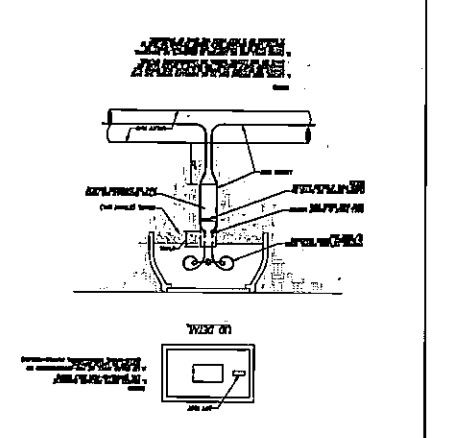

ST. JOHN'S COUNTY UTILITY DEPARTMENT  
2" FLUSHING HYDRANT  
BELOW GRADE TYPE

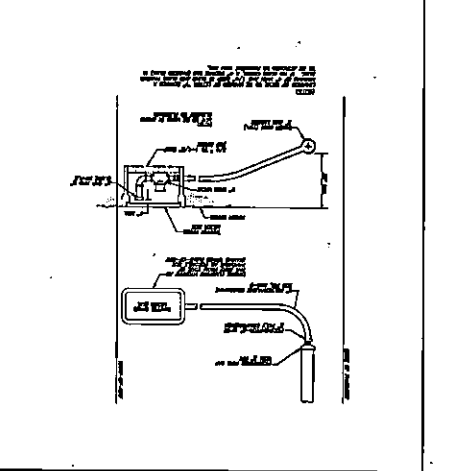

NORTHWEST 20'-IN WATER MAIN EXTENSION  
 SAGD STANDARD DETAILS  
 ADJUSTMENTS  
 DATE: 9/26/21  
 DRAWN BY: JLD  
 CHECKED BY: JLD  
 ST. JOHN'S COUNTY UTILITY DEPARTMENT  
 1208 STATE ROAD 16  
 ST AUGUSTINE, FLORIDA 32084  
 PHONE (904) 208-2700





ST. JOHNS COUNTY UTILITY DEPARTMENT  
 1205 STATE ROAD 16  
 ST AUGUSTINE, FLORIDA 32084  
 Phone (904) 209-2700

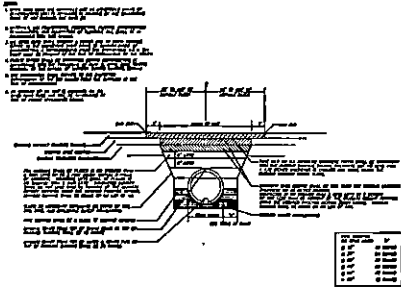

101 OPEN ROAD OUTFILL/COMPACTED FILL

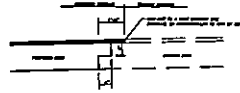

117 SAW-CUT DETAIL

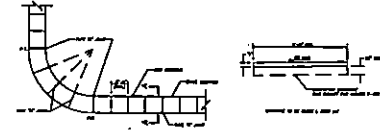

TABLE OF SYMBOLS

Symbol	Description
W	Work Area
C	Channeling Device (See Index No. 802)
D	Work Zone Sign
L	Light Installation or Direction of Traffic

SCALE OF SYMBOLS

Symbol	Description
W	Work Area
C	Channeling Device (See Index No. 802)
D	Work Zone Sign
L	Light Installation or Direction of Traffic

118 SIDEWALK DETAILS

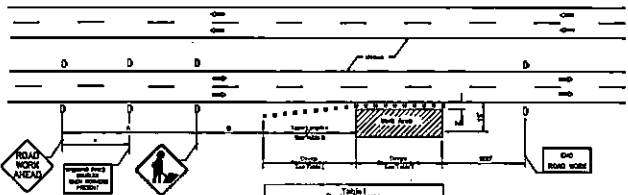

DISTANCE BETWEEN SIGNS

Sign	Spacing (ft)
1st sign to work area	300
2nd sign to work area	150
3rd sign to work area	75
4th sign to work area	30

Table 1  
 Deviation Spacing

Dist. Between Deviation (ft)	Spacing (ft)
0-100	100
100-200	200
200-300	300
300-400	400
400-500	500
500-600	600
600-700	700
700-800	800
800-900	900
900-1000	1000

GENERAL NOTES

1. Work area shall be defined by signs, barriers, and flagmen as shown on this plan.
2. All work shall be done in accordance with the Florida Department of Transportation Standard Specifications for Road and Bridge Construction, 1994 Edition, Section 100.
3. All work shall be done in accordance with the Florida Department of Transportation Standard Specifications for Road and Bridge Construction, 1994 Edition, Section 100.
4. All work shall be done in accordance with the Florida Department of Transportation Standard Specifications for Road and Bridge Construction, 1994 Edition, Section 100.
5. All work shall be done in accordance with the Florida Department of Transportation Standard Specifications for Road and Bridge Construction, 1994 Edition, Section 100.

DURATION NOTES

1. All work shall be done in accordance with the Florida Department of Transportation Standard Specifications for Road and Bridge Construction, 1994 Edition, Section 100.
2. All work shall be done in accordance with the Florida Department of Transportation Standard Specifications for Road and Bridge Construction, 1994 Edition, Section 100.
3. All work shall be done in accordance with the Florida Department of Transportation Standard Specifications for Road and Bridge Construction, 1994 Edition, Section 100.

SYMBOLS

- W Work Area
- C Channeling Device (See Index No. 802)
- D Work Zone Sign
- L Light Installation or Direction of Traffic

Table 2  
 Taper Length

Sign	Spacing (ft)	Width (ft)
1st sign to work area	300	10
2nd sign to work area	150	5
3rd sign to work area	75	2.5
4th sign to work area	30	1.25

CONDITIONS

1. All work shall be done in accordance with the Florida Department of Transportation Standard Specifications for Road and Bridge Construction, 1994 Edition, Section 100.

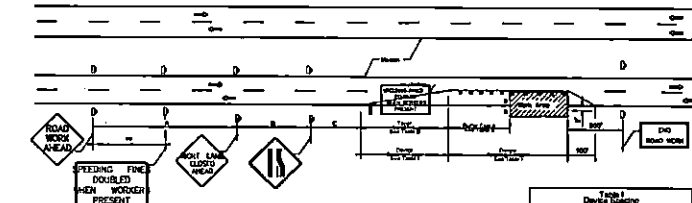

DISTANCE BETWEEN SIGNS

Sign	Spacing (ft)
1st sign to work area	300
2nd sign to work area	150
3rd sign to work area	75
4th sign to work area	30

GENERAL NOTES

1. Work area shall be defined by signs, barriers, and flagmen as shown on this plan.
2. All work shall be done in accordance with the Florida Department of Transportation Standard Specifications for Road and Bridge Construction, 1994 Edition, Section 100.
3. All work shall be done in accordance with the Florida Department of Transportation Standard Specifications for Road and Bridge Construction, 1994 Edition, Section 100.
4. All work shall be done in accordance with the Florida Department of Transportation Standard Specifications for Road and Bridge Construction, 1994 Edition, Section 100.
5. All work shall be done in accordance with the Florida Department of Transportation Standard Specifications for Road and Bridge Construction, 1994 Edition, Section 100.

DURATION NOTES

1. All work shall be done in accordance with the Florida Department of Transportation Standard Specifications for Road and Bridge Construction, 1994 Edition, Section 100.
2. All work shall be done in accordance with the Florida Department of Transportation Standard Specifications for Road and Bridge Construction, 1994 Edition, Section 100.
3. All work shall be done in accordance with the Florida Department of Transportation Standard Specifications for Road and Bridge Construction, 1994 Edition, Section 100.

SYMBOLS

- W Work Area
- C Channeling Device (See Index No. 802)
- D Work Zone Sign
- L Light Installation or Direction of Traffic

Table 3  
 Deviation Spacing

Dist. Between Deviation (ft)	Spacing (ft)
0-100	100
100-200	200
200-300	300
300-400	400
400-500	500
500-600	600
600-700	700
700-800	800
800-900	900
900-1000	1000

Table 4  
 Taper Length

Sign	Spacing (ft)	Width (ft)
1st sign to work area	300	10
2nd sign to work area	150	5
3rd sign to work area	75	2.5
4th sign to work area	30	1.25

GENERAL NOTES

1. Work area shall be defined by signs, barriers, and flagmen as shown on this plan.
2. All work shall be done in accordance with the Florida Department of Transportation Standard Specifications for Road and Bridge Construction, 1994 Edition, Section 100.
3. All work shall be done in accordance with the Florida Department of Transportation Standard Specifications for Road and Bridge Construction, 1994 Edition, Section 100.
4. All work shall be done in accordance with the Florida Department of Transportation Standard Specifications for Road and Bridge Construction, 1994 Edition, Section 100.
5. All work shall be done in accordance with the Florida Department of Transportation Standard Specifications for Road and Bridge Construction, 1994 Edition, Section 100.

DURATION NOTES

1. All work shall be done in accordance with the Florida Department of Transportation Standard Specifications for Road and Bridge Construction, 1994 Edition, Section 100.
2. All work shall be done in accordance with the Florida Department of Transportation Standard Specifications for Road and Bridge Construction, 1994 Edition, Section 100.
3. All work shall be done in accordance with the Florida Department of Transportation Standard Specifications for Road and Bridge Construction, 1994 Edition, Section 100.

SYMBOLS

- W Work Area
- C Channeling Device (See Index No. 802)
- D Work Zone Sign
- L Light Installation or Direction of Traffic

AMENDMENTS

Date: 9/29/17	By: JLD
Date: 9/29/17	By: JLD
Date: 9/29/17	By: JLD
Date: 9/29/17	By: JLD

Drawn by: JLD  
 Checked by: JLD  
 Special Use: \_\_\_\_\_

NORTHWEST WTP 20-IN WATER MAIN EXTENSION

MISCELLANEOUS DETAILS

DATE: 9/1/17  
 FILE NUMBER: \_\_\_\_\_  
 SHEET NO. 6 OF 6

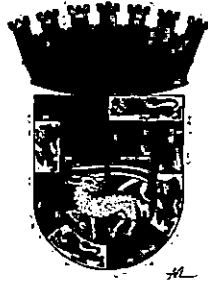

**Board of County Commissioners  
St. Johns County Florida**

**BID NO: 18-32**

**NORTHWEST WTP 20 INCH WATER MAIN EXTENSION**

**BID DOCUMENTS  
PROJECT SPECIFICATIONS**

**St. Johns County Purchasing Department  
500 San Sebastian View  
St. Augustine FL 32084  
904.209.0150**

**FINAL: 12/01/17**

**Bid No: 18-32; Northwest WTP 20 Inch Water Main Extension**

**TABLE OF CONTENTS**

**FRONT END BID DOCUMENTS**

Notice to Bidders

Instruction to Bidders

Official County Unit Price Bid Form

Attachments:

“A” – St Johns County Board of County Commissioners Affidavit

“B” – Certificate as to Corporate Principal

“C” – License/Certification List

“D” – List of Proposed Sub-Contractors/Suppliers

“E” – Conflict of Interest Disclosure Form

“F” – Certificate of Compliance with Florida Trench Safety Act

“G” – Proof of Insurance

“H” – Experience of Bidder Form

Bid Bond

**PROJECT SPECIFICATIONS/DRAWINGS**

**SEALED BID MAILING LABEL**

**END OF TABLE OF CONTENTS**

**BID NO: 18-32**

**NOTICE TO BIDDERS**

Notice is hereby given that sealed bids will be received until 2:00 P.M. on Wednesday, January 10, 2018 by the St. Johns County Purchasing Department, located at 500 San Sebastian View, St. Augustine, Florida 32084 for **Bid No: 18-32; Northwest WTP 20 Inch Water Main Extension**. Bids will be opened promptly after the 2:00 P.M. deadline. **Note:** Bids delivered or received in the Purchasing Department after the 2:00 P.M. deadline shall not be give consideration and shall be returned to the sender unopened.

**Scope of Work**

The Contractor shall furnish all labor, equipment and material necessary for the construction of a 1020 LF 20" DI PC250 water main extension from the entrance road of the Northwest WTP to International Golf Pkwy. within the future right-of-way (ROW) of CR2209 per the plans provided. The project shall be constructed according to the St. Johns County Utility Department (SJCUD) Manual of Water, Wastewater, and Reuse Design Standards and Specifications, Latest Edition, which can be located at:

<http://www.sjcfl.us/Utilities/media/DevGroup/WaterStds&SpecsManual.pdf>.

The Contractor is strongly recommended to visit the project site to familiarize themselves with the existing conditions under which the Work is to be performed. The Site can be accessed during normal business hours (Monday-Friday from 7:00am to 4:30pm). Please see the Location Map provided.

**Minimum Qualifications**

Prime bidder must be fully licensed to do business in the State of Florida and be currently licensed as a Certified Underground Utility Contractor or Certified General Contractor in the State of Florida, and provide proof of licensure with the submitted Bid Proposal. Bidders must have successfully completed, as a Prime or Sub-contractor, at least three (3) projects, in the past five (5) years, of similar type, size and dollar value of the project described herein.

**Bid Documents, Project Specifications and Drawings**

Documents related to this bid may be obtained from Onvia DemandStar, Inc., at the following web address: [www.demandstar.com](http://www.demandstar.com) by requesting St. Johns County Bid Document #18-32. For technical assistance with this Website please contact Onvia Supplier Services at 1-800-711-1712. A link to the Onvia DemandStar website is available through the St. Johns County Purchasing Website by clicking on the following link: [www.sjcfl.us/BCC/Purchasing/Open\\_Bids.aspx](http://www.sjcfl.us/BCC/Purchasing/Open_Bids.aspx). Check the County's site for download availability and any applicable fees. Bid Documents may also be requested, *in writing*, from the St. Johns County Purchasing Department Point of Contact, Leigh Daniels, CPPB, via email: [ldaniels@sjcfl.us](mailto:ldaniels@sjcfl.us) or fax:(904) 209-0155.

**Point of Contact**

Any and all questions related to this project shall be directed, *in writing*, to Leigh Daniels, CPPB, Procurement Supervisor, SJC Purchasing Department, via email to [ldaniels@sjcfl.us](mailto:ldaniels@sjcfl.us) or fax to (904) 209-0155. Questions must be submitted, in writing, no later than four o'clock (4:00PM) on Wednesday, December 27, 2017, so that any necessary addenda may be issued in a timely manner. Any questions received after the deadline will not be answered unless previously approved by the SJC Purchasing Manager or other designated County Representative.

Any bidder, proposer or person substantially and adversely affected by an intended decision or by an term, condition, procedure or specification with respect to any bid, invitation, solicitation of proposals or requests for qualifications, shall file with the Purchasing Department for St. Johns County, a written notice of intent to protest no later than 72 hours (excluding Saturdays, Sundays and legal holidays for employees of St. Johns County) after the posting either electronically or by other means of the notice of intended action, notice of

intended award, bid tabulation, publication by posting electronically or by other means of a procedure, specification, term or condition which the person intends to protest, or the right to protest such matter shall be waived. The protest procedures may be obtained from the Purchasing Department and are included in the County's Purchasing Manual. All of the terms and conditions of the County Purchasing Manual are incorporated by reference and are fully binding.

**Vendors shall not contact, lobby, or otherwise communicate with any SJC employee, including any member of the Board of County Commissioners, other than the above referenced individual from the point of advertisement of the Bid until contract(s) are executed by all parties, per SJC Purchasing Code 304.6.5 "Procedures Concerning Lobbying". According to SJC policy, any such communication shall disqualify the vendor, contractor, or consultant from responding to the subject invitation to bid, request for quote, request for proposal, invitation to negotiate, or request for qualifications. St. Johns County reserves the right to accept or reject any or all bids/proposals, waive minor formalities, and to award the bid/proposal that best serves the interests of St. Johns County. St. Johns County also reserves the right to award the base bid and any alternate bids in any combination that best suits the needs of the County.**

St. Johns County reserves the right to accept or reject any or all bids/proposals, waive minor formalities, and to award the bid/proposal that best serves the interests of St. Johns County. St. Johns County also reserves the right to award the base bid and any alternate bids in any combination that best suits the needs of the County.

BOARD OF COUNTY COMMISSIONERS  
OF ST. JOHNS COUNTY, FLORIDA  
HUNTER S. CONRAD, CLERK  
BY: \_\_\_\_\_

Deputy Clerk



# **FRONT END BID DOCUMENTS**

## **INSTRUCTION TO BIDDERS**

**OWNER:** The Board of County Commissioners of St. Johns County, Florida ("County") OR ("Owner")

**PROJECT:** BID NO.: 18-32; Northwest WTP 20 Inch Water Main Extension

### **DEFINITIONS**

All definitions set forth in the General Conditions of the Contract or in other Contract Documents are applicable to the Bidding Documents.

Addenda are written or graphic instruments issued by the Purchasing Department prior to the time and date for receiving Bids that modify or interpret the Bidding Documents by addition, deletion, clarification, or corrections.

Base Bid is complete and properly signed proposal to do the work, or designated portion thereof, for the sums stipulated therein supported by data called for by the Bidding Documents.

Bid An offer, as a price, whether for payment or acceptance. A quotation, specifically given to a prospective purchaser upon its request, usually in competition with other vendors

Bid (Formal or Sealed) A request for firm prices by Advertised Legal Notice. Prices are submitted in sealed envelopes and in conformance with a prescribed format, all of which are opened in public on an appointed hour and date as advertised.

Bid Bond A good faith monetary commitment which a bidder or surety forfeits to the County of the bidder refuses, or is unable to enter into a contract after submitting a bid, or the bidder cannot furnish the required bonds, usually five percent (5%) of the bid proposal price.

Bidder is a firm or individual who submits a Bid to the Owner for the work described in the proposed Contract Documents.

Bidding Documents include the Advertisement/Notice to Bidders, Front End Bid Documents, Contract Agreement, Specifications and Plans including any Addenda issued prior to receipt of Bids.

Contract A delivered agreement between two or more parties, legally binding and enforceable, to perform a specific act or acts or exchange goods for consideration. A purchase order becomes a contract when accepted by a vendor. A unilateral contract is one in which only one party promises performance. A bilateral contract is one in which both parties promise performance.

Contractor An individual or firm having a contract to provide goods, service or construction for a specified price

County St. Johns County, a political subdivision of the State of Florida (F.S. 217.73)

Responsible Bidder A bidder capable of performing in all respects to fulfill the contract requirements. This includes having the ability to perform, the experience, reliability, capacity, credit, facilities and equipment to meet the contractual obligation.

Responsive Bid, Responsive Proposal, or Responsive Reply A bid, proposal, or reply submitted by a responsive and responsible vendor conforming in all material respects to the solicitation.

Specifications A clear, complete and accurate statement of the physical, functional or technical requirements descriptive of an item and if applicable, the procedure to be followed to determine if the requirements are met.

Subcontractor A party who contracts with a prime contractor to perform all or any part of the prime contractor's obligations.

Unit Price is an amount stated in the Bid as a price per unit of measurement for materials or services as described in the contract documents which shall include all labor, materials, equipment and any other item/s essential to accomplish the scope of work of the Unit Price.

### **BIDDER'S REPRESENTATION**

Each Bidder, by marking his Bid, represents that he has read and understands the Bidding and Contract Documents and his Bid is made in accordance herewith: he has visited the Site and has familiarized himself with the local conditions under which the Work is to be performed; and his Bid is based upon the materials, systems and equipment described in the Bidding Documents without exceptions.

### **BIDDING DOCUMENTS**

Bidding documents may be obtained from [www.demandstar.com](http://www.demandstar.com) or SJC Purchasing, in the number and for the purchase sum, if any, as stated in the Advertisement or Invitation - Notice to Bidders. Complete sets of Bidding Documents shall be used in preparing the Bid Proposal. St. Johns County shall not assume any responsibility for errors or misinterpretations resulting from the use of complete or incomplete sets of Bidding Documents. The Owner, in making copies of the Bidding Documents available on the above terms, do so only for the purpose of obtaining bids on the Work and do not confer a license or grant for any other use.

### **INTERPRETATION OR CORRECTION OF BIDDING DOCUMENTS**

Bidders shall promptly notify the Owner of any ambiguity, inconsistency, or error which they may discover upon examination of the Bidding Documents or of the site and local conditions. Bidders requiring clarification of interpretation of the Bidding Documents shall make a written request to the Owner, to reach him at least **fourteen (14) days** prior to the date for receipt of Bids.

An interpretation, correction, or change of the bidding Documents will be made by Addendum. Interpretation, corrections, or changes of the Bidding Documents made in any other manner will not be binding, and Bidders shall not rely upon such interpretation, corrections, and change. No change will be made to the Bidding Documents by the Owner or its Representative **seven (7) days** prior to Bid receiving date, however, the Owner reserves the authority to decrease this time depending on the necessity of such change.

### **SUBSTITUTIONS**

The materials, products and equipment described in the Bidding Documents establish a standard of required function, dimension, appearance and quality to be met by any proposed substitution. No substitution will be considered unless written request for approval has been submitted by the Bidder and has been received by the Owner at least **fourteen (14) days** prior to the date for receipt of Bids. Each such request shall include the name of the material or equipment for which it is to be substituted and a complete description of the proposed substitute, including drawings, cuts, performance and test data any other information necessary for an evaluation. A statement setting forth any changes in other materials, equipment or work that incorporation of the substitute would require shall be included. The burden of proof of the merit of the proposed substitute is upon the proposer. The project director's approval or disapproval of a proposed substitution shall be final.

If County Staff approves any proposed substitution, such approval will be set forth in an Addendum. Bidders shall **not** rely upon approval made in any other manner.

### **DESIGNATED POINT OF CONTACT**

The County's Designated Point of Contact for this Bid is Leigh Daniels, CPPB, Procurement Supervisor, St. Johns County Purchasing Department. Any and all questions and/or inquiries shall be directed to Ms. Daniels, *in writing*, via email at [ldaniels@sjcfl.us](mailto:ldaniels@sjcfl.us) or fax to (904) 209-0155. Bidders shall not contact, lobby, or otherwise communicate with any other County Staff, including members of the Board of County Commissioners, other than the designated representative shown above. Failure to comply with this requirement shall disqualify a bidder from consideration for award, as provided in St. Johns County Purchasing Code 304.6.5 as provided below:

**Vendors shall not contact, lobby, or otherwise communicate with any SJC employee, including any member of the Board of County Commissioners, other than the above referenced individual from the point of advertisement of the Bid until contract(s) are executed by all parties, per SJC Purchasing Code 304.6.5 "Procedures Concerning Lobbying". According to SJC policy, any such communication shall disqualify the vendor, contractor, or consultant from responding to the subject invitation to bid, request for quote, request for proposal, invitation to negotiate, or request for qualifications. St. Johns County reserves the right to accept or reject any or all bids/proposals, waive minor formalities, and to award the bid/proposal that best serves the interests of St. Johns**

County. St. Johns County also reserves the right to award the base bid and any alternate bids in any combination that best suits the needs of the County.

**QUESTIONS**

Any and all questions related to this project shall be directed, *in writing*, to Leigh Daniels, CPPB, Procurement Supervisor, SJC Purchasing Department, via email to [ldaniels@sjcfl.us](mailto:ldaniels@sjcfl.us) or fax to (904) 209-0155. Questions must be submitted, in writing, no later than four o'clock (4:00PM) on Wednesday, December 27, 2017, so that any necessary addenda may be issued in a timely manner. Any questions received after the deadline will not be answered unless previously approved by the SJC Purchasing Manager or other designated County Representative.

**ADDENDA**

Addenda will be distributed to all who are known by the entity responsible for distribution of the complete set of Bidding Documents. Copies of Addenda will be made available for inspection wherever Bidding Documents are on file for that purpose.

Each Bidder shall ascertain prior to submitting a bid, that all issued addenda have been received, and each Bidder **shall** acknowledge receipt, of all issued addenda in the space provided in the Official County Bid Form, and a fully acknowledged copy of each issued addendum must be included in the submitted bid proposal. Failure to provide fully acknowledged copies of each addendum may result in a bid proposal being deemed non-responsive.

**BID SUBMITTAL REQUIREMENTS**

Bids shall be submitted in **TRIPPLICATE** (one (1) original and two (2) copies) on the required forms provided herein. All blanks on the Bid Form shall be filled in by typewriter or manually in blue or black ink. Bidders are not required to submit a copy of this Bid Document with their bid proposals. The bidders are required to submit, at a minimum, the Bid Proposal Attachments listed in this Document.

Bid proposals must be placed in an envelope, sealed and placed in a second envelope or container, plainly marked on the outside addressed to St. Johns County Purchasing Department, with the bidder's return address in top left hand corner and recite: "BID NO: 18-32; Northwest WTP 20 Inch Water Main Extension"

***See Example Below:***

ABC Company, Inc. 123 Aviles Street St. Augustine, FL 32084	St. Johns County Purchasing Department 500 San Sebastian View St. Augustine, FL 32084 <b>BID NO.: XX-XX – SEALED BID FOR SAMPLE PROJECT</b>
---	--

At the end of this document, a sealed Bid mailing label is provided for convenience. Bidders shall affix the provided label to the outside of the sealed envelope/container to submit their Bid.

Bidder shall assume full responsibility for timely delivery at location designated for receipts of Bids. Bids shall be deposited at the designated location prior to the time and date for receipt of Bids indicated in the Advertisement/Notice to Bidders, or any time extension thereof made by Addendum. Bids received after the time and date for receipt of Bids will be returned to the sender unopened.

Oral, telephonic, telegraphic or electronic Bids are invalid and will not receive consideration.

Where so indicated by the makeup of the Bid Form, sums shall be expressed in both words and figures, and in the case of discrepancy between the two, the amount expressed in words shall govern.

Any interlineations, alteration or erasure must be initialed by the signer of the Bid; failure to do so may cause the Bidder's proposal to be considered non-responsive.

Bidder shall make no stipulation on the Bid Form nor qualify his Bid in any manner, to do so will classify the Bid as being

non-responsive, and may result in the Bidder being removed from consideration for award.

Each submitted copy of the Bid Proposal shall include the full legal company name, address, telephone number and legal name of an authorized representative for the Bidder and a statement as to whether the Bidder is a sole proprietor, partnership, corporation, or any other legal entity. Each copy of the submitted Bid shall be signed by the person or persons legally authorized to bind the Bidder to a contract. A Bid by a corporation shall further give the state of incorporation and have the corporation seal affixed.

A Bid submitted by an agent shall have a current Power of Attorney attached certifying agent's authority to bind the Bidder.

### **BID SECURITY**

Each submitted Bid shall be accompanied by a Bid Security, submitted on the Bid Bond Form provided herein, or in the form of a certified or cashier's check, in the amount of five percent (5%) of the Total Lump Sum Bid amount submitted on the Official County Bid Form, pledging that the Bidder will enter into a contract with the Owner on the terms stated in the Bid and will, if required, furnish bonds as described hereunder covering the faithful performance of the Contract and the payment of all obligations arising thereunder. Should the Bidder refuse to enter into such Contract or fail to furnish such bonds to the Owner, if required, the amount of the Bid Security shall be forfeited, not as penalty, but as liquidated damages.

A Bid Security in the form of a certified or cashier's check must be made payable to the Board of County Commissioners of St. Johns County. Bidders submitting a certified or cashier's check as the bid security are not required to submit Attachment "B" – Certificate as to Corporate Principal, or the Bid Bond forms provided herein.

A Bid Security in the form of a Bid Bond shall be written on the form provided herein, with an acceptable surety, and the Attorney-in-Fact who executes the bond on behalf of the surety shall affix to the bond a certified and current copy of his Power of Attorney. Acceptable surety companies are defined herein under "Surety Bond". The Surety Company shall be licensed to do business in the State of Florida and shall be listed by the U.S. Treasury Department. Any Bidder submitting a Bid Security in the form of a Bid Bond must also submit Attachment "B" – Certificate as to Corporate Principal.

The Owner shall have the right to retain the Bid Security of Bidders until either: (a) the Contract is executed and bonds, if required, have been furnished, or (b) the specified time has elapsed so that Bids may be withdrawn, or (c) all Bids have been rejected.

### **BID BOND INSTRUCTIONS**

If a Bidder chooses to submit a Bid Bond on the form provided herein, he must submit the bond as follows:

1. Prepare and submit one (1) original and two (2) copies of the required Bid Bond Forms as shown above
2. Type or print Bidder's and Surety's names in the same language as in the Advertisement, or Invitation to Bid.
3. Affix the Corporate Seal, and type or print the name of the Surety on the line provided and affix its corporate seal.
4. Attach a copy of Surety agent's Power of Attorney, unless the Power of Attorney has been recorded in St. Johns County. If it has been recorded, give the record book and page. If not recorded, the copy of the Power of Attorney must have an original signature of the Secretary or Assistant Secretary of Surety certifying the copy. The Surety's corporate seal must be affixed:

### **BID POSTPONEMENT/CANCELLATION**

The County may, at its sole and absolute discretion, reject any bids that are not submitted in accordance with the terms in this Bid Solicitation. The County may re-advertise this Bid; postpone or cancel, at any time, this Bid process; or waive any irregularities in this Bid or in the proposals received as a result of this Bid.

### **MODIFICATION OR WITHDRAWAL OF BID**

A Bid may not be modified, withdrawn or canceled by the Bidder during the stipulated time period following the time and date designated for the receipt of Bids, and Bidder so agrees in submitting his Bid.

Prior to time and date designated for receipt of Bids, a Bid submitted early may be modified or withdrawn only by notice to the party receiving Bids at the place and prior to the time designated for receipt of Bids.

Such notice shall be in writing over the signature of the Bidder. If by telephone, written confirmation over the signature of

Bidder must be mailed and postmarked on or before the date and time set for receipt of Bids; it shall be so worded as not to reveal the amount of the original Bid.

Withdrawn Bids may be resubmitted up to the time designated for the receipt of Bids provided that they are then fully in conformance with these Instructions to Bidders.

Bid Security shall be in the amount of five percent (5%) of the Bid as modified or resubmitted.

### **COSTS INCURRED BY BIDDERS**

All expenses involved with the preparation and submission of bids to the County, or any work performed in connection therewith, shall be borne by the Bidder(s). No rights of ownership will be conferred until title of the property is transferred to the successful bidder. All fees for copying and reproduction services for items listed herein are nonrefundable.

### **CONSIDERATION OF BIDS**

**Opening of Bids:** Unless stated otherwise in an Addenda to the Advertisement/Notice to Bidders, the properly identified Bids received on time will be opened publicly as specified in the Advertisement and a tabulation of the bid amounts of the Base Bids and major Alternates, if any, will be made available to Bidders. The Bid Tabulation will be posted on the Purchasing Department bulletin board for seventy two (72) hours.

Any bidder, proposer or person substantially and adversely affected by an intended decision or by an term, condition, procedure or specification with respect to any bid, invitation, solicitation of proposals or requests for qualifications, shall file with the Purchasing Department for St. Johns County, a written notice of intent to protest no later than seventy two (72) hours (excluding Saturdays, Sundays and legal holidays for employees of St. Johns County) after the posting either electronically or by other means of the notice of intended action, not of intended award, bid tabulation, publication by posting electronically or by other means of a procedure, specification, term or condition which the person intends to protest, or the right to protest such matter shall be waived. The protest procedures may be obtained from the Purchasing Department and are included in the Owner's Purchasing Manual. All of the terms and conditions of the Owner Purchasing Manual are incorporated by reference and are fully binding.

**Rejection of Bids:** The Owner reserves the right to reject any or all Bids and in particular to reject a Bid not accompanied by any required Bid Security or data required by the Bidding Documents or a Bid in any way incomplete or irregular.

**Acceptance of Bid (Award):** The Owner shall have the right to reject any or all Bids or waive any minor formality or irregularity in any Bid received.

The Owner shall have the right to accept alternates in any order or combination and to determine the low Bidder on the basis of the sum of the Base Bid and/or the Alternates accepted if alternate bids are requested in the Official County Bid Form.

It is the intent of the Owner to award a contract to the lowest responsible Bidder provided the Bid has been submitted in accordance with the requirements of the Bidding Documents, if judged to reasonable, and does not exceed the funds budgeted for the Project.

If the Contract is awarded, it will be awarded within a minimum of ninety (90) days from the date of the Bid opening, or as designated in the Bid Documents.

### **MINIMUM QUALIFICATION OF CONTRACTORS**

Prime bidder must be fully licensed to do business in the State of Florida and be currently licensed as a Certified Underground Utility Contractor or Certified General Contractor in the State of Florida, and provide proof of licensure with the submitted Bid Proposal. Bidders must have successfully completed, as a Prime or Sub-contractor, at least three (3) projects, in the past five (5) years, of similar type, size and dollar value of the project described herein. Each Bidder must submit Attachment "H" Experience of Bidder Form.

Proof of qualifications shall be provided by completing and submitting Attachment "C" – License/Certification List along with a copy of each license and certificate listed. All licenses, certifications and pre-qualifications must be valid and current on the date bids are submitted.

Bidders to whom award of a contract is under consideration shall submit to the County, upon his request, a properly executed

Contractor's Qualification Statement of AIA Document A305, unless such a statement has been previously required and submitted as a prerequisite to the issuance of Bidding Documents.

### **SUB-CONTRACTORS**

Each Bidder shall submit to the County, a list of Subcontractors and major materials suppliers to be used if awarded the contract. A copy of the form, Attachment "D", is provided in the Bidding Documents. If no Subcontractors or major material suppliers are required, so state there on.

Upon request by the County, the successful Bidder shall within seven (7) days thereafter, submit all data required to establish to the satisfaction of the County, the reliability and responsibility of the proposed Subcontractors to furnish and perform the work described in the Sections of the Specifications pertaining to such proposed Subcontractor's respective trades.

Prior to the award of the Contract, the County will notify the Bidder in writing if either the County, after due investigation, has reasonable and substantial objection to any person or organization proposed as a Subcontractor. The Bidder then may, at his option, withdraw his Bid without forfeiture of Bid Security or submit an acceptable substitute at no increase in Bid price. If the Bidder fails to submit an acceptable substitute within seven (7) days of the original notification, the County then may, at his option, disqualify the Bidder, at no cost to the County.

The County reserves the right to disqualify any Contractor, Subcontractor, Vendor, or material supplier due to previously documented project problems, either with performance or quality.

Subcontractors and other persons and organizations proposed by the Bidder and accepted by the County, must be used on the work for which they were proposed and accepted and shall not be changed except with the written approval of the County.

### **PUBLIC CONSTRUCTION BOND**

The Contractor shall be required to obtain and submit a recorded Public Construction Bond covering the faithful performance of the Contract and the payment of all obligations arising thereunder in full amount of the Contract, with such acceptable sureties, secured through the Bidder's usual sources as may be agreeable to the parties. The Contractor shall furnish the required bond, after full execution of the awarded Contract. The Bond shall be released upon satisfactory completion of the project.

### **SURETY BOND**

Acceptable Surety Companies: To be responsible to the Owner as Surety on Bonds, Surety shall comply with the following provisions:

1. Surety must be licensed to do business in the State of Florida;
2. Surety must have been in business and have a record of successful continuous operations for at least three (3) years;
3. Surety shall not have exposed itself to any loss on any one risk in an amount exceeding twenty percent (20%) of its surplus to policyholders;
4. Surety must have fulfilled all of its obligations on all other bonds given to the Owner;
5. Surety must have good underwriting, economic management, adequate reserves for undisclosed liabilities, and net resources for unusual stock and sound investment.

### **Time of Delivery and Form of Bonds**

The Public Construction Bond form will be forwarded to the successful Bidder with his copy of the fully executed contract. **The Public Construction Bond must be recorded after the contract is signed by all parties.** The bidder will have 3 days from receipt of fully executed contract to have the Public Construction Bond recorded. The bidder shall have the Public Construction Bond recorded at the St. Johns County Clerk of Courts office, in St. Augustine, Florida. After the book and page number have been assigned to the bond by the recording person, the Bidder is to obtain from the recording person a certified copy of the recorded bond, and deliver the certified copy to the Owner's Contract Administrator. No work can commence until the required bond and Insurance Certificates have been delivered to the Owner. Upon receipt

of the certified copy of the recorded bond, the Owner may issue a Notice to Proceed.

Unless otherwise specified in the Bid Documents, the bonds shall be written on the form provided herein. The Bidder shall require the Attorney-in-Fact who executes the required bonds on behalf of the Surety to affix thereto a certified and current copy of his Power of Attorney authorizing his firm to act as agent for the Surety in issuing the bonds.

#### **INDEMNIFICATION**

To the fullest extent permitted by law, the Contractor shall indemnify and hold harmless the Owner, its officials, and employees, from and against liability, claims, damages, losses and expenses including attorney's fees arising out of or resulting from performance of the work, provided that such liability, claims, damages, loss or expense is attributable to bodily injury, sickness, disease or death, or to injury to or destruction of tangible property (other than the work itself) including loss of use resulting therefrom, but only to the extent caused in whole or in part, by negligent acts or omissions of the Contractor, a Subcontractor, or anyone directly or indirectly employed by them or anyone for whose acts they may be liable, regardless of whether or not such liability, claim, damage, loss or expense is caused in part by a party indemnified hereunder.

In claims against any person or entity indemnified under this paragraph by an employee of the Contractor, a Subcontractor, anyone directly or indirectly employed by them or anyone for whose acts they may be liable, the indemnification obligation under this shall not be limited by a limitation on amount or type of damages, compensation or benefits payable by or for the Contractor or a Subcontractor under workers' compensation acts, disability benefits acts or other employee benefits acts.

#### **TERMINATION**

Failure on the part of the Contractor to comply with any portion of the duties and obligations under the Contract Agreement shall be cause for termination. If the Contractor fails to perform any aspect of the responsibilities described herein St. Johns County shall provide written notification of any and all items of non-compliance. The Contractor shall then have five (5) consecutive calendar days to correct any and all items of non-compliance. If the items of non-compliance are not corrected, or acceptable corrective action has not been taken within the five (5) consecutive calendar days, the Contract Agreement may be terminated by St. Johns County for cause, upon giving fourteen (14) consecutive calendar days written notice to the Contractor.

The County may terminate the Contract Agreement at any time, without cause, upon thirty (30) days written notice to the Contractor of intention to do so.

If, at any time, the Contract Agreement with the awarded vendor is terminated by the County, whether for cause or for convenience, the County may, at its sole discretion, negotiate with the second lowest, responsible, responsive bidder for the required services in order to enter into a contract with that vendor to prevent a gap in services for the County, if it serves the best interest of the County to do so.

#### **FORM OF AGREEMENT BETWEEN OWNER AND CONTRACTOR**

Form to be used: Unless otherwise provided in the Bidding Documents, the Agreement for Work will be written on the St. Johns County Standard Agreement between Owner and Contractor where the basis of payment is a Stipulated Sum. In the event of a conflict in specifications or contract requirements the more stringent shall apply.

#### **CONTRACT TIME – LIQUIDATED DAMAGES**

The Contractor shall have ten (10) days to return Contract originals from the time the Contractor receives a "Notice of Award". St. Johns County will return a "fully executed" Contract to the Contractor no later than seven (7) days after the return of the executed Contract originals (but no later than seventeen (17) days from the Notice of Award).

The Contractor will furnish a recorded original of the Public Construction Bond three (3) business days after receipt of the fully executed Contract (the Public Construction Bond must be recorded after the Contract is fully executed by all parties including the County Clerk). Upon receipt of the recorded Public Construction Bond, the County will issue a Notice to Proceed. If the Contractor fails to meet any of the dates and timeframes set forth in this section, or fails to execute the Contract, or to provide a Public Construction Bond, the County may elect at its option to consider the Contractor non-responsive and Contract with the next best Bidder.



The work to be performed under this Agreement shall be commenced within **ten (10)** days of the date of the Notice to Proceed, in writing. Construction of the project shall be substantially complete within **Sixty (60)** consecutive calendar days from the date stipulated on the Notice to Proceed. Final completion shall be attained **Thirty (30)** consecutive calendar days from the date of substantial completion.

**Conditions under which Liquidated Damages are Imposed:**

Should the Contractor or, in case of his default, the Surety fail to complete the work within the time stipulated in the contract, or within such extra time as may have been granted by the Owner, the Contractor or, in case of his default, the Surety shall pay to the Owner, not as a penalty but as liquidated damages, the amount so due as determined by the following schedule:

<u>Original Contract Amount</u>	<u>Daily Charge Per Calendar Day</u>
\$50,000 and under.....	\$763 Over
\$50,000 but less than \$250,000.....	\$958
\$250,000 but less than \$500,000.....	\$1,099
\$500,000 but less than \$2,500,000.....	\$1,584
\$2,500,000 but less than \$5,000,000.....	\$2,811
\$5,000,000 but less than \$10,000,000.....	\$3,645
\$10,000,000 but less than \$15,000,000.....	\$4,217
\$15,000,000 but less than \$20,000,000.....	\$4,698
\$20,000,000 and over.....	\$6,323 plus 0.00005 of any amount over \$20 million (Round to nearest whole dollar)

**INSURANCE**

The CONTRACTOR shall not commence work under this Contract until he/she has obtained all insurance required under this section and such insurance has been approved by the COUNTY. All insurance policies shall be issued by companies authorized to do business under the laws of the State of Florida. The CONTRACTOR shall furnish proof of Insurance to the COUNTY prior to the commencement of operations. The Certificate(s) shall clearly indicate the CONTRACTOR has obtained insurance of the type, amount, and classification as required by contract and that no material change or cancellation of the insurance shall be effective without thirty (30) days prior written notice to the COUNTY. Certificates shall specifically include the COUNTY as Additional Insured for all lines of coverage except Workers' Compensation and Professional Liability. A copy of the endorsement must accompany the certificate. Compliance with the foregoing requirements shall not relieve the CONTRACTOR of its liability and obligations under this Contract.

Certificate Holder Address: St. Johns County, a political subdivision of the State of Florida  
500 San Sebastian View  
St. Augustine, FL 32084

The CONTRACTOR shall maintain during the life of this Contract, Comprehensive General Liability Insurance with minimum limits of \$1,000,000 per occurrence, \$2,000,000 aggregate to protect the CONTRACTOR from claims for damages for bodily injury, including wrongful death, as well as from claims of property damages which may arise from any operations under this Contract, whether such operations be by the CONTRACTOR or by anyone directly employed by or contracting with the CONTRACTOR.

The CONTRACTOR shall maintain during the life of the contract, Professional Liability or Errors and Omissions Insurance with minimum limits of \$1,000,000, if applicable.

The CONTRACTOR shall maintain during the life of this Contract, Comprehensive Automobile Liability Insurance with minimum limits of \$2,000,000 combined single limit for bodily injury and property damage liability to protect the CONTRACTOR from claims for damages for bodily injury, including the ownership, use, or maintenance of owned and non-owned automobiles, including rented/hired automobiles whether such operations be by the CONTRACTOR or by anyone directly or indirectly employed by a CONTRACTOR.

The CONTRACTOR shall maintain Umbrella or Excess Liability Insurance covering workers compensation, commercial general liability and business auto liability with minimum limits of liability of \$1,000,000.

The CONTRACTOR shall maintain during the life of this Contract, adequate Workers' Compensation Insurance in at least such amounts as are required by the law for all of its per Florida Statute 440.02.

In the event of unusual circumstances, the County Administrator, or his designee, may adjust these insurance requirements.

**GOVERNING LAWS & REGULATIONS**

The Contractor shall be responsible for being familiar and complying with any and all federal, state, and local laws, ordinances, rules and regulations that, in any manner, affect the work required under this contract. The agreement shall be governed by the laws of the State of Florida and St. Johns County both as to interpretation and performance.

**TAXES**

Project is subject to Federal Excise and Florida Sales Taxes, which must be included in Bidder's proposal.

**FLORIDA TRENCH SAFETY ACT**

Bidders shall complete Certificate of Compliance with Florida Trench Safety Act, in accordance with the requirements of Chapter 553, Florida Statutes. If trenching is not required for this project, state so thereon. Contractor shall be responsible for compliance with all trenching shoring safety requirements.

**END OF SECTION**

**OFFICIAL COUNTY BID FORM  
WITH ATTACHMENTS**

**BID NO: 18-32**

**OFFICIAL COUNTY BID FORM  
ST. JOHNS COUNTY, FLORIDA**

**PROJECT: NORTHWEST WTP 20 INCH WATER MAIN EXTENSION**

**TO: THE BOARD OF COUNTY COMMISSIONERS OF ST. JOHNS COUNTY, FLORIDA**

DATE SUBMITTED: \_\_\_\_\_

**BID PROPOSAL OF**

\_\_\_\_\_  
Full Legal Company Name

\_\_\_\_\_  
Mailing Address

\_\_\_\_\_  
Telephone Number

\_\_\_\_\_  
Fax Number

Bidders: Having become familiar with requirements of the project, and having carefully examined the Bidding Documents and Specifications entitled for Bid No: 18-32, Northwest WTP 20 Inch Water Main Extension in St. Johns County, Florida, the undersigned proposes to furnish all materials, labor and equipment, supervision and all other requirements necessary to comply with the Contract Documents to submit the following Bid Proposal summarized as follows:

**TOTAL LUMP SUM BID PRICE:** (As per plans and specifications)

\$ \_\_\_\_\_  
Total Lump Sum Bid Price (Numerical)

\_\_\_\_\_  
Total Lump Sum Bid Price (Amount written or typed in words) /100 Dollars

Bidder shall insert the Total Lump Sum Bid Price in numerals and in words. Any discrepancy between the two submitted amounts shall be determined by the amount written in words.

During the preparation of the Bid, the following addenda, if any, were received:

No.: \_\_\_\_\_ Date Received:

No.: \_\_\_\_\_ Date Received:

No.: \_\_\_\_\_ Date Received:

We, the undersigned, hereby declare that no person or persons, firm or corporation, other than the undersigned are interested, in this proposal, as principals, and that this proposal is made without collusion with any person, firm or corporation, and we have carefully and to our satisfaction examined the Bid Documents and Project Specifications.

We have made a full examination of the location of the proposed work and the sources of supply of materials, and we hereby agree to furnish all necessary labor, equipment and materials, fully understanding that any quantities shown therewith are approximate only, and that we will fully complete all requirements therein as prepared by the Owner, within the same time limit specified in the Bid Documents as indicated above.

If the Undersigned is notified of the acceptance of this Bid Proposal by the Board within ninety (90) calendar days for the time set for the opening of Bids, the Undersigned further agrees, to execute a contract for the above work within ten (10) days after notice that his Bid has been accepted for the above stated compensation in the form of a Contract presented by the Owner.

The Undersigned further agrees that security in the form of a Bid Bond, certified or cashier's check in the amount of not less than five percent (5%) of Total Lump Sum Bid Price, payable to the Owner, accompanies this Bid; that the amount is not to be construed as a penalty, but as liquidated damages which said Owner will sustain by failure of the Undersigned to execute and deliver the Contract and Bond within ten (10) days of the written notification of the Award of the Contract to him; thereupon, the security shall become the property of the Owner, but if this Bid is not accepted within ninety (90) days of the time set for the submission of Bids, or if the Undersigned delivers the executed Contract upon receipt, the Security shall be returned to the Bidder within seven (7) working days.

**CORPORATE/COMPANY**

Full Legal Company Name: \_\_\_\_\_ (Seal)

By: \_\_\_\_\_  
Signature of Authorized Representative (Name & Title typed or printed)

By: \_\_\_\_\_  
Signature of Authorized Representative (Name & Title typed or printed)

Address: \_\_\_\_\_  
Telephone No.: ( ) \_\_\_\_\_ Fax No.: ( ) \_\_\_\_\_

Email Address for Authorized Company Representative: \_\_\_\_\_  
Federal I.D. Tax Number: \_\_\_\_\_ DUNS #: \_\_\_\_\_  
(If applicable)

**INDIVIDUAL**

Name: \_\_\_\_\_  
(Signature) (Name typed or printed) (Title)

Address: \_\_\_\_\_  
Telephone No.: ( ) \_\_\_\_\_ Fax No.: \_\_\_\_\_  
Email Address: \_\_\_\_\_  
Federal I.D. Tax Number: \_\_\_\_\_

- Submittal Requirements:
- Official County Unit Price Bid Form
  - Attachment "A" – St Johns County Board of County Commissioners Affidavit
  - Attachment "B" – Certificate as to Corporate Principal
  - Attachment "C" – License / Certification List
  - Attachment "D" – List of Proposed Sub-Contractors/Suppliers
  - Attachment "E" – Conflict of Interest Disclosure Form
  - Attachment "F" - Certificate of Compliance with Florida Trench Safety Act
  - Attachment "G" – Proof of Insurance
  - Attachment "H" – Experience of Bidder Form
  - Bid Bond Form
  - Fully Acknowledged Addenda Applicable to this bid

Official County Bid Form, Attachments "A", "B", "C", "D", "E", "F", "G", "H" and Bid Bond must be completed, along with a fully acknowledged copy of each Addendum applicable to this Bid and submitted with each copy of the Bid Proposal. One (1) original and two (2) copies of all required forms must be submitted.

BID NO.: 18-32

ATTACHMENT "A"

**ST. JOHNS COUNTY, BOARD OF COUNTY COMMISSIONERS AFFIDAVIT**

TO: ST. JOHNS COUNTY, BOARD OF COUNTY COMMISSIONERS,  
ST. JOHNS COUNTY, ST. AUGUSTINE, FLORIDA.

At the time the proposal is submitted, the Bidder shall attach to his Bid a sworn statement.

This sworn statement shall be an affidavit in the following form, executed by an officer of the firm, association, or corporation submitting the proposal, and shall be sworn to before a person who is authorized by law to administer oaths.

STATE OF FLORIDA, COUNTY OF ST. JOHNS

Before me, the Undersigned authority, personally appeared \_\_\_\_\_ who being duly sworn, deposes and says he is \_\_\_\_\_ (Title) of the firm of \_\_\_\_\_ Bidder submitting the attached proposal for the services covered by the bid documents for Bid No: 18-32; Northwest WTP 20 Inch Water Main Extension, in St. Johns County, Florida.

The affiant further states that no more that one proposal for the above-referenced project will be submitted from the individual, his firm or corporation under the same or different name, and that such Bidder has no financial interest in the firm of another bidder for the same work. That neither he, his firm, association nor corporation has either directly or indirectly entered into any agreement, participated in any collusion, nor otherwise taken any action in restraint of free competitive bidding in connection with this firm's Bid on the above-described project. Furthermore, neither the firm nor any of its officers are barred from participating in public contract lettings in the State of Florida or any other state.

\_\_\_\_\_  
(Bidder)

By: \_\_\_\_\_  
\_\_\_\_\_  
(Title)

Sworn and subscribed to me this \_\_\_\_\_ day  
of \_\_\_\_\_, 20\_\_\_\_.

Notary Public:  
\_\_\_\_\_  
Signature  
\_\_\_\_\_  
Printed

My commission Expires: \_\_\_\_\_

BIDDER ON ALL COUNTY PROJECTS MUST EXECUTE AND ATTACH THIS AFFADAVIT TO EACH BID.

BID NO.: 18-32

**ATTACHMENT "B"**  
**CERTIFICATES AS TO CORPORATE PRINCIPAL**

I, \_\_\_\_\_, certify that I am the Secretary of the Corporation named as Principal in the attached bond; that \_\_\_\_\_ who signed the said bond on behalf of the Principal, was then of said Corporation; that I know his signature, and his signature hereto is genuine; and that said bond was duly signed, sealed, and attested for and in behalf of said Corporation by authority of it's governing body.

\_\_\_\_\_  
Secretary

\_\_\_\_\_  
Corporate Seal

(STATE OF FLORIDA  
COUNTY OF ST. JOHNS)

Before me, a Notary Public duly commissioned, qualified and acting, personally appeared to me well known, who being by me first duly sworn upon oath, says that he is the Attorney-In-Fact, for the and that he has been authorized by \_\_\_\_\_ to execute the foregoing bond on behalf of the surety named therein in favor of St. Johns County, Florida.

Subscribed and sworn to me this \_\_\_\_\_ day of \_\_\_\_\_, 20\_\_\_\_, A.D.

NOTARY PUBLIC  
State of Florida-at-large

My Commission Expires:

(Attach Power of Attorney to original Bid Bond and Financial Statement of Surety Company)







BID NO.: 18-32

ATTACHMENT "E"

**St. Johns County Board of County Commissioners  
Conflict of Interest Disclosure Form**

Project (RFQ, RFP, BID) Number/Description: Bid No 18-32: Northwest WTP 20 inch Water Main Extension

The term "conflict of interest" refers to situations in which financial or other considerations may adversely affect, or have the appearance of adversely affecting a consultant's/contractor's professional judgment in completing work for the benefit of St. Johns County ("County"). The bias such conflicts could conceivably impart may inappropriately affect the goals, processes, methods of analysis or outcomes desired by the County.

Consultants/Contractors are expected to safeguard their ability to make objective, fair, and impartial decisions when performing work for the benefit of the County. Consultants/Contractors, therefore must there avoid situations in which financial or other considerations may adversely affect, or have the appearance of adversely affecting the consultant's/contractor's professional judgement when completing work for the benefit of the County.

The mere appearance of a conflict may be as serious and potentially damaging as an actual distortion of goals, processes, methods of analysis or outcomes. Reports of conflicts based upon appearances can undermine public trust in ways that may not be adequately restored even when the mitigating facts of a situation are brought to light. Apparent conflicts, therefore, should be disclosed and evaluated with the same vigor as actual conflicts.

It is expressly understood that failure to disclose conflicts of interest as described herein may result in immediate disqualification from evaluation or immediate termination from work for the County.

Please check the appropriate statement:

- I hereby attest that the undersigned Respondent has no actual or potential conflict of interest due to any other clients, contracts, or property interests for completing work on the above referenced project.
- The undersigned Respondent, by attachment to this form, submits information which may be a potential conflict of interest due to other clients, contracts or property interests for completing work on the above referenced project.

Legal Name of Respondent: \_\_\_\_\_

Authorized Representative(s) :	_____	_____
	Signature	Print Name/Title
	_____	_____
	Signature	Print Name/Title

**BID NO.: 18-32**

**ATTACHMENT "F"**

**CERTIFICATE OF COMPLIANCE WITH FLORIDA TRENCH SAFETY ACT**

Bidder acknowledges that he is solely responsible for complying with the Florida Trench Safety Act (ACT) and Occupational Safety and Health Administrations excavation safety standard 29 CFR 1926.650 (Subpart P as amended) and the St. Johns County Trenching and Excavation Safety Program. If there is a conflict between the ACT and the St. Johns County Trenching and Excavation Safety Program, the more stringent requirement would apply. Bidder further acknowledges that included in the various items of the proposal and in the Total Bid Price are costs for complying with the Florida Trench Safety Act (90-96, Laws of Florida) effective October 1, 1990 and the Occupational Safety and Health Administrations excavation safety standard.

By: \_\_\_\_\_

\_\_\_\_\_  
Bidder

\_\_\_\_\_  
Date

\_\_\_\_\_  
Authorized Signature

**BID NO.: 18-32**

**ATTACHMENT "G"**

**CERTIFICATE OF INSURANCE**

INSERT CERTIFICATE OF INSURANCE HERE

BID NO.: 18-32

ATTACHMENT "H"

**EXPERIENCE OF BIDDER**

Bidder acknowledges that he is fully licensed to perform work in the STATE OF FLORIDA.

The Bidder shall provide the following information regarding experience within the past five (5) years of this solicitation. Bidder must demonstrate the successful completion of three (3) projects of similar complexity, nature, size, and dollar amount of project.

Any material misrepresentation, as determined by the County, shall result in disqualification.

By: \_\_\_\_\_  
Bidder Date  
\_\_\_\_\_  
Authorized Signature

DATE OF CONTRACT	CLIENT'S NAME, ADDRESS, PHONE AND EMAIL	CONTRACT AMOUNT	PROJECT AND LOCATION

Do you have any similar work in progress at this time? \_\_\_\_\_ Yes \_\_\_\_\_ No

Length of time in business: \_\_\_\_\_ Years

Is your company currently involved in any active litigation? \_\_\_\_\_ If Yes, explain: \_\_\_\_\_

Has your company ever been sued? \_\_\_\_\_ If Yes, explain and/or submit court decision or judgment, as applicable: \_\_\_\_\_

BID NO.: 18-32

**BID BOND**

STATE OF FLORIDA  
COUNTY OF ST. JOHNS

KNOW ALL MEN BY THESE PRESENTS, that \_\_\_\_\_ as Principal, and as Surety, are held and firmly bound unto St. Johns County, Florida, in the penal sum of Dollars (\$ \_\_\_\_\_) lawful money of the United States, we bind ourselves, our heirs, executors, administrators, and successors, jointly and severally, firmly by these presents.

THE CONDITION OF THIS OBLIGATIONS IS SUCH that whereas the Principal has submitted the accompanying Bid, dated \_\_\_\_\_, 20\_\_.

For  
**NORTHWEST WTP 20 INCH WATER MAIN EXTENSION**  
St. Johns County, Florida

NOW THEREFORE,

- (a) If the Principal shall not withdraw said Bid within ninety (90) days after Bid Award date, and shall within ten (10) days after prescribed forms are presented to him for signature, enter into a written Contract with the County in accordance with the Bid as accepted, and give Bond with good and sufficient Surety or Sureties, as may be required, for the faithful performance and proper fulfillment of such Contract, then the above obligations shall be void and of no effect, otherwise to remain in full force and virtue.
- (b) In the event of the withdrawal of said Bid within the period specified, or the failure to enter into such Contract and give such Bond within the time specified; if the Principal shall pay the County the difference between the amount specified, in said Bid and the amount for which the County may procure the required Work and supplies, if the latter amount be in excess of the former, then the above obligations shall be void and of no effect, otherwise to remain in full force and virtue.

IN WITNESS WHEREOF, the above bounded parties have executed this instrument under their several seals, this day of \_\_\_\_\_ A.D., 20\_\_, the name and corporate seal of each corporate party being hereto affixed and these presents duly signed by its undersigned representative, pursuant to authority of its governing body.

**BID NO.: 18-32**

**WITNESSES:**

(If Sole Ownership or Partnership two (2) Witnesses required).  
(If Corporation, Secretary only will attest and affix seal).

**WITNESSES:**

---

---

---

\_\_\_\_\_  
**PRINCIPAL:**

\_\_\_\_\_  
**NAME OF FIRM:**

\_\_\_\_\_  
**SIGNATURE OF AUTHORIZED OFFICER (AFFIX SEAL)**

\_\_\_\_\_  
**TITLE**

\_\_\_\_\_  
**BUSINESS ADDRESS**

\_\_\_\_\_  
**CITY STATE**

**WITNESS:**

---

\_\_\_\_\_  
**SURETY:**

\_\_\_\_\_  
**CORPORATE SURETY**

\_\_\_\_\_  
**ATTORNEY-IN-FACT (AFFIX SEAL)**

\_\_\_\_\_  
**BUSINESS ADDRESS**

\_\_\_\_\_  
**CITY STATE**

\_\_\_\_\_  
**NAME OF LOCAL INSURANCE AGENCY**



**SEALED BID MAILING LABEL**

**BID NO: 18-32  
NORTHWEST WTP 20 INCH WATER MAIN EXTENSION**

**Cut along the outer border and affix this label  
to your sealed bid envelope to identify it as a  
"Sealed BID"**

<b>SEALED BID • DO NOT OPEN</b>	
<b>SEALED BID NO.:</b>	<b>BID NO: 18-32</b>
<b>BID TITLE:</b>	<b>Northwest WTP 20 Inch Water Main Extension</b>
<b>DUE DATE/TIME:</b>	<b>By 2:00PM – January 10, 2018</b>
<b>SUBMITTED BY:</b>	Company Name
	Company Address
	Company Address
<b>DELIVER TO:</b>	St. Johns County Purchasing Dept. ATTN: Leigh Daniels 500 San Sebastian View St. Augustine FL 32084



**END OF DOCUMENT**