

RESOLUTION NO. 2019- 402

**A RESOLUTION BY THE BOARD OF COUNTY COMMISSIONERS OF ST. JOHNS COUNTY, FLORIDA, APPROVING THE TERMS, CONDITIONS, PROVISIONS, AND REQUIREMENTS OF A DEVELOPER AGREEMENT FOR IMPROVEMENTS TO SR 313 AT US-1 WITH CORDOVA PALMS INVESTMENT, LLC (DEVELOPER); AUTHORIZING THE CHAIR, COUNTY ADMINISTRATOR, OR DESIGNEE, TO EXECUTE THE DEVELOPER AGREEMENT ON BEHALF OF ST. JOHNS COUNTY (COUNTY); AND AMENDING THE FISCAL YEAR 2020 TRANSPORTATION TRUST FUND BUDGET TO RECEIVE UNANTICIPATED REVENUE, AND AUTHORIZE ITS EXPENDITURE BY THE ENGINEERING DEPARTMENT.**

**RECITALS**

**WHEREAS**, the Cordova Palms Planned Unit Development (Ordinance 2016-46) is required as part of the development, to construct State Road 313 from US-1 to the project entrance;

**WHEREAS**, State Road 313 will provide a bypass around the west side of St. Augustine and is currently the County's highest transportation priority; and

**WHEREAS**, The State Legislature allocated \$3,700,000.00 to St. Johns County for improvements to State Road 313 at US-1 as a local transportation project through the Florida Department of Transportation (FDOT) through Chapter 2019-20, Laws of Florida, General Appropriations Act Line 1989A; and

**WHEREAS**, this Developer Agreement is companion to a State-Funded Grant Agreement between the County and FDOT for the \$3.7 million allocated for the SR 313 at US-1 improvements; and

**WHEREAS**, the purpose of this Developer Agreement with Cordova Palms Investment, LLC, is for the developer to cover any cost over-runs or any costs not reimbursed by FDOT for the construction of State Road 313 at US-1, as well as any Construction, Engineering, and Inspection (CEI) costs associated with the Project; and

**WHEREAS**, the purpose of this Agreement is for the County to be reimbursed for any costs associated with the construction of State Road 313 at US-1; and

**WHEREAS**, the funds for this agreement are for construction costs of the State Road 313 improvements within the US-1 right-of-way and does not require matching funds from St. Johns County; and

**WHEREAS**, entering into this Developer Agreement, and recognizing and appropriating the funds into the 2020 Fiscal Year Budget is in the best interest of the public; and

**WHEREAS**, the Project is in the best interest of the County for the health, safety and welfare of its citizens.

**NOW, THEREFORE BE IT RESOLVED BY THE BOARD OF COUNTY COMMISSIONERS OF ST. JOHNS COUNTY, FLORIDA**, as follows:

Section 1. The above Recitals are incorporated by reference into the body of this Resolution, and such Recitals are adopted as finds of fact.

Section 2. The Board of County Commissioners hereby approves the terms, conditions, provisions, and requirements of the Developer Agreement for Improvements to SR 313 at US-1 with Cordova Palms Investment, LLC, and authorizes the Chair, the County Administrator, or designee, to execute the Developer Agreement on behalf of the County for the purposes mentioned above and in substantially the form and format as attached.

Section 3. The Board of County Commissioners recognizes and appropriates unanticipated revenue received pursuant to the Developer Agreement into Transportation Trust Fund and authorizes its expenditure by the St. Johns County Engineering Department.

Section 4. To the extent that there are typographical and/or administrative errors that do not change the tone, tenor, or concept of this Resolution, then this Resolution may be revised without subsequent approval by the Board of County Commissioners.

**PASSED AND ADOPTED** by the Board of County Commissioners of St. Johns County, Florida, this 19<sup>th</sup> day of November, 2019.

**BOARD OF COUNTY COMMISSIONERS  
OF ST. JOHNS COUNTY, FLORIDA**

By:   
Jeb S. Smith, Chairman

ATTEST: Hunter S. Conrad, Clerk

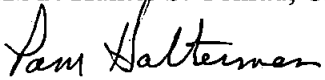
By:   
Deputy Clerk

RENDITION DATE 11/21/19



DEVELOPER AGREEMENT  
FOR  
IMPROVEMENTS TO SR 313 AT US-1

This DEVELOPER AGREEMENT for Improvements to SR 313 at US1 is dated this \_\_\_\_ of \_\_\_\_\_, 2019, by and between St. Johns County, a political subdivision of the State of Florida (the "County"), and Cordova Palms Investment, LLC. ("Developer").

Recitals

- A. Developer is the owner of those certain properties in St. Johns County, Florida identified as Parcel Identification Numbers: 072520 0000, 072570 0000; 072590 0000; and 074290 0000 and identified as the Cordova Palms Planned Unit Development ("Cordova Palms PUD"), approved by St. Johns County Ordinance 2016-46, as amended.
- B. Pursuant to the PUD and that certain Concurrency and Impact Fee Agreement dated April 6, 2018 and recorded in BK 4531, PG 1198, St. Johns County, FL ("Impact Fee Agreement"), Developer seeks to improve and construct State Road 313 (SR 313) from its intersection from US-1 to the Cordova Palms PUD Entrance.
- C. SR. 313 will provide a bypass around the west side of St. Augustine and is currently the County's highest transportation priority.
- D. During the course of permitting efforts by Developer of SR 313, the Florida Department of Transportation required design changes. As a result of those design changes, \$3,700,000.00 was allocated to St. Johns County for improvements to SR 313 at US-1 in the Fiscal Year 2019-2020 General Appropriations Act, Chapter 2019-115, Laws of Florida.
- E. The SR 313 at US-1 Improvements are those intersection improvements east of the Florida East Coast railroad tracks within the existing US-1 right-of-way as more particularly described in Exhibit "A" (the "SR 313 at US-1 Improvement").
- F. The estimated cost of construction of the SR 313 at US-1 Improvement is approximately \$3,677,408.00.
- G. The estimated cost for Construction, Engineering, and Inspection Services is approximately \$485,000.00.
- H. The estimated cost of utility relocation and accommodation is approximately \$334,000.00.
- I. St. Johns County desires to enter or has entered into a State-Funded Grant Agreement with the Florida Department of Transportation (FDOT) for FDOT to reimburse the County up to \$3,700,000.00 for design and construction of the SR 313 at US-1 Improvements.
- J. It is the purpose of this Agreement for the County to facilitate the construction of the SR 313 at US-1 Improvements with no cost to St. Johns County.
- K. Based on the foregoing, it is in the best interest of both parties, as well as the welfare and safety of the general public, for the County and Developer to enter into this Agreement for improvements to SR 313 at US-1 and for the Developer to pay for any and all costs and expenses, including Construction, Engineering, & Inspection (CEI) services costs, in

excess of \$3,700,000 or any and all costs and expenses, including CEI services costs, not reimbursed to the County by the Florida Department of Transportation.

- L. It is in the best interest of both parties for Developer to pay all Construction, Engineering & Inspection (CEI) Service costs and utility accommodation costs associated with this project that are not reimbursed to the County by the FDOT. Pursuant to the Impact Fee Agreement, Developer, by amendment to the Impact Fee Agreement, will be entitled to an increase in the Road Impact Fee credit amount to appropriately reflect any costs in excess of the Probable Construction Cost of the SR 313/US Intersection in Exhibit C-4 of the Impact Fee Agreement incurred by Developer associated with the SR 313 at US-1 Improvements.

**Now, therefore,** in consideration of \$10 and other good and valuable consideration, the receipt of which is hereby acknowledged, and the mutual benefits derived from this Agreement, the parties agree to the following:

1. Recitals. The above recitals are true and correct and incorporated by reference into this Agreement as findings of fact.
2. Purpose. The purpose of this Agreement is to facilitate the construction of the SR 313 at US-1 improvements with no cost to St. Johns County.
3. Developer Obligations.
  - a. Cost Overruns and CEI services costs. Until completion of the SR 313 at US-1 improvements and until County is fully reimbursed, Developer shall unconditionally fund any and all costs, including Construction, Engineering, & Inspections (CEI) services costs, associated with the design and construction of the SR 313 at US-1 Improvement for any amounts in excess of \$3,700,000.00 or for any amounts incurred by the County that are not reimbursable by FDOT. Developer shall promptly process and issue payment of invoices submitted by the County for Additional Costs pursuant to subsection 4.b and section 5, below. For any such amounts paid by Developer under this Developer Agreement, Developer, by amendment to the Impact Fee Agreement, will be entitled to an increase in the Road Impact Fee credit amount under the Impact Fee Agreement to appropriately reflect any such costs in excess of the Probable Construction Cost for the SR 313/US 1 Intersection in Exhibit C-4 of the Impact Fee Agreement incurred by Developer associated with the SR 313 at US-1 Improvements.
  - b. Permits. Developer shall be responsible for designing, seeking, and obtaining all necessary permits federal, state and local development permits for the SR 313 at US-1 Improvements.
  - c. Performance Security. Developer shall deliver to County before commencement of construction, a letter of credit, escrow agreement or other security approved by the

Office of the County Attorney in an amount totaling \$794,000.00 to ensure completion of the SR 313 at US-1 Improvement. The County shall be the named beneficiary or obligee on the security.

4. County Obligations.

- a. Construction of the SR 313 at US-1 Intersection. County shall commence or cause to be commenced the construction of the SR 313 at US-1 Improvement. Commencing construction shall mean execution by County of a contract or contracts with a FDOT prequalified contractor for construction of the SR 313 at US-1 Improvement. Construction of the SR 313 at US-1 Improvements shall be at the County's direction and approval, but with good faith coordination with Developer. The County shall proceed expeditiously with, and shall notify Developer before, commencement of construction of the SR 313 at US-1 Improvements.
- b. Notice for Additional Costs. The County shall promptly notify Developer when the total amount of costs and expenses incurred by the County has reached in excess of \$3.7 million. The County shall promptly notify Developer of any costs of the SR 313 at US-1 Improvement that is not reimbursable by the Florida Department of Transportation. Until completion of the SR 313 at US-1 Improvement and until County is fully reimbursed, County shall submit periodic progress payment requests to Developer, along with an invoice and supporting documentation for such progress payments pursuant to section 5, below.
- c. Appropriation of Funds. The County authorizes the appropriation of any funds or moneys received from the Developer to the SR 313 at US-1 Improvement.

5. Reimbursement Procedures. County shall be reimbursed by Developer according to the following procedures:

- a. The County shall submit periodic progress payments to Developer and Developer. County shall include an invoice, progress report, and supporting documentation.
- b. Developer shall reimburse County for the requested costs within **15 days** of receipt of the periodic progress payment.

6. Completion. Completion of the SR 313 at US-1 Improvement shall be defined as the acceptance of the SR 313 at US-1 Improvements by FDOT in accordance with FDOT closeout and acceptance process.

7. Availability of Funds. The County's and Developer's performance under this Agreement is contingent upon the appropriation of sufficient funds for the purpose by the Board of County Commissioners. Pursuant to the requirements of section 129.07, Florida Statutes, funds expended by the County under this Agreement shall not exceed the amount

appropriated in the County's budget for that purpose. Nothing in this Agreement shall create any obligation on the part of the Board to appropriate funds for the County's performance under this Agreement in any given fiscal year.

8. Notice. All notices to the County shall be delivered either by hand (receipt of delivery required) or by certified mail to:

County Administrator  
500 San Sebastian View  
St. Augustine, FL 32084

Copy: Office of the County Attorney  
500 San Sebastian View  
St. Augustine, FL 32084

All notices to Developer shall be delivered either by hand (receipt of delivery required) or by certified mail to:

Cordova Palms Investment, LLC  
77 Almeria Street  
St. Augustine, FL 32084

Copy: D.R. Repass  
D.R. Repass, P.A.  
111 Solana Road  
Suite B  
Ponte Vedra Beach, FL 32082.

All other correspondence not classified as notices may be delivered, disseminated, or submitted by any means acceptable to both parties, specifically including facsimile, email, or text messaging.

9. Default and Remedies. In the event of a breach of this Agreement by one party, the other party shall have all the rights and remedies available at law or in equity, unless otherwise described herein. As to any material breach by either party under this Agreement, the breaching party shall proceed in good faith to use all reasonable action to cure such breach. In the event the breaching party fails to cure, the non-breaching party may proceed at law or in equity to enforce its rights under this Agreement, including the right to seek specific performance and mandamus or to terminate this Agreement and recover damages. Each of the parties to this Agreement shall promptly give the other party written notice of any defaults to this Agreement and shall allow the defaulting party thirty (30) days from the date of this receipt of such notice within which to cure any such defaults.

10. Assignment. This Agreement may be assigned by the Developer to any purchaser of the Cordova property upon written consent of the County, which consent shall not be unreasonably withheld.
11. Compliance with All Federal, State, and Local Laws. The parties shall comply with all applicable requirements of federal, state, and local law in their performance of this Agreement. To the extent that any party must obtain any permit, license, or approval in order to perform its obligations under this Agreement, that party shall be responsible for obtaining such permit, license, or approval at its own expense.
12. Third Party Beneficiaries. This Agreement does not confer or infer third party beneficiary status or interest to any other person or entity.
13. Relationship of the Parties. This Agreement shall not be construed to create any agency relationship, partnership, association, or joint venture between the County and the School Board.
14. Force Majeure. The County shall not be held in default, breach, violation, or noncompliance with the terms, provisions, conditions, or requirements of this Agreement, nor suffer any enforcement or penalty relating thereto (including revocation, cancellation, or termination of this Agreement) where such noncompliance or alleged default, breach, or violation occurred and/or was caused by the circumstances beyond the County's control, including without limitation acts of God, fire, flood, natural disasters, or otherwise; provided, however, the County shall use its best efforts to overcome such force majeure event.
15. Non-Waiver. The failure of either party to insist upon the strict performance or compliance with any provision of this Agreement shall not constitute a waiver or relinquishment of such provision on any subsequent occasion, and all such provisions shall remain in effect unless waived or relinquished in writing.
16. Governing Law and Venue. This Agreement shall be governed in accordance with the laws of the state of Florida. Venue for action related to this Agreement shall lie exclusively in St. Johns County, Florida.
17. Dispute Resolution. If a dispute arises with respect to any right or duty arising under this Agreement, the parties agree to meet to pursue resolution through negotiation or other appropriate dispute resolution process, including but not limited to that established in chapter 164, Florida Statutes, before resorting to litigation.
18. Severability. If any part of this Agreement, or the application thereof, is declared illegal, void, unconstitutional, invalid, or otherwise unenforceable for any reason, such part shall be severable, and the remaining portions of the Agreement shall remain in effect.

19. Entire Agreement. The parties acknowledge that this Agreement, together with all exhibits and documents incorporated herein, contains the complete agreement and understanding between the parties. No representations or promises have been made except those that are specifically provided herein. This Agreement supersedes all prior and contemporaneous agreements, understandings, representations, and warranties, whether oral or written, relating to the subject matter of this Agreement. Any amendment to this Agreement shall be in writing and executed by a duly authorized representative of each party.
20. Section Headings. All section and descriptive headings in this Agreement are intended for convenience only and shall not be taken into consideration in any construction or interpretation of this Agreement or any of its provisions.
21. Authority to Execute. Each party covenants that it has the lawful authority to enter into this Agreement and has authorized the execution of this Agreement by the party's authorized representative.
22. Counterparts. This Agreement may be executed in any number of counterparts, including facsimile, each of which shall be deemed to be an original and all of which together shall constitute one and the same instrument.
23. Access to Records. The access to, disclosure non-disclosure, or exemption of records, data, documents, and/or materials, associated with this Agreement shall be subject to the applicable provisions of the Florida Public Records Law (Chapter 119, Florida, Statutes) and other applicable State or Federal law. Access to such public records may not be blocked, thwarted, and/or hindered by placing the public records in the possession of a third party, or an unaffiliated party.
24. Effective Date. This Agreement shall become effective upon filing a copy executed by both parties with the Clerk of the Circuit Court of St. Johns County.



IN WITNESS WHEREOF, the parties have hereunto set their hands and seals the day and year written above.

COUNTY

Signed, witnessed, executed and acknowledged on this \_\_\_\_\_ day of \_\_\_\_\_

Signed, Sealed and Delivered  
in the presence of:

**St. Johns County, Florida**, a  
political subdivision of the State of Florida,

\_\_\_\_\_  
Print Name \_\_\_\_\_

\_\_\_\_\_  
By: Michael D. Wanchick  
County Administrator

\_\_\_\_\_  
Print Name \_\_\_\_\_

Legally Sufficient \_\_\_\_\_

Attest:

By: \_\_\_\_\_  
Hunter S. Conrad  
Clerk of Court

DEVELOPER

Signed, Sealed and Delivered  
in the presence of:

**Cordova Palms Investment, LLC a  
Florida Limited Liability Company,**

\_\_\_\_\_  
Print Name \_\_\_\_\_

\_\_\_\_\_  
By: \_\_\_\_\_  
Its: \_\_\_\_\_

\_\_\_\_\_  
Print Name \_\_\_\_\_

Exhibit A to Agreement

CORDOVA PALMS

ALSOP COMPANIES, LLC

ST. JOHNS COUNTY  
STATE ROAD NO. 5 (U.S. 1)

INDEX OF ROADWAY PLANS

SHEET NO.	SHEET DESCRIPTION
1	KEY SHEET
2	SIGNATURE SHEET
3 - 4	DRAINAGE MAP
5 - 7	TYPICAL SECTIONS
8	PROJECT LAYOUT
9 - 12	GENERAL NOTES
13 - 24	ROADWAY PLAN & PROFILE
25 - 26	INTERSECTION GRADING DETAIL
27	DRAINAGE STRUCTURES
28	ROADWAY SOIL SURVEY
29 - 38	CROSS SECTIONS
39	PARCEL 10 - SWMF 9-BID ALTERNATE
40 - 41	STORMWATER POLLUTION PREVENTION PLAN
42 - 79	TEMPORARY TRAFFIC CONTROL PLANS
80 - 83	UTILITY ADJUSTMENT PLAN
84 - 87	WATER AND SEWER PLANS
88 - 95	SIGNING & PAVEMENT MARKING PLAN
97 - 101	SIGNALIZATION PLAN
102 - 103	GUIDE SIGN WORKSHEET

SR 313 (CORDOVA PALMS PARKWAY)  
ROADWAY DESIGN STA. 487+73.50 (0.0' RT.) =  
FLORIDA EAST COAST RAILWAY (FEC)  
FEC VAL-MAP STA. 1562+02.70  
SR 313 (CORDOVA PALMS PARKWAY)  
AAR/IDOT# 273276T  
RR HP: 29+3041'

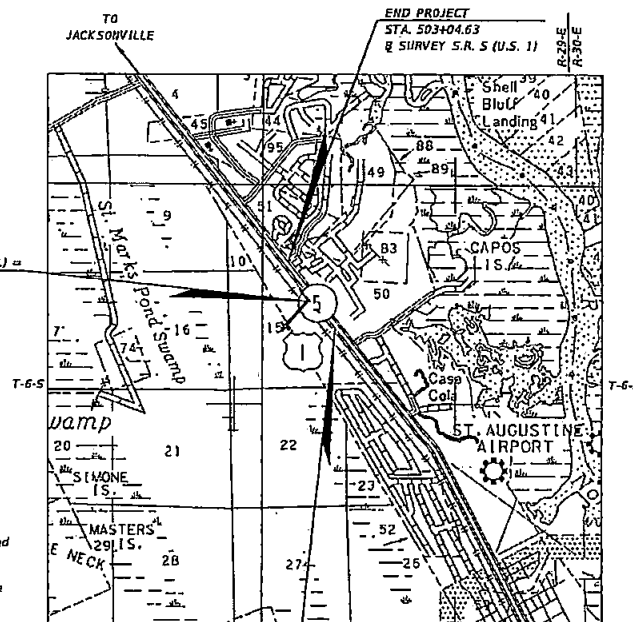

BEGIN PROJECT  
STA. 444+23.45  
@ SURVEY S.R. 5 (U.S. 1)

TO  
ST. AUGUSTINE  
@ SURVEY S.R. 5 (U.S. 1)

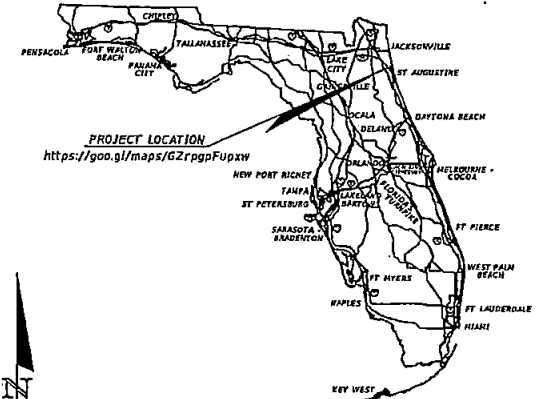

ROADWAY SHOP DRAWINGS  
TO BE SUBMITTED TO:  
BRIAN LANDEWEER, P.E.  
14775 OLD ST. AUGUSTINE ROAD  
JACKSONVILLE, FLORIDA 32258

PLANS PREPARED BY:  
ENGLAND-THIMS & MILLER, INC.  
14775 OLD ST. AUGUSTINE ROAD  
JACKSONVILLE, FLORIDA 32258  
TEL: (904) 642-8990  
CA-0002584 LC-0000316



NOTE: THE SCALE OF THESE PLANS MAY HAVE CHANGED DUE TO REPRODUCTION.

ROADWAY PLANS  
ENGINEER OF RECORD: BRIAN LANDEWEER, P.E.  
P.E. NO.: 62168

FINAL PLANS  
SEPTEMBER 2019

SHEET NO.
1

THE OFFICIAL RECORD OF THIS SHEET IS THE ELECTRONIC FILE DIGITALLY SIGNED AND SEALED UNDER RULE 61G15-23.004, F.A.C.

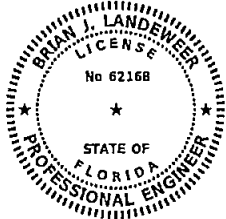

THIS ITEM HAS BEEN DIGITALLY SIGNED AND SEALED BY:  
 Brian Landeweer  
 ON THE DATE ADJACENT TO THE SEAL.  
 PRINTED COPIES OF THIS DOCUMENT ARE NOT CONSIDERED SIGNED AND SEALED AND THE SIGNATURE MUST BE VERIFIED ON ANY ELECTRONIC COPIES.

ENGLAND-THIMS & MILLER, INC.  
 14775 Old St. Augustine Road  
 Jacksonville, FL 32258  
 TEL: (904) 642-8990  
 CA - 00002584 LC - 0000316  
 BRIAN J. LANDEWEER, P.E.  
 P.E. LICENSE NO. 62168

THE ABOVE NAMED PROFESSIONAL ENGINEER SHALL BE RESPONSIBLE FOR THE FOLLOWING SHEETS IN ACCORDANCE WITH RULE 61G15-23.004, F.A.C.

**ROADWAY PLANS**

SHEET NO.	SHEET DESCRIPTION
1	KEY SHEET
2	SIGNATURE SHEET
3 - 4	DRAINAGE MAP
5 - 7	TYPICAL SECTIONS
8	PROJECT LAYOUT
9 - 12	GENERAL NOTES
13 - 24	ROADWAY PLAN & PROFILE
25 - 26	INTERSECTION GRADING DETAIL
27	DRAINAGE STRUCTURES
29 - 38	CROSS SECTIONS
39	PARCEL 10 - SWMF 9 BID ALTERNATE
40 - 41	STORMWATER POLLUTION PREVENTION PLAN
42 - 79	TEMPORARY TRAFFIC CONTROL PLANS
80 - 83	UTILITY ADJUSTMENT PLAN
88 - 96	SIGNING & PAVEMENT MARKING PLAN
102 - 103	GUIDE SIGN WORKSHEET

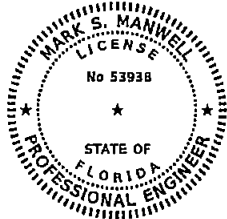

THIS ITEM HAS BEEN DIGITALLY SIGNED AND SEALED BY:  
 Digital Signature:  
 Mark Scott Manwell, P.E.  
 2019.09.20 15:32:19 -04'00'  
 ON THE DATE ADJACENT TO THE SEAL.  
 PRINTED COPIES OF THIS DOCUMENT ARE NOT CONSIDERED SIGNED AND SEALED AND THE SIGNATURE MUST BE VERIFIED ON ANY ELECTRONIC COPIES.

ENGLAND-THIMS & MILLER, INC.  
 14775 Old St. Augustine Road  
 Jacksonville, FL 32258  
 TEL: (904) 642-8990  
 CA - 00002584 LC - 0000316  
 MARK S. MANWELL, P.E.  
 P.E. LICENSE NO. 53938

THE ABOVE NAMED PROFESSIONAL ENGINEER SHALL BE RESPONSIBLE FOR THE FOLLOWING SHEETS IN ACCORDANCE WITH RULE 61G15-23.004, F.A.C.

**ROADWAY PLANS**

SHEET NO.	SHEET DESCRIPTION
2	SIGNATURE SHEET
97 - 99	SIGNALIZATION PLAN

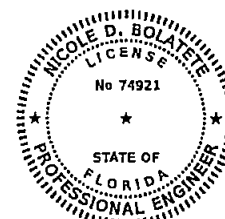

THIS ITEM HAS BEEN DIGITALLY SIGNED AND SEALED BY:  
 Nicole D Bolatete  
 2019.09.20 15:09:20 -04'00'  
 ON THE DATE ADJACENT TO THE SEAL.  
 PRINTED COPIES OF THIS DOCUMENT ARE NOT CONSIDERED SIGNED AND SEALED AND THE SIGNATURE MUST BE VERIFIED ON ANY ELECTRONIC COPIES.

ENGLAND-THIMS & MILLER, INC.  
 14775 Old St. Augustine Road  
 Jacksonville, FL 32258  
 TEL: (904) 642-8990  
 CA - 00002584 LC - 0000316  
 NICOLE D. BOLATETE, P.E.  
 P.E. LICENSE NO. 74921

THE ABOVE NAMED PROFESSIONAL ENGINEER SHALL BE RESPONSIBLE FOR THE FOLLOWING SHEETS IN ACCORDANCE WITH RULE 61G15-23.004, F.A.C.

**ROADWAY PLANS**

SHEET NO.	SHEET DESCRIPTION
2	SIGNATURE SHEET
84 - 87	WATER AND SEWER PLANS

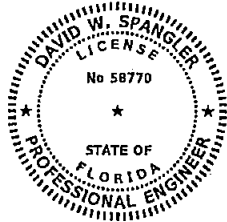

THIS ITEM HAS BEEN DIGITALLY SIGNED AND SEALED BY:  
 David W Spangler  
 2019.09.20 14:45:46 -04'00'  
 ON THE DATE ADJACENT TO THE SEAL.  
 PRINTED COPIES OF THIS DOCUMENT ARE NOT CONSIDERED SIGNED AND SEALED AND THE SIGNATURE MUST BE VERIFIED ON ANY ELECTRONIC COPIES.

ECS Florida, LLC  
 7064 Davis Creek Road  
 Jacksonville, FL 32256  
 TEL: (904) 880-0960  
 CA - 00000998  
 DAVID W. SPANGLER, P.E.  
 P.E. LICENSE NO. 58770

THE ABOVE NAMED PROFESSIONAL ENGINEER SHALL BE RESPONSIBLE FOR THE FOLLOWING SHEETS IN ACCORDANCE WITH RULE 61G15-23.004, F.A.C.

**ROADWAY PLANS**

SHEET NO.	SHEET DESCRIPTION
2	SIGNATURE SHEET
28	ROADWAY SOILS SURVEY
101	REPORT OF SPT BORINGS FOR STRUCTURE

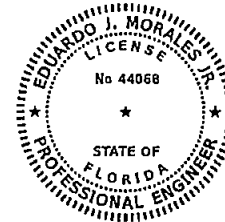

THIS ITEM HAS BEEN DIGITALLY SIGNED AND SEALED BY:  
 Ed J Morales Jr.  
 2019.09.20 14:16:05 -04'00'  
 ON THE DATE ADJACENT TO THE SEAL.  
 PRINTED COPIES OF THIS DOCUMENT ARE NOT CONSIDERED SIGNED AND SEALED AND THE SIGNATURE MUST BE VERIFIED ON ANY ELECTRONIC COPIES.

MORALES CONSULTING ENGINEERS, INC.  
 3832-010 Baymeadows Road  
 Jacksonville, FL 32217  
 TEL: (904) 434-4366  
 CA - 00030712  
 EDUARDO J. MORALES JR., P.E.  
 P.E. LICENSE NO. 44068

THE ABOVE NAMED PROFESSIONAL ENGINEER SHALL BE RESPONSIBLE FOR THE FOLLOWING SHEETS IN ACCORDANCE WITH RULE 61G15-23.004, F.A.C.

**ROADWAY PLANS**

SHEET NO.	SHEET DESCRIPTION
2	SIGNATURE SHEET
100	HAST ARM DATA TABLE

REVISIONS			
DATE	DESCRIPTION	DATE	DESCRIPTION



Enland-Thims & Miller, Inc.  
 14775 Old St. Augustine Road  
 Jacksonville, FL 32258  
 TEL: (904) 642-8990  
 FAX: (904) 644-4444  
 CA - 00002584 LC - 0000316

CORDOVA PALMS		
ALSOP COMPANIES, LLC		
ROAD NO.	COUNTY	ETH PROJECT NO.
SR 5 (US 1)	ST. JOHNS	17-355

SIGNATURE SHEET

SHEET NO.
2

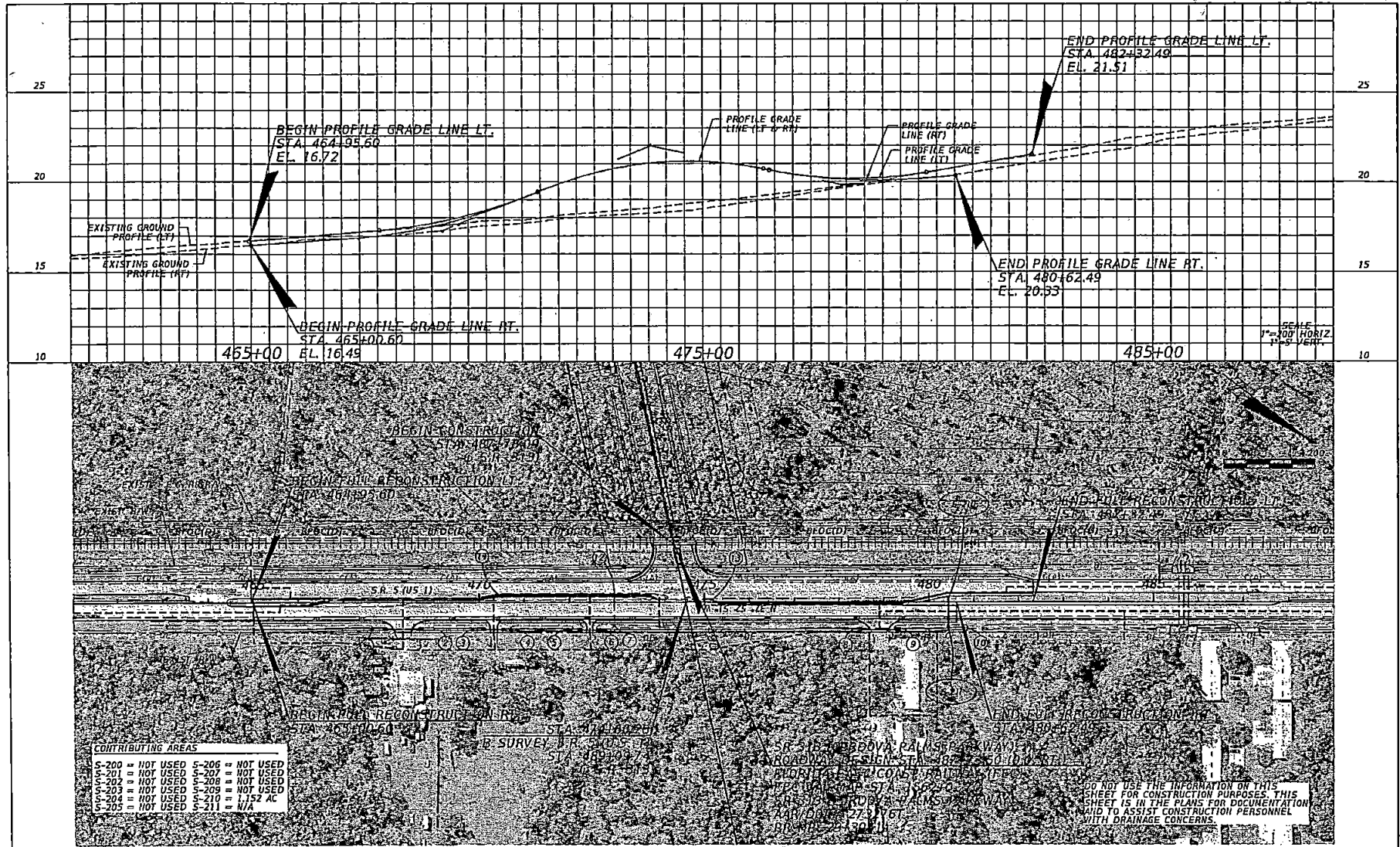

THE OFFICIAL RECORD OF THIS SHEET IS THE ELECTRONIC FILE DIGITALLY SIGNED AND SEALED UNDER RULE 61013-23.004, F.A.C.

REVISIONS		REVISIONS		ETM VINCE • ROY • BUCHHEIT • BOWEN	CORDOVA PALMS ALSOP COMPANIES, LLC			DRAINAGE MAP	SHEET NO. 3
DATE	DESCRIPTION	DATE	DESCRIPTION		ROAD NO.	COUNTY	ETM PROJECT NO.		
					SR 5 (US 1)	ST. JOHNS	17-355		

- ① 1 - MES  
1 - 24" RCP  
FL 13.03
- ② 1 - MES  
1 - 24" RCP  
FL 12.90
- ③ 1 - MES  
1 - 18" RCP  
FL 13.52
- ④ 1 - MES  
1 - 18" RCP  
FL 13.64
- ⑤ 1 - MES  
1 - 18" RCP  
FL 13.63
- ⑥ 1 - MES  
1 - 18" RCP  
FL 13.74
- ⑦ 1 - ENDWALL  
1 - 15" RCP  
FL 13.85
- ⑧ 1 - MES  
1 - 15" RCP  
FL 16.57
- ⑨ 1 - MES  
1 - 15" RCP  
FL 16.77
- ⑩ 1 - MES  
1 - 18" RCP  
FL 17.36
- ⑪ 1 - DITCH BOTTOM INLET  
1 - 18" RCP  
FL 14.31
- ⑫ 1 - DITCH BOTTOM INLET  
1 - 18" RCP NW FL 14.26  
1 - 15" RCP SE FL 14.26  
1 - 18" RCP NE FL 14.29
- ⑬ 1 - DITCH BOTTOM INLET  
1 - 18" RCP  
FL 14.33

THE OFFICIAL RECORD OF THIS SHEET IS THE ELECTRONIC FILE DIGITALLY SIGNED AND SEALED UNDER RULE 61G15-23.004, F.A.C.

REVISIONS		<b>ETM</b> <small>VERIFY • EXPLORE • RESULTS</small>	<b>CORDOVA PALMS</b>		<b>EXISTING DRAINAGE STRUCTURES</b>	SHEET NO.  4						
DATE	DESCRIPTION		DATE	DESCRIPTION								
				<table border="1" style="width: 100%; border-collapse: collapse;"> <tr> <td colspan="2" style="text-align: center;"><b>ALSOP COMPANIES, LLC</b></td> <td rowspan="2" style="text-align: center; vertical-align: middle;">ETM PROJECT NO.  17-355</td> </tr> <tr> <td style="text-align: center;">ROAD NO.</td> <td style="text-align: center;">COUNTY</td> </tr> <tr> <td style="text-align: center;">SR 5 (US 1)</td> <td style="text-align: center;">ST. JOHN</td> <td> </td> </tr> </table>	<b>ALSOP COMPANIES, LLC</b>		ETM PROJECT NO.  17-355	ROAD NO.	COUNTY	SR 5 (US 1)	ST. JOHN	
<b>ALSOP COMPANIES, LLC</b>		ETM PROJECT NO.  17-355										
ROAD NO.	COUNTY											
SR 5 (US 1)	ST. JOHN											

Engineers, Planners, & Surveyors  
Professional Association of Florida  
No. 3229  
P.O. Box 242,999  
Tallahassee, FL 32302  
CA: 00000000  
FL: 00000000  
PA: 00000000  
F.L. LICENSE NO. 17191

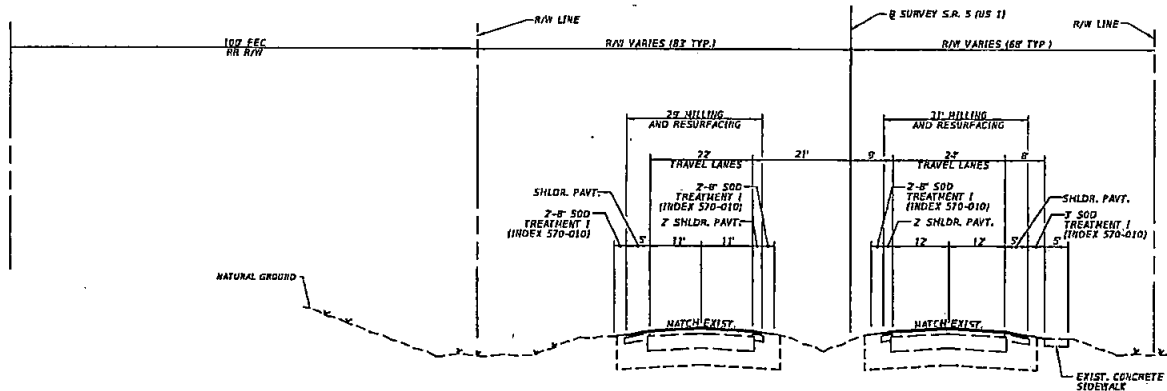

TYPICAL SECTION NO. 1  
 SR 5 (US 1)  
 STA. 452+38.32 TO STA. 464+95.60 (LT)  
 STA. 444+23.45 TO STA. 465+00.60 (RT)  
 STA. 480+62.49 TO STA. 492+19.90 (RT)  
 STA. 482+32.49 TO STA. 503+04.63 (LT)

**TRAVEL LANES AND SHOULDERS**  
 MILL EXISTING ASPHALT PAVEMENT FOR DEPTH (3/4")  
 FRICTION COURSE FC-5 (3/4") (TRAFFIC C) (PG 76-22)

**MEDIAN OPENINGS**  
**(FC-5 EXCLUSION - SEE PLANS FOR LIMITS)**  
 MILL EXISTING ASPHALT PAVEMENT FOR DEPTH (1 1/2")  
 FRICTION COURSE FC-12.5 (TRAFFIC C) (PG 76-22) (1 1/2")

**TRAFFIC DATA**  
 ESTIMATED CURRENT YEAR = 2019 AADT = 28600  
 ESTIMATED OPENING YEAR = 2020 AADT = 29800  
 ESTIMATED DESIGN YEAR = 2040 AADT = 55000  
 DESIGN SPEED = 65 MPH  
 POSTED SPEED = 60 MPH

REVISIONS		DESCRIPTION			CORDOVA PALMS			SHEET NO.
DATE	DESCRIPTION	DATE	DESCRIPTION		ALSO P COMPANIES, LLC			
				<small>           E. Thomas &amp; Associates, Inc.            5015 Old St. Augustine Road            Jacksonville, FL 32217            TEL: 904 242-2000            FAX: 904 242-2001            CA - LICENSE # 12,000,001            FL LICENSE # 12,000,001            P.E. LICENSE # 12,000,001         </small>	ROAD NO.	COUNTY	ETM PROJECT NO.	5
					SR 5 (US 1)	ST. JOHNS	17-355	

TYPICAL SECTIONS

THE OFFICIAL RECORD OF THIS SHEET IS THE ELECTRONIC FILE DIGITALLY SIGNED AND SEALED UNDER RULE 61G15-23.004, F.A.C.

THE OFFICIAL RECORD OF THIS SHEET IS THE ELECTRONIC FILE DIGITALLY SIGNED AND SEALED UNDER RULE 61C15-29.004, F.A.C.

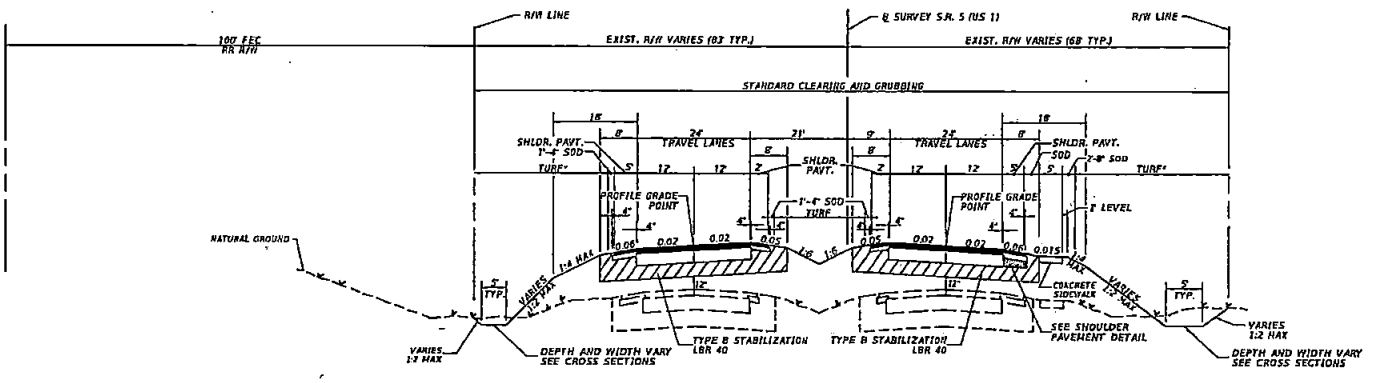

\*SOD SLOPES EQUAL TO OR STEEPER THAN 1:3. SOD ENTIRE FRONT SLOPE IF A PORTION OF FRONT SLOPE REQUIRES SOD, SEE TYPICAL SECTION DETAILS FOR DITCH PAVEMENT AND TURF REINFORCEMENT DETAILS.

TYPICAL SECTION NO. 2  
SR 5 (US 1)  
STA. 464+95.60 TO STA. 482+32.49 (LT)  
STA. 465+00.60 TO STA. 480+62.49 (RT)

TRAVEL LANES  
OPTIONAL BASE GROUP 9  
4 1/2" TYPE SP-12.5 STRUCTURAL COURSE (TRAFFIC C)  
3/4" FRICTION COURSE FC-5 (PG 76-22)

SHOULDER PAVEMENT  
OPTIONAL BASE GROUP 2  
3" TYPE SP-12.5 STRUCTURAL COURSE (TRAFFIC C)  
3/4" FRICTION COURSE FC-5 (PG 76-22)

ASPHALT DRIVEWAY  
OPTIONAL BASE GROUP 2  
3" TYPE SP-12.5 STRUCTURAL COURSE (TRAFFIC C)

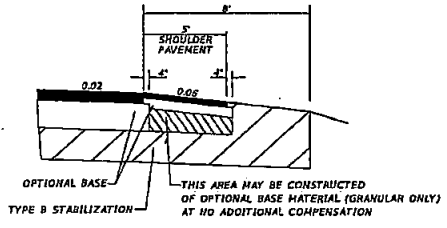

SHOULDER PAVEMENT DETAIL  
OUTSIDE SHOULDER SHOWN; INSIDE SHOULDER SIMILAR

TRAFFIC DATA  
ESTIMATED CURRENT YEAR = 2019 AADT = 28500  
ESTIMATED OPENING YEAR = 2020 AADT = 28800  
ESTIMATED DESIGN YEAR = 2040 AADT = 33600  
DESIGN SPEED = 65 MPH  
POSTED SPEED = 60 MPH

REVISIONS		DESCRIPTION			CORDOVA PALMS		TYPICAL SECTIONS	SHEET NO. 6
DATE	DESCRIPTION	DATE	DESCRIPTION		ROAD NO.	COUNTY		
					SR 5 (US 1)	ST. JOHNS		



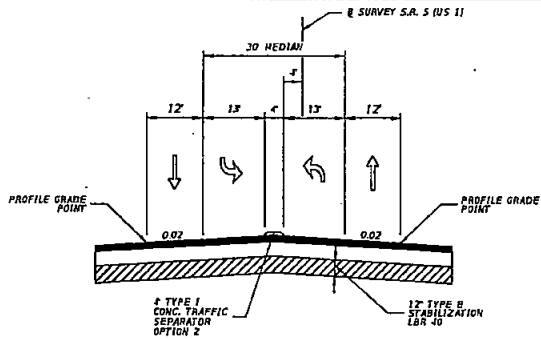

**BACK-TO-BACK LEFT TURN LANES**  
SR 5 (US 1)

STA. 466+70.60 TO STA. 470+43.16

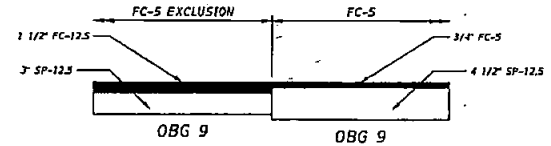

**FC-5 EXCLUSION - FULL DEPTH PAVEMENT DETAIL**  
SEE PLANS FOR LIMITS

**TRAVEL LANES AND MEDIAN OPENINGS**  
OPTIONAL BASE GROUP 9  
3" TYPE SP-12.5 STRUCTURAL COURSE (TRAFFIC C)  
1 1/2" FRICTION COURSE FC-12.5 (TRAFFIC C) (PG 76-22)

**SHOULDER PAVEMENT**  
OPTIONAL BASE GROUP 2  
1 1/2" TYPE SP-12.5 STRUCTURAL COURSE (TRAFFIC C)  
1 1/2" FRICTION COURSE FC-12.5 (TRAFFIC C) (PG 76-22)

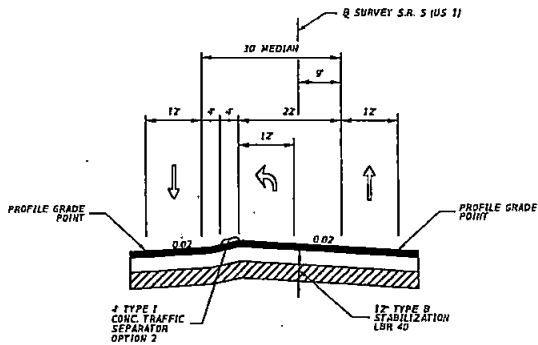

**OFFSET LEFT TURN LANE**  
SR 5 (US 1)

STA. 470+43.16 TO STA. 473+81.01  
STA. 475+32.49 TO STA. 479+42.49

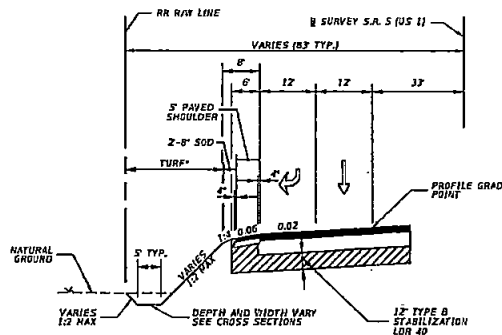

**RIGHT TURN LANE**  
SR 5 (US 1)

STA. 475+37.37 LT. TO STA. 482+32.49 LT.

\*SOD SLOPES EQUAL TO OR STEEPER THAN 1:3. SOD ENTIRE FRONT SLOPE IF A PORTION OF FRONT SLOPE REQUIRES SOD.

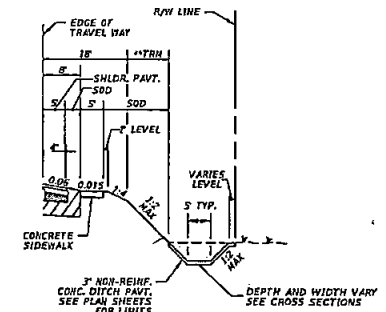

**DITCH PAVEMENT AND TURF REINFORCEMENT DETAIL**

\*\*TRN - TURF REINFORCEMENT MAT, PLASTIC EROSION MAT, TYPE 3 FROM STA. 470+40 TO STA. 477+00 RT

REVISIONS	
DATE	DESCRIPTION



ETM  
1175 Old St. Augustine Rd  
Jacksonville, FL 32218  
TEL: 904 444-4444  
FAX: 904 444-4444  
CORPORATE OFFICE  
10000 W. BAYVIEW BLVD., SUITE 1000  
MIAMI, FL 33156

CORDOVA PALMS		
ALSOP COMPANIES, LLC		
ROAD NO.	COUNTY	ETM PROJECT NO.
SR 5 (US 1)	ST. JOHNS	17-355

TYPICAL SECTION DETAIL	
DATE	SHEET NO.
	7

THE OFFICIAL RECORD OF THIS SHEET IS THE ELECTRONIC FILE DIGITALLY STORED AND SEALED UNDER RULE 61015-23.004, F.A.C.

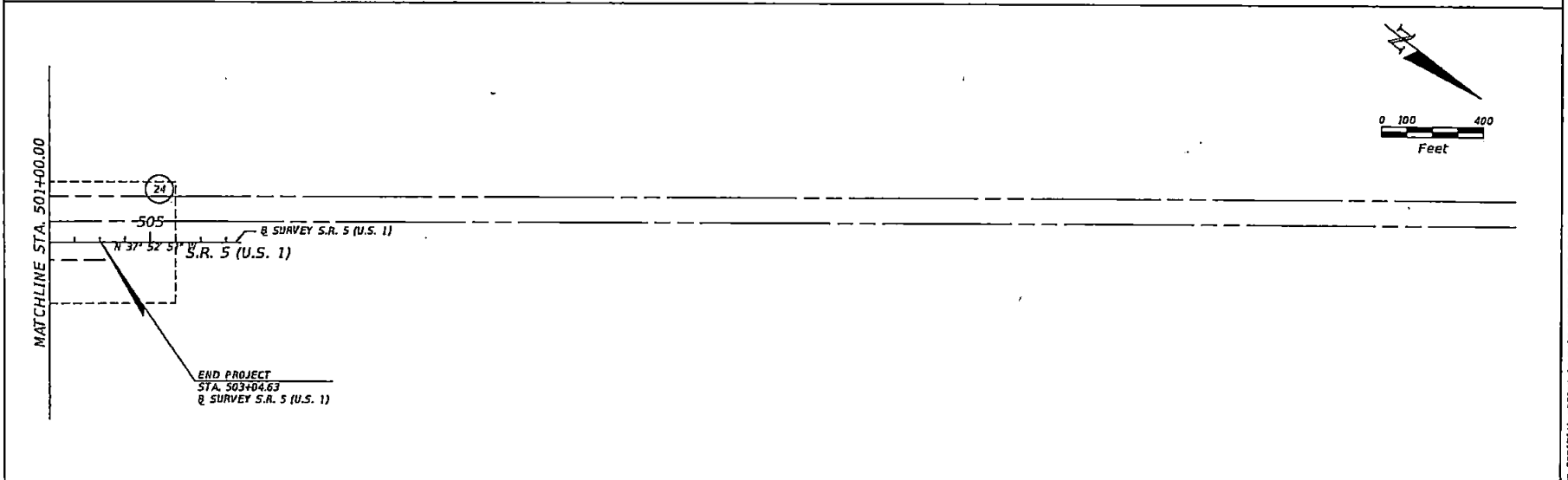
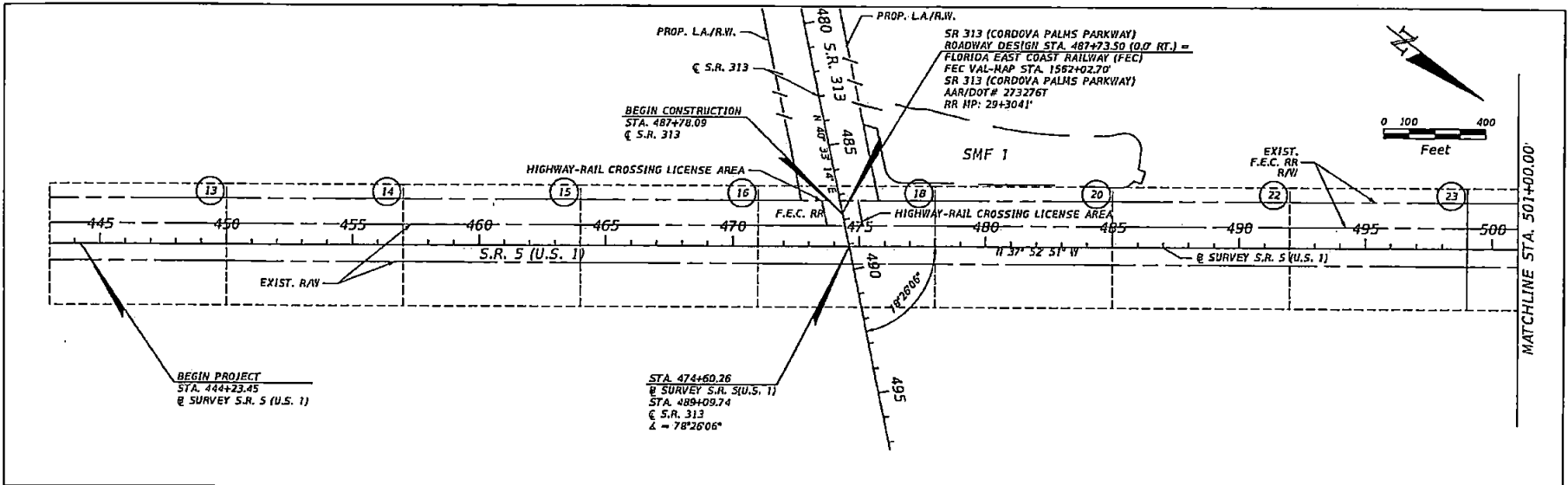

REVISIONS		DESCRIPTION	
DATE	DESCRIPTION	DATE	DESCRIPTION

ETM  
Engineering & Technical  
Services, Inc.  
11000 N. US Highway 1  
Tampa, FL 33613  
TEL: 813-942-1010  
FAX: 813-942-1011  
E-MAIL: info@etm.com  
www.etm.com

**CORDOVA PALMS**  
**ALSOP COMPANIES, LLC**

ROAD NO.	COUNTY	ETM PROJECT NO.
SR 5 (US 1)	ST. JOHNS	17-355

PROJECT LAYOUT

SHEET  
NO.  
8

THE OFFICIAL RECORD OF THIS SHEET IS THE ELECTRONIC FILE DIGITALLY STORED AND SEALED UNDER RULE 61G15-23.004, F.A.C.