

**RESOLUTION NUMBER 2022-263**

**RESOLUTION OF THE BOARD OF THE COUNTY OF ST. JOHNS, STATE OF FLORIDA AMENDING A JOINT UNIFIED SIGN PLAN TO THE FOUNTAINS NORTH PUD; ORDINANCE NO. 2021-58, AS AMENDED, THE FOUNTAINS SOUTH PUD; ORDINANCE 2021-59, AS AMENDED, THE FOUNTAINS EAST PUD; ORDINANCE 2020-59, THE TRACTOR SUPPLY PUD; ORDINANCE 2021-60, AS AMENDED.**

**NOW, THEREFORE, BE IT RESOLVED BY THE BOARD OF COUNTY COMMISSIONERS OF ST. JOHNS COUNTY, FLORIDA:**

**SECTION 1.** Pursuant to the request by Prosser, Inc., on behalf of St. Vincent's Health System, Inc., the Fountains East Investment One, LLC, DAR Investments One, LLC, and Hanlex Saint Augustine, LLC, the current owners of the properties, Ordinance 2021-58, as amended, Ordinance 2020-59, as amended, Ordinance 2021-59, as amended and Ordinance 2021-60 is hereby modified as set forth in application File Number USP 2022-01, as more generally described below:

To allow for a Sign Plan to guide construction of new signs within the developments of Fountains North Ordinance 2021-58, as amended, Fountains South Ordinance 2021-59, as amended, Fountains East 2020-59, and Tractor Supply Ordinance 2021-60, as amended, pursuant to LDC Article VII.

**SECTION 2. Findings of Fact:**

Having considered the application, along with supporting documents; the Staff report prepared on July 19<sup>th</sup>, 2022, statements by the applicant; and all evidence presented during public hearing, the Agency finds as follows:

1. The request for Joint Unified Sign Plan approval has been fully considered after public hearing with legal notice duly published as required by law.
2. Joint Unified Sign Plan is consistent with and furthers the objectives of the 2025 St. Johns County Comprehensive Plan.
3. The review process and the application are consistent with the applicable requirements of the St. Johns County Land Development Code.
4. The Comprehensive Signage Plan is consistent with the Fountains North PUD Ordinance 2021-58, as amended, Fountains South PUD Ordinance 2021-59, as amended, Fountains East Ordinance 2020-59, and Tractor Supply Ordinance 2021-60, as amended.

**SECTION 3.** This Resolution shall take effect upon its adoption.

**PASSED AND ADOPTED BY THE BOARD OF COUNTY COMMISSIONERS OF ST. JOHNS COUNTY, FLORIDA, THIS 19<sup>th</sup> DAY OF JULY, 2022.**

**BOARD OF COUNTY COMMISSIONERS  
OF ST. JOHNS COUNTY, FLORIDA**

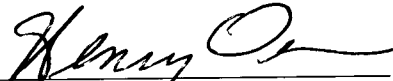
BY:   
Henry Dean, Chair

ATTEST: Brandon J. Patty, Clerk of the Circuit Court & Comptroller

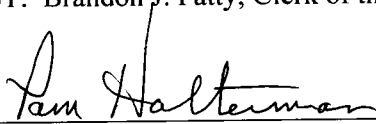
By:   
Deputy Clerk

Rendition Date 7/21/22

EFFECTIVE DATE: July 19, 2022



# JOINT UNIFIED SIGN PLAN

for

**Fountains South PUD  
FKA St. Johns Commons at CR 210**

**PUD PRE WAT 2016-58 (R-98-025)**

**Fountains North at St. Johns PUD**

**PUD 2019-13**

**Tractor Supply PUD**

**PUD 2018000009**

**Fountains East PUD**

**PUD 2020000009**

21 September 2021  
Revised 6 May 2022

| <b>CONTENTS</b>   | <b>PAGE</b> |
|---|-------------|
| <b>A. Introduction</b>  | <b>1</b>    |
| <b>B. General Standards</b>                                   | <b>1</b>    |
| <b>C. Permissible Signs</b>                                   | <b>2</b>    |
| <b>D. Locations</b>   | <b>4</b>    |
| <b>E. Placement</b>   | <b>5</b>    |
| <b>D-1. JUSP Location Map</b>                                 | <b>6</b>    |
| <b>D-2. JUSP Location Map (Fountains East)</b>                | <b>7</b>    |
| <b>F. Lettering</b>   | <b>8</b>    |
| <b>G. Public Art</b>  | <b>8</b>    |
| <b>H. Signs Within Rights-of-Way</b>                          | <b>8</b>    |
| <b>I. Sign Construction</b>                                   | <b>8</b>    |
| <b>J. Special Event and Temporary Signs</b>                   | <b>9</b>    |
| <b>K. Other Features</b>                                      | <b>9</b>    |
| <b>L. Prohibited Signs</b>                                    | <b>10</b>   |
| <b>M. Waivers</b>   | <b>11</b>   |
| <b>Appendix 1 – Conceptual Graphics</b>                       |             |
| <b>Appendix 2 – Tenant Signage Criteria (Fountains South)</b> |             |

## A. Introduction

As part of the Master Development Plans for four contiguous Planned Unit Developments, this comprehensive plan for signage has been prepared to assure the design and placement of signs will be carefully considered so that each sign design harmonizes with the others that have relevant association.

The Joint Unified Sign Plan (“**JUSP**”) is a conceptual document that provides a signage program for the public open spaces and general recommendations for the design, scale, location and content of signage within the developed areas. This JUSP provides flexibility for signage to reflect the diverse nature of the non-residential uses. Thus, the graphics contained herein are for illustrative purposes only and are not intended to be actual depictions of sign design. This document includes criteria for project identification, specialty icons/signs, parcel identification, and wayfinding signs. The successful implementation of this JUSP will enable visitors and tenants alike to identify the hospital, medical park, professional offices, commercial retail and service uses, entertainment venues, and conservation lands.

## B. General Standards

For purposes of this JUSP, any sign located within the boundaries of the Fountains South (fka St. Johns Commons at CR 210) PUD, Fountains North at St. Johns PUD, Fountains East PUD, and Tractor Supply PUD (collectively “**Subject Property**”) will be considered an “on-premise sign”, without regard to ownership of individual parcels so long as the sign content is relevant only to development within the Subject Property. Unless otherwise stated herein, signs will conform to requirements of the St. Johns County Land Development Code (“**LDC**”).

A coordinated theme will be established for the signage that will provide a logical hierarchy to be used throughout the Subject Property. No signage shall be allowed to describe development outside of the Subject Property’s boundaries; provided, however, the JUSP shall be applicable to any properties that may be added to any of the four PUDs in the future. This JUSP can only apply to property added to the PUDs after approval of a change to the approved PUD pursuant to LDC Sec. 5.03.05.

The following signage standards apply to all signage located within the Subject Property:

1. Signs may be single-sided or multi-sided. The maximum Advertisement Display Area (ADA) for multi-sided signs pertains to each sign face calculated separately, not cumulatively, for each sign face.
2. All signage setbacks are measured from the property line to the base of the sign at the interface with the ground plane.
3. All signs greater than eight (8) feet in height and greater than twenty-four (24) square feet of ADA may be illuminated using internal lights, external lights, halo lit letters, shielded/niche down and/or up-lighting.
4. The ends of multi-tenant buildings (sides other than fronts and rears of such buildings) are known as “end caps”. End cap units will be permitted to have front facades and side facades, with signage for each façade based on requirements set forth in this JUSP.
5. All lighting standards of LDC Sections 6.09.02 and 7.00.06.C shall be adhered to by all lighted sign locations.
6. Gas Station Identity Monuments are permitted for each outparcel on which a gas station is located. This sign type may include electronic message boards for numbers.

The Appendix includes depictions of sign materials, colors and shapes that are conceptual illustrations of the general character of signage to be located within the Subject Property. These concepts are subject to change and modification including, but not limited to, changes in shape, layout, and location of ADA.

### C. Permissible Signs

Table 1 identifies the JUSP’s permissible *freestanding* sign types, the maximum numbers of each sign type allowed, locations, as well as maximum height and ADA of each sign. The Map ID for certain signs corresponds to their respective symbols on the **JUSP Location Map (Exhibits “D-1” and “D-2”)**. Table 2 identifies the JUSP’s permissible *building/wall* signs, the maximum numbers allowed, and maximum height and ADA of each sign. Definitions of each permissible freestanding sign type follow Table 1.

In addition to the signs prescribed in Tables 1 and 2, the two (2) existing billboards located on-site may remain in use in accordance with the LDC.

The reference to ADA in Table 1 is defined by a discernable geometric shape that may be used to encompass all advertising lettering. In calculating the ADA, the area shall be broken down into simple common forms for which a mathematical formula can be applied.

| Table 1<br>Permissible Freestanding Signs                                |  |                          |                        |                       |                                      |
|--|--|--------------------------|------------------------|-----------------------|--------------------------------------|
| Map ID   | Location within Subject Property   | Max. Number              | Max. ADA per side (SF) | Max. Sign Height (FT) | Max. Height of Architectural Feature |
| <b>Type A: Commercial Identity Pylon</b>                                 |  |                          |                        |                       |                                      |
| A.1  | Along Interstate 95 frontage within Fountains North at St. Johns PUD (single-tenant or multi-tenant) | 3                        | 500                    | 120                   | 150                                  |
| A.2  | Interstate Pole Sign (single-tenant) – Tractor Supply PUD  | 1 per outparcel          | 250                    | 120                   | 120                                  |
| A.3  | Along Interstate 95 frontage within Fountains South PUD - Pole Sign (multi-tenant)                   | 1                        | 300                    | 120                   | 120                                  |
| <b>Type B: Project Identity Monument</b>                                 |  |                          |                        |                       |                                      |
| B.1  | Primary Project Identification Sign (multi-tenant)   | 5                        | 160                    | 35                    | 35                                   |
| B.2  | Monument or Pole Sign Tractor Supply PUD (single-tenant)   | 1 per building           | 150                    | 20                    | 20                                   |
| B.3  | Project Identification Sign within Fountains South PUD (multi-tenant)                                | 2                        | 100                    | 15                    | 15                                   |
| B.3  | Project Identification Sign within Fountains East PUD (multi-tenant)                                 | 1                        | 100                    | 15                    | 15                                   |
| B.4  | Project Identity at Fountain within Fountains South PUD  | 1                        | 50                     | 15                    | 15                                   |
| B.5  | Project Identity at Entry within Fountains South PUD   | 1                        | 250                    | 15                    | 15                                   |
| B.6  | Project Identity at Entry within Fountains South PUD (at Fountains Way)                              | 1                        | 290                    | 35                    | 35                                   |
| <b>Type C: Business Identity Monument</b>                                |  |                          |                        |                       |                                      |
| C.1  | Medical Multi-Tenant Sign  | 1 per building           | 150                    | 35                    | 35                                   |
| C.2  | Multi-Tenant Sign or Single-Tenant Sign  | 1 per building           | 150                    | 15                    | 15                                   |
| C.3  | Outparcels along CR 210 within Fountains South PUD   | 1 per outparcel (5 max.) | 150                    | 15                    | 15                                   |
| C.4  | Outparcels along CR 210 frontage within Tractor Supply PUD   | 1 per outparcel (3 max.) | 150                    | 15                    | 15                                   |
| <b>Type D: Medical Campus Monument</b>                                   |  |                          |                        |                       |                                      |
| D.1  | Hospital Icon  | 4                        | 190                    | 20                    | 40                                   |
| D.2  | Medical Campus Identification  | 2 per building           | 100                    | 10                    | 16                                   |
| <b>Type E: Directional Wayfinding (applies collectively to all PUDs)</b> |  |                          |                        |                       |                                      |
|  | Internal road intersections  | 15                       | 60                     | 15                    | 20                                   |
|  | Along interior roadways  | N/A                      | 52                     | 10                    | 12                                   |
|  | Along interior sidewalks   | N/A                      | 40                     | 10                    | 10                                   |
| <b>Type F: Pedestrian Wayfinding (applies collectively to all PUDs)</b>  |  |                          |                        |                       |                                      |
|  | Along interior sidewalks   | N/A                      | 12                     | 6                     | 8                                    |

**Type A, Commercial Identity Pylons** are mostly located adjacent to Interstate 95 and County Road 210. These signs shall be designed to complement the architecture within the PUDs. Each Commercial Identity Pylon is permitted to display the name, logo and/or symbol of the primary business or organizations located within the PUDs. Additionally, the Commercial Identity Pylons noted in Table 1 as multi-tenant may include additional representation of business lines and/or tenants. Commercial Identity Pylons may be single or multi-tenant (as noted in Table 1). Lighting shall be per the General Standards Section B, 3. Commercial Identity Pylons must be no closer than 100 feet from one another.

**Type B, Project Identity Monuments** are gateway features located at the primary entrances from County Road 210. Each will function as entry features/monuments comprised of single element or up to three elements (Type B signs are the only signs that may contain up to three elements). The general orientation of the signs and quantity of elements are indicated on Exhibit "D-1". For Type B signs, each element is permitted to include the height and ADA standards indicated in Table 1. These monuments may be single, multi-tenant or display multiple business lines of the same entity as referenced in Table 1. Lighting shall be per the General Standards Section B, 3.

**Type C, Business Identity Monuments** display the individual tenant name or multiple tenant names located on an individual development parcel and/or any tenants located within that particular PUD. Lighting shall be per the General Standards Section B, 3. The business and/or organization name shall be the dominant message (larger sign) with the option of including the project name and/or logo as a subordinate message (smaller sign) while remaining within the maximum permissible ADA limits.

Where C.1 or C.2 Map Identifications are referenced on the JUSP map, the following shall apply: In conditions when the parcel remains within the ownership of St. Vincent's Health System, Inc., Ascension or its affiliates the criteria associated with C.1 shall apply. For all other ownership conditions C.2 shall apply.

**Type D, Medical Campus Monuments** display singularly or in combination on a single element the following: hospital logo, hospital name and/or logo, professional group name and/or logo, and/or tenant name and/or logo while remaining within the maximum permissible ADA limits.

Hospital Icons are associated with identifying the hospital and/or its uses. Medical Campus Identification signs may include reference to the hospital but focus on providing information related to ancillary uses or synergistic tenants on the campus.

**Type E, Directional Wayfinding Signs** indicate to travelers, bicyclists and pedestrians the locations of buildings, offices, tenants and drive-thru locations, common areas, medical facilities, retail stores, and access points. Each sign may be single or double-sided and bear information related to the uses and tenants within the four PUDs and shall be permitted within the right-of-way. The design of these signs should reflect the character of the nearby buildings.

For pedestrian Directional Wayfinding signs, such as "informational sidewalk kiosks", 1, 2, 3, or 4 sides (or cylindrical), such signs shall be consistent with the signage articulated in Table 1 as "Along Interior Sidewalks". All Vehicular Control Signs shall meet the requirements of the Manual on Uniform Traffic Control Devices and may include decorative post(s), sign backing and finials.

**Type F, Pedestrian Wayfinding Signs** provide patrons with directional information regarding uses and tenants. Each sign may be single or double-sided and bear information related to the uses and tenants within the four PUDs and shall be permitted within the right-of-way.

| Table 2<br>Permissible Wall Signs |  |  |  |
|-----------------------------------|--|--|--|
| Wall Sign Type                    | General Location   | Max. Quantity  | Max. Area (SF)   |
| Hospital Name                     | Hospital building(s)   | 1 per vertical building face   | 500  |
| Hospital Logo                     | Hospital building  | 5  | 400  |
| Hospital Cross Symbols            | Hospital building(s)   | N/A  | 190  |
| Hospital Entrance Identifier      | Hospital building or canopies  | 1 per side or canopy   | 120  |
| Medical Campus - Primary          | Freestanding medical buildings   | 2 per tenant   | 1.5 SF per linear foot of occupancy frontage, not to exceed 150 SF per sign        |
| Medical Campus - Secondary        | Freestanding medical buildings   | 1 per tenant   | 65% of Primary signage   |
| Junior Tenant (1)                 | Retailers with up to 45,000 SF of leasable area each, grouped in-line in large, multi-tenant buildings | 2 per tenant   | 1.5 SF per linear foot of occupancy frontage, not to exceed 150 SF                 |
| Anchor Tenant (1)                 | Large retailers in freestanding buildings more than 45,000 SF of leasable space                        | 2 per tenant   | 1.5 SF per linear foot of occupancy frontage, not to exceed 200 SF                 |
| Outparcel                         | Front Façade (1)   | Freestanding, primarily single tenant buildings; includes convenience stores | 1 per tenant<br>1.5 SF per linear foot of occupancy frontage, not to exceed 150 SF |
|                                   | Rear Façade (1)  | Freestanding, primarily single tenant buildings; includes convenience stores | 1 per tenant<br>Not to exceed 75% Front Façade signage dimensions                  |
|                                   | End Caps (1)   | Freestanding, primarily single tenant buildings; includes convenience stores | 1 per tenant<br>Not to exceed 65% of Front Façade signage dimensions               |
| Gasoline Station Canopy           | Gas stations, convenience stores w/gas   | Each side of the canopy over gas pump area – Maximum 3 canopy signs per site | 1.5 SF per linear foot of applicable canopy, not to exceed 48 SF                   |

(1) Wall signs within Fountains South PUD are subject to criteria specified in Appendix 2.

### D. Locations

The general locations of larger pylons and monument (ground) signs are shown on **Exhibit “D-1”, the JUSP Location Map and Exhibit “D-2”, the JUSP Location Map-Fountains East** (see pages 6 and 7, respectively). Sign locations depicted on the Map are approximate and actual locations may vary according to unforeseen field conditions or to prevent conflict with existing or planned utilities. This Map may be updated periodically subject to County approval of a Small Adjustment to the PUD that reflects any changes to sign types and/or locations.

In the event sign locations on the Map conflict with existing utilities, the utility contractor will not be responsible for damage or repair to existing signs. Utility sleeves will be installed as necessary under monument (ground) signs to accommodate future utility changes.

Smaller monument (ground) signs, directional signs, and tenant types for wall sign purposes are not depicted on **Exhibits “D-1” and “D-2”** but shall be detailed on future Incremental Master Development Plans to allow for County review of such signs in relation to this JUSP.

### E. Placement

Signs may be pylons, monument (ground) signs, or may be incorporated into a wall, architectural feature, building or other structure and may include decorative aspects such as architectural features, waterfalls, columns, etc. consistent with the overall theme of the development. The sign body may be of any material having structural qualities in accordance with the most current Florida Building Code wind load requirements. The body of monument (ground) signs may be of cast concrete or epoxy/aggregate materials, concrete, brick, stone, marble, wood, metal or composite materials. Surface finishes may be stucco or stucco-like, paint, enamel or other finishes that may protect and enhance the sign structure materials. Decorative accents may include glass, tile, metal, terra cotta or other material. The structure may have any combination of materials and finishes.

An architectural feature may incorporate project signage features. Architectural features include, but not be limited to, columns, clocks, towers, waterfalls, flanking walls, landscaped areas, and shelters. For the purposes of regulation, the Maximum Sign Height shall be deemed to be the height of the Advertising Display Area (ADA). The height of the sign shall not include associated architectural features or signage structures. The height of the sign shall be measured from finished grade to the top of the ADA.

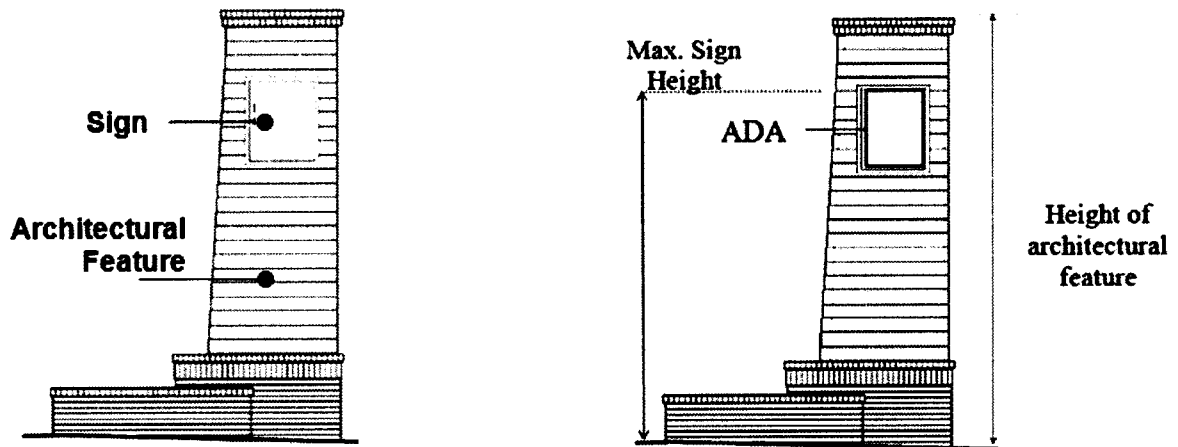



# Exhibit "D-1" JUSP Location Map

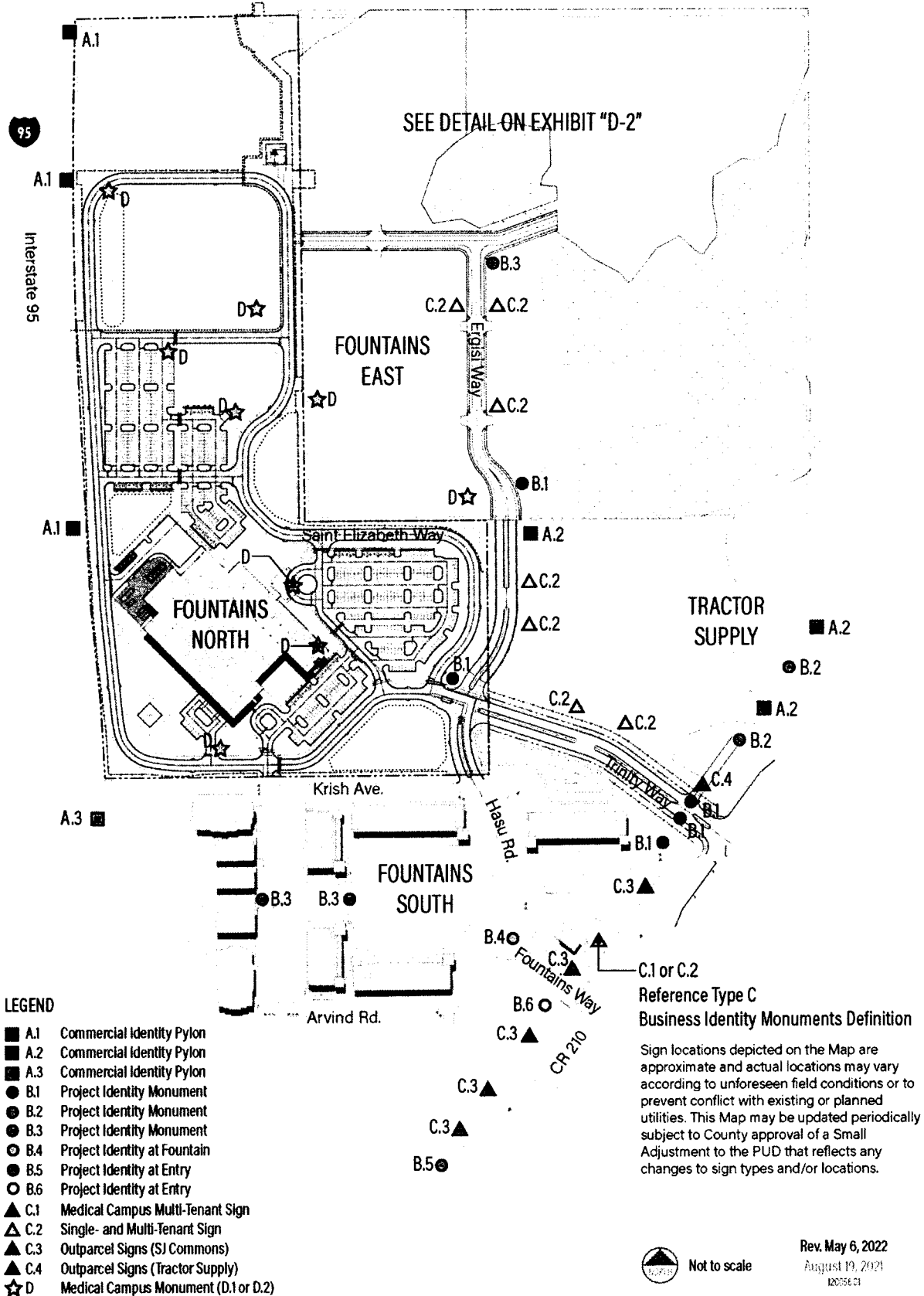

## Exhibit "D-2" JUSP Location Map – Fountains East

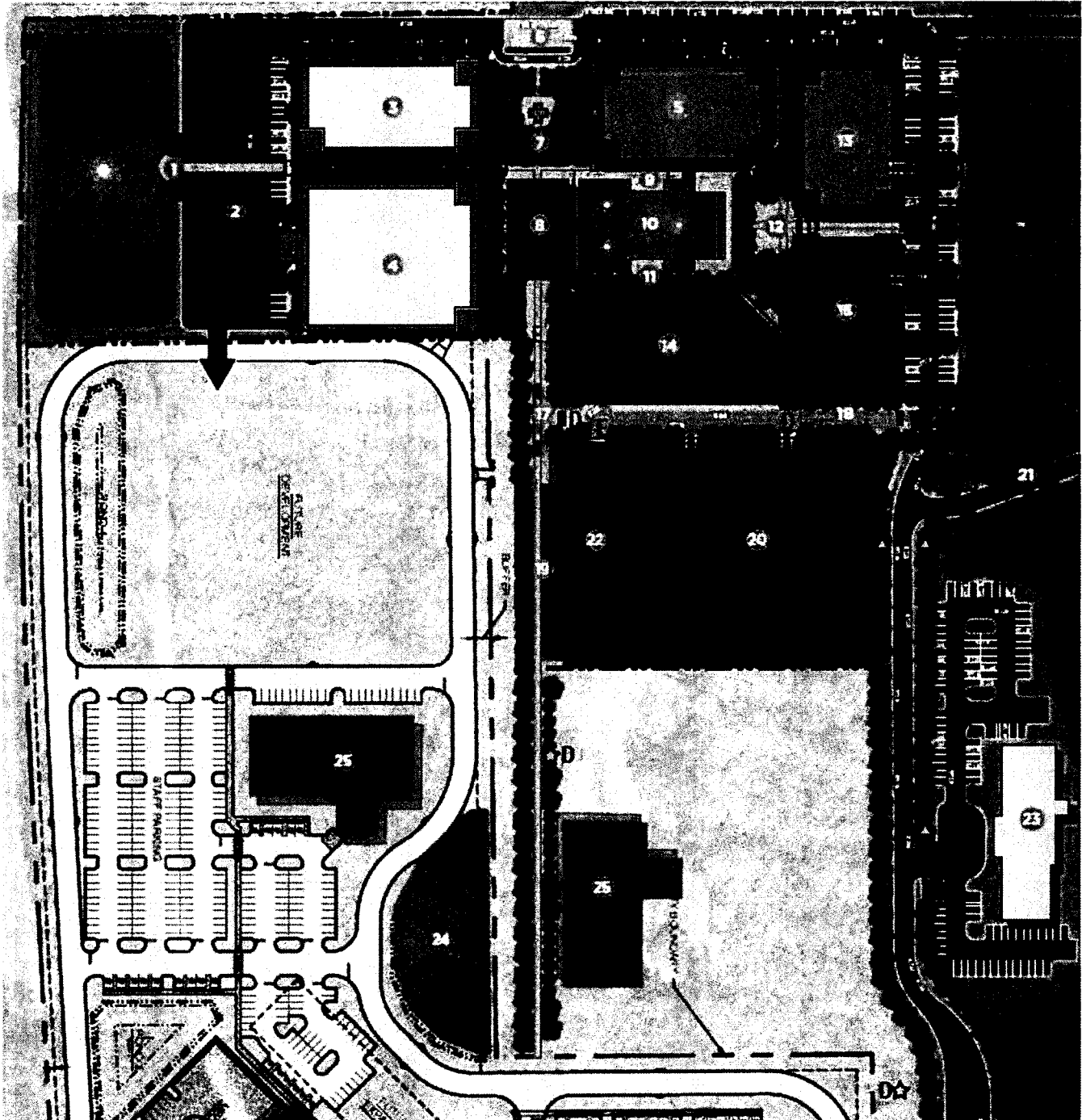

**LEGEND**

- |                                    |  |
|------------------------------------|--|
| ■ A.1 Commercial Identity Pylon    | ▲ C.1 Medical Campus Multi-Tenant Sign   |
| ■ A.2 Commercial Identity Pylon    | △ C.2 Multi-Tenant Sign                  |
| ■ A.3 Commercial Identity Pylon    | ▲ C.3 Outparcel Signs (SJ Commons)       |
| ● B.1 Project Identity Monument    | ▲ C.4 Outparcel Signs (Tractor Supply)   |
| ● B.2 Project Identity Monument    | ☆ D Medical Campus Monument (D.1 or D.2) |
| ● B.3 Primary Identity Monument    | ■ E Directional Wayfinding               |
| ● B.4 Project Identity at Fountain | ■ G Pedestrian Gateway                   |
| ● B.5 Project Identity at Entrance | —H Tenant Building Sign                  |

Sign locations depicted on the Map are approximate and actual locations may vary according to unforeseen field conditions or to prevent conflict with existing or planned utilities. This Map may be updated periodically subject to County approval of a Small Adjustment to the PUD that reflects any changes to sign types and/or locations.



## F. Lettering

All lettering shall be attached to the building surface. There shall be no backing, plates, screens, sheets or boards behind lettering. Lettering may be:

- Mounted on inserts or panels to be attached to a sign structure or building face,
- Pin mounted or surface mounted lettering,
- Sand blasted or otherwise engraved into a surface, acrylic, or may be painted or otherwise affixed to the sign structure or background.

Lettering may be glass, metal, wood, PVC or other plastic-like or composite material. If sand blasted or otherwise engraved, the ADA may be the same material as the sign structure or may be of a complementary material. Lettering may have any combination of materials and style and may be affixed to the sign structure in a combination of the aforementioned.

## G. Public Art

Building murals and sculpture pieces are allowable and are not considered signs. Such murals and sculpture are considered public art and will not require sign permitting through the St. Johns County Development Services Division. Traffic control signage may have aesthetic enhancement as may be acceptable to the Florida Department of Transportation (FDOT) and St. Johns County and may be installed by the Owner within roadways throughout the Subject Property.

## H. Signs Within Rights-of-Way

In addition to the signage specifically defined in the LDC, some signs may be located within the right-of-way due to their size and function, but only within areas for which the County has approved a right-of-way use and maintenance agreement.

Street, traffic and directional signs shall be of the size and style of standard signage utilized throughout St. Johns County. The exact sign design will be developed at a later date. They will be of aluminum posts, caps and frames with concrete footings. The sign faces shall be stainless steel signs with colored, reflective coatings according to state and county law.

While signs will be permissible within the right-of-way based on the Owner entering into a maintenance agreement with the County placing responsibility for the signs with the Owner including its successor and assigns, no sign shall be erected that will interfere with clear and free visibility from any roadway intersection or other public right-of-way or that will be confused in shape, color or pattern with any authorized traffic sign, signal or device.

Any signage located within the right-of-way and subject to an aforementioned use and maintenance agreement shall be maintained by the Owner, a Property Owner's Association ("POA"), or a Community Development District ("CDD"), as applicable. The Owner, POA and/or CDD shall be responsible for any signage and associated landscaping, lighting and/or decorative hardscape elements that may be located within public rights-of-way, subject to the Owner, POA and/or CDD entering into a hold harmless agreement with St. Johns County in a form reasonably acceptable to both parties.

## I. Sign Construction

1. All electrical signs will be fabricated by an Underwriters Laboratories (U.L.) approved sign company, according to U.L. specifications and bear a U.L. label.
2. Sign companies installing such signs must be fully licensed with the County and State and shall provide proof of full Workman's Compensation and general liability insurance.
3. All penetrations of building exterior surfaces are to be sealed, waterproofed and in color and finish to match existing exterior.

4. Internal illumination to be 30 milliamp neon, fluorescent tube or LED of storefront elevations and #3500 white neon or LED halo for freeway elevations. Installed and labeled in accordance with the "National Board of Fire Underwriters Specifications".
5. Painted surfaces must have an acrylic polyurethane finish or baked-on finish.
6. All sign fabrication work shall be of excellent quality. All logo images and type styles shall be accurately reproduced.
7. All lighting must match the exact specification of the approved working drawings. No exposed conduits or race ways will be allowed.
8. Signs must be made of durable, rust-inhibited materials that are appropriate and complimentary to the building.
9. Joining materials (e.g., seams) shall be finished in such a way as to be unnoticeable. Visible welds shall be continuous and ground smooth. Rivets, screws and other fasteners that extend to visible surfaces shall be flush, filled and finished so as to be unnoticeable.
10. Finished surfaces of metal shall be free from canning and warping. All sign finishes shall be free from dust, orange peel, drips, and runs and shall have a uniform surface conforming to the highest standards of the industry.
11. In no case shall any manufacturer's label be visible from the street from normal viewing angles.
12. Exposed junction boxes, lamps, tubing or neon crossovers of any type are not permitted.

## J. Special Event and Temporary Signs

Special event signs will be allowed and installed in accordance with LDC Sections 7.05.00 and 7.02.03. Temporary signage shall be allowed within the Subject Property in accordance with the requirements of the LDC. Project construction signs will be considered temporary signs and installed in accordance with LDC Sections 7.02.02 and 7.02.03.

Construction Signs – Each PUD will be allowed up to two (2) construction signs depicting project data, graphics, and/or project team information. The construction sign may be single or multi-sided, fifteen feet (15') maximum height and 64 square feet of ADA on each side.

## K. Other Features

**Flags.** Up to three permanent flags may be flown per business site and office site, as specified in LDC Section 7.02.06. For purposes of this JUSP, a business or office site shall be defined as a unit of property that is owned, leased or rented and serves as an occupied place of business within the PUD. Flagpole heights shall not exceed thirty (30) feet. Temporary flags will comply with the requirements of LDC Section 7.02.02 and 7.02.03.

**Awning Signs.** For the purpose of awning signage, the anchor/tenant buildings shall be deemed as one (1) single enclosed building such that the awning signage facing the pedestrian and vehicular drives within the interior of the PUDs are deemed as interior signs. Additionally, wall signage facing public rights-of-way for each tenant within the anchor/tenant buildings will be permitted and will not exceed ten (10) percent of the square footage of the occupancy frontage or respective sides of the building facing public rights-of-way. These signs may be perpendicular to the street and may encroach into the right-of-way and/or setbacks. These signs will maintain a minimum clearance distance of at least ten (10) feet over pedestrian use areas and 18 feet over vehicle use areas. Awning sign ADA will be deducted from overall wall signage for each building.

**Under the Canopy Signs.** One (1) under the canopy sign per occupancy is permitted not exceeding a maximum of eight (8) square feet in ADA per side; provided, any square footage utilized for an under the canopy sign shall be subtracted from the allowable square footage that can be utilized for wall signs. These signs may be perpendicular to the street and may encroach into the right-of-way and/or setbacks. These signs will maintain a minimum clearance distance of at least ten (10) feet over pedestrian use areas and 18 feet over vehicle use areas.

**Banner Signs.** Banner signs will be permitted for temporary and special events. Such signs shall not exceed 120 square feet in ADA. Banner signs will be permitted in the entrances and interior of the PUDs. The banners shall

be allowed to display logos and/or the name of the Project and/or Owner. Banners placed on streetlight poles are permitted and unregulated. Banner signs do not count toward the overall maximum ADA allowable for monument and pylon signs. Banners shall be maintained by the Owner, POA or CDD to limit interference with public utilities, pedestrian and vehicle access and visibility.

**Window Signs.** Signs located on the interior of a structure, but visible from the exterior of the building, are permitted and are not part of the maximum allowed sign area. Such signs are not physically attached or painted to the window and do not obscure more than 10 percent of the ground floor street side building transparency. This 10 percent is not to exceed total glass area calculated for both unattached and temporary window signs.

**Menu Boards.** One (1) single-sided menu board shall be allowed per street address. Menu boards shall not exceed six (6) square feet in size and shall be placed no further than four (4) feet from the front entrance of the restaurant or take-out food establishment. Pedestal menu signs shall not impede pedestrian movement.

## L. Prohibited Signs

1. **Signs Constituting a Traffic Hazard.** No person shall install or maintain or cause to be installed or maintained, any sign which simulates or imitates in size, color, lettering or design any traffic sign or signal, or which makes use of the words "STOP", "LOOK", "DANGER" or any words, phrases, symbols or characters in such a manner as to interfere with, mislead or confuse traffic.
2. **Signs in Proximity to Utility Lines.** Signs which have less horizontal or vertical clearance from authorized communication or energized electrical power lines that are prescribed by the applicable laws and or code are prohibited. No sign shall project above or below the sign-able area.
3. **Painted Letters.** Painted letters will not be permitted.
4. **Projections.** Wall signs may not project above the top of a parapet, the roof line at the wall, or roof line.
5. **Flashing, Moving or Audible Signs.** Flashing, moving and audible signs that are not reader boards shall be prohibited.
6. **Vehicle Signs.** Signs on or affixed to trucks, automobiles, trailers, or other vehicles which are used to advertise, identify, or provide direction to a use or activity not related to its lawful activity are prohibited.
7. **Light Bulb Strings.** External displays, other than temporary decorative holiday lighting and strings above open air, outdoor seating and plazas which consists of unshielded light bulbs, are prohibited.
8. **Banners, Pennants & Balloons Used for Advertising Purposes.** Temporary flags, banners or pennants, or a combination of same constituting an architectural feature which is an integral part of the design character of a project may be permitted subject to Code requirements.
9. **"Sale" Signs.** The use of permanent "sale" signs is prohibited. The temporary use of these signs are limited to a 30-day period and are restricted to signs affixed to the interior windows which do not occupy more than 20 percent of the window area. Each business is permitted a total of not more than 90 days of temporary window sale signs per calendar year. Note: Not applicable to Tractor Supply PUD.
10. **Storefront Decal Signs.** Signs that are affixed in a manner that covers the storefronts in full or in part in a permanent fashion. Window signs shall not be used for retail sales messages, excluding food and beverages intended for on-site consumption, and shall not cover more than 20 percent of one (1) window pane per storefront.
11. **Permanent Outdoor Advertising or Portable Advertising Structures, including signs, Balloons, Flags, Etc.**
12. **Holographic Display Signs.**
13. **Obscene Signs.**
14. **Pavement Markings, Except for Official Traffic Control Markings and Building Address Markings Required by Law.**

## M. Waivers

Because the Subject Property encompasses approximately 112 acres and may include more than 850,000 square feet of hospital and medical/professional offices and clinics; 390,907 square feet of retail commercial space; 450 multi-family residential units; 480 hotel rooms; and 250 specialty care housing units, a variety of signs are necessary to provide for the safe and efficient movement of people through the community. The Subject Property also includes uses along Interstate 95 and County Road 210, so all signage to be installed along these roadways will be designed to complement the travel experience. To accomplish these goals, the following waivers from Land Development Code Article VII are required:

1. Relief from **Section 5.03.03.F (Unified Sign Plan)** to allow a Unified Sign Plan to be a Joint Unified Sign Plan for all signs of the Fountains South (fka St. Johns Commons at CR 210) PUD (Ordinance No. 2016-56 / PUD 1998-69), Fountains North at St. Johns PUD (Ordinance No. 2020-15 / PUD 2019-03), Fountains East PUD (Ordinance No. 2020-59 / PUD 2020-09), and Tractor Supply PUD (Ordinance No. 2019-17 / PUD 2018-09) for the purposes of matching the advertising, site location and architectural needs of the end users, and allowing tenants in the PUDs to advertise along the CR 210 and Interstate 95 frontages as if combined as a single PUD.
2. Relief from **Sections 7.02.04.C, 7.02.04.D and 7.02.04.E (Number, Size and Height of Signs)** to allow the signage regulations already approved of in the existing PUD Ordinances and including the unique requirements of the hospital and causing a common vernacular amongst signs located in the various PUDs.
3. Relief from **Sections 7.02.04.B, 7.02.04.C, and 7.02.05.B.3** to allow each parcel fronting Trinity Way (formerly C.E. Wilson Road) within the Fountains North at St. Johns PUD as well as each parcel fronting on the internal access roads within the Fountains East PUD to have at least one (1) On-Premise Sign. Justification for the waivers is for any proposed signs fronting on private right-of-way instead of public right-of-way and because the sign designs and standards will be a result of matching the advertising, site location and architectural needs of the end-user in the parcels in the Fountains East PUD, which will be determined at the time of construction plan approval.
4. Relief from **Section 7.02.04.C (Ground Signs)** to allow for a Type C.3 Business Identity Monument for each of the Fountains South (fka St. Johns Commons at CR 210) PUD's five (5) outparcels and a larger ground sign at the project entrance at the intersection of Trinity Way (formerly C.E. Wilson Road) and CR 210 so that the project is announced to the public in a fashion commensurate with the way in which established commercial centers are announced with signage. This request would allow for each of the 5 outparcels to have a 150 sq. ft. ADA Type C.3 sign, up to fifteen (15) feet in height. Additionally, the entrance to the project would be allowed up to two (2) Type B.3 Project Identity Monuments 100 sq. ft. ADA per side, up to fifteen (15) feet in height.
5. Relief from **Section 7.02.04.C (Building Signs for Anchor)** to allow for one (1) anchor commercial user occupying greater than 84,000 sq. ft. of space within the Fountains South (fka St. Johns Commons at CR 210) PUD to have two (2) Anchor Tenant wall signs, one on the back of the building facing Interstate 95 and one on the front of the building facing CR 210, each having an ADA of up to 200 sq. ft. This section of the LDC states that Building Signs are limited to a maximum 150 sq. ft. per sign, not to exceed 200 sq. ft. of sign area per business. This waiver is absolutely essential to attracting an anchor commercial user to this location where industry data shows that signage is proven to greatly increase consumer traffic.
6. Relief from **Section 7.02.05.B** to allow Type A Commercial Identification Pylons to have a maximum ADA in excess of three hundred (300) square feet. Additional relief from this section to allow for Type A.2 Commercial Identification Pylons within the Tractor Supply PUD a maximum height of one hundred twenty (120) feet when situated on business sites located further than five hundred (500) feet from Interstate 95 right-of-way. This relief is justified based on the disposition, mixture of uses and dimensions of the Subject Property and to allow for consistency among the PUDs. The larger signage will allow for northbound and southbound Interstate 95 travelers to identify the hospital and PUD lodging, offices, and businesses earlier and provide enough time to safely make the necessary exits off of the interstate. If the maximum sizes of the signs are limited to the sizes permitted in the LDC, travelers may pass the off-ramps by the time they notice the signs identifying Project signage.
7. Relief from **Section 7.02.06.B (Ingress, Egress, or Direction Signs)** to allow public information signage (wayfarer signs) with ADA greater than three (3) square feet and more than three (3) feet in height within the PUDs at internal road intersections and along internal roadways and sidewalks. To safely direct visitors to the various medical offices, hospital facilities, and businesses located within the PUDs, multiple Public

Information Signs may be needed in sizes large enough to be visible to motorists. For example, upon entering the primary access point, customers seeking to patronize a business located at an outparcel will be directed by public information signage so they know whether to turn left, right, or proceed straight. Further, the project contemplates an anchor retailer and such anchor retailers require increased signage. Such signage will be outside of the public right-of-way.

8. Relief from **Sections 7.02.07, 7.06.01.B, 7.06.02.A.3 and 7.08.01.T (Sign Placement Limits)** to allow for on-premise permanent signs, and/or portions thereof, to be located within public rights-of-way as long as the Owner enters into a maintenance agreement with the County placing maintenance responsibility for such signs on the Owner, its successors or assigns.
9. Relief from **Section 7.05.01.D and E (Special Event Signs)** to permit banners used in conjunction with temporary and special events that are not limited as to number and duration. Decorative banners may also be placed on streetlight poles and shall not count toward the overall maximum advertising display area allowed for monument and pylon signs. Such banners may be displayed for more than 120 days per calendar year and for more than three (3) special events per year.
10. Relief from **Sections 7.06.01 and 7.06.02 (Project Identification)** to allow more than one (1) Type A Commercial Identity Pylon to display the name, logo and/or symbol of the primary business or organizations located within the PUDs. And cannot be located closer than one hundred (100) feet from one another.

# Appendix 1

## Conceptual Graphics

The Appendix includes depictions of sign materials, colors and shapes that are conceptual illustrations of the general character of signage to be located within the Subject Property. These concepts are subject to change and modification including, but not limited to, changes in shape, layout, and location of ADA.



## **Project Signage**

Primary Identity Monument

Project Identity at Fountain

Project Identity at Entrance

Outparcel Ground Signage

Directional Wayfinding

Pedestrian Wayfinding

Pedestrian Gateway

Tenant Building Signs

Street and Traffic Signs

Flags

Project Construction Signs

Temporary Signs

Special Use Signs

# Sign Type B.3: Primary Identity Monument

## Sign Description

This sign type marks the entry threshold into the Fountains site and interior parcels. These signs will be placed at vehicular arrival points or driveways as part of landscaping transitions and pedestrian sidewalks. The signs will include the project identity and possibly tenant(s). The columns will not contain any advertising Display Area. The columns may include stamped concrete design elements intended to repeat the brand and character of the neighborhood. Concrete design elements are for decorative purposes and are not part of Advertising Display Area.

Shall be a monument style sign. This sign design is characterized by a blend of vehicular-oriented and pedestrian-level heights, consistency of materiality with the architecture, limited pops of color, and landscaping to soften the pedestal of the sign (note landscape to be included on landscape plan(s)).

Two (2) 100 square foot faces are permitted in the PUD with a 15-foot overall height. The sign may have a directory sign, but only within the 100 square feet (200 square foot total, 100 each side).

## Materials

Wood, masonry, fiber cement, brick or stone.

## Mounting

Ground mounted, structure to extend into engineered footing.

## Lighting

Ground mounted lighting, white in color.

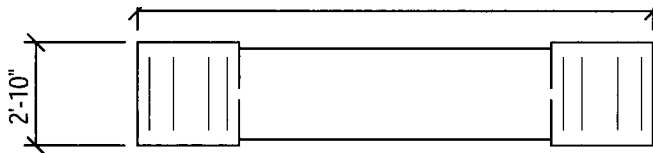

## PLAN VIEW

Scale: 3/16" = 1'-0"

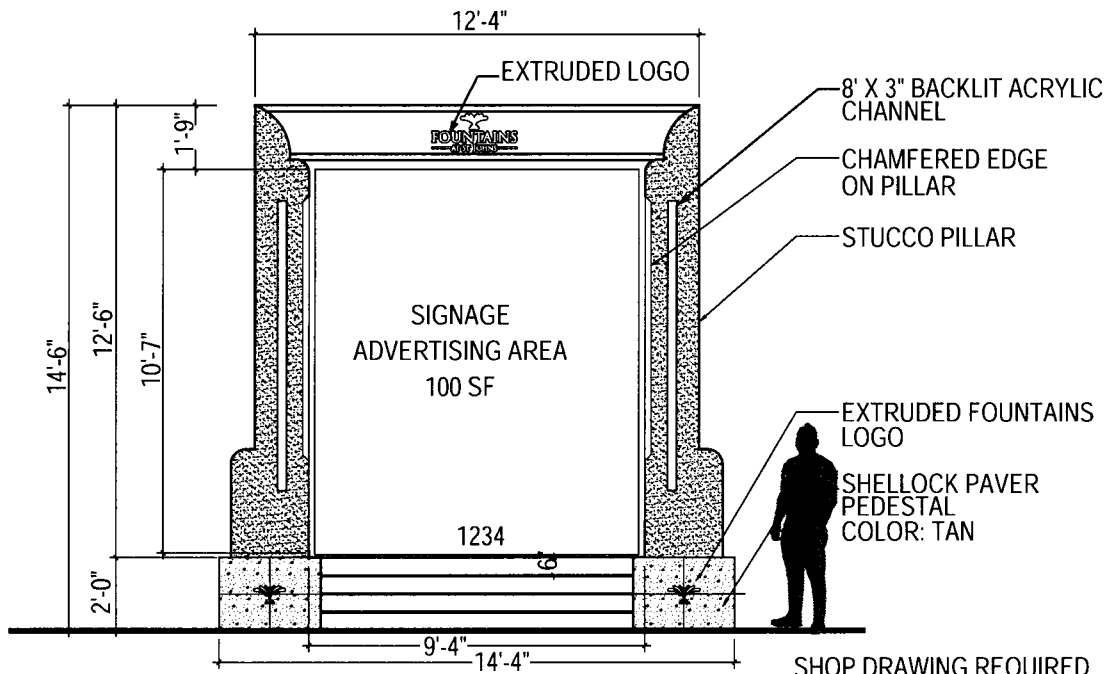

## ELEVATION: PROJECT IDENTITY MONUMENT

Scale: 3/16" = 1'-0"

SHOP DRAWING REQUIRED

# Sign Type B.4: Project Identity at Fountain

## Sign Description

This sign type is located at the fountain at Fountains South and is the feature element as drivers enter into the parcel. The sign is individual ground-lit letters.

## Materials

Aluminum.

## Mounting

Mounted to coping capstone.

## Lighting

Ground mounted lighting, white in color.

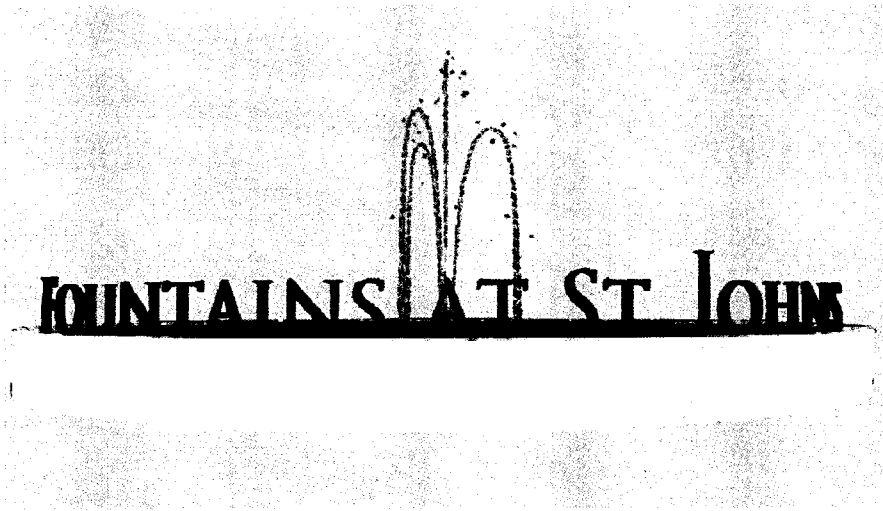

PERSPECTIVE



## ELEVATION: PROJECT IDENTITY AT FOUNTAIN

Scale: 3/16" = 1'-0"

# Sign Type B.5: Project Identity at Entrance

## Sign Description

This sign is the entry feature on CR210 as drivers approach Fountains South. The sign will include the project identity, water feature and landscaping. The columns will not contain any advertising Display Area. The columns may include stamped concrete design elements intended to repeat the brand and character of the neighborhood. Concrete design elements are for decorative purposes and are not part of Advertising Display Area.

Shall be a monument style sign. This sign design is characterized by a blend of vehicular-oriented and pedestrian-level heights, consistency of materiality with the architecture, limited pops of color, and landscaping to soften the pedestal of the sign (note landscape to be included on landscape plan(s)).

One (1) 100 square foot face is permitted in the PUD with a 15-foot overall height.

## Materials

Wood, masonry, fiber cement, brick or stone.

## Mounting

Ground mounted, structure to extend into engineered footing.

## Lighting

Ground mounted lighting, white in color.

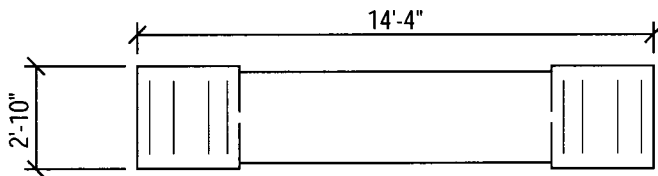

## PLAN VIEW

Scale: 3/16" = 1'-0"

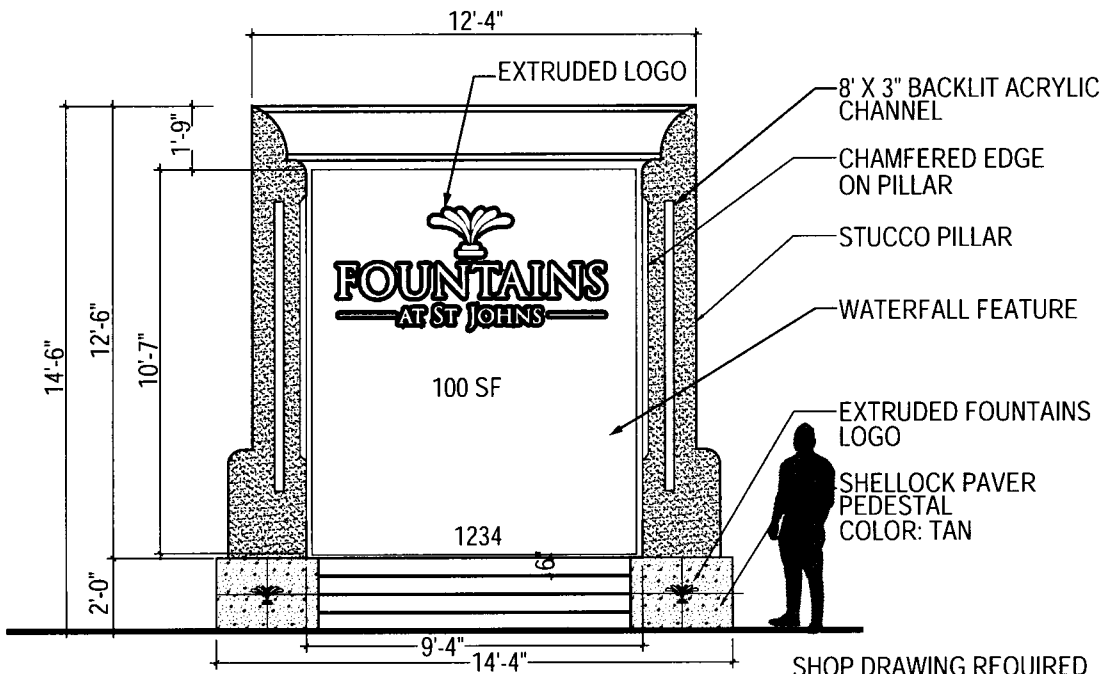

## ELEVATION: PROJECT IDENTITY AT ENTRANCE

Scale: 3/16" = 1'-0"

# Sign Type B.6: Primary Identity Monument

## Sign Description

This sign type marks the entry threshold into the Fountains site and interior parcels. These signs will be placed at vehicular arrival points or driveways as part of landscaping transitions and pedestrian sidewalks. The signs will include the project identity and possibly tenant(s). The columns will not contain any advertising Display Area. The columns may include stamped concrete design elements intended to repeat the brand and character of the neighborhood. Concrete design elements are for decorative purposes and are not part of Advertising Display Area.

Shall be a monument style sign. This sign design is characterized by a blend of vehicular-oriented and pedestrian-level heights, consistency of materiality with the architecture, limited pops of color, and landscaping to soften the pedestal of the sign (note landscape to be included on landscape plan(s)).

## Materials

Wood, masonry, fiber cement, brick or stone.

## Mounting

Ground mounted, structure to extend into engineered footing.

## Lighting

Ground mounted lighting, white in color.

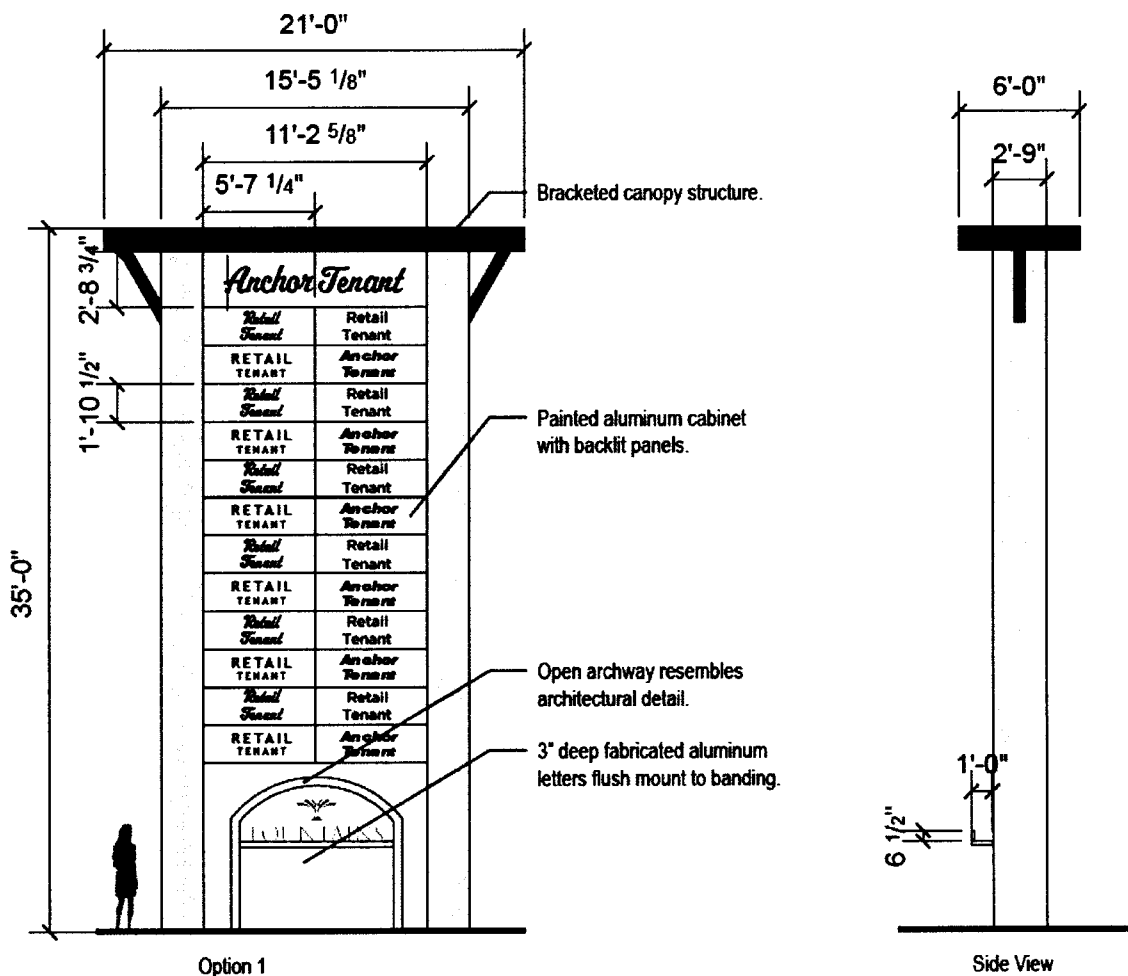

**ELEVATION: PROJECT IDENTITY MONUMENT**  
Scale: 3/16" = 1'-0"

# Sign Type C.3: Outparcel Signage

## Sign Description

The sign shall be used for all Monument Style Signs for CR210 outparcels. Per the PUD, a total of five (5) are permitted with 150 square feet total of advertising area per sign, which is shown as 75 sf per side. If allowed in the pending PUD minor modification, these will also be allowed for the western office buildings as well if in scale with the building.

This sign reflects a pedestrian scale and subtle detailing to allow business titles to pop, while keeping with the aesthetic vocabulary throughout the development.

Landscaping, which includes native shrub massings and other plantings, are to be placed at the base of all monument signs. Shrubs around the sign base shall be selected not to exceed three feet (3') at maturity. Base detailing should be revealed in certain areas (not fully landscaped at the base; no more than 70%).

## Materials

Metal, stucco, shellock paver pedestal, acrylic, paint.

## Mounting

Ground mounted, structure to extend into engineered footing.

## Lighting

Ground mounted lighting, white in color.

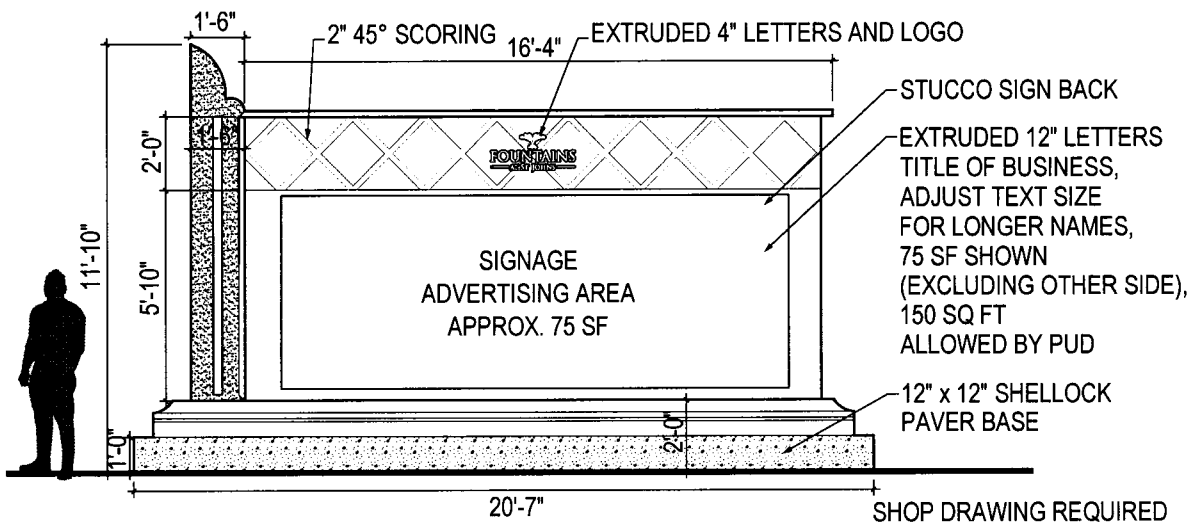

## ELEVATION: OUTPARCEL SIGNAGE

Scale: 3/16" = 1'-0"

# Sign Type E: Directional Wayfinding

**Sign Description**

There is no limit to the amount of public information signs (directional / building directory) allowed in the PUD.

NOTE: If allowed in the pending PUD minor modification, these will also be required for the western office buildings as well. The below language assumes this is the case.

For properties located westward on northward of Buildings 1-4, Public Information Signs (i.e. "Directory" signs) are to be used. As shown in the design (Figure 9), the overall height shall be 8' with 32 square feet total of signage area per side (may be single or double, but 32 square feet is maximum). Signs shall be placed at intersections / decision points and outside buildings with tenants, per the PUD.

**Materials**

Metal, stucco, shellock paver pedestal, acrylic, paint.

**Mounting**

Ground mounted, structure to extend into engineered footing.

**Lighting**

Ground mounted lighting, white in color.

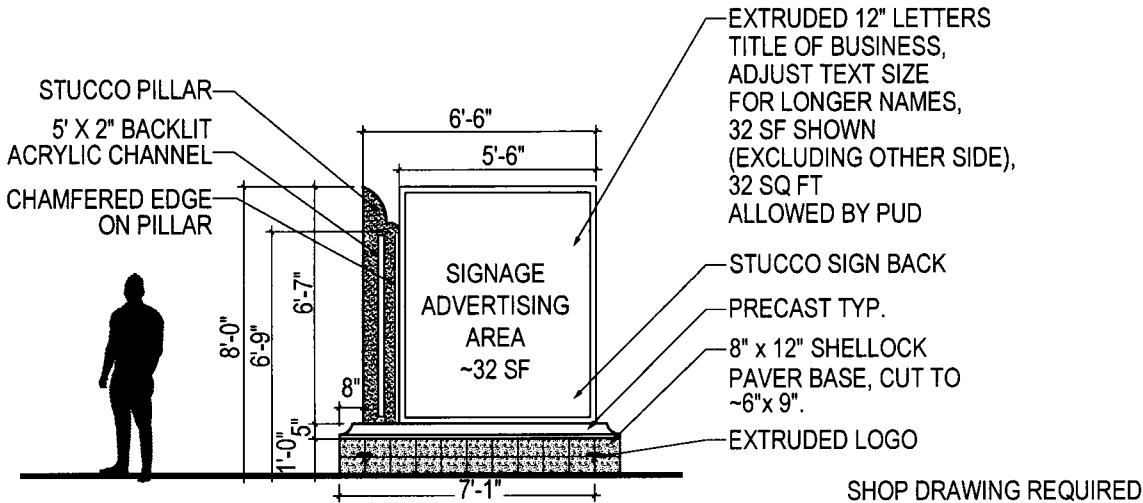

**ELEVATION: DIRECTIONAL WAYFINDING**

Scale: 3/16" = 1'-0"

# Sign Type F: Pedestrian Wayfinding

## Sign Description

Pedestrian wayfinding signs shall be allowed to provide patrons with directional information regarding uses and tenants within the PUD: Directional signs will comply with LDC Section 7.02.06.B.

## Materials

Metal, stucco, shellock paver pedestal, acrylic, paint.

## Mounting

Ground mounted, structure to extend into engineered footing.

## Lighting

Ground mounted lighting, white in color.

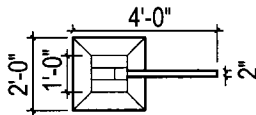

### PLAN VIEW

Scale: 3/16" = 1'-0"

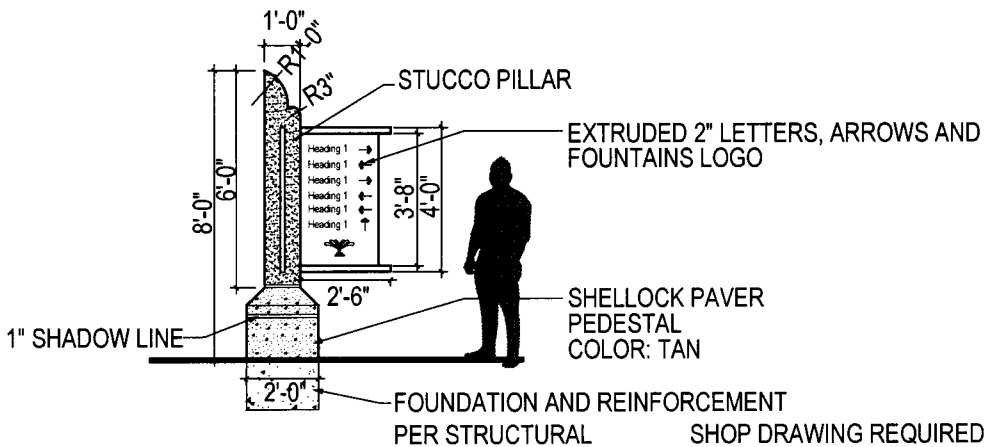

### ELEVATION: PEDESTRIAN WAYFINDING

Scale: 3/16" = 1'-0"



# Details: Scalloped Column Proportion & Facade Medallion

## Sign Description

Certain elements deemed "signature" elements to the Fountains of St. Johns are designed to be incorporated in feature areas of all buildings on the site. These elements include:

- Signature scalloped column top.
- Utilization of precast façade medallions extending the "Fountains at St. Johns" brand are recommended. See Figure 4 for the approved medallion.
- Decorative scoring of 45 degree square grid.

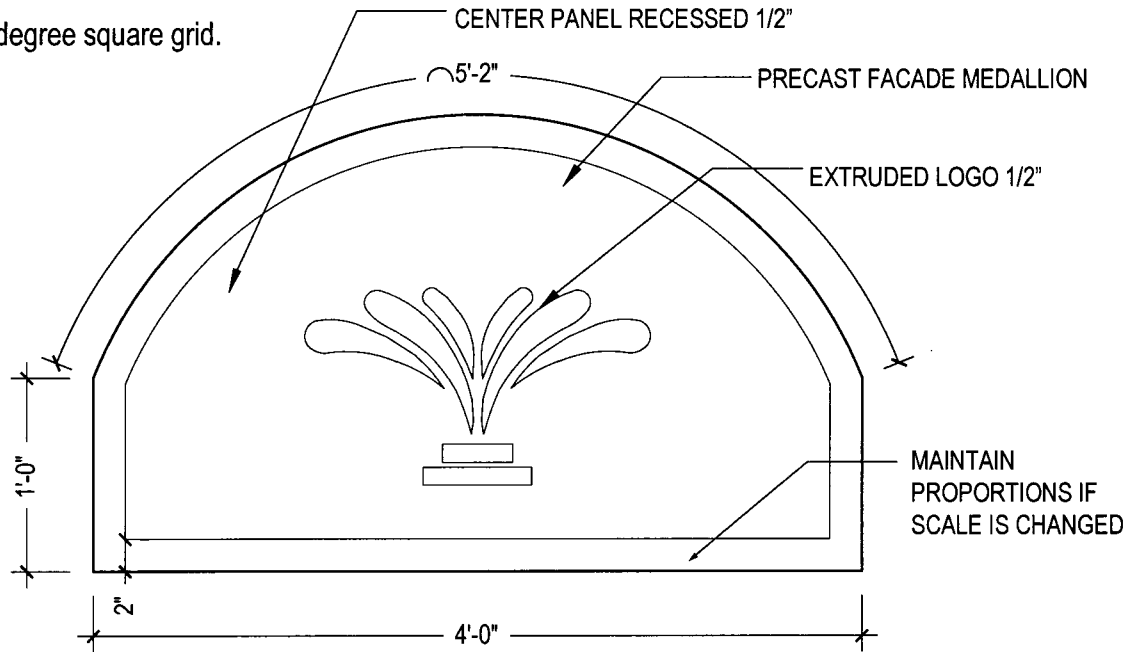

**DETAIL: PRECAST FACADE MEDALLION**

Scale: 1" = 1'-0"

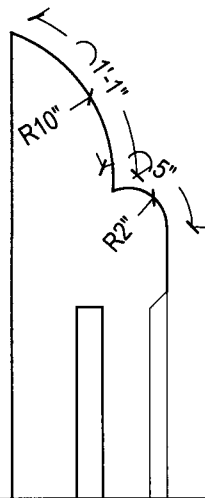
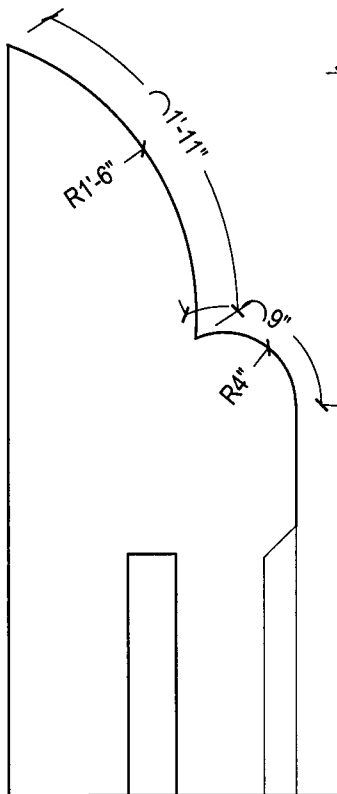

**SCALLOP COLUMN DETAIL PROPORTION**

ARC LENGTH  
 TOP CURVE: 2.5X  
 BOTTOM CURVE: 1X  
 (APPROX.)

ARC RADIUS  
 TOP CURVE: 4.5X  
 BOTTOM CURVE: 1X  
 (APPROX.)

**DETAIL: SCALLOPED COLUMN PROPORTION**

Scale: 1" = 1'-0"

# Sign Type G: Pedestrian Gateway

## Sign Description

This sign will be located along pedestrian pathways at the Fountains East parcel to add to the overall ambiance and reinforce the project brand.

This sign reflects a pedestrian scale and subtle detailing, while keeping with the aesthetic vocabulary throughout the development.

## Materials

Metal, paint.

## Mounting

Ground mounted, structure to extend into engineered footing.

## Lighting

Ground mounted lighting, white in color.

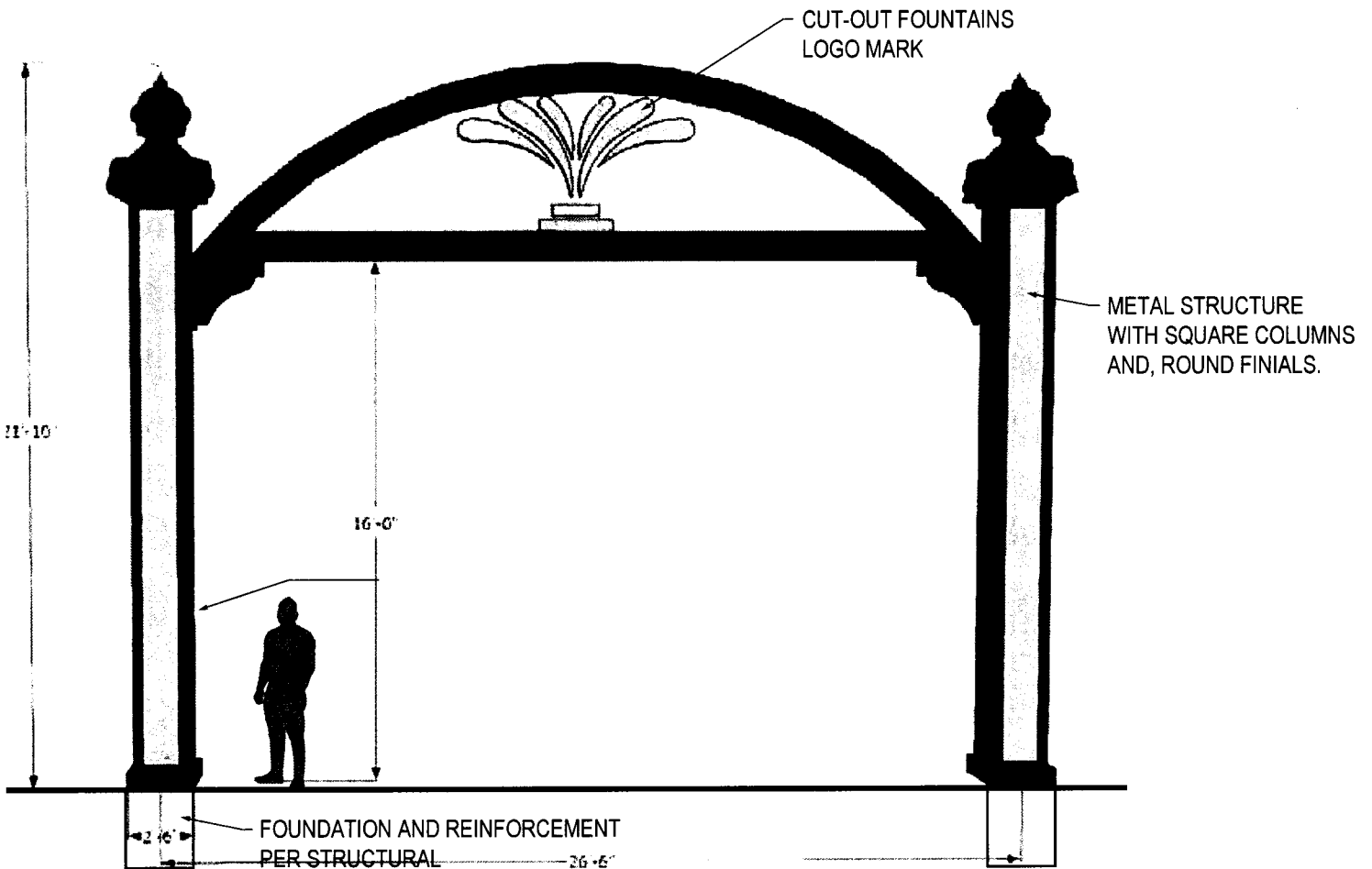

## ELEVATION: PEDESTRIAN GATEWAY

Scale: 3/16" = 1'-0"

SHOP DRAWING REQUIRED

# Sign Type H: Tenant Building Sign

## Sign Description

All signs connected to the façade of a business shall be black extruded lettering, not exceeding 3" in depth. All transformers must be concealed, with no visible raceways. Signage regulated by the St. Johns County Land Development Code (LDC).

## Mounting

Pin-mounted from facade and centered over storefront.

## Lighting

Halo illuminated with white LED.

## Materials

Painted aluminum channel letters.

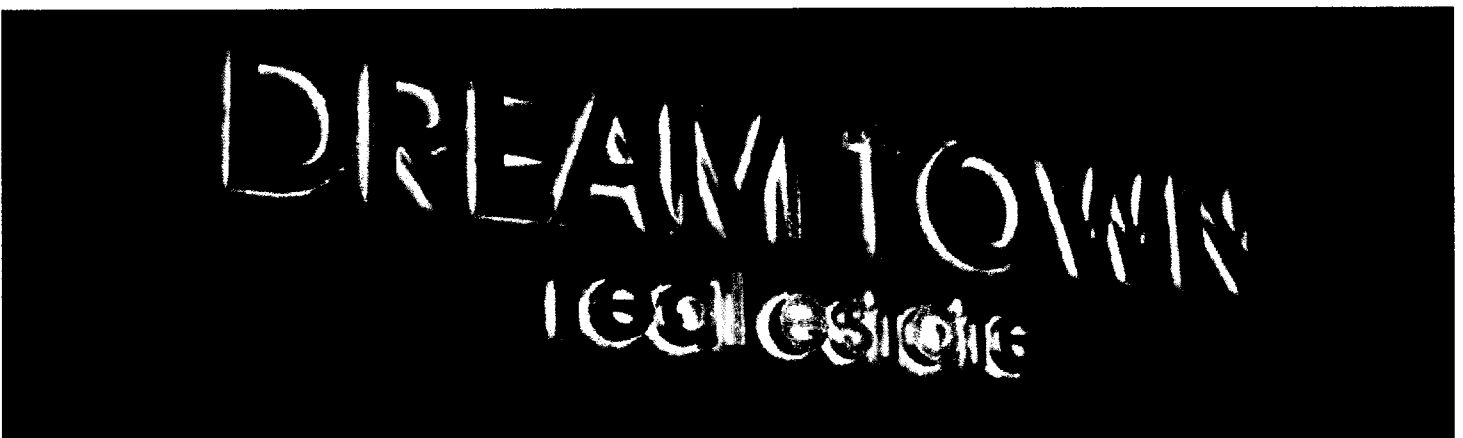

## REFERENCE: TENANT BUILDING SIGN

Scale: N.T.S.

# Sign Types

## **Sign Type I: Street and Traffic Sign**

### Sign Description

Street and traffic signs will be installed to comply with all laws, codes and ordinances with regard to size and location. The style will be consistent with standard road signs utilized throughout the county.

## **Sign Type J: Flags**

### Sign Description

Up to three permanent flags may be flown per business site and office site, as specified in LDC Section 7.02.06. For purposes of this USP, a business or office site shall be defined as a unit of property that is owned, leased or rented and serves as an occupied place of business within the PUD. Flag pole heights shall not exceed 30 feet. Temporary flags will comply with the requirements of LDC Section 7.02:02 and 7.02.03.

## **Sign Type K: Project Construction Sign**

### Sign Description

Project construction signs will be considered temporary signs and installed in accordance with LDC Sections 7.02.02 and 7.02.03.

## **Sign Type L: Temporary Sign**

### Sign Description

Temporary signs will be allowed and installed in accordance with LDC Sections 7.02.02 and 7.02.03.

## **Sign Type M: Special Event Sign**

### Sign Description

Special event signs will be allowed and installed in accordance with LDC Sections 7.05.00 and 7.02.03,

# Appendix 2

## Tenant Signage Criteria (Fountains South PUD)

# The Fountains South

## tenant signage criteria manual

August 24, 2021



api(+)

apiplus.com 2709 Rocky Point Dr. 201 Tampa, Florida 33607 USA T 813 + 281 9299

# Table of Contents

|  |      |
|--|------|
| Table of Contents                                      | 0.1  |
| Project Team   | 0.2  |
| <b>Part 1: General Provisions &amp; Guidelines</b>     |      |
| Introduction & Design Approach                         | 1.1  |
| Construction Photos                                    | 1.2  |
| Submission Requirements & Permitting                   | 1.3  |
| Base Building Materials and Colors                     | 1.4  |
| Fountains South Overview Map                           | 1.5  |
| Fountains South: Building 1 Plan                       | 1.6  |
| Fountains South: Building 1 Elevations                 | 1.7  |
| Fountains South: Building 2 Plan                       | 1.8  |
| Fountains South: Building 2 Elevations                 | 1.9  |
| Fountains South: Building 7-10 Elevations              | 1.10 |
| <b>Part 2: Tenant Sign Type Criteria</b>               |      |
| Sign Type 1a: Primary Building ID - Individual Letters | 2.1  |
| Sign Type 1b: Primary Building ID - Individual Letters | 2.2  |
| Sign Type 2: Primary Building ID - Canopy              | 2.4  |
| Sign Type 3: Primary Building ID - Blade               | 2.6  |
| Sign Type 4: Blade Sign                                | 2.8  |
| Sign Type 5: Monument Sign                             | 2.9  |
| Sign Type 6: Window Graphics                           | 2.10 |

\* Tenant's architect should obtain Lease Outline Drawings (LOD's) specific to tenant space and frontage from the Landlord prior to commencing design. Tenant's architect should have a copy of the Tenant Lease Agreement from Tenant which further defines Landlord's and Tenant's design and construction responsibilities.

# Project Team

**Landlord:**

DAR Investments One, LLC  
1205 Monument Rd, Ste 303  
Jacksonville, FL 32225

**Developer:**

Cross Regions Group  
David Ergisi, CCIM - President, CEO  
13553 Atlantic Blvd., Suite 201  
Jacksonville, FL 32225  
david.ergisi@crossregions.com

**Construction Manager:**

D B Kenyon  
5772 Timuquana Rd  
Jacksonville, FL 32210  
904.777.0833

**Architect:**

D. Scott Fraser, Architect  
P.O. Box 555  
Middleburg, FL 32050  
T 904.571.2373  
fraserrtx@aol.com

**Leasing And Retail Consultant:**

Cross Regions Real Estate  
13553 Atlantic Blvd., Suite 201  
Jacksonville, FL 32225  
904.242.6555

**Fabricator:**

Harbinger  
Ed Busey - VP of Business  
Development  
5300 Shad Rd. Jacksonville, FL  
32257  
T 904.629.8201  
edb@harbingersign.com

**Graphics Consultant:**

api(+)  
John Scheffel, Vice President -  
Visual Design  
2709 Rocky Point Drive #201  
Tampa, FL 33607  
T 813.281.9299  
jscheffel@apiplus.com





## **Part 1: General Provisions & Guidelines**

*Introduction & Design Approach*

*Construction Photos*

*Tenant Submission Requirements & Permitting*

*Base Building Materials and Colors*

*The Fountains South Overall Plan*

*The Fountains South: Building 1 Plan*

*The Fountains South: Building 1 Elevations*

*The Fountains South: Building 2 Plan*

*The Fountains South: Building 2 Elevations*

# Introduction & Design Approach

## Introduction

The Fountains at St. Johns another quality development by Cross Regions Real Estate. Located in the heart of one of the fastest growing corridors in Northeast Florida, The Fountains will be a premier shopping and work destination in Northern St Johns County. Located ¼ miles from I-95 on CR 210 West, the center is ideally located to accommodate Nocatee, Beachwalk, St John's Forest and all the new exciting residential communities being developed in that area. Once completed, the Mixed-Use Development will bring together approximately 80,000 sf of Medical office users and over 100,000 sf of retail to create the perfect opportunity to dine, shop, work, and entertain in an upscale environment!

## Design Approach

Tenant signage is a major component of the overall visual environment. Imaginative, progressive and creative signage provided by the tenant is an essential and energizing part of the upmarket retail environment. Accordingly, the Landlord encourages Tenant signage executed in a manner not commonly seen in other retail environments and will discourage designs that are unimaginative or prototypical.

The signage criteria manual is intended to provide general guidelines, but we encourage and will consider "out of the box" design concepts. Be imaginative!

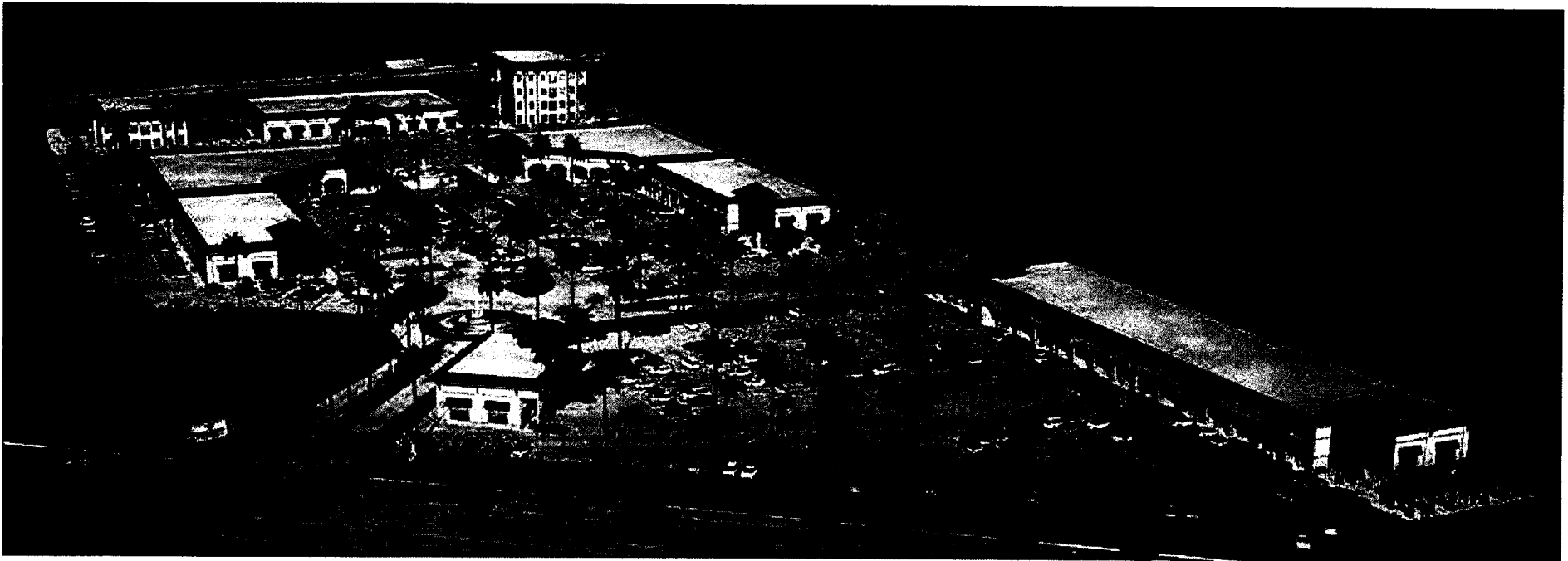

# Construction Photos

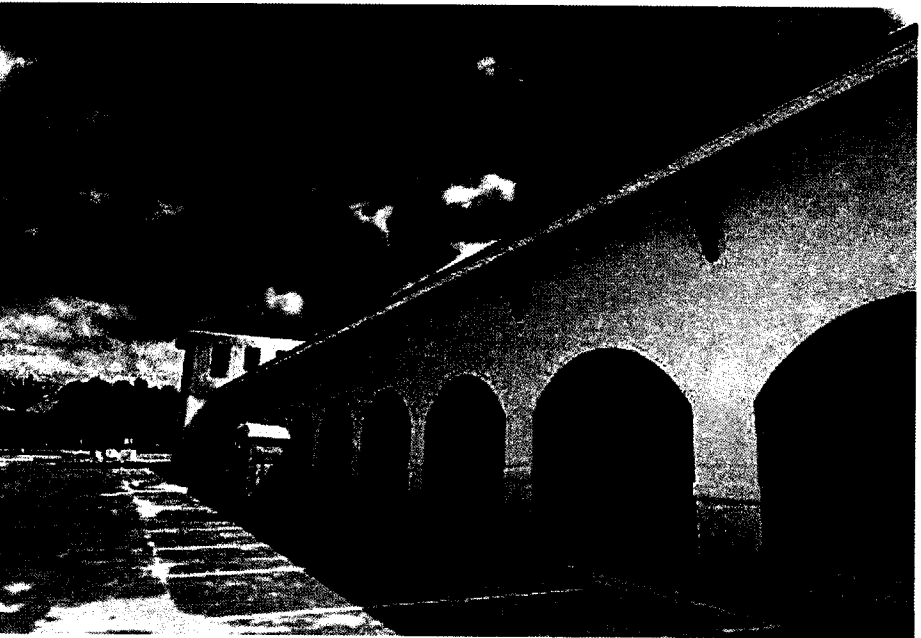

# Tenant Submission Requirements & Permitting

## Local Sign Codes and Permitting

Signs are regulated by The Fountains South Sign Plan, which meets requirements of the St. John's County City Code. Sign Permits are issued through the County and are required prior to the erection of any temporary or permanent sign. Review and written approval from the Landlord or the Landlord's representative is required before applying for sign permits.

## Submittals

Prior to starting construction, Tenant shall provide complete construction drawings and specifications, in a preliminary and then final submission, for the construction of its Tenant Signage in order to receive landlord's written approval. Tenant shall reimburse Landlord \$100.00 for its review of cost at time of submission to Landlord for each submission. No work shall be performed by Tenant until Landlord has approved all drawings. The drawing submissions shall be known as Preliminary or Design Phase (Submission I) and Final or Construction Drawing Phase (Submission II). For each submittal phase, Tenant shall provide three (3) sets of prints and one (1) electronic version. All drawings and specifications must be clearly identified with project name, Tenant's store name and Tenant's space designation. **Refer to lease agreement for submission time table.**

**Failure to provide adequate information at any phase will result**

**in the return of the submission with no review.** The submission at design phase must be complete in order to properly evaluate the proposal and prevent continuation of work on an unacceptable storefront design.

Submittals for review will include the following:

- Fully dimensioned Shop Drawings
- Material and color specifications
- Installation methods
- Dimensioned elevation of the Tenant Space with the location(s) of the sign(s) indicated by dimension.

Submittals shall be forwarded to:

## Cross Regions Group

Cross Regions Group is a Global Company operating in Real Estate with focus on Ground Up Development, Brokerage, Advisory Services, Construction, Acquisitions and Property Management Services. Cross Regions International investment platform offers different advantages to Local and Foreign Investors interested in diversifying their Capital holdings. Our skilled and experienced team is equipped to offer you the best advice in many different areas of investments. We can advise you on the most suitable and advantageous options in each step when choosing, purchasing, financing and managing your investment.

# Base Building Materials and Colors

## Base Building Materials

- Traditional drywall and stucco (cement plaster) painted. Off-white color
- Aluminum storefront. dark bronze lower level, champagne upper level.
- Bronze metal accents.
- Dark charcoal roof tile.

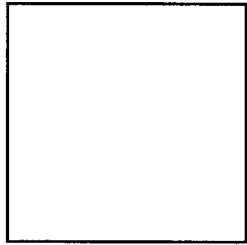

DRYWALL  
WHITE OPULENCE



CANOPIES - DARK  
ANODIZED BRONZE



BORAL ROOF  
DARK CHARCOAL  
BLEND

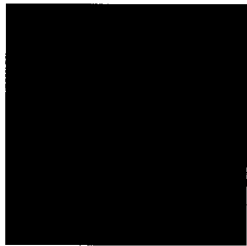

LOWER STOREFRONT  
- DARK BRONZE

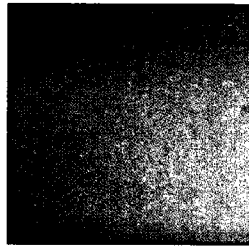

UPPER STOREFRONT  
- CHAMPAGNE

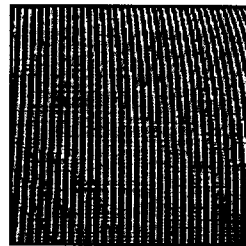

AWNINGS -  
SUNBRELLA  
LINEN TWEED



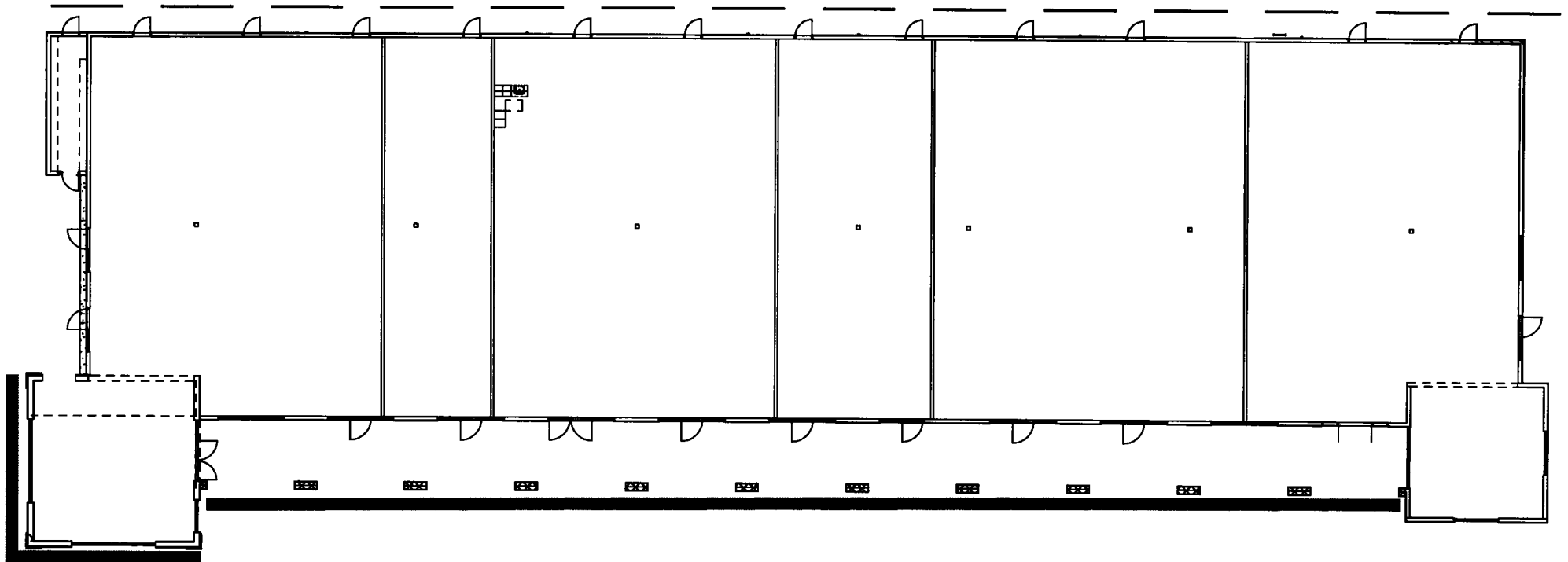

# The Fountains South: Building 1 Plan



## PLAN VIEW: BUILDING 1

Scale: 1/32" = 1'-0"

-  STOREFRONT TYPE A  
(SIGN TYPE 1a, 4)
-  STOREFRONT TYPE B  
(SIGN TYPE 1b, 2)

**Note: Building 4 is nearly a mirror image of Building 1**

LEASE PLAN SUBJECT TO CHANGE  
REFER TO LEASE AGREEMENT EXHIBIT "A"

# The Fountains South: Building 1 Elevations

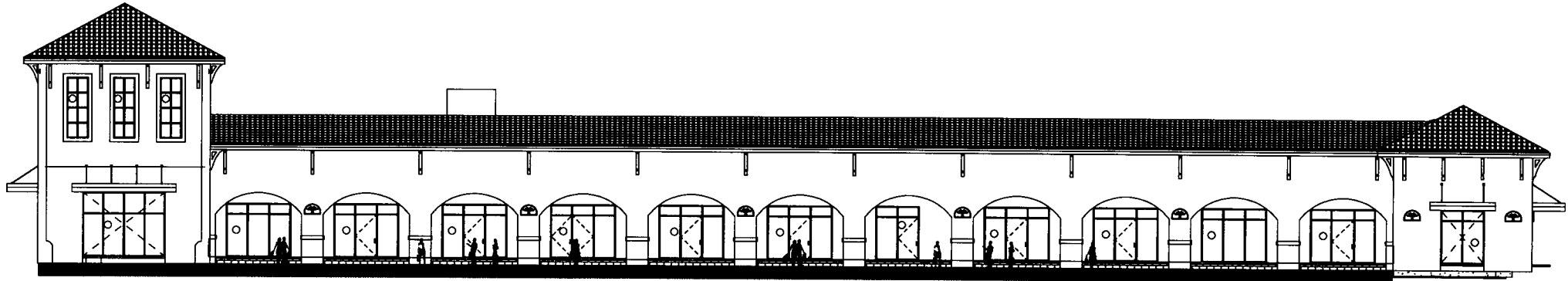

FRONT ELEVATION

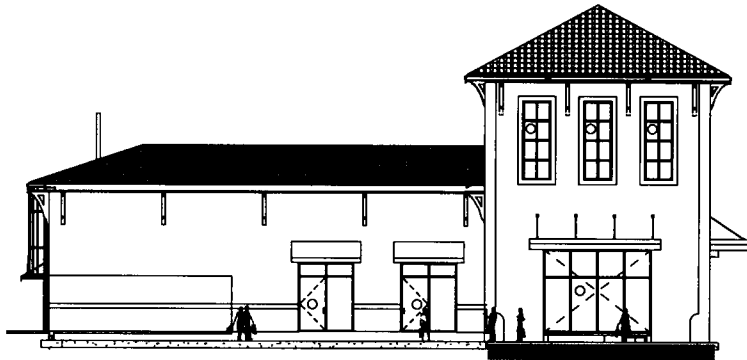

LEFT ELEVATION



RIGHT ELEVATION

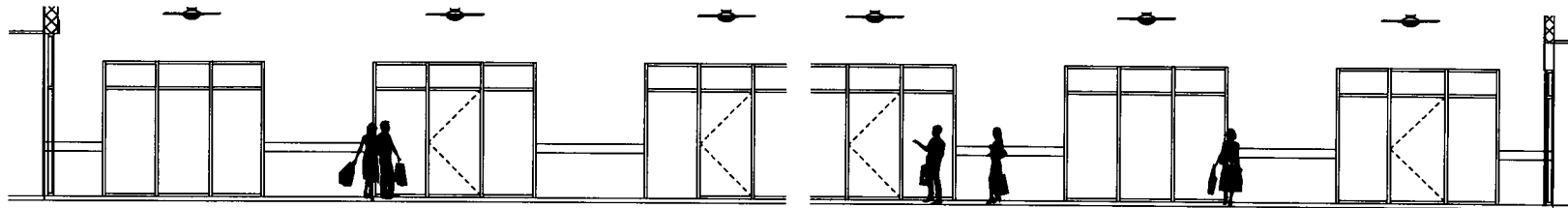

STOREFRONT ELEVATION

## ELEVATIONS : BUILDING 1

Scale: 1/32" = 1'-0"

- STOREFRONT TYPE A  
(SIGN TYPE 1a, 4)
- STOREFRONT TYPE B  
(SIGN TYPE 1b, 2)

**Note: Building 4 is nearly a mirror image of Building 1**

LEASE PLAN SUBJECT TO CHANGE  
REFER TO LEASE AGREEMENT EXHIBIT "A"



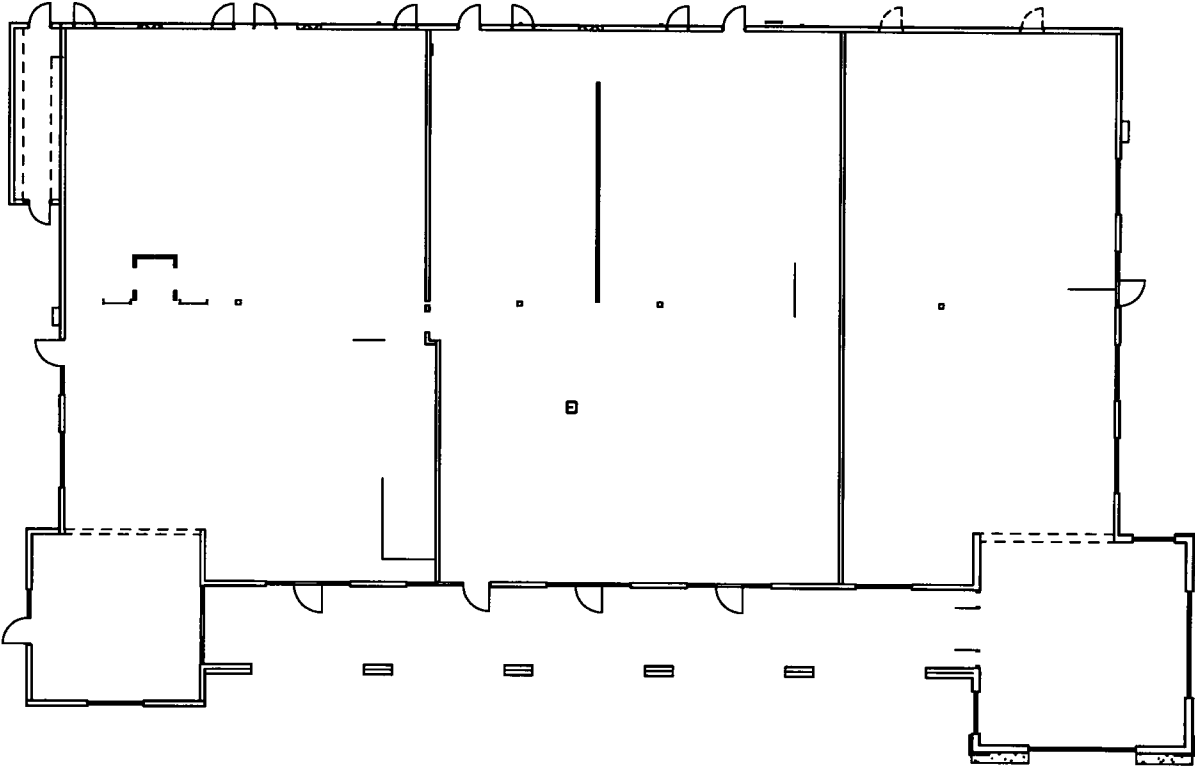

# The Fountains South: Building 2 Plan



**PLAN VIEW: BUILDING 2**

Scale: 1/32" = 1'-0"

-  STOREFRONT TYPE A  
(SIGN TYPE 1a, 4)
-  STOREFRONT TYPE B  
(SIGN TYPE 1b,2)

**Note: Building 3 is a mirror image of Building 2**

LEASE PLAN SUBJECT TO CHANGE  
REFER TO LEASE AGREEMENT EXHIBIT "A"

# The Fountains South: Building 2 Elevations

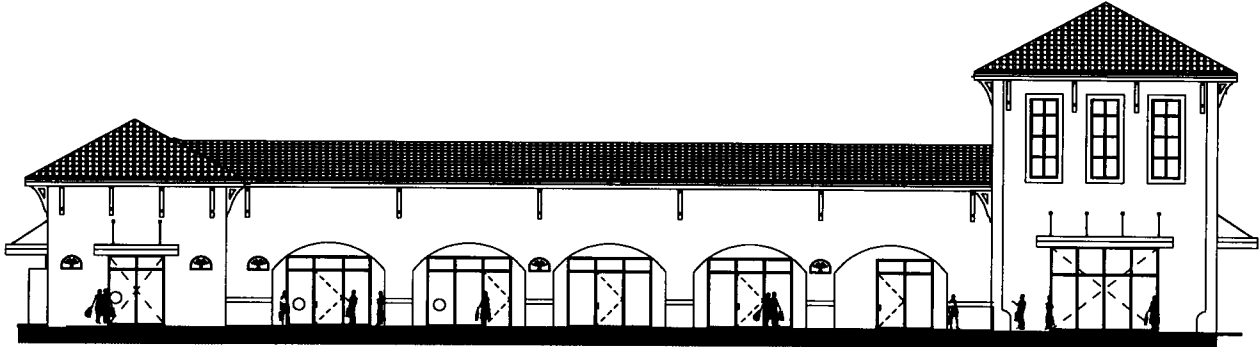

FRONT ELEVATION

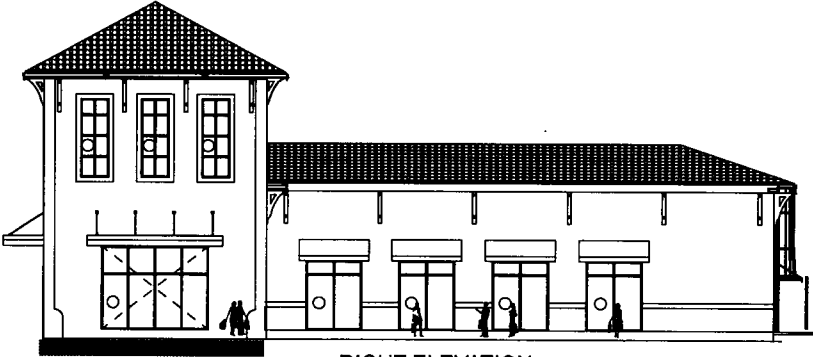

RIGHT ELEVATION

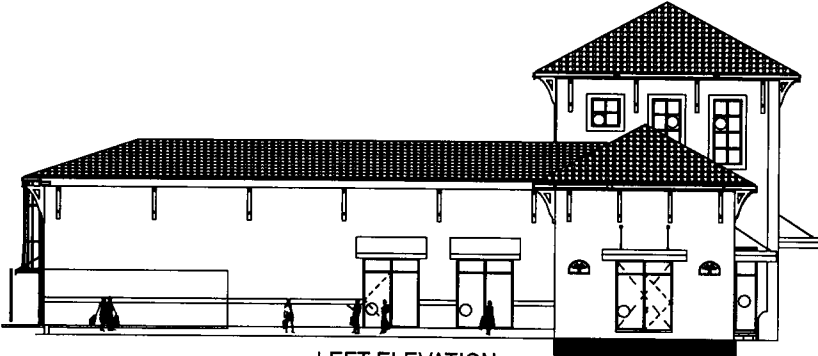

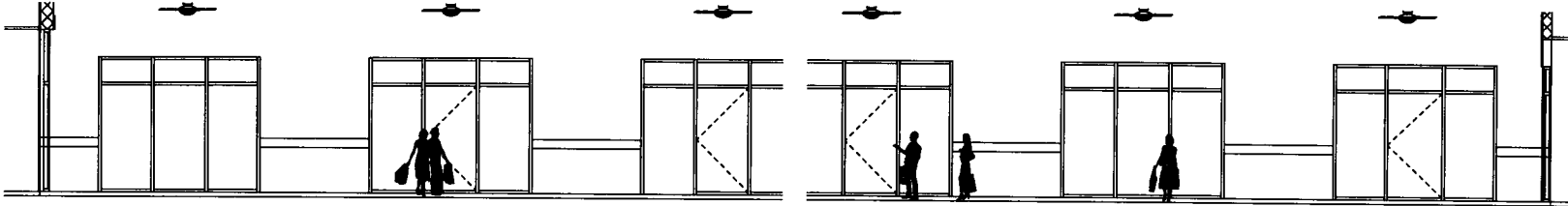

LEFT ELEVATION



STOREFRONT ELEVATION

**ELEVATIONS : BUILDING 2**

Scale: 1/32" = 1'-0"

-  STOREFRONT TYPE A (SIGN TYPE 1a, 4)
-  STOREFRONT TYPE B (SIGN TYPE 1b, 2)

**Note: Building 3 is a mirror image of Building 2**

LEASE PLAN SUBJECT TO CHANGE  
REFER TO LEASE AGREEMENT EXHIBIT "A"

# The Fountains South: Building 7 Elevations



FRONT ELEVATION

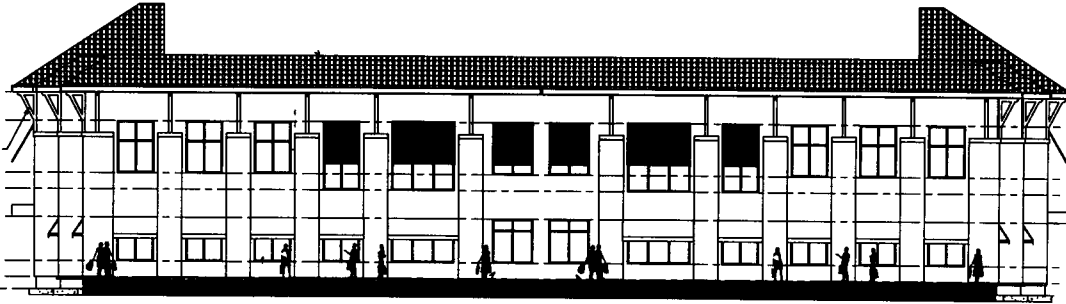

BACK ELEVATION

**ELEVATIONS : BUILDING 7**

Scale: 1/32" = 1'-0"



STOREFRONT TYPE A  
(SIGN TYPE 1a, 4)



STOREFRONT TYPE C  
(SIGN TYPE 1b)



STOREFRONT TYPE B  
(SIGN TYPE 1a, 2)

**Note: Building 7 is a mirror image of Building 10**

LEASE PLAN SUBJECT TO CHANGE  
REFER TO LEASE AGREEMENT EXHIBIT "A"

## Part 6: Tenant Sign Type Criteria

Sign Type 1a: Building ID - Individual Letters

Sign Type 1b: Building ID - Individual Letters

Sign Type 2: Building ID - Concoy Letters

Sign Type 3: Building ID - Blade Sign

Sign Type 4: Blade Sign

Sign Type 5: Monument Sign

Sign Type 6: Window Graphics

# Sign Type 1a: Primary Building ID - Individual Letters

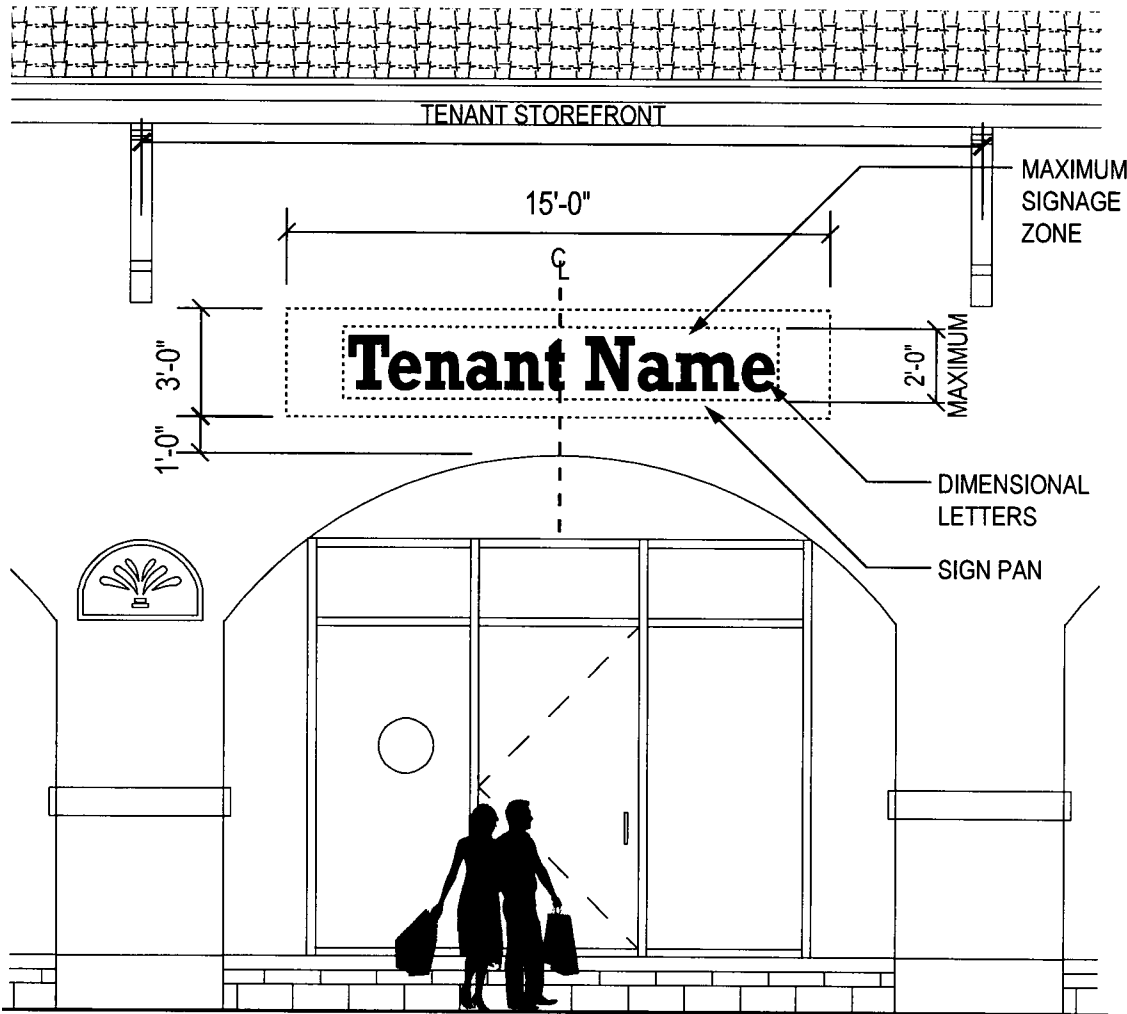

**ELEVATION: SIGN TYPE 1a - INDIVIDUAL LETTERS**

Scale: 3/16" = 1'-0"

## General Guidelines

- Tenants in storefront types A and B are allowed one (1) wall-mounted building identity sign. Tenants with multiple facings may be allowed up to two (2) signs. Tenants in storefront type C refer to Sign Type 1b.
- Signage to remain within the zone indicated. Total sign area not to exceed 1.00 square feet per linear foot of frontage. Total length of sign not to exceed 12'-0".
- Letters to be halo-lit with 5,000 kelvin illumination. Illuminated portion to be white and rest of letter to match the project matte black color. Letters to be 3" deep and pin-mounted 1/2" to a 15'-0" x 3'-0" x 1" deep aluminum pan with spray texture to match the building's stucco finish. Said pan will be provided by tenant's signage contractor.
- All transformers are to be concealed with no visible raceways.

## Allowed

- Halo-lit illuminated channel letters.
- Tenant logotype.

## Restricted

- Tenant logomark (with Landlord approval).
- Tag Line (with Landlord approval).
- Tenant brand colors.
- Raceways.

# Sign Type 1b: Primary Building ID - Individual Letters

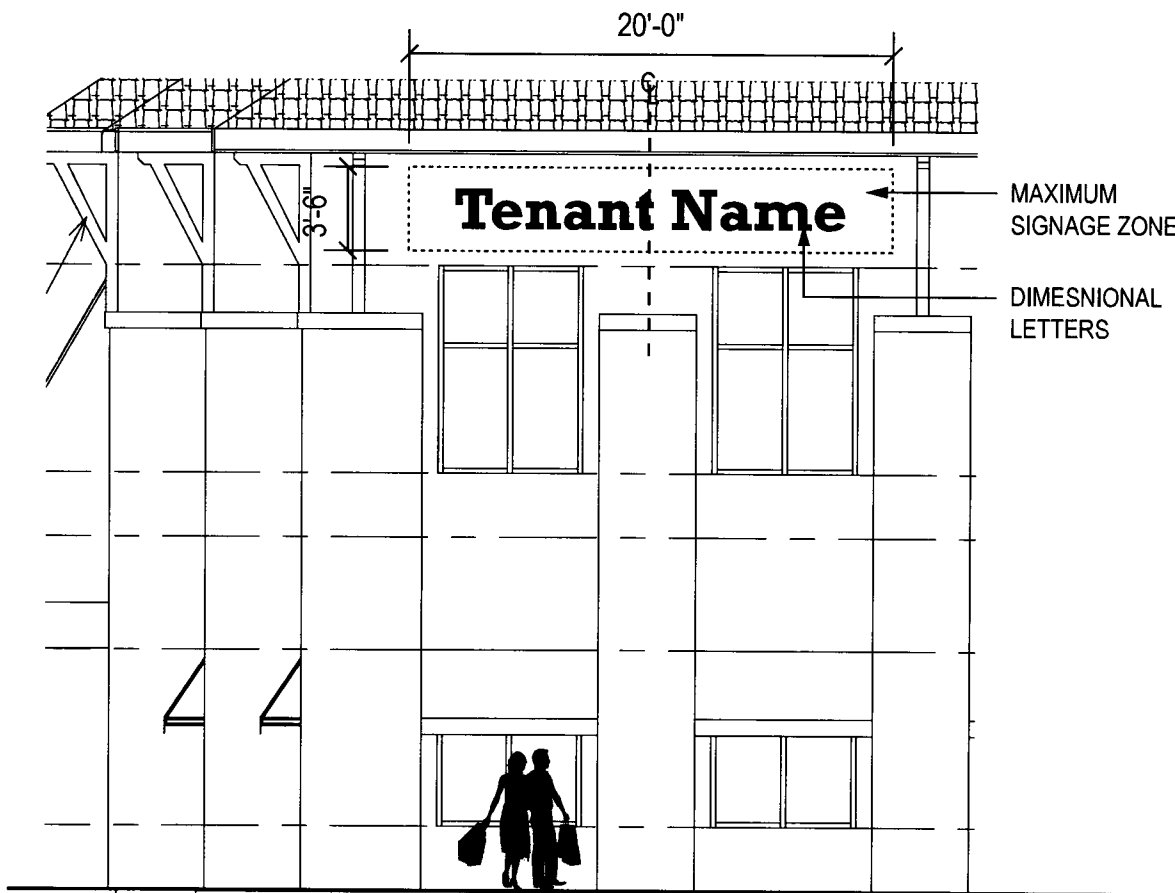

**ELEVATION: SIGN TYPE 1b - INDIVIDUAL LETTERS**

Scale: 1/8" = 1'-0"

## General Guidelines

- Tenants in storefront types C are allowed up to two (2) wall-mounted building identity sign, per Landlor approval. Tenants in storefront type A and B refer to Sign Type 1a.
- Buildings 7, 8, 9, 10 are storefront type C. Elevations for building 8 and 9 will be developed at a later date.
- Signage to remain within the zone indicated. Total sign area not to exceed 1.00 square feet per linear foot of frontage. Total length of sign not to exceed 20'-0".
- Letters to be halo-lit with 5,000 kelvin illumination. Illuminated portion to be white and rest of letter to match the project matte black color. Letters to be 3" deep and pin-mounted 1/2" to a 20'-0" x 3'-6" x 1" deep aluminum pan with spray texture to match the building's stucco finish. Said pan will be provided by tenant's signage contractor.
- All transformers are to be concealed with no visible raceways.

## Allowed

- Halo-lit illuminated channel letters.
- Tenant logotype.

## Restricted

- Tenant logomark (with Landlord approval).
- Tag Line (with Landlord approval).
- Tenant brand colors.
- Raceways.

# Sign Type 1a and 1b: Primary Building ID - Individual Letters

Sign Examples:

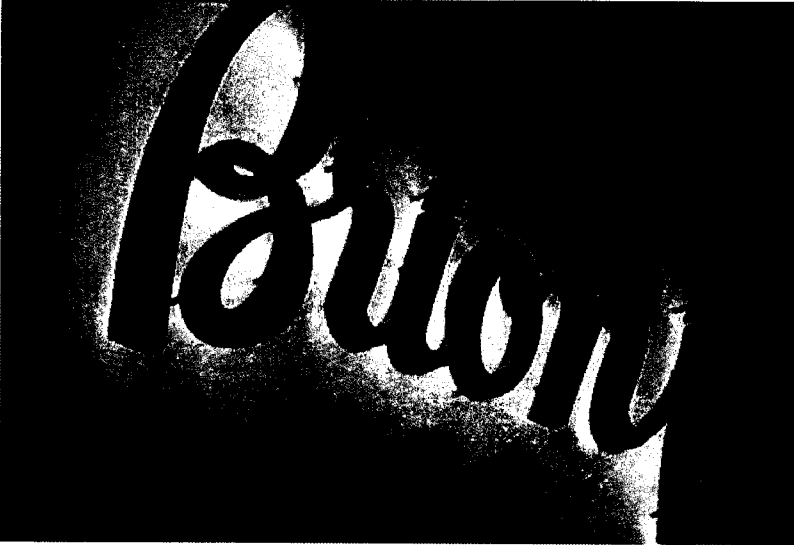

Halo illumination reference



Halo illumination reference (letters to be black)



Halo illumination reference



Halo illumination reference (letters to be black)

# Sign Type 2: Primary Building ID - Canopy Letters

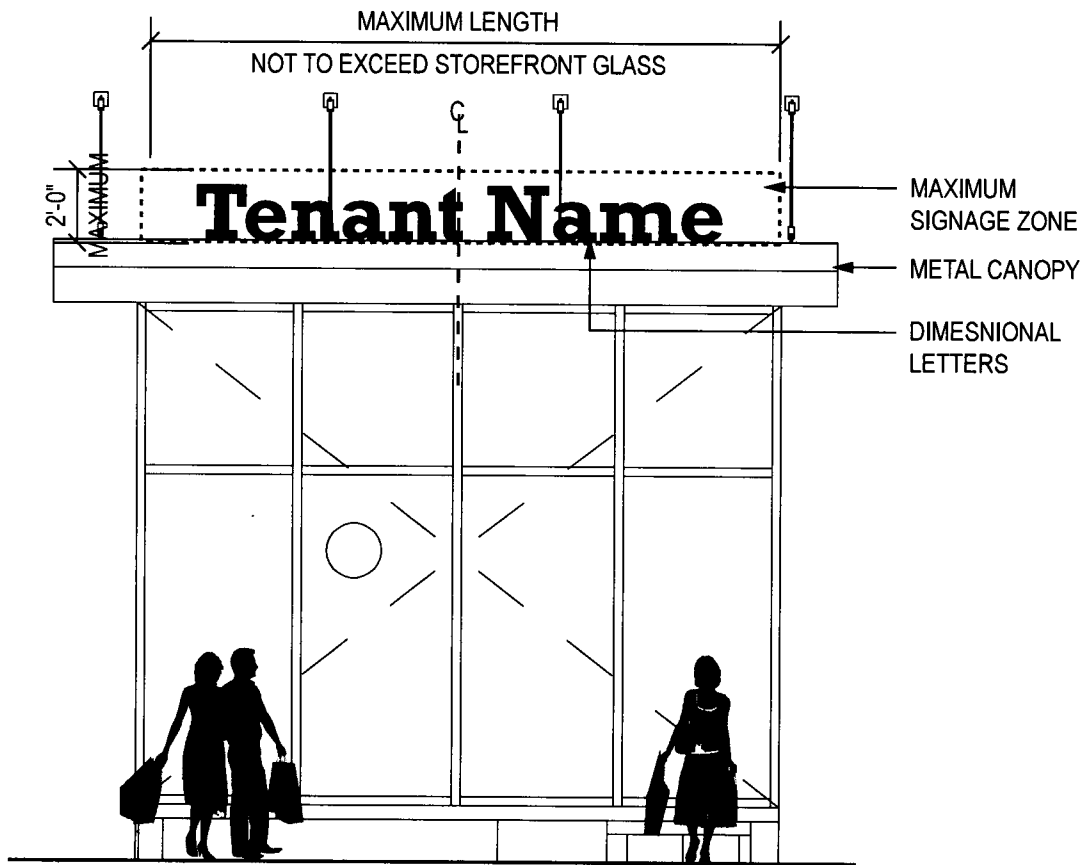

**ELEVATION: SIGN TYPE 2 - PRIMARY BUILDING ID - CANOPY LETTERS**

Scale: 3/16" = 1'-0"

## General Guidelines

- Tenants in some storefronts are allowed one (1) canopy-mounted building identity sign. Tenants with multiple facings may be allowed up to two (2) signs. If canopy letters are selected, then tenant cannot install an illuminated blade sign on the facade.
- Signage to remain within the zone indicated. Total sign area not to exceed 1.00 square feet per linear foot of frontage. Total length of sign not to exceed edges of storefront glass.
- Letters to be face-lit. Illuminated portion to be white and rest of letter to match the project matte black color. Letters to be 3" deep and use day/night vinyl on the face of the letters to illuminate white at night.
- Letters mount flush to the top edge of the canopy and are positioned to the front edge of canopy. Tenants with lower case letters with descenders (g, j, p, q, y) can mount to front edge of canopy.
- All transformers are to be concealed with no visible raceways.

## Allowed

- Internally illuminated channel letters.
- Tenant logotype.

## Restricted

- Tenant logomark (with Landlord approval).
- Tag Line.
- Tenant brand colors.
- Raceways.



# Sign Type 2: Primary Building ID - Canopy Letters

Sign Examples:

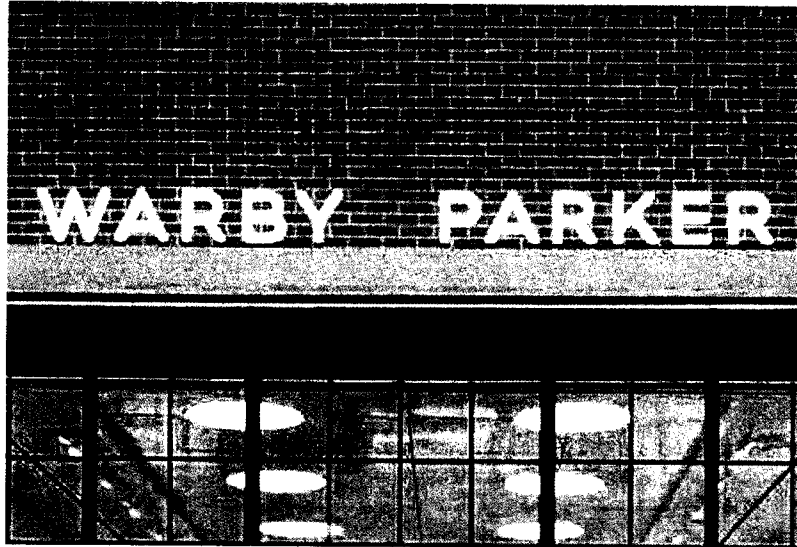

Dimensional canopy letters (returns to be black)

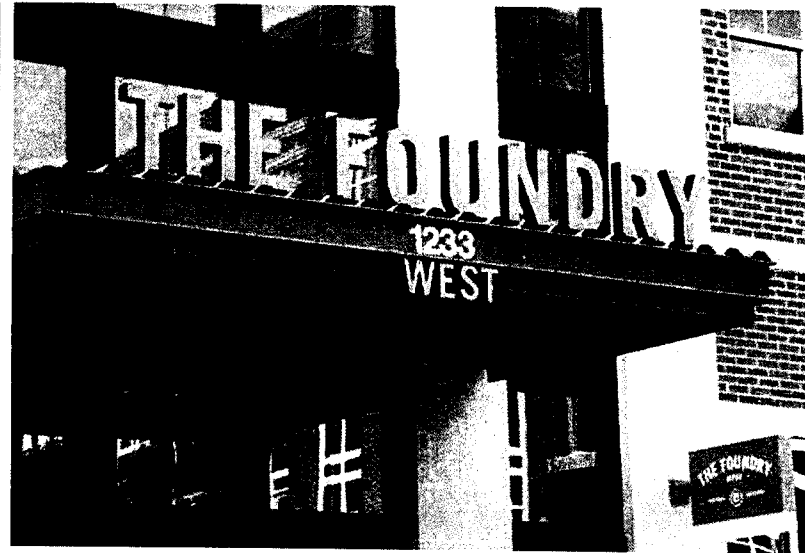

Face-lit illumination (returns to be black)

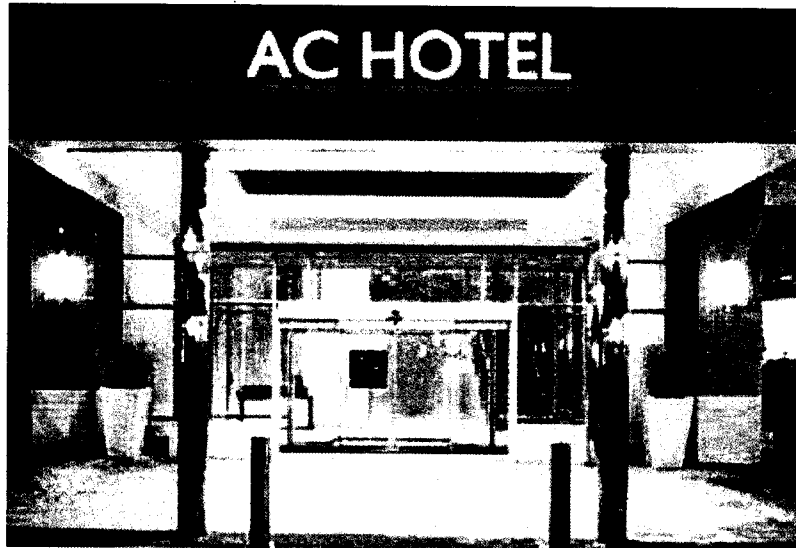

Face-lit illumination



Treatment of letters with descenders mounted to canopy edge

# Sign Type 3: Primary Building ID - Blade

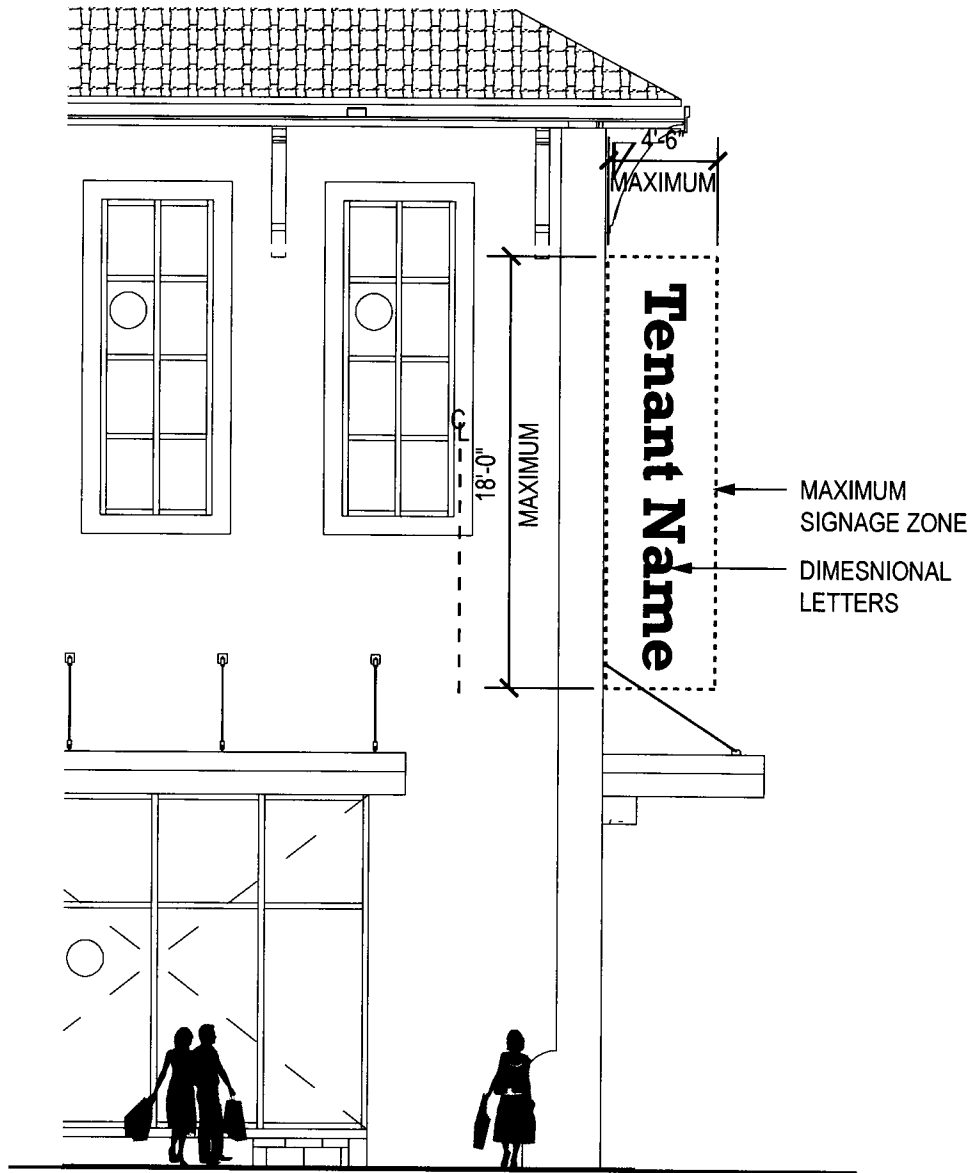

**ELEVATION: SIGN TYPE 3 - PRIMARY BUILDING ID - BLADE SIGN**

Scale: 1/8" = 1'-0"

## General Guidelines

- Tenants in some storefront type B are allowed one (1) blade-mounted building identity sign and one (1) primary building sign (sign type 1a) or two sign type 1a's and no blade-mounted sign.
- Signage to remain within the zone indicated. Total sign area not to exceed 1.00 square feet per linear foot of frontage. Total sign not to exceed 50SF.
- Blade sign panel/cabinet to be no more than 8" deep and background field, returns and mounting bracket must match the project matte black color. If illuminated, letters to be 3/4" thick white push-through letters. Non-illuminated signs have 3/8" thick dimensional white letters. Only lettering can be illuminated, not the entire cabinet.
- Signage must meet wind load requirement for the location.
- All transformers are to be concealed with no visible raceways.

## Allowed

- Internally illuminated channel letters.
- Tenant logotype.
- Tenant logo mark (with Landlord approval).

## Restricted

- Tag Line.
- Tenant brand colors.
- Raceways.

# Sign Type 3: Primary Building ID - Blade

Sign Examples:

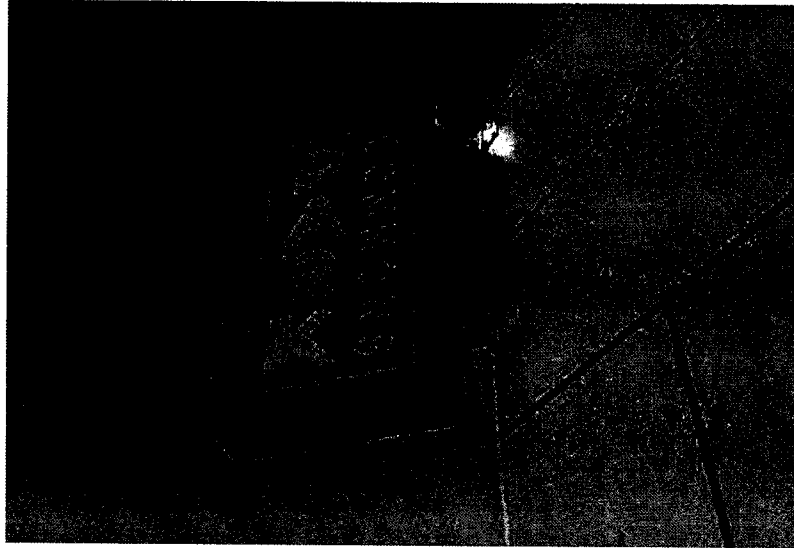

Black cabinet with white lettering

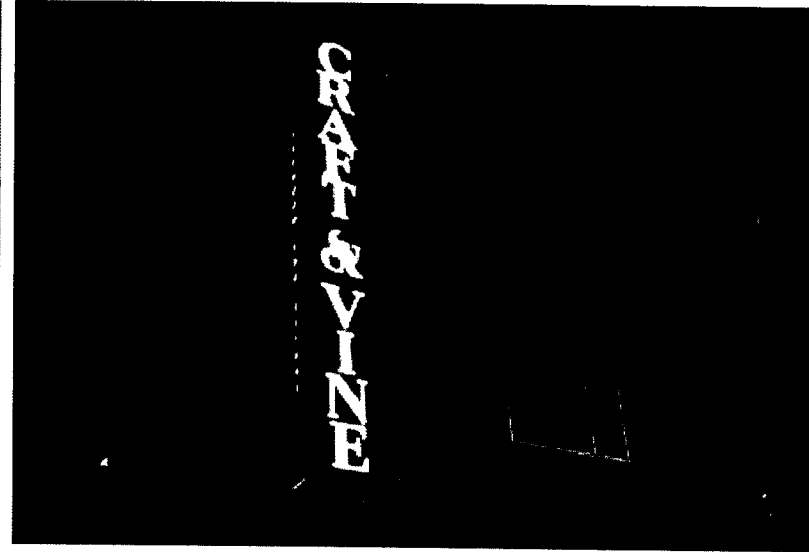

White illumination (cabinet to be black)

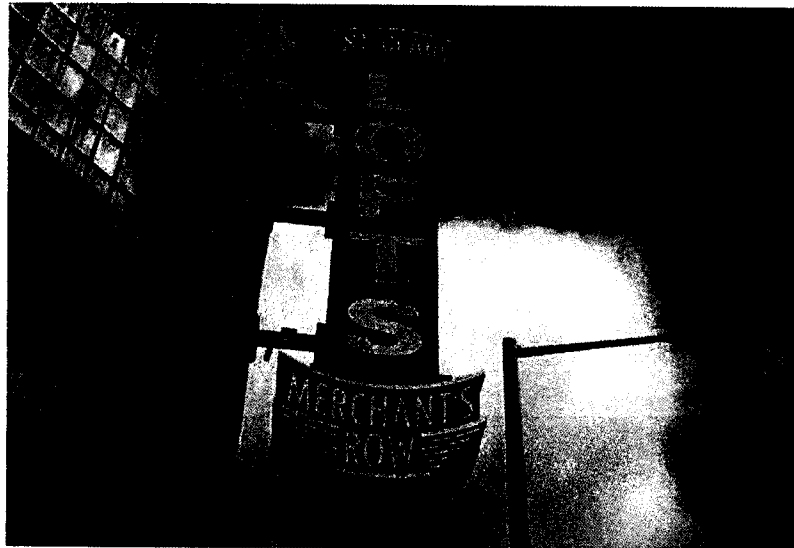

Sign shape determined by tenant

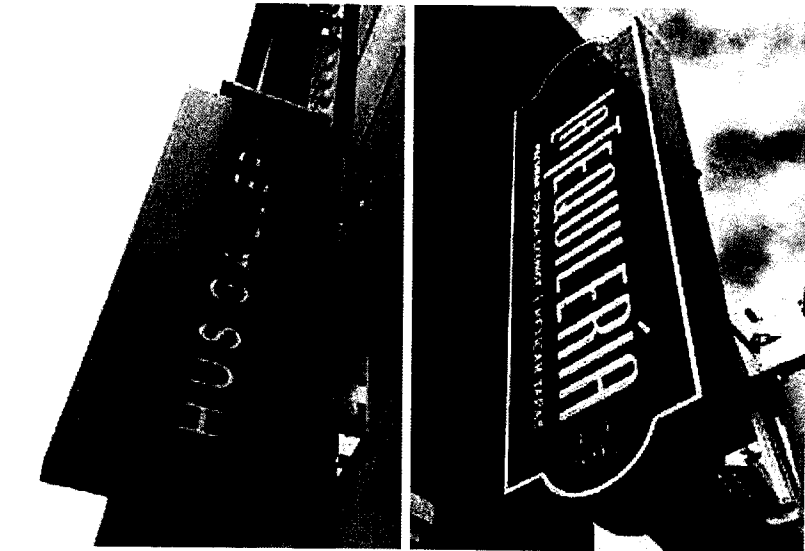

Examples of styles

# Sign Type 4: Blade Sign

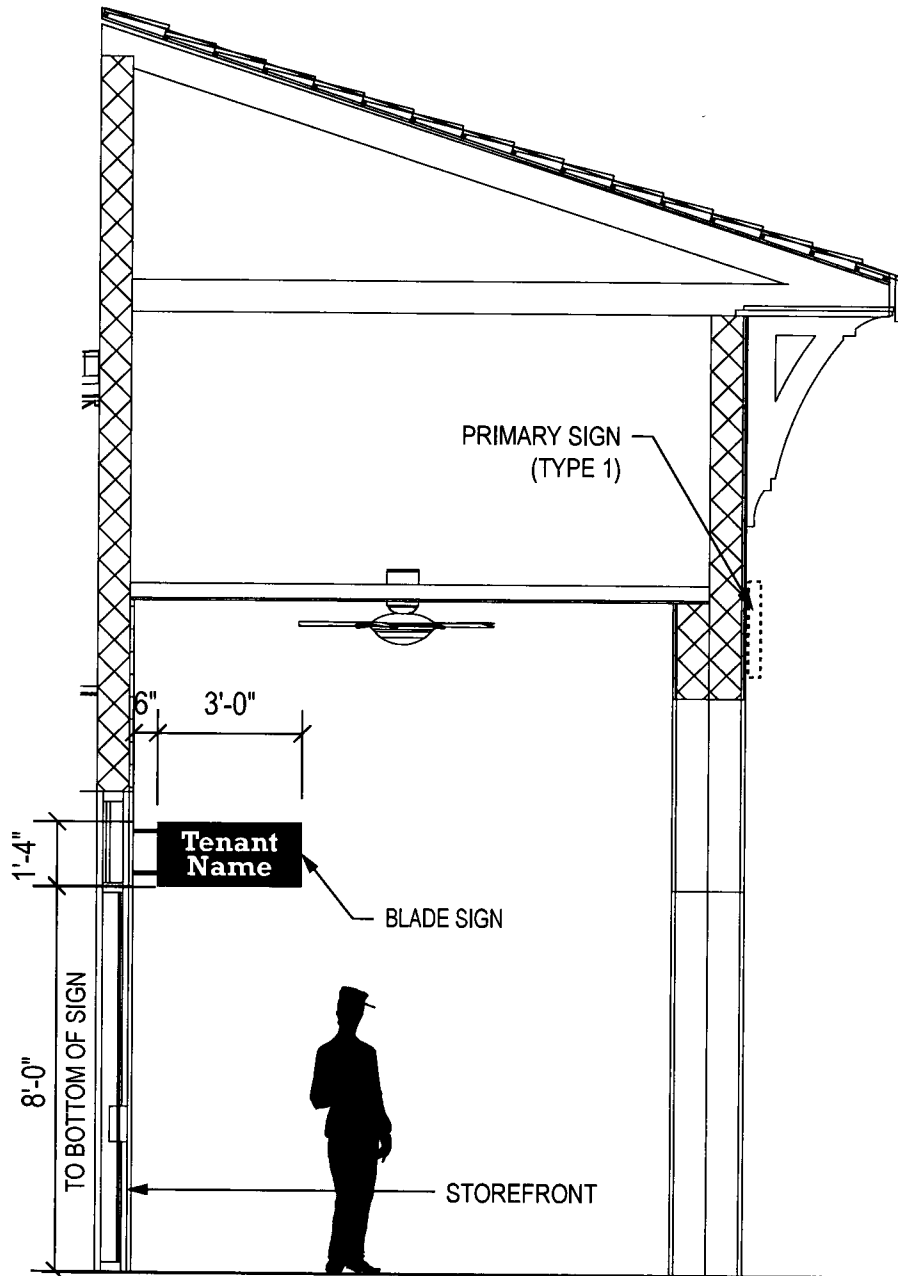

## General Guidelines:

- Tenants are allowed one (1) non-illuminated blade sign per street frontage.
- Signs attach to arcade facade to the left of tenant storefront. Signs centered on storefront unless fans cause interference.
- Maximum allowed square-footage not to exceed 4SF and must mount 8'-0" above the sidewalk.
- Sign shape can vary but is subject to landlord approval.
- Sign panel/cabinet to be no more than 3" deep and background field, returns and mounting bracket must match the project matte black color. Logotype to be 1/4" thick dimensional white letters. Letting can only be white.
- Signage must meet wind load requirement for the location.

## Allowed:

- Tenant logotype.
- Dimensional logotype.
- Tag Line (with Landlord approval).

## Restricted

- Tenant logomark (with Landlord approval).
- Tenant brand colors (with Landlord approval).

## SIGN TYPE 4 - BLADE SIGN

Scale: 1/4" = 1'-0"

# Sign Type 5: Monument Sign

## General Guidelines

- Tenants in storefront types C (buildings 7, 8, 9, 10) will be included on the building provided monument sign adjacent to the building. Exact sizes and details will be determined at a later date.
- Signage must meet wind load requirement for the location.

## Allowed

- TBD.
- Tenant logotype.

## Restricted

- Tenant logomark (with Landlord approval).
- Tag Line.
- Tenant brand colors.
- Raceways.

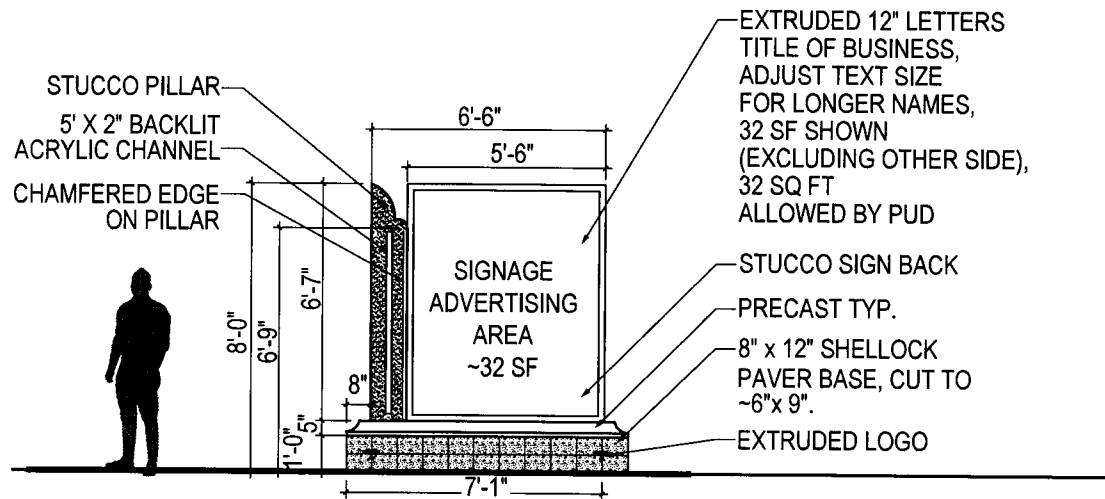

## ELEVATION: SIGN TYPE 5 - MONUMENT SIGN

Scale: 3/16" = 1'-0"

# Sign Type 6: Window Graphics

## General Guidelines:

- Tenants are allowed to have translucent white or frosted (no other color) window vinyls mounted directly to the second (inside) glass surface and intended to be read from the exterior. Window vinyls may cover up to a maximum of 35% of the total glass storefront.
- Side panels can be used for descriptive copy. All graphics are subject to landlord approval.

## Allowed (all subject to Landlord approval):

- Tenant logotype and logomark.
- Store hours.

## Prohibited:

- Brand components/patterning.
- Opaque vinyl.
- Any color other than white.
- Temporary vinyl graphics.
- Advertising messages.

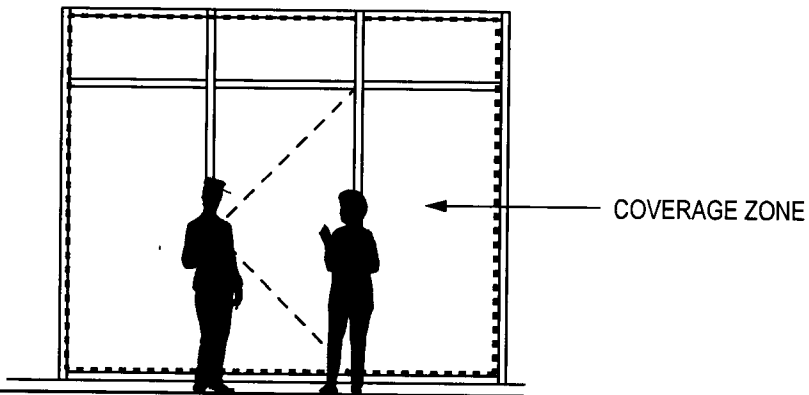

**ELEVATION: TYPICAL TENANT SPACE  
SIGN TYPE 5 - WINDOW GRAPHIC**

Scale: 3/16" = 1'-0"

