

RESOLUTION NO. 2022 - 63

A RESOLUTION BY THE BOARD OF COUNTY COMMISSIONERS OF ST. JOHNS COUNTY, FLORIDA, AUTHORIZING THE COUNTY ADMINISTRATOR, OR DESIGNEE, TO EXECUTE AND ISSUE TASK ORDER NO. 10 FOR SAWGRASS INFLUENT PUMP STATION IMPROVEMENTS TO WHARTON-SMITH, INC., UNDER RFP NO. 18-22 (MASTER CONTRACT 18-MCC-WHA-08956).

RECITALS

WHEREAS, On January 26, 2018, the County entered into agreements under RFP 18-22; Utility Rehabilitation/Construction Services, under which work is authorized by Task Orders, and requires all Task Orders in excess of \$200,000 to be approved by the Board; and

WHEREAS, the SJC Utility Department requested a proposal from Wharton-Smith, Inc., under the terms and conditions of Master Contract No: 18-MCC-WHA-08956, to provide all labor, materials, and equipment necessary for the completion of all work specified for Sawgrass Influent Pump Station Improvements, and the submitted proposal had a not-to-exceed price of \$468,562.00; and

WHEREAS, the task order will be funded through the 2022 Sawgrass Pump Station Capital Projects, Systems Improvements; and

WHEREAS, the County has reviewed the terms, provisions, conditions and requirements of the proposed task order (attached hereto, an incorporated herein) and finds that executing the task order to complete the work services serves a public purpose; and;

WHEREAS, the task order will be in substantial conformance with the attached draft task order.

NOW, THEREFORE BE IT RESOLVED BY THE BOARD OF COUNTY COMMISSIONERS OF ST. JOHNS COUNTY, FLORIDA, as follows:

Section 1. The above Recitals are incorporated by reference into the body of this Resolution and such Recitals are adopted as finds of fact.

Section 2. The County Administrator, or designee, is hereby authorized to execute a task order, in substantially the same form and format as attached, for Wharton-Smith, Inc., to complete the required work, as specifically provided in the Task Order and associated documents, at the proposed not-to-exceed amount, and in accordance with the Master Contract.

Section 3. To the extent that there are typographical and/or administrative errors that do not change the tone, tenor, or concept of this Resolution, then this Resolution may be revised without subsequent approval by the Board of County Commissioners.

PASSED AND ADOPTED by the Board of County Commissioners of St. Johns County, Florida, this 1 day of March, 2022.

**BOARD OF COUNTY COMMISSIONERS,
ST. JOHNS COUNTY, FLORIDA**

By: Henry Dean
Henry Dean, Chair

ATTEST: Brandon J. Patty
Clerk of the Circuit Court & Comptroller

By: Pam Halterman
Deputy Clerk

Rendition Date 3/3/22





St. Johns County Board of County Commissioners

Purchasing Division

CONTRACT TASK ORDER NO: 10

RFP No: 18-22; Utility Rehabilitation/Construction Services
Master Contract No: 18-MCC-WHA-08956

Contractor: Wharton-Smith, Inc
750 Monroe Road
Sanford, FL 32771

Date: February 1, 2022
Project: Sawgrass Influent Pump Station Improvements

SCOPE OF WORK:

Task Order #10 is hereby issued to authorize Wharton-Smith, Inc. ("Contractor") to provide labor, equipment, materials and supervision for the installation of influent pump station improvements at the Sawgrass WWTP located at 10047 Sawgrass Dr W, Ponte Vedra Beach, FL as proposed in the Contractor's proposal dated January 31, 2022 and Construction drawings dated January 2022, and attached hereto.

PAYMENT TERMS:

The County shall compensate the Contractor, under Task Order #10, a lump sum amount of four hundred sixty eight thousand five hundred sixty two dollars (\$468,562.00), for work satisfactorily completed in accordance with the provisions of this task order, and with the Master Contract dated January 26, 2018.

SCHEDULE:

The County shall issue a Notice to Proceed to the Contractor upon receipt of a recorded Public Construction Bond. **Work shall commence upon receipt of the Notice to Proceed and shall be completed June 30, 2022.** The Effective Date of this Task order shall be the date of signature by an authorized St. Johns County Representative. All terms and conditions of the above-referenced contract remain in full force and effect. Any work performed prior to full execution of this Task Order shall be at the Contractor's Own Risk.

Wharton-Smith, Inc.

St. Johns County, Florida

Representative
Signature:

Representative
Signature:

Printed Name
& Title:

Printed Name
& Title: Leigh A. Daniels, CPPB
Purchasing Manager

Date:

Date:

All terms and conditions of the above-referenced Master Contract dated January 26, 2018 remain in full force and effect. All invoices must reference Task Order #10. By approving this task order, the SJC Dept is certifying the availability of funds for this. Do not approve/process this task order until funds are available in the appropriate line item.

Time & Materials Task Order

Contractor:

Wharton Smith Inc.

RFP 18-22 Task Order Number:

10

ITEM NO.	DESCRIPTION	HOURLY RATE	OVERTIME RATE	HOLIDAY RATE	NORMAL HOURS	OVERTIME HOURS	HOLIDAY HOURS	TOTAL
a.	Project Manager	\$ 144	\$ 216	\$ 289	120			\$ 17,316
b.	Superintendent	\$ 141	\$ 211	\$ 282	390			\$ 54,978
c.	Foreman	\$ 67	\$ 100	\$ 133	390			\$ 25,974
d.	Equipment Operator	\$ 78	\$ 117	\$ 155				\$ -
e.	Truck Driver							\$ -
f.	Pipe Layer	\$ 56	\$ 83	\$ 111	390			\$ 21,645
g.	Skilled Laborer	\$ 46	\$ 69	\$ 93	390			\$ 18,038
h.	Unskilled Laborer	\$ 37	\$ 56	\$ 74				\$ -

ITEM NO.	DESCRIPTION	HOURLY RATE	OVERTIME RATE	HOLIDAY RATE	NORMAL HOURS	OVERTIME HOURS	HOLIDAY HOURS	TOTAL
a.	Backhoe	\$ 48	\$ 72	\$ 96	389			\$ 18,672
b.	Excavator	\$ 168	\$ 252	\$ 336	263			\$ 44,184
c.	Small Loader/Skid Steer Loader	\$ 68	\$ 102	\$ 136				\$ -
d.	Grader							\$ -
e.	Dozer	\$ 122	\$ 183	\$ 244				\$ -
f.	Dump Truck	\$ 100	\$ 150	\$ 200				\$ -
g.	Small Equipment/Tools	\$ 30	\$ 45	\$ 60				\$ -
		\$ 0				Actual:	\$ 132,339	\$ 152,190
		\$ 0				Actual:	\$ 72,362	\$ 75,980
		\$ 0				Actual:	\$ 21,148	\$ 22,206

ITEM NO.	DESCRIPTION			NUMBER OF MOBILIZATIONS	COST PER MOBILIZATION	TOTAL
a.	Regular Mobilization (~ 4-6 weeks)			1	\$ 10,000	\$ 10,000
b.	Emergency Mobilization (< 1 week)				\$ 20,000	\$ -
Sub-total						\$ 461,183

a.	Contract Performance and Payment	1.6%				\$ 7,378.92
Total						\$ 468,562

CONSTRUCTION DRAWINGS
FOR
SAWGRASS WWTP - EXISTING MASTER LIFT STATION
AND PIPING IMPROVEMENTS

PREPARED FOR:

ST. JOHNS COUNTY UTILITY DEPARTMENT

PROJECT NO 4459-56302-66046-56302
JANUARY 2022 - 100% SUBMITTAL



PROJECT LOCATION

VICINITY MAP

MM PROJECT
NO. 502100379-012

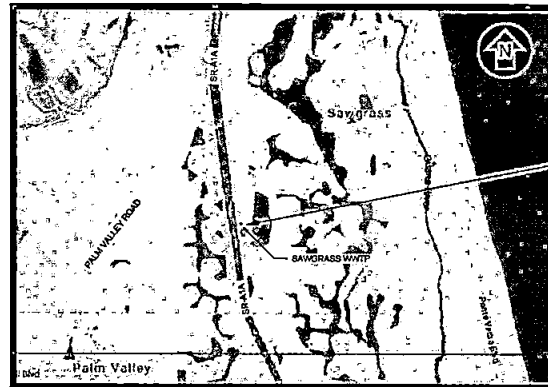

PROJECT LOCATION:
10047 SAWGRASS DRIVE WEST
PONTE VEDRA BEACH, FL 32082

LOCATION MAP

SCALE: NTS

M

M

**MOTT
MACDONALD**
Mott MacDonald Florida, LLC

Architects Engineers Surveyors
AA - C0000035 EB - 0000155 LB - 0006783
10245 Centurion Pkwy. N., Suite 320
Jacksonville, Florida 32256
Telephone: (904) 203-1090

GENERAL NOTES:

- DISTURBANCE SHALL BE LIMITED TO SLUDG PROPERTY.
- THE CONTRACTOR IS RESPONSIBLE FOR PROCURING ALL MOBILIZATION, STORAGE, AND STAGING AREAS AS WELL AS ACCESS TO THE CONSTRUCTION SITES WITHIN THE RIGHT OF WAYS, EROSION CONTROL DEVICES AND BEST MANAGEMENT PRACTICES SHALL BE INSTALLED AND MAINTAINED AT ALL WORK SITES AND STAGING AREAS. THE CONTRACTOR SHALL FOLLOW ALL LOCAL GUIDELINES AND REGULATIONS REGARDING THE WORK, INCLUDING KEEPING MUD AND DIRT OFF PUBLIC ROADS AND PRIVATE ENTRANCES.
- ANY PUBLIC LAND CORNER, PROPERTY MONUMENTATION, OR BENCH MARKS WITHIN THE LIMITS OF CONSTRUCTION SHALL BE PROTECTED. IF A MONUMENT IS IN DANGER OF BEING DESTROYED, THE CONTRACTOR SHALL NOTIFY THE ENGINEER IMMEDIATELY. ANY CORNER MONUMENT OR LANDMARKS DISTURBED OR DESTROYED SHALL BE RESET BY A PROFESSIONAL LAND SURVEYOR LICENSED IN THE STATE OF FLORIDA AT NO ADDITIONAL COST TO THE OWNER.
- FOR ALL TREN PIPING, CROSSINGS, OR VALVES THE CONTRACTOR SHALL VERIFY ALL EXISTING PIPELINE ELEVATIONS, LOCATIONS, DIAMETERS, AND MATERIALS PRIOR TO SHOP DRAWING SUBMITTALS, NOTIFYING THE ENGINEER OF ANY CONFLICTS.
- SUBMITTAL OF AS-BUILT SITE SURVEY, INCLUDING BENCH MARKS, IS REQUIRED PRIOR TO SCHEDULING FINAL INSPECTION. AS-BUILT SURVEY SHALL BE SIGNED AND SEALED BY A REGISTERED LAND SURVEYOR IN THE STATE OF FLORIDA AND SHALL INCLUDE COORDINATES OF ALL NEW STRUCTURES, ALL PIPE FITTINGS AND VALVES 2 INCH AND LARGER AND ELEVATIONS OF ALL NEW STRUCTURES AND PADS AND PIPES, VALVES AND FITTINGS 2 INCH AND LARGER.
- ELEVATIONS SHOWN HEREON ARE RELATIVE TO THE NATIONAL GEODETIC VERTICAL DATUM OF 1929 AND ARE BASED ON BENCHMARKS AS SHOWN ON THE AS-BUILT SURVEY.
- LOCATIONS, ELEVATIONS, AND DIMENSIONS OF EXISTING UTILITIES, STRUCTURES, AND OTHER FEATURES ARE SHOWN ACCORDING TO THE BEST INFORMATION AVAILABLE AT THE TIME OF PREPARATION OF THESE PLANS, BUT DO NOT PURPORT TO BE ABSOLUTELY CORRECT. PRIOR TO CONSTRUCTION, THE CONTRACTOR SHALL VERIFY AND AGREE TO BE FULLY RESPONSIBLE FOR ANY AND ALL DAMAGES WHICH MIGHT BE OCCASIONED BY HIS FAILURE TO EXACTLY LOCATE FEATURES AFFECTING HIS WORK.
- PRIOR TO BEGINNING CONSTRUCTION, THE CONTRACTOR SHALL PHYSICALLY VERIFY LOCATION OF ALL UTILITIES, ABOVE AND BELOW GROUND AND NOTIFY SLUDG 72 HOURS PRIOR TO DIGGING IN ANY PORTION OF THE SITE.
- THE CONTRACTOR SHALL CONTACT THE ENGINEER'S OFFICE IMMEDIATELY UPON FINDING ANY CONFLICTS DURING CONSTRUCTION ON ANY IMPROVEMENTS SHOWN ON THE DRAWINGS.
- THE CONTRACTOR SHALL NOTE ALL EXISTING UTILITIES ENCOUNTERED DURING EXCAVATION AND INCLUDE ON AS-BUILT DRAWINGS.
- THE CONTRACTOR SHALL, BY REPAIR OR REPLACEMENT, RETURN TO EQUAL OR BETTER CONDITION ALL PAVEMENT, SIDEWALK, LAWNS, UTILITIES AND OTHER ITEMS DAMAGED BY THE CONSTRUCTION ACTIVITY.
- ALL BRUSH, STRIPPING OR UNSUITABLE MATERIAL SHALL BE DISPOSED OF OFF-SITE AT THE CONTRACTOR'S EXPENSE.
- NO REPRESENTATION IS MADE REGARDING BALANCED EARTHWORK. ANY EXCESS MATERIAL, OR MATERIAL NOT SUITABLE FOR USE AS BACKFILL SHALL BE HAULED AWAY TO AN APPROVED DISPOSAL AT THE CONTRACTOR'S EXPENSE, AND WHERE NECESSARY, SUITABLE FILL AND BACKFILL SHALL BE PROVIDED AND NO ADDITIONAL COMPENSATION SHALL BE ALLOWED.
- CONTRACTOR SHALL PERFORM IN THE PRESENCE OF SLUDG AND THE ENGINEER A PRE-CONSTRUCTION VIDEO DOCUMENTING EXISTING CONDITIONS.
- ALL BURIED PIPING SHALL BE OF THE RESTRAINED JOINT TYPE.

UTILITY CONTACTS:

A. AT&T - GENERAL NUMBER	904-519-2329
B. AT&T - ADAM BUSHAW - NORTH DISTRICT	904-781-0741
C. AT&T - BILL LAKE - SOUTH DISTRICT	904-303-8754
D. FLORIDA DEPT. OF TRANSPORTATION	904-369-8200
E. ST. JOHNS COUNTY - RIGHT-OF-WAY PERMITTING - RICK MAULDEN	904-200-1134
F. ST. JOHNS COUNTY - TRAFFIC SIGNALS - HANK MEN	904-200-0173
G. COMCAST - EMERGENCY HOTLINE	904-390-4274
H. TECOPEOPLE GAS - BEN MOBLEY	904-645-9059
I. SUNSHINE ONE CALL	811
J. BEACHES ENERGY SERVICES - ROBERT ALP	904-247-4252

INDEX OF DRAWINGS:

INDEX		
SHEET NO.	DWG. NO.	TITLE
-	-	COVER
1	G-1	GENERAL NOTES AND SHEET INDEX
2	G-2	ABBREVIATIONS AND SYMBOLS
3	C-1	EXISTING SITE PLAN
4	C-2	PROPOSED SITE PLAN AND YARD PIPING PLAN
5	CD-1	STORMWATER AND EROSION CONTROL DETAILS
6	CD-2	CIVIL DETAILS
7	S-1	STANDBY DIESEL PUMP PAD AND MISCELLANEOUS PADS
8	M-1	MASTER LIFT STATION IMPROVEMENTS PLAN MODIFICATIONS
9	M-2	MASTER LIFT STATION IMPROVEMENTS SECTIONS AND DETAILS
10	M-3	STANDBY DIESEL PUMP PLAN AND SECTIONS
11	MD-1	MECHANICAL DETAILS
12	E-1	ELECTRICAL LEGEND AND SCHEDULES
13	E-2	INSTRUMENTATION & CONTROL SCHEMATIC DIAGRAM
14	E-3	INSTRUMENTATION & CONTROL DETAILS
15	E-4	ELECTRICAL SITE PLAN
16	E-5	MASTER LIFT STATION ELECTRICAL PLAN
17	E-6	IN-PLANT DRAIN PS DEMOLITION ELECTRICAL PLAN
18	ED-1	ELECTRICAL DETAILS

File Jan 07, 2022 - 11:22

C:\Users\jacob1\OneDrive\Documents\Drawings\Current Layout\Tab - Layout 1 - Sawgrass WWT - Existing.dwg

<table border="1"> <tr> <th>NO.</th> <th>BY</th> <th>DATE</th> <th>REVISED</th> </tr> <tr> <td> </td> <td> </td> <td> </td> <td> </td> </tr> </table>	NO.	BY	DATE	REVISED					<p>M&M MacDonnell Florida, LLC</p>	<p>Architects Engineers Surveyors AA - C0000035 EB - 00001155 LB - 0008783 10245 Centurion Pkwy, N., Suite 320 Jacksonville, Florida 32256 Telephone: (904) 233-1090</p>	<table border="1"> <tr> <td>DESIGNER</td> <td>J. TRACY</td> </tr> <tr> <td>DRAWN BY</td> <td>D. JACOBS</td> </tr> <tr> <td>DATE</td> <td>JAN 2022</td> </tr> <tr> <td>CHECKED BY</td> <td>L. SAMEL</td> </tr> <tr> <td>DATE</td> <td>JAN 2022</td> </tr> </table>	DESIGNER	J. TRACY	DRAWN BY	D. JACOBS	DATE	JAN 2022	CHECKED BY	L. SAMEL	DATE	JAN 2022	<table border="1"> <tr> <td>DESIGN ENGINEER</td> <td>LESLIE S. SAMEL, P.E.</td> </tr> <tr> <td>FLORIDA REGISTRATION NO.</td> <td>69763</td> </tr> </table>	DESIGN ENGINEER	LESLIE S. SAMEL, P.E.	FLORIDA REGISTRATION NO.	69763	<p>St. Johns County Utility Department 1206 STATE ROAD 16 ST. AUGUSTINE, FL 32084 PHONE: (904) 200-3029 FAX: (904) 200-2627</p>	<p>SAWGRASS WWT - EXISTING MASTER LIFT STATION AND PIPING IMPROVEMENTS</p>	<p>GENERAL NOTES AND SHEET INDEX</p>	<table border="1"> <tr> <td>SHEET NO.</td> <td>1</td> </tr> <tr> <td>DWG. NO.</td> <td>G-1</td> </tr> <tr> <td>100% SUBMITTAL</td> <td> </td> </tr> </table>	SHEET NO.	1	DWG. NO.	G-1	100% SUBMITTAL	
NO.	BY	DATE	REVISED																																	
DESIGNER	J. TRACY																																			
DRAWN BY	D. JACOBS																																			
DATE	JAN 2022																																			
CHECKED BY	L. SAMEL																																			
DATE	JAN 2022																																			
DESIGN ENGINEER	LESLIE S. SAMEL, P.E.																																			
FLORIDA REGISTRATION NO.	69763																																			
SHEET NO.	1																																			
DWG. NO.	G-1																																			
100% SUBMITTAL																																				

ABBREVIATIONS

GENERAL

Table of abbreviations for general symbols, including terms like ABANDONED, ADJUSTMENT, ALLEY GRATE, AIR RELEASE VALVE, BURIED ELECTRICAL, BASE LINE, BIODIGESTER, BENCHMARK, BOTTOM OF CURVE, CATCH BASIN, CAST IRON, CENTERLINE, CITY ELECTRIC POLE, CEMENT LINED DUCTILE IRON, CONCRETE, CONSTRUCTION, CORRUGATED METAL PIPE, CORRODED METAL PIPE ARCH, CULVERT, CURB & GUTTER, CATCH BOTTOM INVERT, DIMENSION LINES, DRIVEWAY, EDGE OF PAVEMENT, ELECTRICAL, ELEVATION, ELLIPTICAL REINFORCED CONC. PIPE, EXPANSION JOINT, FIRE HYDRANT, FLOW LINE, FURNACE, FIBER OPTIC, GALVANIZED, GATE VALVE, GROUND STORAGE TANK, HIGH DENSITY POLYETHYLENE PIPE, HEAD WALL, HIGH CURB.

PROCESS FLOW STREAMS

Table of process flow stream abbreviations, including terms like DRAIN, DIESEL FUEL, EXHAUST, FOLL AIR DUCT, FILTER EFFLUENT, CHEMICAL FILL LINE, FORCE MAIN, FRESH WATER, INFLUENT FORCE MAIN, MIXED LIQUID SUSPENDED SOLIDS INFLUENT, OVERFLOW, PLANT EFFLUENT, PLANT WATER, POTABLE WATER, RETURN ACTIVATED SLUDGE, RECLAIMED WATER MAIN, SUPPLEMENTAL AIR, SANITARY SEWER, SPILLER BOX INFLUENT, SECONDARY CLARIFIER DRAIN, SECONDARY CLARIFIER INFLUENT, SCUM HYPOCHLORITE, SAMPLE LINE, SLUDGE TRANSFER PUMP DISCHARGE, SUCTION, STORM WATER, VENT, WASTE ACTIVATED SLUDGE, WATER MAIN.

PIPE MATERIALS

Table of pipe materials abbreviations, including terms like CAST IRON, CHLORINATED POLYVINYL CHLORIDE, DUCTILE IRON, FIBERGLASS REINFORCED PLASTIC, GALVANIZED STEEL, HIGH DENSITY POLYETHYLENE, PRESTRESSED CONCRETE CYLINDER PIPE, POLYVINYL CHLORIDE, REINFORCED CONCRETE, RUBBER, SST OR SS STAINLESS STEEL.

PIPE JOINTS

Table of pipe joints abbreviations, including terms like BLIND FLANGE, FLANGE, PLAIN END, MECHANICAL, RESTRAINED, THREADED.

LANDSCAPE AND DRAINAGE SYMBOLS

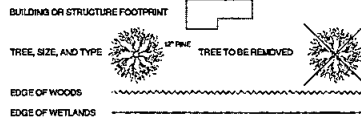

BOUNDARY AND MARKER SYMBOLS

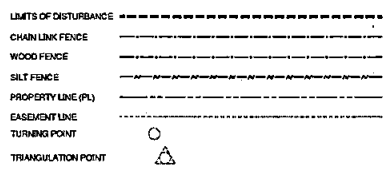

PIPE AND FITTING SYMBOLS

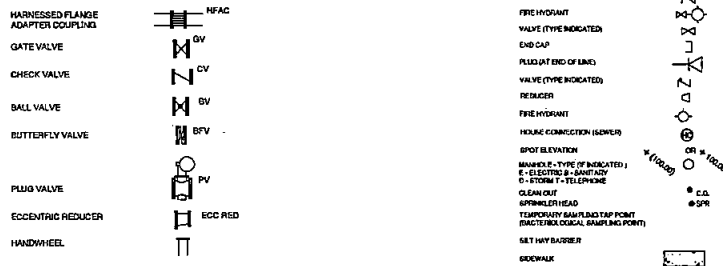

DETAIL CALL OUT

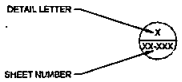

GENERAL LEGEND

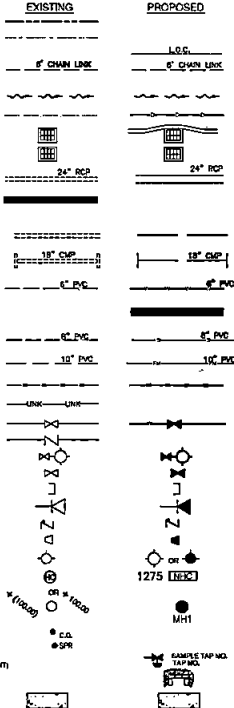

UTILITY SYMBOLS

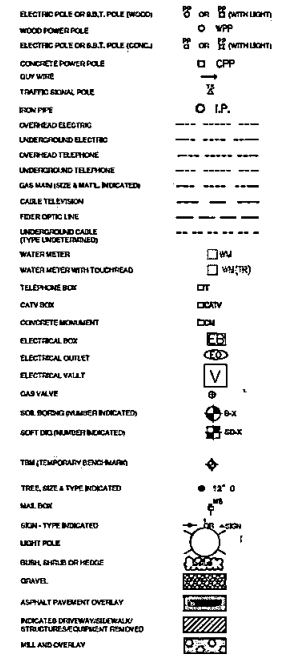

Plot Date: 07/2023 - 12:23
Current Layout Tab = 0-2
C:\Users\jquinn\OneDrive\Documents\10833330\0-2.dwg
Note Attachments: S:\D_2134_BSR [L:\08333330\0-2.dwg] [S:\D_2134_BSR.dwg]

Project information table including: NO. BY DATE BYAPPD, REVISIONS, M M NOT RECORDED, Architects Engineers Surveyors AA-C0000035 EB-0000155 LB-0008783, DESIGNER L. TRACEY, DESIGN ENGINEER LESLIE S. SAMEL, P.E., St. Johns County Utility Department, 1205 STATE ROAD 18, ST. AUGUSTINE, FL 32084, PHONE: (904) 200-2629 FAX: (904) 200-2027, SAWGRASS WWTP - EXISTING MASTER LIFT STATION AND PIPING IMPROVEMENTS, ABBREVIATIONS AND SYMBOLS, SHEET NO. 0-2, 100% SUBMITTAL

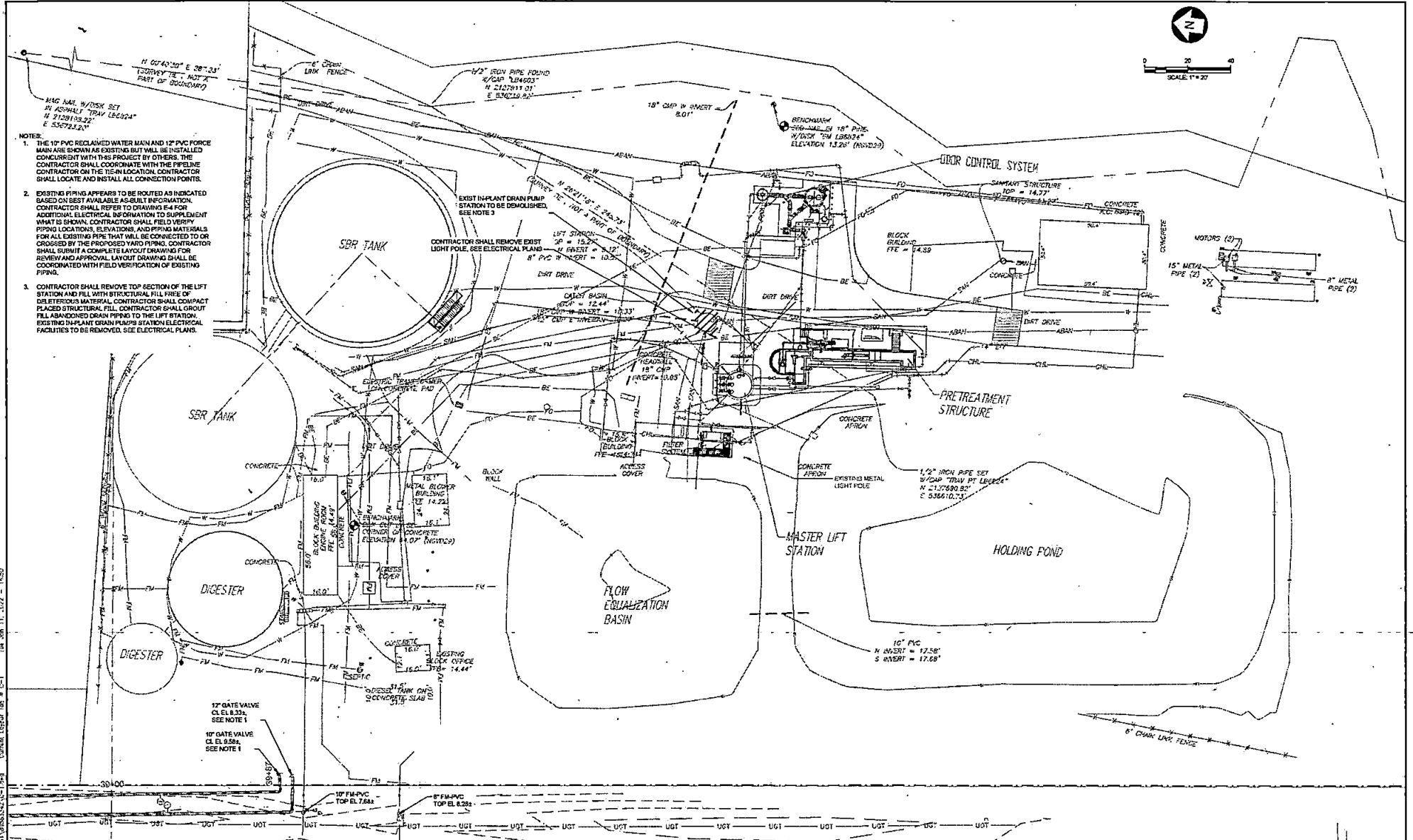

- NOTES:**
- THE 10" PVC RECLAIMED WATER MAIN AND 12" PVC FORCE MAIN ARE SHOWN AS EXISTING BUT WILL BE INSTALLED CONCURRENT WITH THIS PROJECT BY OTHERS. THE CONTRACTOR SHALL COORDINATE WITH THE PIPELINE CONTRACTOR ON THE TIE-IN LOCATION. CONTRACTOR SHALL LOCATE AND INSTALL ALL CONNECTION POINTS.
 - EXISTING PIPING APPEARS TO BE ROUTED AS INDICATED BASED ON BEST AVAILABLE AS-BUILT INFORMATION. CONTRACTOR SHALL REFER TO DRAWING EA FOR ADDITIONAL ELECTRICAL INFORMATION TO SUPPLEMENT WHAT IS SHOWN. CONTRACTOR SHALL FIELD VERIFY PIPING LOCATIONS, ELEVATIONS, AND PIPING MATERIALS FOR ALL EXISTING PIPE THAT WILL BE CONNECTED TO OR CROSSED BY THE PROPOSED YARD PIPING. CONTRACTOR SHALL SUBMIT A COMPLETE LAYOUT DRAWING FOR REVIEW AND APPROVAL. LAYOUT DRAWING SHALL BE COORDINATED WITH FIELD VERIFICATION OF EXISTING PIPING.
 - CONTRACTOR SHALL REMOVE TOP SECTION OF THE LIFT STATION AND FILL WITH STRUCTURAL FILL FREE OF DELETERIOUS MATERIAL. CONTRACTOR SHALL CONSTRUCT PLACED STRUCTURAL FILL. CONTRACTOR SHALL GROUT FILL ABANDONED DRAIN PIPING TO THE LIFT STATION. EXISTING IN-PLANT DRAIN PUMP STATION ELECTRICAL FACILITIES TO BE REMOVED. SEE ELECTRICAL PLANS.

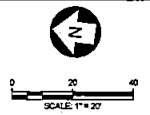

C:\Users\jacob\OneDrive\Documents\105-00-11-1022 - 1050
 105-00-11-1022 - 1050
 Current Topog 105-00-1

NO.	BY	DATE	REVISION	M M MOE MacDONALD MOE MacDONALD Florida, LLC	Architects Engineers Surveyors AA - C0000033 EB - 0000155 LB - 0008783 10245 Cavallaro Pkwy, N. Suite 320 Jacksonville, Florida 32256 Telephone: (904) 203-1090	DESIGNER L. TRACY	DESIGN ENGINEER LESLIE S. SAMEL, P.E. FLORIDA REGISTRATION NO. 68783	 St. Johns County Utility Department 1205 STATE ROAD 16 ST. AUGUSTINE, FL 32084 PHONE: (904) 200-2630 FAX: (904) 200-2027	SAWGRASS WWTP - EXISTING MASTER LIFT STATION AND PIPING IMPROVEMENTS	EXISTING SITE PLAN	SHEET NO. # DRAWING C-1 1/100% SUBMITTAL
						DRAWN BY B. JACOBS					

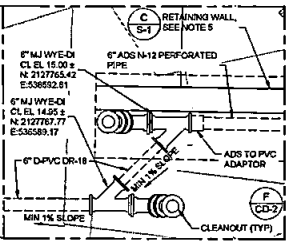
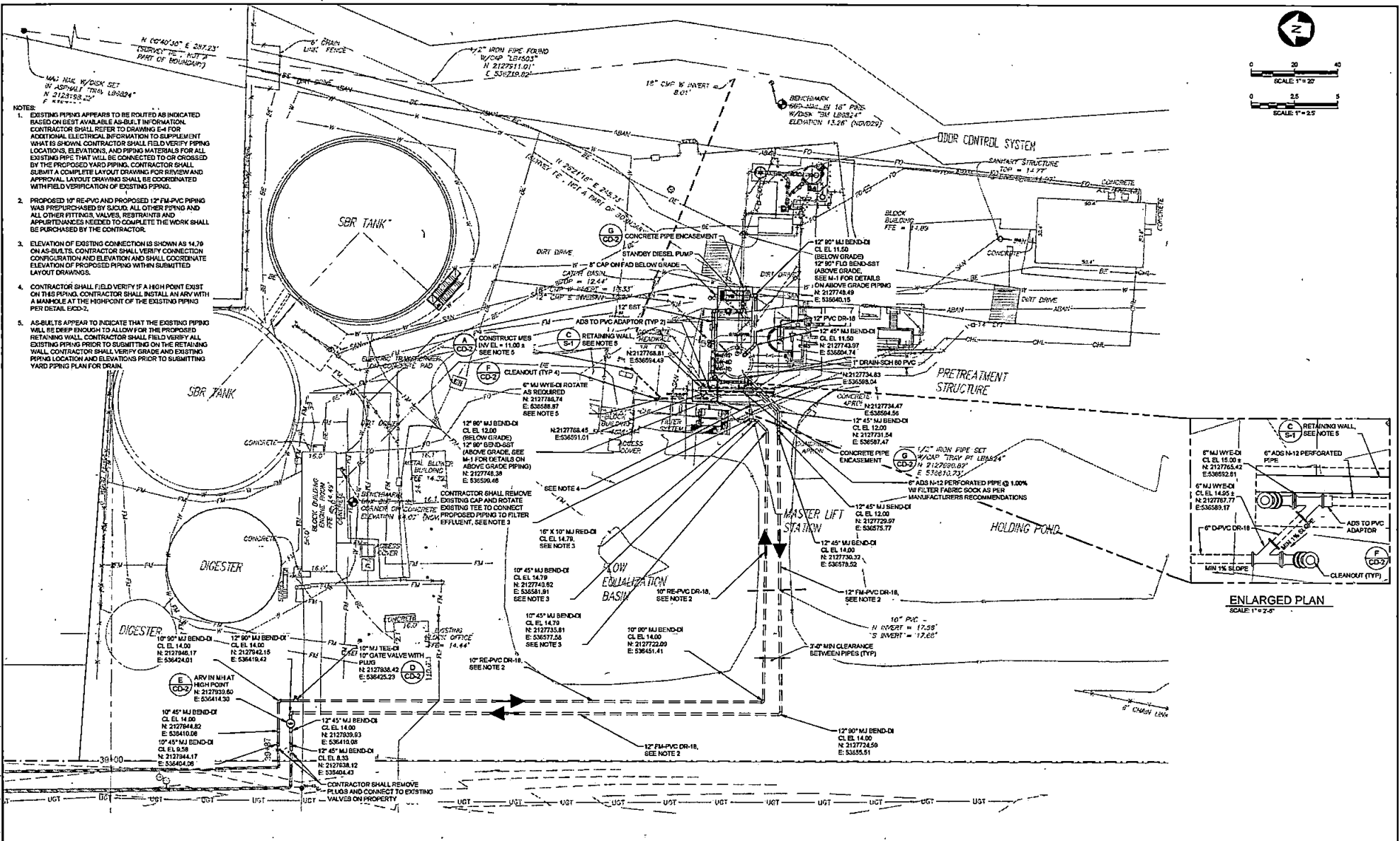
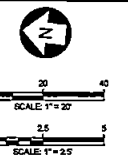

ENLARGED PLAN
SCALE: 1" = 2'-0"

- NOTES:**
- EXISTING PIPING APPEARS TO BE ROUTED AS INDICATED BASED ON BEST AVAILABLE AS-BUILT INFORMATION. CONTRACTOR SHALL REFER TO DRAWING E-4 FOR ADDITIONAL ELECTRICAL INFORMATION TO SUPPLEMENT WHAT IS SHOWN. CONTRACTOR SHALL FIELD VERIFY PIPING LOCATIONS, ELEVATIONS, AND PIPING MATERIALS FOR ALL EXISTING PIPE THAT WILL BE CONNECTED TO OR CROSSED BY THE PROPOSED YARD PIPING. CONTRACTOR SHALL SUBMIT A COMPLETE LAYOUT DRAWING FOR REVIEW AND APPROVAL. LAYOUT DRAWINGS SHALL BE COORDINATED WITH FIELD VERIFICATION OF EXISTING PIPING.
 - PROPOSED 10" RE-PVC AND PROPOSED 12" FM-PVC PIPING WAS PREPURCHASED BY SUCO. ALL OTHER PIPING AND ALL OTHER FITTINGS, VALVES, RESTRAINTS AND APPURTENANCES NEEDED TO COMPLETE THE WORK SHALL BE PURCHASED BY THE CONTRACTOR.
 - ELEVATION OF EXISTING CONNECTION IS SHOWN AS 14.70 ON AS-BUILTS. CONTRACTOR SHALL VERIFY CONNECTION CONFIGURATION AND ELEVATION AND SHALL COORDINATE ELEVATION OF PROPOSED PIPING WITHIN SUBMITTED LAYOUT DRAWINGS.
 - CONTRACTOR SHALL FIELD VERIFY IF A HIGH POINT EXISTS ON THIS PIPING. CONTRACTOR SHALL INSTALL AN ARV WITH A HANDLE AT THE HIGHEST POINT OF THE EXISTING PIPING PER DETAIL EAD-2.
 - AS-BUILTS APPEAR TO INDICATE THAT THE EXISTING PIPING WILL BE DEEP ENOUGH TO ALLOW FOR THE PROPOSED RETAINING WALL. CONTRACTOR SHALL FIELD VERIFY ALL EXISTING PIPING PRIOR TO SUBMITTING ON THE RETAINING WALL. CONTRACTOR SHALL VERIFY GRADE AND EXISTING PIPING LOCATION AND ELEVATIONS PRIOR TO SUBMITTING YARD PIPING PLAN FOR DRAW.

Thu Jan 13, 2022 - 10:52
 Current layout Top = C-2

NO.	BY	DATE	SYMBOL	REVISIONS
1				
2				
3				
4				
5				

	Architects Engineers Surveyors	DESIGNER: L. TRACY	DESIGN ENGINEER
	AA - C0000203 EB - 0000155 LB - 0000783	DRAWN BY: D. JACOBS	LESLIE S. SAMEL, P.E.
	1045 Cantonment Pkwy., N. Suite 320	DATE: JAN 2022	FLORIDA REGISTRATION NO.
	Jacksonville, Florida 32256	CHECKED BY: L. SAMEL	68763
	Telephone: (904) 203-1000	DATE: JAN 2022	

	St. Johns County	SAWGRASS WWTP - EXISTING MASTER LIFT STATION AND PIPING IMPROVEMENTS	PROPOSED SITE PLAN AND YARD PIPING PLAN
	Utility Department		
	1205 STATE ROAD 10		
	87, AUGUSTINE, FL 32094		
	PHONE: (904) 200-2025 FAX: (904) 200-2027		

SHEET NO. 9
DWG. NO. C-2
100% PLAN/SECTION

- GENERAL NOTES FOR SOIL EROSION AND SEDIMENT CONTROL:**
1. ALL EROSION AND SEDIMENT CONTROL PRACTICES TO BE INSTALLED PRIOR TO ANY MAJOR SOIL DISTURBANCE, OR IN THEIR PROPER SEQUENCE, AND MAINTAINED UNTIL PERMANENT PROTECTION IS ESTABLISHED.
 2. ANY DISTURBED AREAS THAT WILL BE LEFT EXPOSED MORE THAN 30 DAYS, AND NOT SUBJECT TO CONSTRUCTION TRAFFIC, WILL IMMEDIATELY RECEIVE A TEMPORARY SEEDING. IF THE SEASON PREVENTS THE ESTABLISHMENT OF A TEMPORARY SEEDING, THE DISTURBED AREAS WILL BE MULCHED WITH STRAW OR EQUIVALENT MATERIAL, AT A RATE OF TWO (2) TONS PER ACRE, ACCORDING TO STATE STANDARDS.
 3. PERMANENT VEGETATION TO BE SEEDING OR SOODED ON ALL EXPOSED AREAS WITHIN TEN (10) DAYS AFTER GRADING. MULCH TO BE USED AS NECESSARY FOR PROTECTION UNTIL SEEDING IS ESTABLISHED.
 4. ALL WORK AND MATERIALS TO BE IN ACCORDANCE WITH THE MOST STANDARD SPECIFICATIONS FOR ROAD AND BRIDGE CONSTRUCTION, LATEST EDITION, SECTIONS 104, 870, AND 937 TO 937.
 5. A BITUMINOUS CONCRETE BASE COURSE WILL BE APPLIED IMMEDIATELY FOLLOWING ROUGH GRADING AND INSTALLATION OF IMPROVEMENTS IN ORDER TO STABILIZE STREETS, ROADS, DRIVEWAYS AND PARKING AREAS. IN AREAS WHERE NO UTILITIES ARE PRESENT, THE BITUMINOUS CONCRETE BASE SHALL BE INSTALLED WITHIN 15 DAYS OF THE PRELIMINARY GRADING.
 6. IMMEDIATELY FOLLOWING INITIAL DISTURBANCE OR ROUGH GRADING, ALL CRITICAL AREAS SUBJECT TO EROSION (I.E. STEEP SLOPES AND ROADWAY EXCAVATIONS) WILL RECEIVE A TEMPORARY SEEDING IN COMBINATION WITH STRAW MULCH OR A SUITABLE EQUIVALENT, AT A RATES OF TWO (2) TO FOUR (4) TONS MOVED WITH THE TOP TWO (2) INCHES OF SOIL, ACCORDING TO STATE STANDARDS.
 7. ANY STEEP SLOPES RECEIVING PIPELINE INSTALLATION WILL BE BACKFILLED AND STABILIZED DAILY, AS THE INSTALLATION PROCEEDS (I.E. SLOPES GREATER THAN 3:1).
 8. UNFILTERED DEWATERING IS NOT PERMITTED. THE CONTRACTOR SHALL TAKE ALL NECESSARY PRECAUTIONS DURING ALL Dewatering OPERATIONS TO MINIMIZE SEDIMENT TRANSPORT.
 9. SHOULD THE CONTROL OF DUST AT THE SITE BE NECESSARY, THE SITE WILL BE SPRINKLED UNTIL THE SURFACE IS WET. TEMPORARY VEGETATION COVER SHALL BE ESTABLISHED OR MULCH SHALL BE APPLIED IN ACCORDANCE WITH STATE STANDARDS FOR EROSION CONTROL.
 10. ALL SOIL WASHED, DRIPPED, SPILLED OR TRACKED OUTSIDE THE LIMIT OF DISTURBANCE OR ONTO PUBLIC RIGHTS-OF-WAY WILL BE REMOVED IMMEDIATELY.
 11. ALL SOIL STOCKPILES ARE TO BE TEMPORARILY STABILIZED IN ACCORDANCE WITH SOIL EROSION AND SEDIMENT CONTROL NOTE NUMBER 2 (ABOVE).
 12. ALL SEDIMENTATION STRUCTURES SHALL BE INSPECTED AND MAINTAINED REGULARLY.
 13. THE CONTRACTOR SHALL PREPARE A PLAN FOR THE PROPER DEWATERING AND DOWNSTREAM SEDIMENT PROTECTION OF EACH STREAM CROSSING PRIOR TO DEWATERING THE STREAM BED. PLAN SHALL BE FORWARDED TO THE ENGINEER FOR APPROVAL. THE ENGINEER SHALL BE NOTIFIED FOR INSPECTION PRIOR TO EACH STREAM CROSSING CONSTRUCTION.
 14. ANY AREAS USED FOR THE CONTRACTOR'S STAGING, INCLUDING BUT NOT LIMITED TO, TEMPORARY STORAGE OF STOCKPILED MATERIALS (I.E. CRUSHED STONE, QUARRY PROCESS STONE, SELECT FILL, EXCAVATED MATERIALS, ETC.), SHALL BE ENTIRELY PROTECTED BY A SILT FENCE ALONG THE LOW ELEVATION SIDE TO CONTROL SEDIMENT RUNOFF.

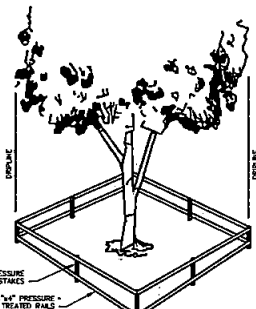

F TREE BARRICADE
NTS

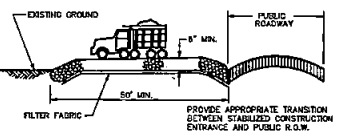

H STABILIZED CONSTRUCTION ENTRANCE DETAIL
NTS

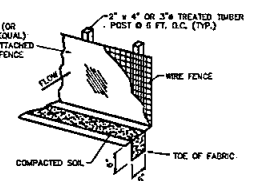

I SILT FENCE DETAIL
NTS

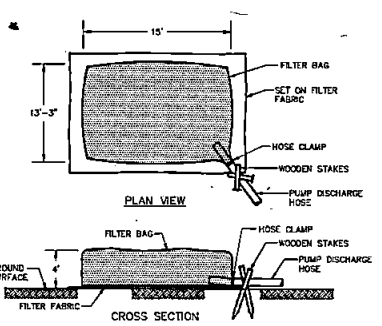

L FILTER BAG DETAILS FOR TRENCH DEWATERING OPERATIONS
NTS

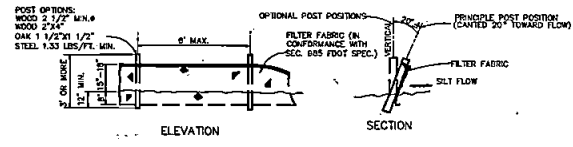

A TYPE III SILT FENCE
NTS

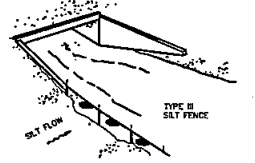

C SILT FENCE APPLICATIONS
NTS

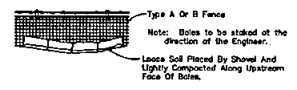

B BALES BACKED BY FENCE
NTS



TYPE II SILT FENCE

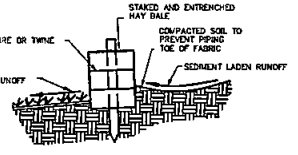

D DETAIL OF PROPERLY INSTALLED HAY BALE
NTS

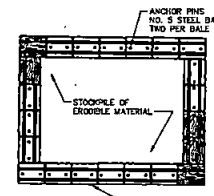

G MATERIAL STOCKPILE DETAIL
NTS

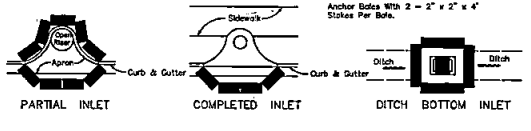

E PROTECTION AROUND INLETS OR SIMILAR STRUCTURES
NTS

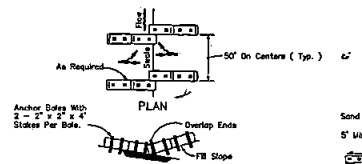

J BARRIER FOR FILL SLOPES
NTS

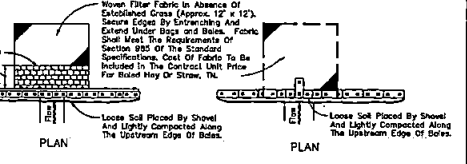

K BARRIER FOR UNPAVED DITCHES
NTS

TEMPORARY SEEDING DETAILS

SOIL TO BE THOROUGHLY PULVERIZED BY DISK-HARROWING AND BE LOOSE AND REASONABLY SMOOTH. APPLY FERTILIZER AT A RATE OF 200 LBS./ACRE OF 16-16-16 OR EQUIVALENT. APPLY COLORANT LIME AT A RATE OF 800 TO 1000 LBS./ACRE TO PROVIDE A SOIL pH OF 6.5 TO 6.8. LIME & FERTILIZER TO BE WORKED INTO THE TOPSOIL TO A DEPTH OF 4". ADD SANIT LOAM TOPSOIL TO A MINIMUM OF TWO (2) INCHES WHERE DIRECTED BY ENGINEER.

SEED MIXTURES

CONSISTING OF ANNUAL RYE (LULIM MULTIFLORA) AT A RATE OF 174 LBS./ACRE.

PERMANENT SEEDING DETAILS

SOIL TO BE THOROUGHLY PULVERIZED BY DISK-HARROWING AND BE LOOSE AND REASONABLY SMOOTH. APPLY FERTILIZER AT A RATE OF 200 LBS./ACRE OF 16-16-16 OR EQUIVALENT. APPLY COLORANT LIME AT A RATE OF 800 TO 1000 LBS./ACRE TO PROVIDE A SOIL pH OF 6.5 TO 6.8. LIME & FERTILIZER TO BE WORKED INTO THE TOPSOIL TO A DEPTH OF 4".

SEED MIXTURE CONSISTING OF	RATE	PURITY	ESTIMATION
ARGENTINE BANNA	260 LBS./AC.	95%	80%
PERSCADOLA BANNA	260 LBS./AC.	95%	80%

SOODING

SOOD SHALL BE WELL ROOT MATTED ARGENTINE BANNA GRASS COMMERCIALY CUT TO A MINIMUM DIMENSION OF 12" x 24" A MAXIMUM OF 72 HOURS PRIOR TO PLACEMENT. SOOD SHALL BE LIVE, FRESH AND SURFACED REASONABLY FREE OF WEEDS AND OTHER GRASSES. WITH A HEAVY SOIL MAT ADHERING TO THE ROOT SYSTEM. SOOD SHALL BE CROWN CUT, AND SUPPLIED BY A STATE CERTIFIED GROWER.

TREE PROTECTION

1. DAMAGED BRANCHES OR EXPOSED ROOTS WILL BE PAINTED IMMEDIATELY WITH A COMMERCIAL GRADE OF "TREE PAINT".
2. TREE LIMB REMOVAL, WHERE NECESSARY, WILL BE DONE FLUSH TO TRUNK OR MAIN BRANCH AND THAT AREA PAINTED IMMEDIATELY WITH A COMMERCIAL GRADE OF TREE PAINT.

DUST CONTROL

1. ALL AREAS OF CLEARING AND EXCAVATION AS WELL AS CONSTRUCTION HAIL ROADS SHALL BE TREATED AND MAINTAINED IN SUCH A MANNER AS TO MINIMIZE ANY DUST GENERATION.
2. DISTURBED AREAS SHALL BE MAINTAINED IN A ROUGH GRADED CONDITION AND TEMPORARILY SEEDING AND/OR MULCHED UNTIL PROPER WEATHER CONDITIONS EXIST FOR THE ESTABLISHMENT OF PERMANENT VEGETATION COVER.
3. IN EVENT OF EMERGENCY CONDITIONS, TILLAGE WILL BE SATISFACTORY FREE BEFORE SOIL BLOWING STARTS.

NO.	BY	DATE	SYMBOL	REVISIONS

M M
McDonald
McDonald Florida, LLC

Architects Engineers Surveyors
AA-C0000035 EB-00001155 LB-0000783
10245 Cantonment Pkwy., N. Suite 320
Jacksonville, Florida 32256
Telephone: (904) 203-1050

DESIGNER: L. TRACY
DRAWN BY: L. JACOB
DATE: JAN 2022
CHECKED BY: L. SAMES
DATE: JAN 2022

DESIGN ENGINEER
LESLIE S. SAMES, P.E.
FLORIDA REGISTRATION NO.
68763

St. Johns County
Utility Department
1205 STATE ROAD 18
ST. AUGUSTINE, FL 32084
PHONE: (904) 203-3228 FAX: (904) 203-2627

SAWGRASS WWTP - EXISTING
MASTER LIFT STATION AND PIPING
IMPROVEMENTS

STORMWATER AND
EROSION CONTROL DETAILS

SHEET NO. #
DWG NO. CD-1
100% SUBMITTAL

File: Job: 07_2022 - 1349
 User: A:\architect\165858\DWG\SHEDDING - Current layout.tbl - CD-1
 Xref: A:\architect - SCUD_2024_LB01 [A:\architect\165858\SCUD_22\XLA_B01.dwg]

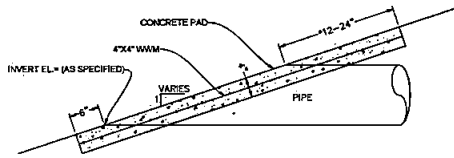

NOTE
CUT DRAIN PIPE ENDS TO MITERED SECTIONS. COMPACT SOIL ADJACENT TO ENDS AND SOO ACCORDINGLY. ALSO, COMPACT SOIL LIFT COVERING DRAIN PIPES AND SOO ACCORDINGLY.

1/4" TO 6" PIPE = 12" CONCRETE ABOVE PIPE
10" TO 12" PIPE = 18" CONCRETE ABOVE PIPE
12" PIPE = 24" CONCRETE ABOVE PIPE

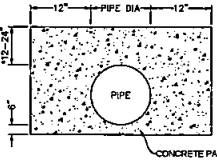

A MITERED END SECTION DETAIL
NTS

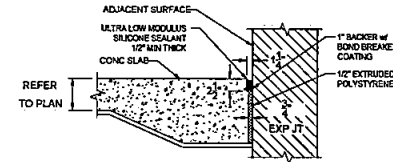

C EXPANSION JOINT DETAIL
NTS

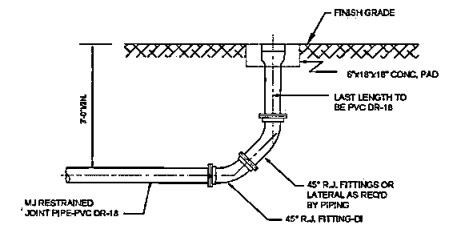

F TYPICAL GRAVITY LINE CLEANOUT
NTS

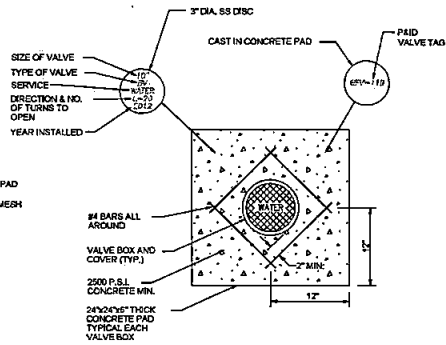
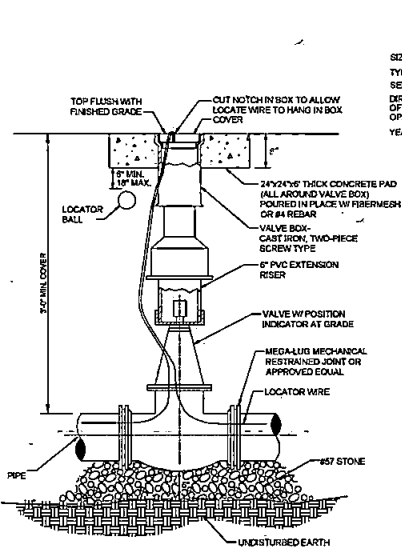

- NOTES:
1. NUT EXTENSION REQUIRED IF VALVE NUT IS DEEPER THAN 3" BELOW GRADE.
 2. SST I.D. FOR ALL SIZES.
 3. CORE 1/2" DEEP GROOVE IN CONCRETE PAD TO DENOTE ORIENTATION OF PIPE.
 4. LOCATION OF VALVE TO BE MARKED BY LETTER "V" SCRIBED A MINIMUM OF 4" HIGH AND 1/4" DEEP IN CURB AND CURB PAINTED BLUE FOR WATER, GREEN FOR SEWER, PANTONE PURPLE 522C FOR REUSE VALVE BOX CENTERS SHALL BE PAINTED BLUE IF MAIN LINE VALVE; PAINTED YELLOW IF SERVICE FIRE HYDRANT ONLY.
 5. VALVE BOX COVERS SHALL INCLUDE SERVICE DESIGNATION: WATER, SEWER, OR REUSE.
 6. NEW VALVE PADS AND VALVE TAGGING SHALL BE INSTALLED FOR ALL EXISTING VALVES.

D VALVE AND VALVE BOX
NTS

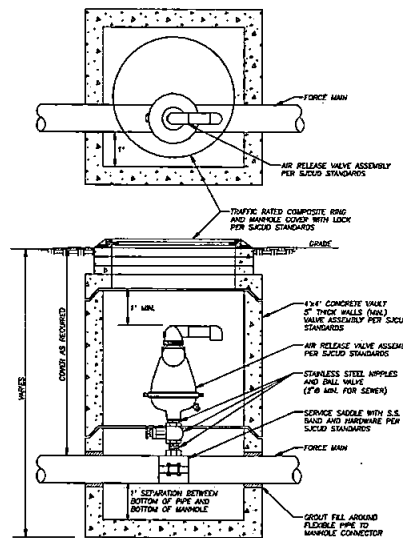

- NOTE:
1. VALVE ASSEMBLIES TO BE LOCATED OUTSIDE OF ROADWAY PAVING.
 2. PIPE PENETRATIONS SHALL BE WITH A FLEXIBLE MANHOLE SLEEVE.
 3. PIPE PENETRATIONS SHALL BE LOCATED OFF CENTER SO EDGE OF PIPE IS 1 FOOT FROM INSIDE WALL.
 4. THE INTERIOR AND EXTERIOR OF MANHOLE AND THE INTERIOR OF ADJACENT RINGS SHALL BE GIVEN TWO COATS OF SUBSTRATE BUILDUP/PROOFED MATERIAL DO NOT COAT JOINT OR PIPE JOINT SURFACES.
 5. I.D. SHALL SPECIFY "M" AND "N".

E FORCE MAIN AIR VALVE ASSEMBLY WITH MANHOLE
NTS

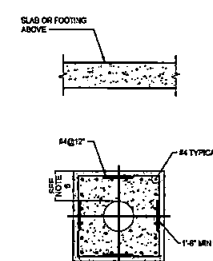

- PIPE ENCASMENT NOTES:
1. ALL PIPE SHALL BE PRESSURE TESTED BEFORE CONCRETE PLACEMENT.
 2. ALL BELOW GRADE PIPES SHALL BE SUPPORTED ON CONCRETE BLOCKS PRIOR TO CASTING OF CONCRETE BEDDING. SIZE AND SPACING OF CONCRETE BLOCK SUPPORTS SHALL BE PER PIPE MANUFACTURER.
 3. FOR ALL PIPES 12-INCH DIAMETER AND LARGER, ENCASMENT SHALL BE CAST IN TWO POURS. INITIAL CAST SHALL BE CURED FOR 12 HOURS BEFORE CASTING THE SECOND POUR.
 4. ENCASE ALL PIPES BELOW SLABS AND FOOTINGS. COVERED ENCASMENT OF BEYOND EDGE OF SLAB OR FOOTING.
 5. ENCASMENT FOR 8" DIAMETER AND SMALLER PIPES SHALL BE OF SUFFICIENT FOR PIPE DIAMETERS GREATER THAN 8". ENCASMENT SHALL BE 12" MINIMUM.

G CONCRETE PIPE ENCASMENT
NTS

C:\Users\jacob\OneDrive\Documents\Projects\2022\2022-05-01\2022-05-01.dwg

NO.	BY	DATE	SYMBOL	#/REVISIONS
1	JACOB	05/01/2022		
2	JACOB	05/01/2022		
3	JACOB	05/01/2022		
4	JACOB	05/01/2022		

	Architects	Engineers	Surveyors
	AA - C0000035	EB - 0001515	LB - 0006783
10245 Cavitation Pkwy, N. Suite 220	Jacksonville, Florida 32256	Telephone: (904) 200-1050	

DESIGNER: L. TRACEY DRAWN BY: D. JACOBS DATE: JAN 2022 CHECKED BY: J. SAMEL DATE: JAN 2022	DESIGN ENGINEER: LESLIE S. SAMEL, P.E. FLORIDA REGISTRATION NO. 68763 DATE: JAN 2022		St. Johns County Utility Department 1205 STATE ROAD 18 ST. AUGUSTINE, FL 32084 PHONE: (904) 200-2020 FAX: (904) 200-2027
--	--	--	--

SAWGRASS WWTP - EXISTING MASTER LIFT STATION AND PIPING IMPROVEMENTS	CIVIL DETAILS	SHEET NO. 8
		DATE: CD-2
		100% SUBMITTAL

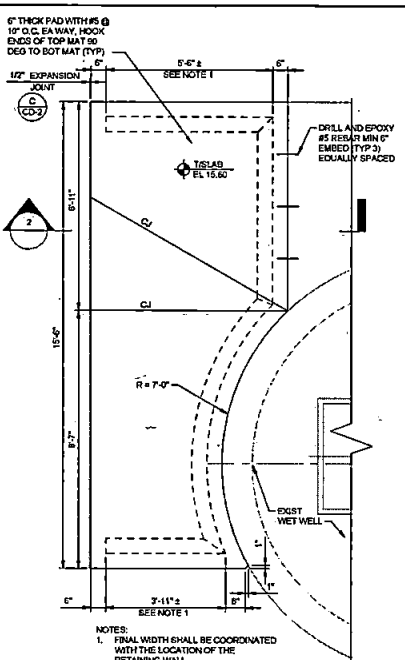
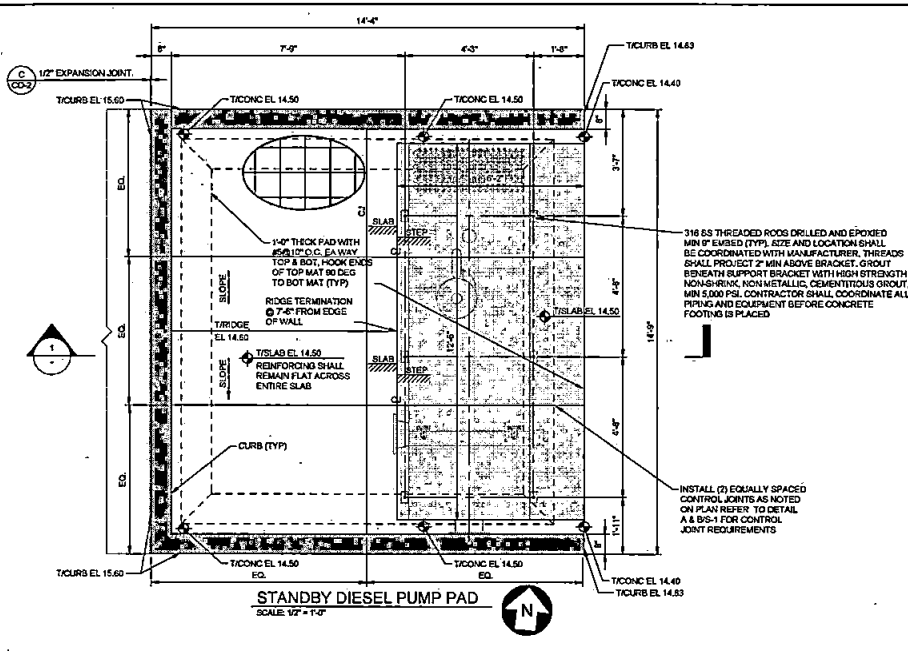

NOTES:

1. PLACE CONTROL JOINTS AT CHANGES IN SLAB WIDTH AT COLUMN LOCATIONS, COLUMN CENTERLINES, & AT REGULARLY SPACED INTERVALS.
2. MAXIMUM SPACING OF JOINTS SHALL NOT EXCEED 4'-0" FOR 4" SLABS, 12'-0" FOR 6" SLABS, AND 12'-0" FOR 8" SLABS, IN EITHER DIRECTION.
3. DO NOT EXCEED A 2 TO 1 WIDTH TO LENGTH RATIO.
4. USE CONSTRUCTION JOINTS WHEN THERE IS A BREAK IN SLAB POURING OPERATIONS EXCEEDING 30 MINUTES.

A TYPICAL SLAB ON GRADE CONTROL JOINT (CJ)
SCALE: 3/4" = 1'-0"

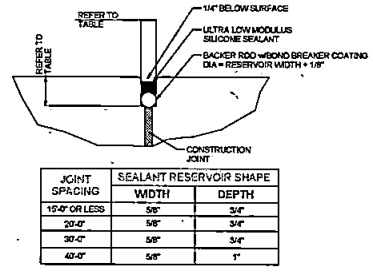

NOTES:

1. SEALANT MATERIAL SHALL BE A FIELD MOLDED SEALANT OF ONE OF THE FOLLOWING TYPES:
 1. HOT APPLIED THERMOPLASTIC ASPHALT - RUBBER COMPOUNDS MEETING ASTM 1190.
 2. HOT POURED ELASTOMERIC TYPE SEALANTS - MEETING ASTM D638.
 3. COLD APPLIED, MASTIC SINGLE OR MULTIPLE - COMPONENT SEALANTS MEETING ASTM D1830.

B TYPICAL SEALANT RESERVOIR
SCALE: 3/4" = 1'-0"

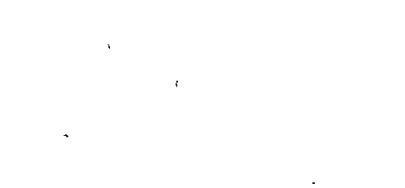
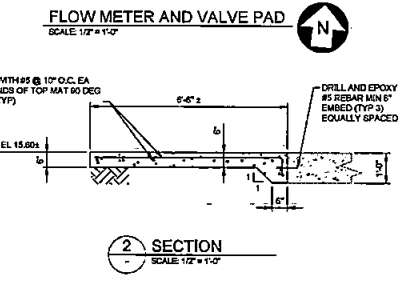
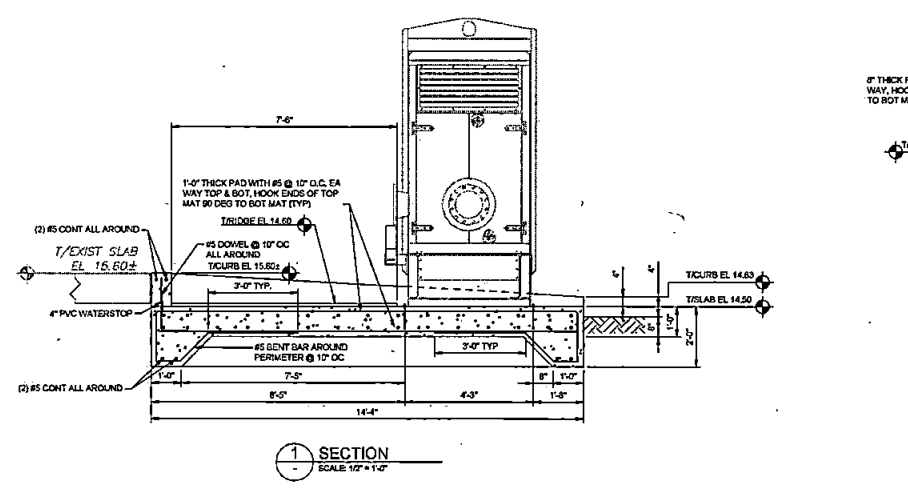

NOTES:

1. ALL COMPACTION BEHIND WALL SHALL BE COMPLETED BY HAND OPERATED PLATE COMPACTIONS. NO TRACTOR OPERATED EQUIPMENT SHALL BE UTILIZED FOR THE FILL MATERIAL BEHIND THE WALL.
2. CONTRACTOR SHALL PROVIDE AND INSTALL PERMANENT BRONZE NOTING TAGS TRACTORS OR TRUCKS BEHIND WALL.
3. BRACE WALL DURING FILL PLACEMENT AND FILL COMPACTION.

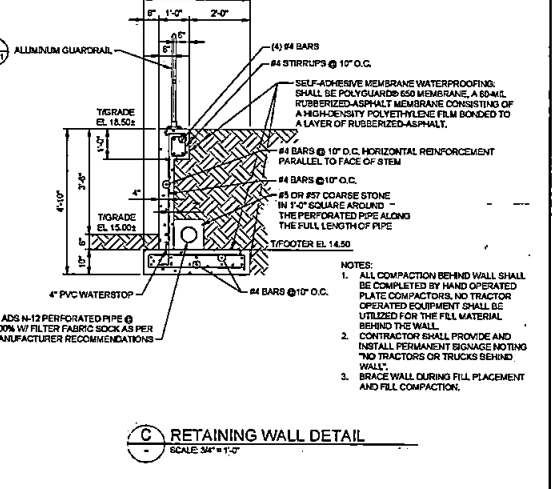

C RETAINING WALL DETAIL
SCALE: 3/4" = 1'-0"

NO.	BY	DATE	REVISION

M M McDonald Florida, LLC	Architects Engineers Surveyors	DESIGNER: C. LYNER	DESIGN ENGINEER	St. Johns County Utility Department 1205 STATE ROAD 16 ST. AUGUSTINE, FL 32084 PHONE: (904) 200-2525 FAX: (904) 200-2527	SAWGRASS WWTP - EXISTING MASTER LIFT STATION AND PIPING IMPROVEMENTS	STANDBY DIESEL PUMP PAD AND MISCELLANEOUS PADS	SHEET NO. #
	AA - C0000035 EB - 0000155 LB - 0006783 12025 Centurion Flow, N., Suite 300 Jacksonville, Florida 32256 Telephone: (904) 200-1030	DRAWN BY: D. JACOBS DATE: JUN 2022 CHECKED BY: C. LYNER DATE: JAN 2022	FLORIDA REGISTRATION NO. 66277				ENGINO B-1 10/6 SUBMITTAL

X:\Projects\2022-23\AA - C0000035 EB - 0000155 LB - 0006783.dwg
 Scale: 2022-23-AA - C0000035 EB - 0000155 LB - 0006783.dwg
 User: C. LYNER
 Date: Jan 11, 2022
 Time: 11:22:22 AM
 Sheet: 1 of 1
 Plot: 10/6 SUBMITTAL

Notes: A3-14002955 (L:\603335\10-14002955.dwg) [4]
 S:\00_2324_001 (L:\603335\10-14002955.dwg)
 PROJECT: 102929 (L:\603335\10-14002955.dwg) [2]
 Commit Level: Top = 14-1 Thu Jan 13, 2022 - 17:28

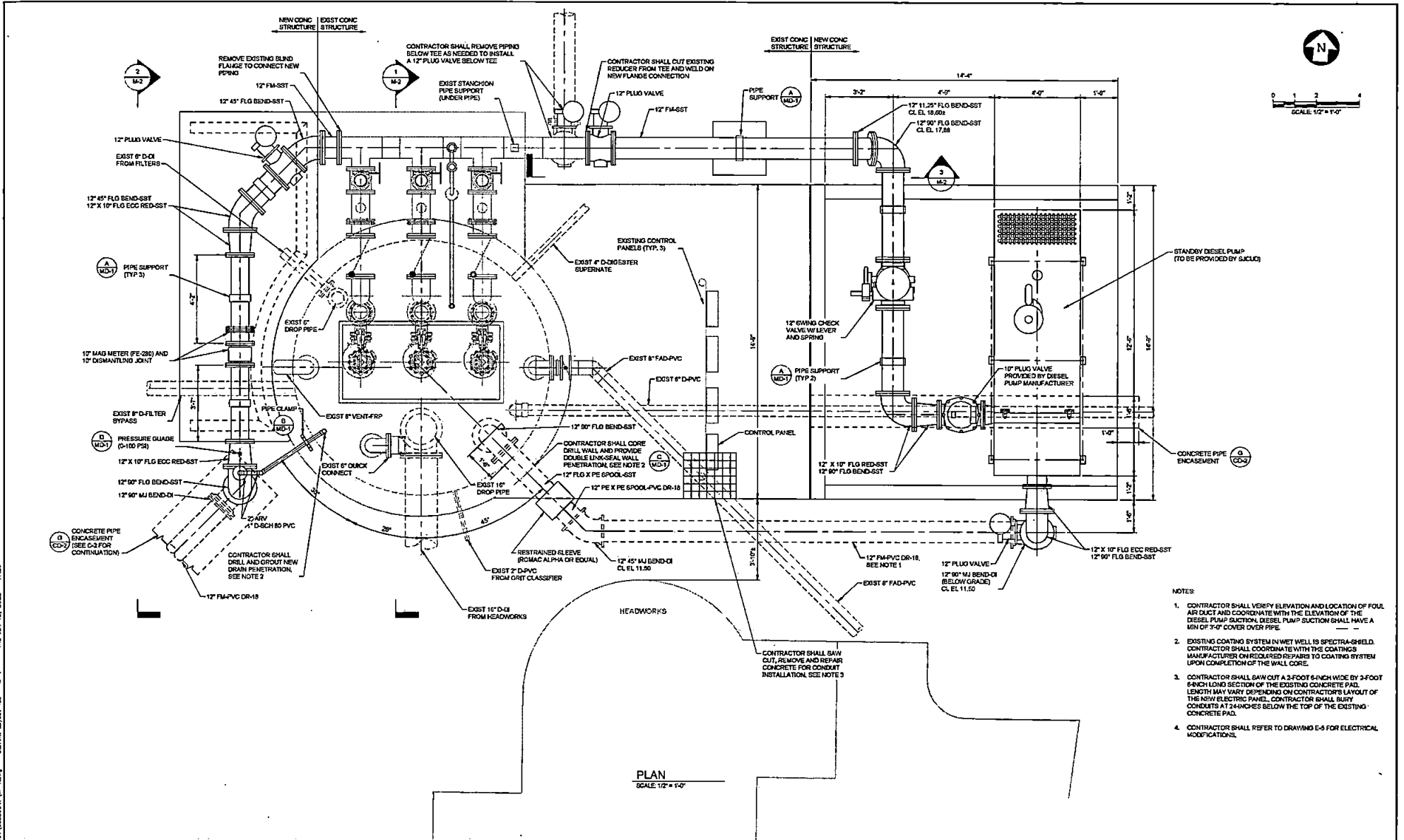

- NOTES**
- CONTRACTOR SHALL VERIFY ELEVATION AND LOCATION OF FOUL AIR DUCT AND COORDINATE WITH THE ELEVATION OF THE DIESEL PUMP SUCTION. DIESEL PUMP SUCTION SHALL HAVE A MIN OF 3'-0" COVER OVER PIPE.
 - EXISTING COATING SYSTEM IN WET WELL IS SPECTRA-SHIELD. CONTRACTOR SHALL COORDINATE WITH THE COATING'S MANUFACTURER ON REQUIRED REPAIRS TO COATING SYSTEM UPON COMPLETION OF THE WALL CORE.
 - CONTRACTOR SHALL SAW CUT A 2-FOOT 6-INCH WIDE BY 3-FOOT 6-INCH LONG SECTION OF THE EXISTING CONCRETE PAD. LENGTH MAY VARY DEPENDING ON CONTRACTOR'S LAYOUT OF THE NEW ELECTRICAL PANEL. CONTRACTOR SHALL BURY CONCRETE AT 2-INCHES BELOW THE TOP OF THE EXISTING CONCRETE PAD.
 - CONTRACTOR SHALL REFER TO DRAWING E-5 FOR ELECTRICAL MODIFICATIONS.

NO.	BY	DATE	SYMBOL	REVISIONS

M
MacDonald
 Mot MacDonald Florida, LLC

Architects Engineers Surveyors
 AA - 00000035 EB - 00001155 LB - 0006783
 10245 Cavallaro Pkwy, N., Suite 300
 Jacksonville, Florida 32256
 Telephone: (904) 203-1090

DESIGNER: ULTRACY
 DRAWN BY: D.JACOBS
 DATE: JAN 2022
 CHECKED BY: L.SAMEL
 DATE: JAN 2022

DESIGN ENGINEER
LESLIE S. SAMEL, P.E.
 FLORIDA REGISTRATION NO.
 68763

St. Johns County
Utility Department
 1205 STATE ROAD 10
 ST. AUGUSTINE, FL 32084
 PHONE: (904) 203-2030 FAX: (904) 203-2027

SAWCROSS WWTP - EXISTING MASTER LIFT STATION AND PIPING IMPROVEMENTS
MASTER LIFT STATION IMPROVEMENTS PLAN MODIFICATIONS
 SHEET NO. # 5
 DRAWING: M-1
 100% SUBMITTAL

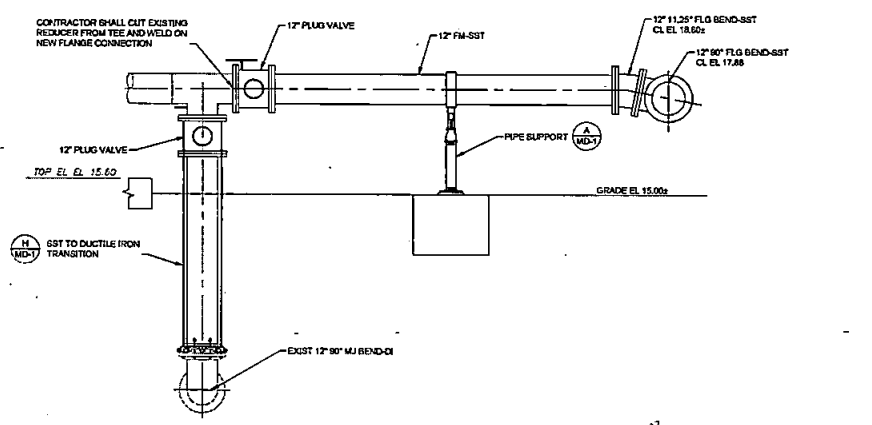
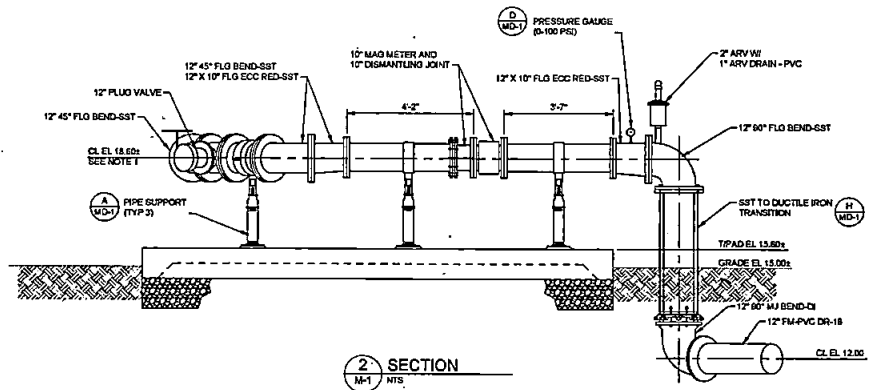
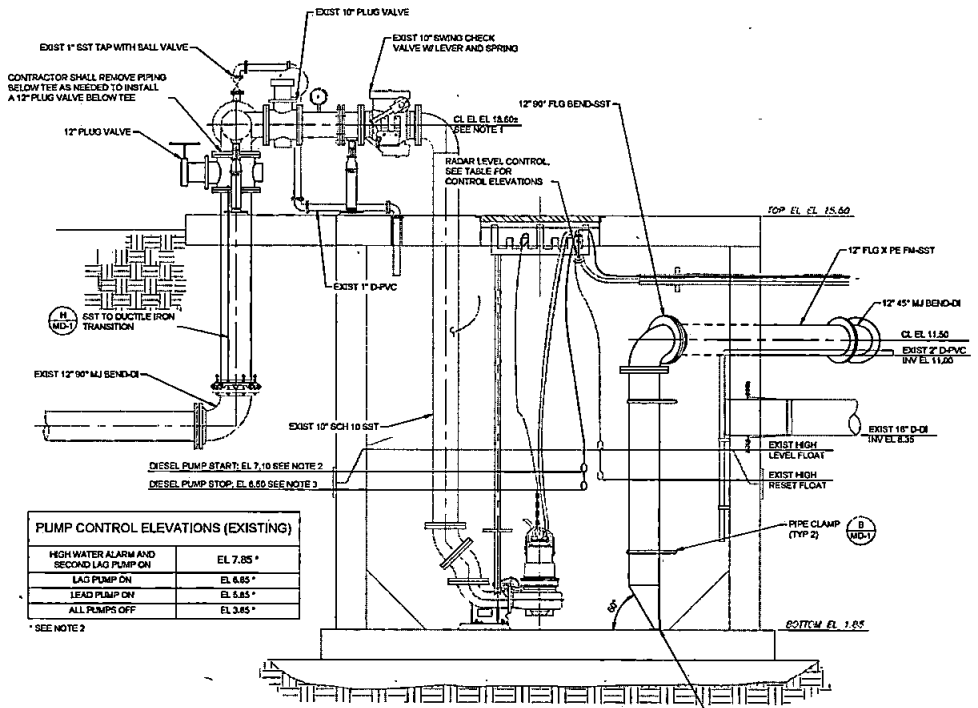
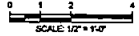

PUMP CONTROL ELEVATIONS (EXISTING)	
HIGH WATER ALARM AND SECOND LAG PUMP ON	EL 7.85'
LAD PUMP ON	EL 6.65'
HEAD PUMP ON	EL 5.85'
ALL PUMPS OFF	EL 3.85'

1 SECTION
M-1 NTS

2 SECTION
M-1 NTS

3 SECTION
M-1 NTS

- NOTES:
- ELEVATION OF EXISTING PIPING WAS NOT SURVEYED. CONTRACTOR SHALL VERIFY PIPING ELEVATIONS PRIOR TO SUBMITTING PIPE LAYOUT DRAWINGS. CONTRACTOR SHALL COORDINATE ELEVATIONS OF PROPOSED PIPING WITH THE EXISTING PIPING.
 - THESE ELEVATIONS MAY BE MODIFIED BY SURVEY OPERATIONS DURING STARTUP.
 - THIS ELEVATION SHALL NOT BE LOWERED.

Xref: Attaché - 48-400255 (L:\03\35\048-400255.dwg)
 SAUD_2314.dwg (L:\03\35\048-400255.dwg, 2314.dwg)
 SAUD_2314.dwg (L:\03\35\048-400255.dwg, 2314.dwg)
 SAUD_2314.dwg (L:\03\35\048-400255.dwg, 2314.dwg)

This Jan 13, 2022 - 17:22
 Current Layer: Top = 10-2

	Architects Engineers Surveyors AA - 0000035 EB - 0000155 LB - 0008783 10245 Centurian Pkwy., N. Suite 300 Jacksonville, Florida 32256 Telephone: (904) 203-1950	DESIGNER: L. TRACY DRAWN BY: D. JACKSON DATE: JAN 2022 CHECKED BY: L. SAMEL DATE: JAN 2022	DESIGN ENGINEER LESLIE S. SAMEL, P.E. FLORIDA REGISTRATION NO. 68763	St. Johns County Utility Department 1205 STATE ROAD 10 ST. AUGUSTINE, FL 32084 PHONE: (904) 209-2626 FAX: (904) 209-2627	SAWGRASS WWTP - EXISTING MASTER LIFT STATION AND PIPING IMPROVEMENTS	MASTER LIFT STATION IMPROVEMENTS SECTIONS AND DETAILS	SHEET NO. # 1 DWG NO. 1A-2 100% SUBMITTAL
	REVISIONS						

Made Atchd - AA-0000000 [Veridation] - AA-0000000 (Rev. 1/10)
 S:\00_2214_001 [Veridation] - AA-0000000 (Rev. 1/10)
 S:\00_2214_001 [Veridation] - AA-0000000 (Rev. 1/10)
 S:\00_2214_001 [Veridation] - AA-0000000 (Rev. 1/10)

Thu Jun 13, 2022 11:10
 Current Layout Tab = M-3

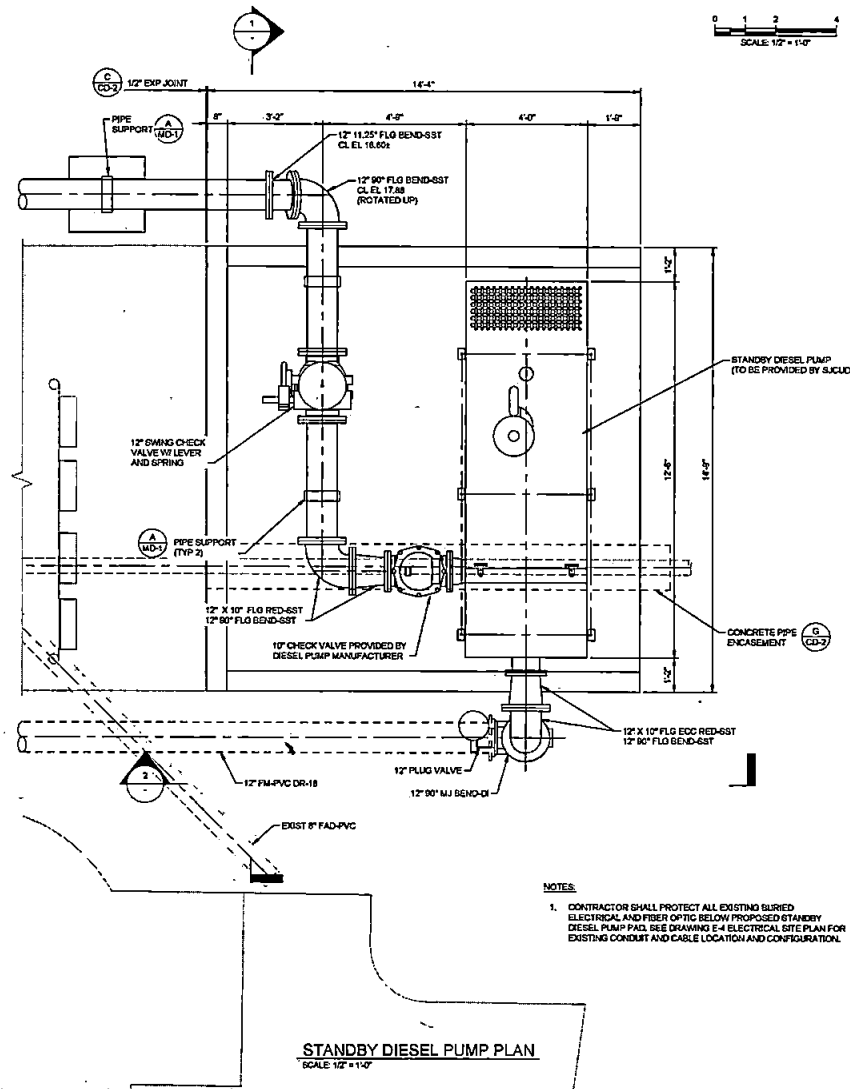

- NOTES:**
- CONTRACTOR SHALL PROTECT ALL EXISTING BURIED ELECTRICAL AND FIBER OPTIC BELOW PROPOSED STANDBY DIESEL PUMP PADS. SEE DRAWING E-4 ELECTRICAL SITE PLAN FOR EXISTING CONDUIT AND CABLE LOCATION AND CONFIGURATION.

STANDBY DIESEL PUMP PLAN
SCALE: 1/2" = 1'-0"

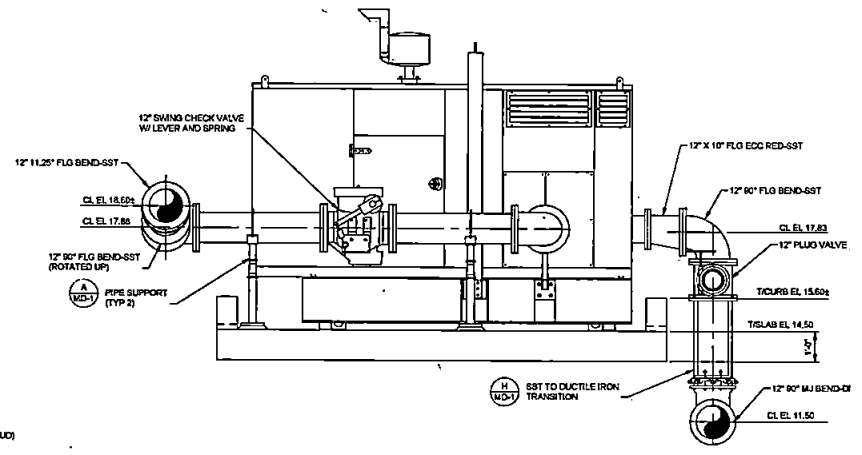

1 SECTION
SCALE: 1/2" = 1'-0"

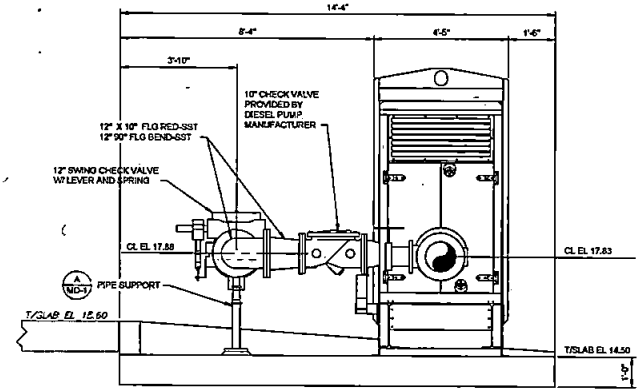

2 SECTION
SCALE: 1/2" = 1'-0"

NO.	BY	DATE	REVISION

M M
 MOTT
 MOTT
 Mott MacDonald Florida, LLC

Architects Engineers Surveyors
 AA - C0000035 EB - 0000155 LB - 0000783
 10245 Centerton Pkwy, N. Suite 320
 Jacksonville, Florida 32256
 Telephone: (904) 203-1000

DESIGNER: L. TRACEY
 DRAWN BY: D. JACOBS
 DATE: JAN 2022
 CHECKED BY: L. SAMEL
 DATE: JAN 2022

DESIGN ENGINEER
 LESLIE S. SAMEL, P.E.
 FLORIDA REGISTRATION NO.
 08763



St. Johns County
Utility Department
 1205 STATE ROAD 18
 ST. AUGUSTINE, FL 32084
 PHONE: (904) 200-2020 FAX: (904) 200-2827

SAWGRASS WWTP - EXISTING
 MASTER LIFT STATION AND PIPING
 IMPROVEMENTS

STANDBY DIESEL PUMP
 PLAN AND SECTIONS

SHEET NO. #
 10
 DRAWING
 M-3
 100% SUBMITTAL

PIPE SIZE	A	B	C	D	E MIN.	E MAX.	F	G	H
3/4"	2 1/2"	3 1/2"	5"	1 1/2"	8"	13"	1 1/2"	3/8"	3/8"
1"	3 1/2"	4 1/2"	6"	1 1/2"	8 1/4"	13 1/4"	1 1/2"	3/8"	3/8"
1 1/4"	4 1/2"	5 1/2"	7"	1 1/2"	8 1/2"	14"	1 1/2"	3/8"	3/8"
1 1/2"	4 1/2"	5 1/2"	7"	1 1/2"	10"	14 3/4"	1 1/2"	3/8"	3/8"
1 3/4"	5 1/2"	6 1/2"	8"	1 1/2"	10 1/2"	15 1/4"	1 1/2"	3/8"	3/8"
2"	6 1/2"	7 1/2"	9"	1 1/2"	11 3/4"	16 1/2"	1 1/2"	3/8"	3/8"
2 1/2"	7 1/2"	8 1/2"	10"	1 1/2"	13 1/2"	18 1/4"	1 1/2"	3/8"	3/8"
3"	8 1/2"	9 1/2"	11"	1 1/2"	15 1/4"	19 3/4"	1 1/2"	3/8"	3/8"

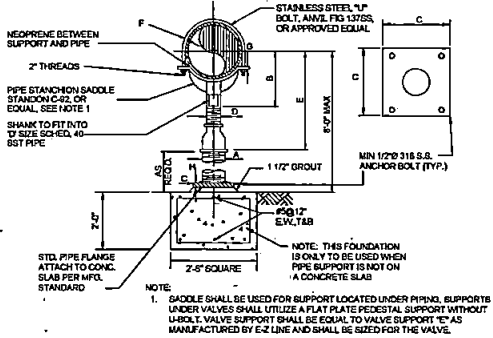
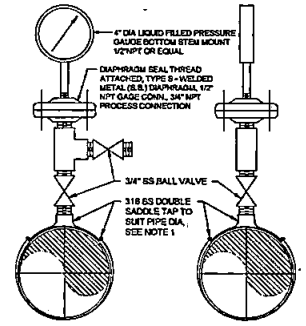
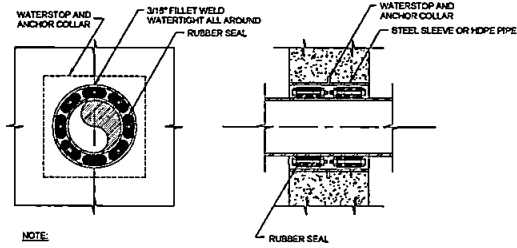
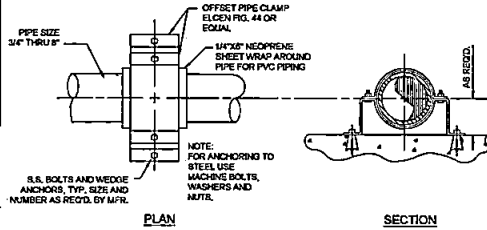

A 304 SS PIPE SUPPORT
NTS

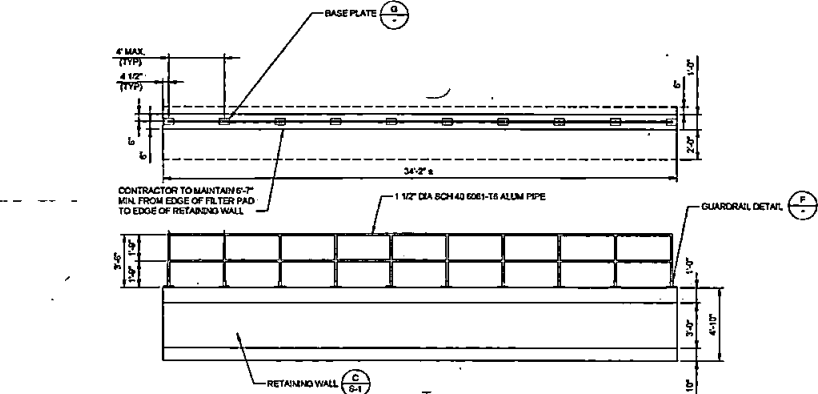

E ALUMINUM GUARDRAIL
SCALE: 1/4\"/>

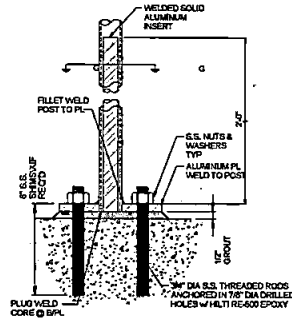

F GUARDRAIL DETAIL
SCALE: 3\"/>

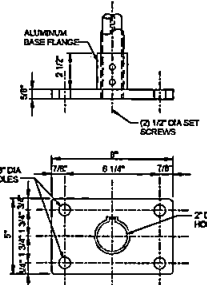

G BASE PLATE
SCALE: 3\"/>

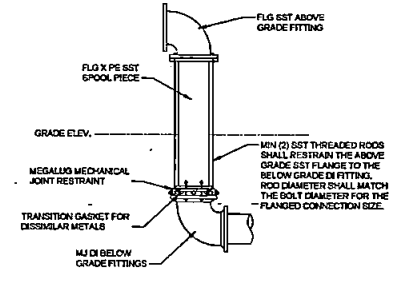

H SST TO DUCTILE IRON TRANSITION DETAIL
SCALE: 1/2\"/>

NO.	BY	DATE	SYMBOL	REVISIONS
1				

M
M
Moffitt MacDonell
More MacDonell Florida, LLC

Architects Engineers Surveyors
AA-C0000035 EB-0000155 LB-0000783
10245 Cantonment Pkwy, N. Suite 320
Jacksonville, Florida 32256
Telephone: (904) 203-1000

DESIGNER: L. TRACY
DRAWN BY: G. JACOBS
DATE: JUN 2022
CHECKED BY: L. SAMEL
DATE: JAN 2022

DESIGN ENGINEER
LESLIE S. SAMEL, P.E.
FLORIDA REGISTRATION NO.
68763



St. Johns County
Utility Department
1200 STATE ROAD 18
ST. AUGUSTINE, FL 32084
PHONE: (904) 200-2020 FAX: (904) 200-2827

SAWGRASS WWTP - EXISTING
MASTER LIFT STATION AND PIPING
IMPROVEMENTS

MECHANICAL DETAILS

SHEET NO. #
11
DATE
REV. 1
100% SUBMITTAL

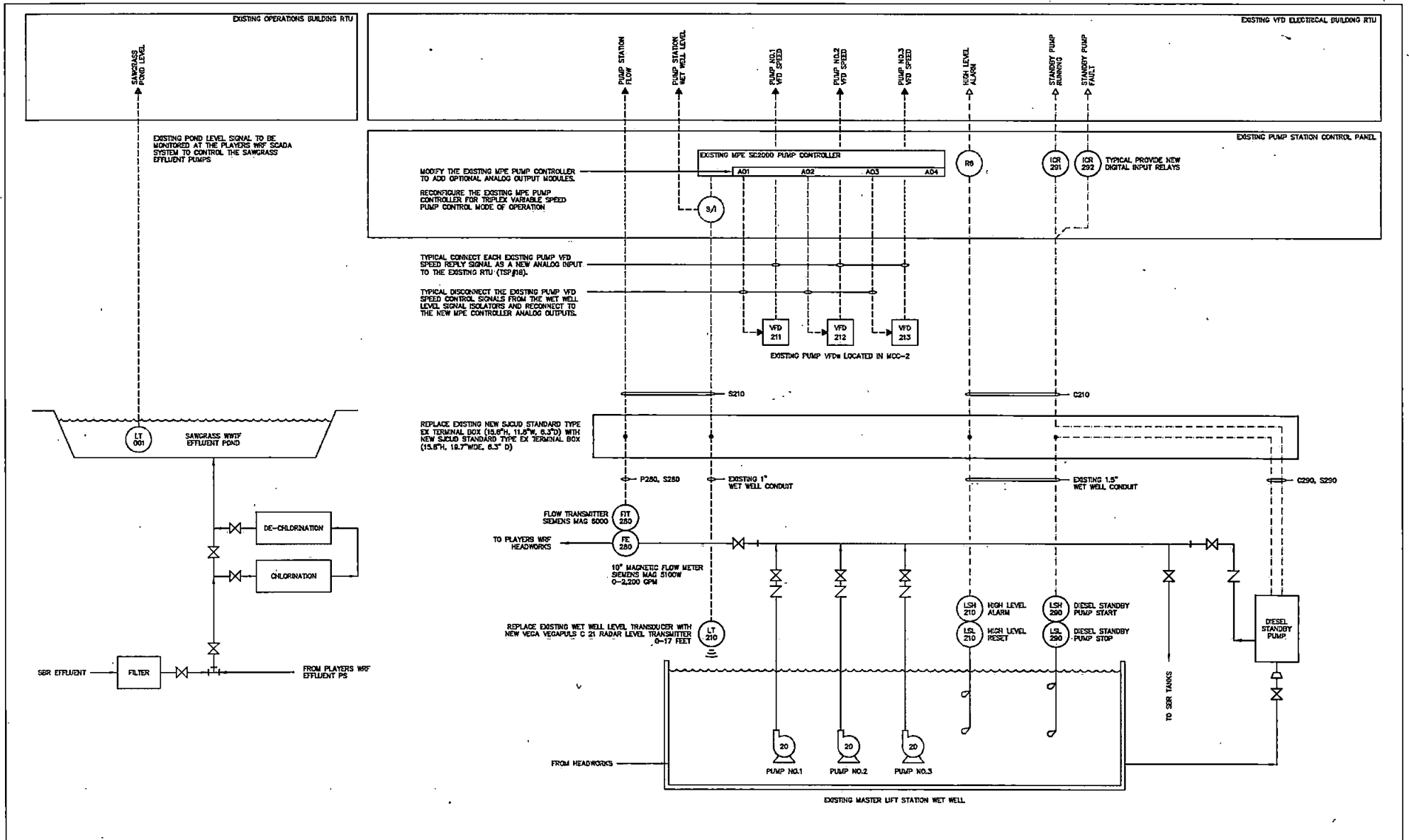

NO.	BY	DATE	SYMBOL	REVISIONS
1				
2				
3				
4				
5				

M M MOTT MACDONALD Mott MacDonald Florida, LLC	Architects Engineers Surveyors AA-C0000035 EB-0000155 LB-0006743 10245 Centerton Place, N., Suite 320 Jacksonville, Florida 32256 Telephone: (904) 253-1000	DESIGNER: D. LASSETTER DRAWING NO: E-15E DATE: JAN 2022 CHECKED BY: A. GIBBS DATE: JAN 2022	DESIGN ENGINEER W. DAVID LASSETTER, P.E. FLORIDA REGISTRATION NO. 37971 3637 Buckskin Trail E Jacksonville, FL 32277 904-743-1555	St. Johns County Utility Department 1206 STATE ROAD 16 ST. AUGUSTINE, FL 32084 PHONE: (904) 206-3028 FAX: (904) 206-2927	SAWGRASS WWTP - EXISTING MASTER LIFT STATION AND PIPING IMPROVEMENTS	INSTRUMENTATION & CONTROL SCHEMATIC DIAGRAM	SHEET NO. INSTRUC E-2 100% SUBMITTAL
---	---	---	--	--	---	--	---

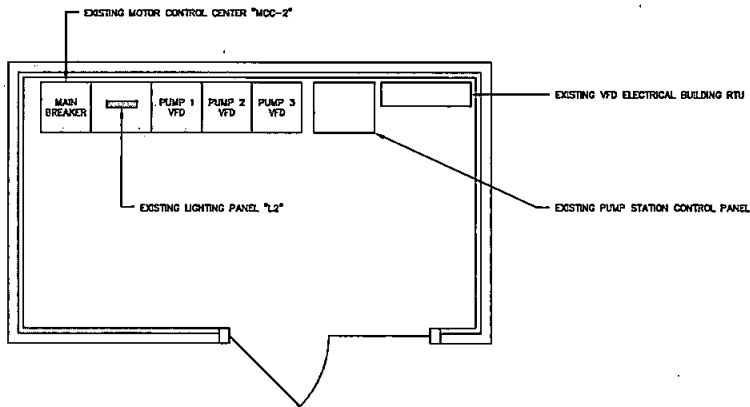

EXISTING VFD ELECTRICAL BUILDING ELECTRICAL PLAN
NOT TO SCALE

EXISTING VFD ELECTRICAL BUILDING RTU I/O SCHEDULE					
SLOT 1 - MIXED I/O MODULE		SLOT 2 - MIXED I/O MODULE		SLOT 3 - MIXED I/O MODULE	
I/O	SIGNAL DESCRIPTION	I/O	SIGNAL DESCRIPTION	I/O	SIGNAL DESCRIPTION
DI01	WET WELL TRANSDUCER HIGH LEVEL	DI01	INFLUENT SCREEN HIGH LEVEL	DI01	FILTER FLUSH VALVE IN AUTO
DI02	WET WELL FLOAT SWITCH HIGH LEVEL	DI02	INFLUENT SCREEN RUNNING	DI02	FILTER FLUSH VALVE OVERTORQUE
DI03	CONTROL POWER FAILURE	DI03	INFLUENT SCREEN FAULT	DI03	FILTER FLUSH VALVE CLOSED
DI04	POWER MONITOR PHASE LOSS	DI04	GRIT CHAMBER DRIVE RUNNING	DI04	FILTER FLUSH VALVE OPEN
DI05	PUMP 1 RUNNING ON VFD	DI05	GRIT CHAMBER DRIVE FAULT	DI05	DIESEL STANDBY PUMP RUNNING
DI06	PUMP 1 RUNNING ON BYPASS	DI06	GRIT PUMP RUNNING	DI06	DIESEL STANDBY PUMP FAULT
DI07	PUMP 1 FAIL	DI07	GRIT PUMP FAULT	DI07	SPARE
DI08	PUMP 1 VFD FAULT	DI08	GRIT CLASSIFIER RUNNING	DI08	SPARE
DI09	PUMP 2 RUNNING ON VFD	DI09	GRIT CLASSIFIER FAULT	DI09	SPARE
DI10	PUMP 2 RUNNING ON BYPASS	DI10	ODOR CONTROL FAN RUNNING	DI10	SPARE
DI11	PUMP 2 FAIL	DI11	ODOR CONTROL PUMP LOW FLOW	DI11	SPARE
DI12	PUMP 2 VFD FAULT	DI12	ODOR CONTROL SYSTEM FAULT	DI12	SPARE
DI13	PUMP 3 RUNNING ON VFD	DI13	ODOR CONTROL EYEWASH ALARM	DI13	SPARE
DI14	PUMP 3 RUNNING ON BYPASS	DI14	CENTRIFUGE RUNNING	DI14	SPARE
DI15	PUMP 3 FAIL	DI15	CENTRIFUGE FAULT	DI15	SPARE
DI16	PUMP 3 VFD FAULT	DI16	SPARE	DI16	SPARE
DO1	PUMP 1 FORCE	DO1	PUMP 3 FORCE	DO1	SPARE
DO2	PUMP 1 DISABLE	DO2	PUMP 3 DISABLE	DO2	SPARE
DO3	PUMP 2 FORCE	DO3	FILTER FLUSH VALVE OPEN/CLOSE	DO3	SPARE
DO4	PUMP 2 DISABLE	DO4	SPARE	DO4	SPARE
A1	WET WELL LEVEL	A1	CENTRIFUGE SLUDGE FLOW	A1	SPARE
A2	FORCE MAIN PRESSURE	A2	ODOR CONTROL H2S	A2	SPARE
A3	PUMP 1 VFD SPEED	A3	PUMP 3 VFD SPEED	A3	SPARE
A4	PUMP 2 VFD SPEED	A4	PUMP STATION FLOW	A4	SPARE

TYPICAL REASSIGN EXISTING
SPARE I/O POINT FOR NEW
SIGNAL

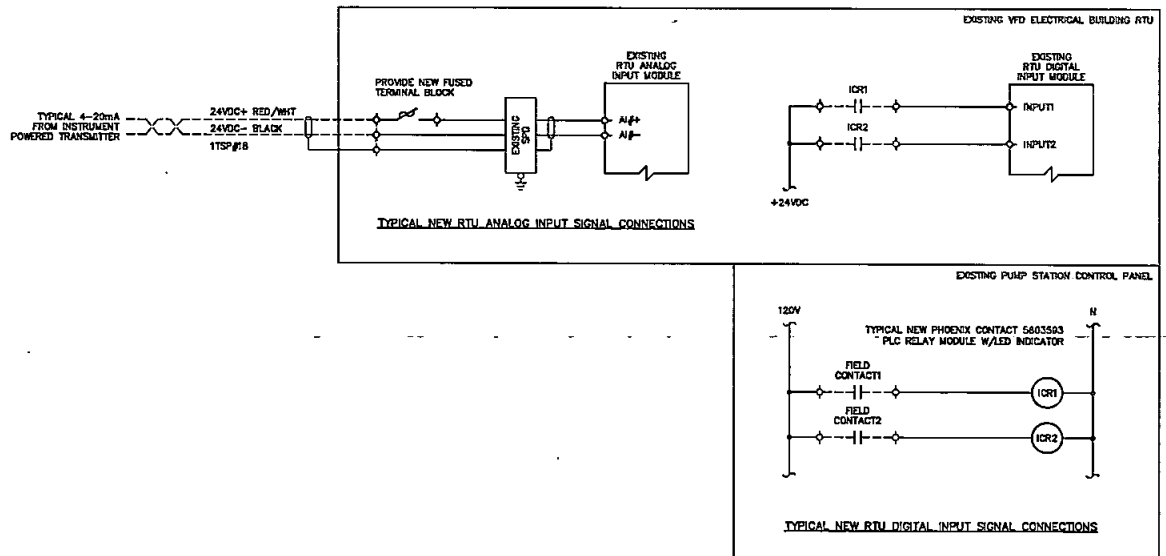

NOTES:

1. THE CONTRACTOR SHALL INSPECT THE SITE PRIOR TO BID TO EVALUATE EXISTING CONDITIONS. INSTALLATION OF THE NEW FACILITIES WILL REQUIRE FIELD COORDINATION WITH PLANT OPERATIONS TO PERMIT MAINTENANCE OF OPERATION DURING CONSTRUCTION. DURATION OF POWER OUTAGES SHALL BE MINIMUM REQUIRED FOR SAFE INSTALLATION AND SHALL BE SCHEDULED WITH AND APPROVED BY THE OWNER.
2. THE CONTRACTOR SHALL TAKE PRECAUTIONS TO AVOID EXISTING UNDERGROUND UTILITIES INCLUDING PROCESS PIPING, WATER LINES, CHEMICAL FEED PIPING, ELECTRICAL CONDUITS, TELEPHONE, ETC. HAND EXCAVATION SHALL BE REQUIRED IN CONCEALED AREAS WHERE THE EXACT LOCATION OF ALL UTILITIES IS UNKNOWN AND SURFACE LOCATION IS NOT PRACTICAL. LOCATIONS SHOWN FOR THE EXISTING UNDERGROUND UTILITIES ARE APPROXIMATE ONLY. NOT ALL OF THE EXISTING UNDERGROUND UTILITIES ARE SHOWN. FIELD ADJUST LOCATIONS OF THE NEW FACILITIES TO ACCOMMODATE THE EXISTING SITE CONDITIONS AND UNDERGROUND UTILITIES.
3. EXISTING LIGHT POLE "LP2" TO BE MODIFIED: REMOVE THE EXISTING LIGHT FIXTURE AND BRACKET AND PROMOTE NEW 3"-Ø ALUMINUM SULL HORN BRACKET AND TWO NEW LIGHT FIXTURES. LIGHT FIXTURES SHALL BE SJCD STANDARD SYLVANIA AREAFLD2A/150UNV0750/75/BZ/SUPFITTER/BZ.
4. EXISTING LIGHT POLE "LP3" TO BE REMOVED, INTERCEPT AND REROUTE THE EXISTING LIGHTING BRANCH CIRCUIT TO THE NEW RECEPTACLE AT THE MASTER LIFT STATION ELECTRICAL EQUIPMENT RACK (SEE E-5).

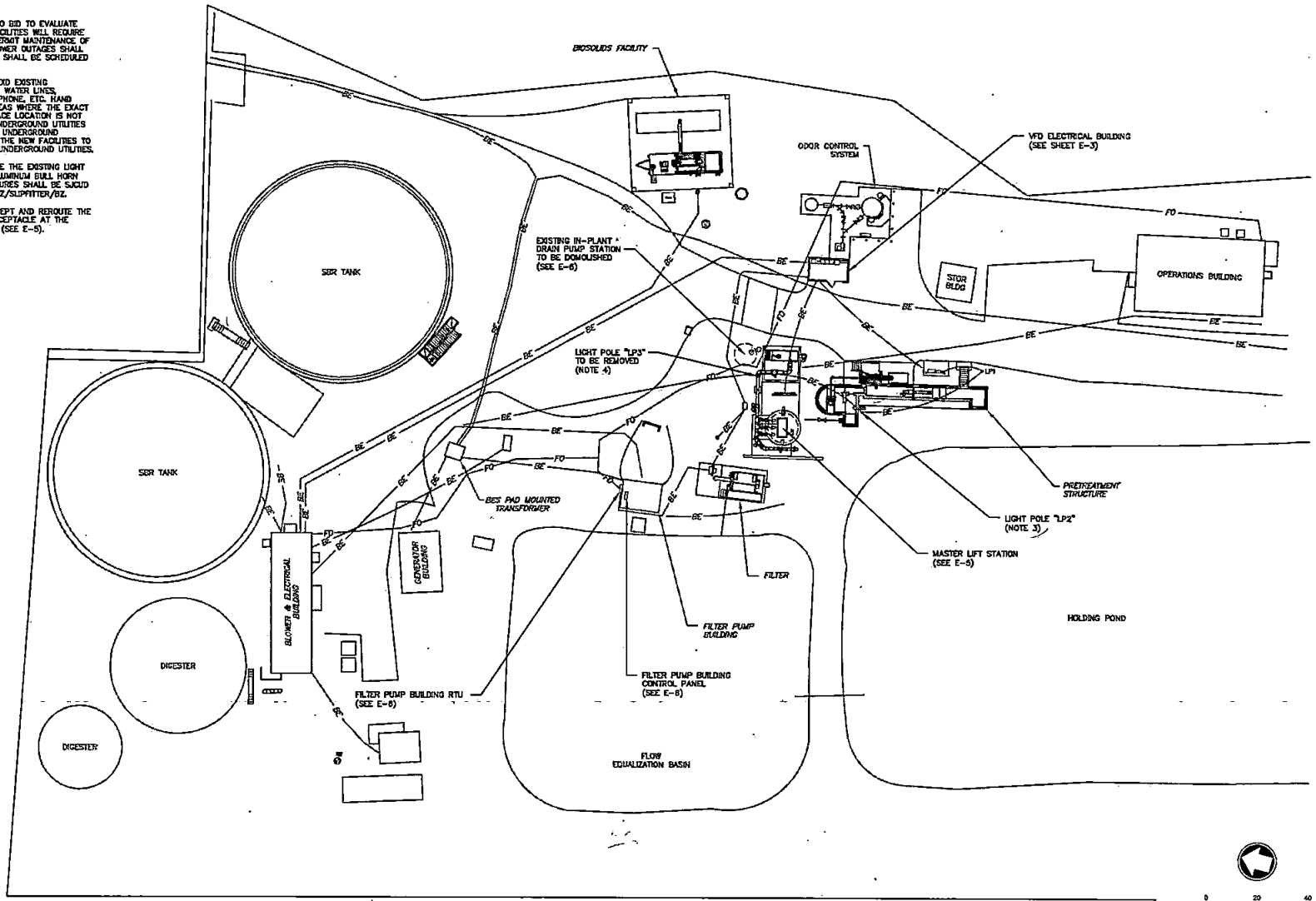

NO.	BY	DATE	SYMBOL	REVISIONS

M M MBB MacDONALD MOB MacDonald Florida, LLC	Architects Engineers Surveyors AA - C0000035 EB - 0000185 LB - 0006783 10245 Cavitation Pkwy., N., Suite 300 Jacksonville, Florida 32256 Telephone: (904) 203-1030	DESIGNER: D. LASSETTER DRAWN BY: B. LEE DATE: JAN 2002 CHECKED BY: A. GIBBS DATE: JAN 2002	DESIGN ENGINEER: W. DAVID LASSETTER, P.E. FLORIDA REGISTRATION NO. 37971 3637 Buckholz Trail E Jacksonville, FL 32277 904-743-1585	St. Johns County Utility Department 1205 STATE ROAD 16 ST. AUGUSTINE, FL 32084 PHONE: (904) 209-3028 FAX: (904) 209-2627	SAWGRASS WWTP - EXISTING MASTER LIFT STATION AND PIPING IMPROVEMENTS	ELECTRICAL SITE PLAN	SHEET NO. DWG NO. E-4 100% SUBMITTAL
--	--	--	--	--	--	----------------------	---

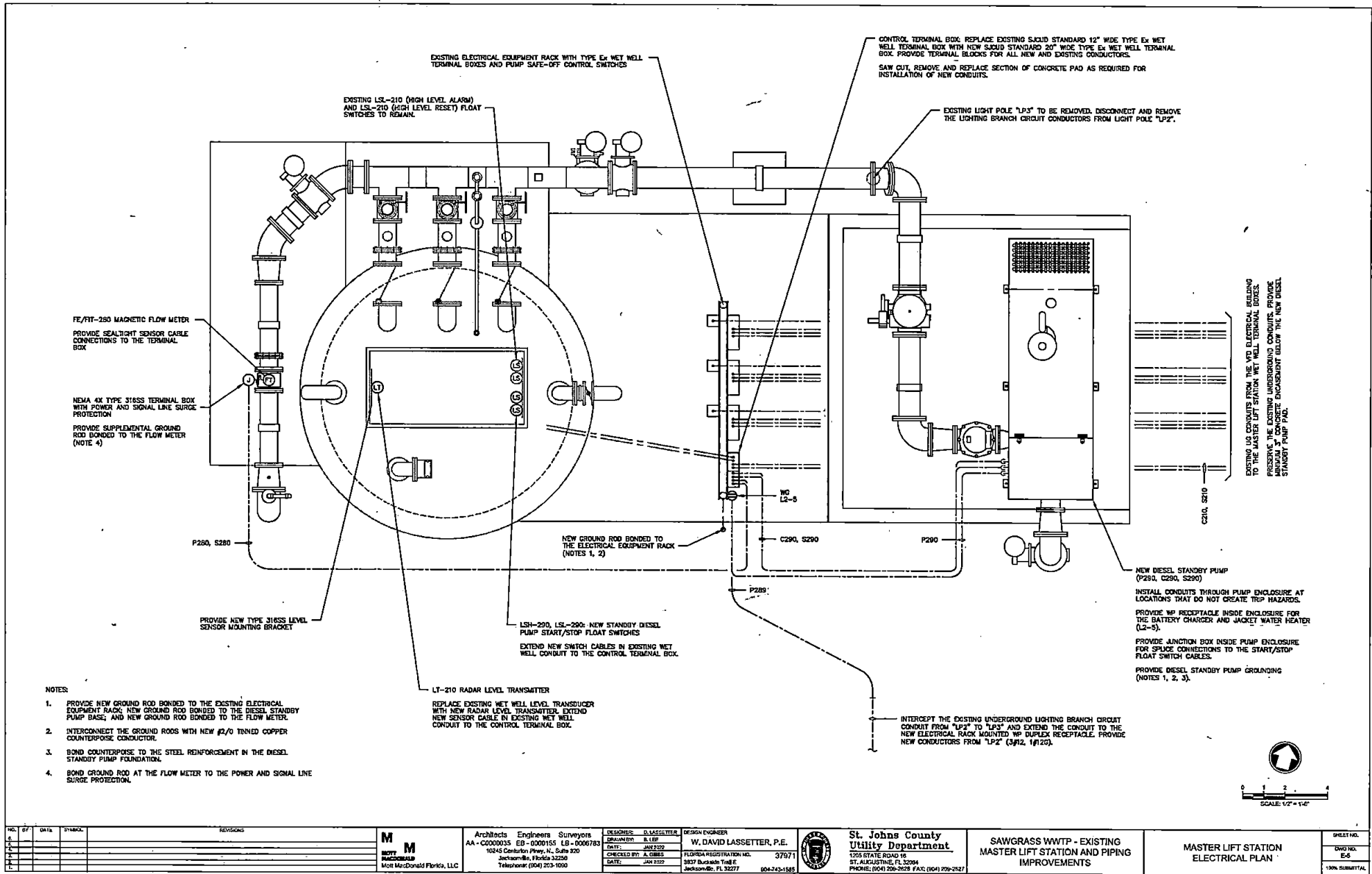

NO.	DATE	SYMBOL	REVISIONS

M M
MOFF
PACKERD
 Moir MacDonald Florida, LLC

Architects Engineers Surveyors
 AA - C0000935 EB - 00001151 LB - 00067783
 10245 Confection Drive, N. Suite 870
 Jacksonville, Florida 32256
 Telephone: (904) 203-1050

DESIGNER: D. LASSETTER
 DRAWN BY: B. LEE
 DATE: JAN 2022
 CHECKED BY: A. OMBES
 DATE: JAN 2022

DESIGN ENGINEER
W. DAVID LASSETTER, P.E.
 FLORIDA REGISTRATION NO. 37971
 3537 Bluebell Trail E
 Jacksonville, FL 32277 904-243-1585



St. Johns County
Utility Department
 1205 ESTATE ROAD 16
 ST. AUGUSTINE, FL 32084
 PHONE: (904) 296-3628 FAX: (904) 296-2527

SAWGRASS WWTP - EXISTING
MASTER LIFT STATION AND PIPING
IMPROVEMENTS

MASTER LIFT STATION
ELECTRICAL PLAN

SHEET NO.
 DWG NO.
 E-5
 100% SUBMITTAL

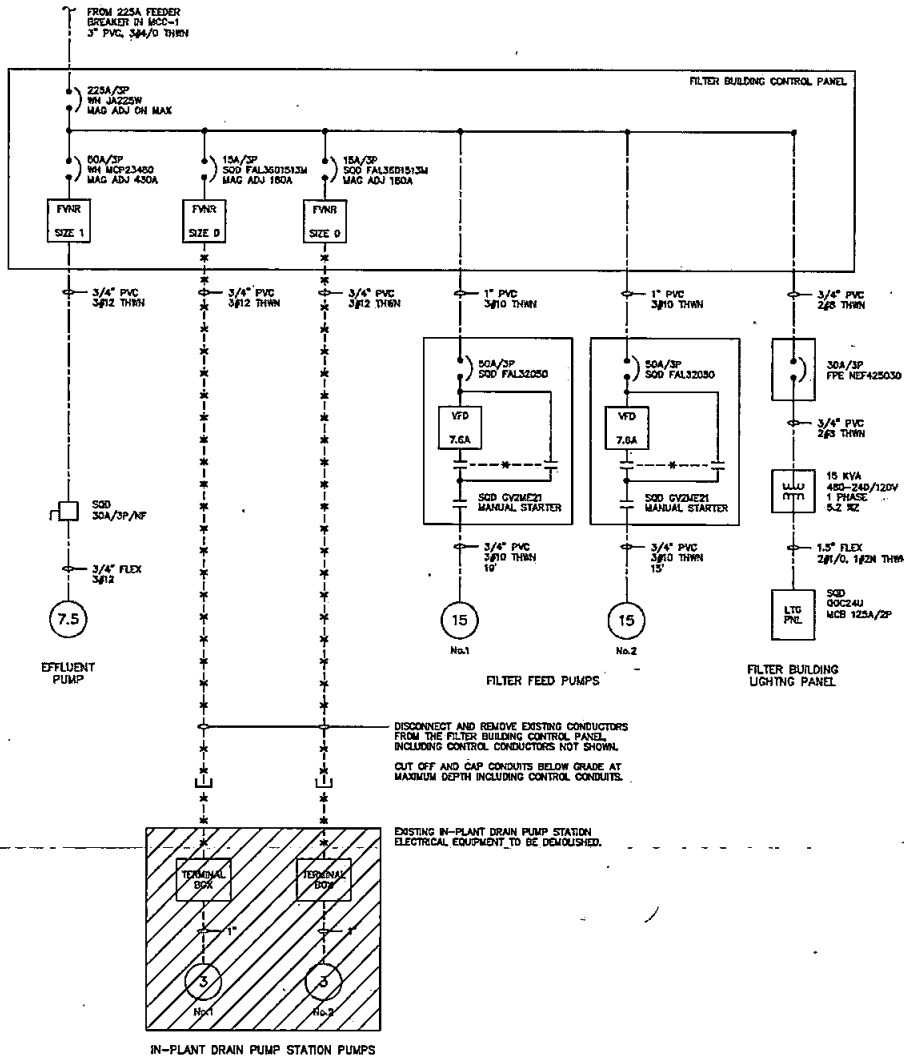

NOTES:

1. REPLACE EXISTING FIBER OPTIC CABLE PULL BOX MOUNTED ON TOP OF THE IN-PLANT DRAIN PUMP STATION WET WELL WITH A NEW TRAFFIC RATED UG PULL BOX.
2. TEMPORARILY DISCONNECT THE FIBER OPTIC CABLE AT THE FILTER PUMP BUILDING RTU AND CAREFULLY PULL BACK THE CABLE TO ALLOW THE EXISTING ABOVE GROUND PULL BOX, CONDUIT AND FITTINGS TO BE REMOVED.
3. EXTEND THE EXISTING CONDUITS BELOW GRADE INTO THE NEW UG PULL BOX.
4. RE-PULL THE FIBER OPTIC CABLE BACK TO THE FILTER PUMP BUILDING RTU, RE-TERMINATE AND RE-TEST THE EXISTING FIBERS.
5. REMOVE THE CONDUCTORS FROM ALL OTHER CONDUITS THAT ARE NO LONGER IN SERVICE IN THE ASRA TO BE DEMOLISHED. CUT OFF AND REMOVE CONDUIT SEGMENTS WITHIN THE EXCAVATED AREA. GAP AND ABANDON REMAINING EMPTY CONDUIT SEGMENTS.

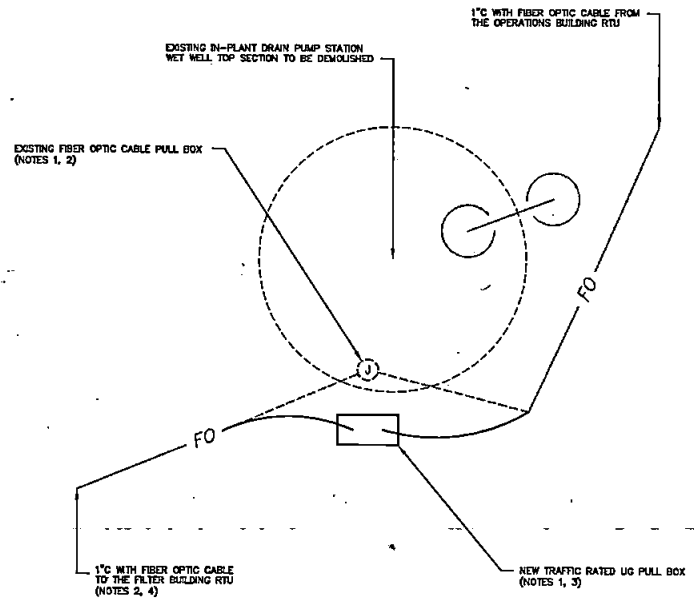

IN-PLANT DRAIN PS DEMOLITION ELECTRICAL PLAN
SCALE: 1/2" = 1'-0"

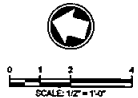

NO.	BY	DATE	SYMBOL	REVISIONS
1				
2				
3				
4				



Architects Engineers Surveyors
AA - C0000035 EB - 0000155 LB - 0006783
16249 Conurbation Pkwy, N., Suite 320
Jacksonville, Florida 32258
Telephone: (904) 253-1000

DESIGNER: D. LASSETTER
DRAWN BY: B. LEE
DATE: JAN 2022
CHECKED BY: A. COLES
DATE: JAN 2022
DESIGN ENGINEER
W. DAVID LASSETTER, P.E.
FLORIDA REGISTRATION NO.: 37571
3837 Buckwheat Trail E
Jacksonville, FL 32217
904-743-1553



St. Johns County
Utility Department
1205 STATE ROAD 16
ST. AUGUSTINE, FL 32084
(PHONE: (904) 209-2625 FAX: (904) 209-2627

SAWGRASS WWTP - EXISTING
MASTER LIFT STATION AND PIPING
IMPROVEMENTS

IN-PLANT DRAIN PS DEMOLITION
ELECTRICAL PLAN

SHEET NO.
DWG NO.
E-6
100% SUBMITTAL

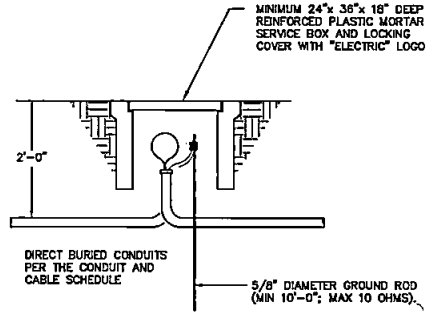

TYPICAL UNDERGROUND PULL BOX DETAIL
NOT TO SCALE

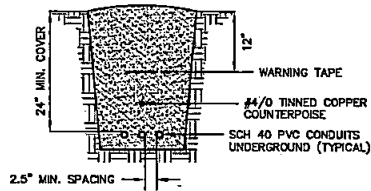

TYPICAL DIRECT BURIED CONDUIT DETAIL
NOT TO SCALE

NOTE: SEE ELECTRICAL SITE PLAN AND CONDUIT AND CABLE SCHEDULE FOR NUMBER AND SIZE OF CONDUITS

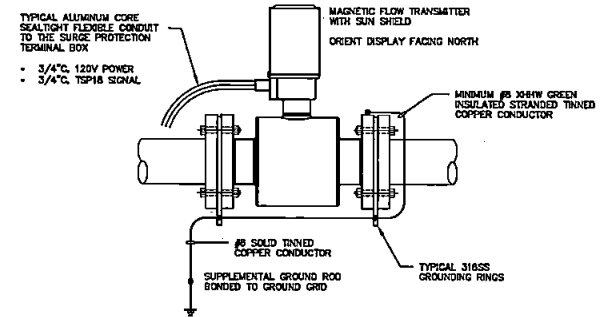

TYPICAL MAGNETIC FLOW METER DETAIL
NOT TO SCALE

NOTES:

1. FLOW TUBE SHALL HAVE A MINIMUM OF 8 STRAIGHT PIPE DIAMETERS UPSTREAM AND 2 STRAIGHT PIPE DIAMETERS DOWNSTREAM.
2. PROVIDE GROUNDING RINGS (BOTH SIDES).

NO.	BY	DATE	SYMBOL	REVISIONS

M M Moff MacDonald Florida, LLC	Architects Engineers Surveyors AA - C0000035 EB - 0000155 LB - 0000783 18245 Conurbation Pkwy., N., Suite 320 Jacksonville, Florida 32225 Telephone: (904) 253-1000	DESIGNER: W. DASSETTER DRAWN BY: S. LEE DATE: JAN 2022 CHECKED BY: A. GIBBS DATE: JAN 2022	DESIGN ENGINEER W. DAVID LASSETTER, P.E. FLORIDA REGISTRATION NO. 37971 3507 Buckskin Trail E Jacksonville, FL 32227 904-743-1595		St. Johns County Utility Department 1206 STATE ROAD 18 ST. AUGUSTINE, FL 32084 PHONE: (904) 209-0028 FAX: (904) 209-2827	SAWGRASS WWTP - EXISTING MASTER LIFT STATION AND PIPING IMPROVEMENTS	ELECTRICAL DETAILS	SHEET NO. DRAWING ED-1 100% SUBMITTAL
---	---	--	--	--	--	--	--------------------	--



St. Johns County Board of County Commissioners

Utility Department

January 31, 2022

RE: WSI Continuing Contract Task Order for Sawgrass Influent PS Improvements and Bypass Piping Installation

The Sawgrass WWTP Facility is in need of decommissioning as soon as possible due to deteriorating conditions of various pieces of equipment and on-going costs to maintain reliable operability. As such, numerous projects have been in construction to complete the final tie-ins of the Sawgrass WWTF to the new Players Club WRF.

Current construction of the interconnect of the wastewater and reclaimed water pipelines from the Players Club Property south along A1A to the Sawgrass WWTP is expected to be completed in May/June 2022. A change order was issued to that pipeline contractor to complete the additional interior pipelines at the Sawgrass Facility to the Influent Pump Station to expedite that process.

As the design of the Influent PS was being completed, every effort has been made to complete the transfer of flows to Players Club WRF by June 2022. The Utility went through the current continuing contract contractors to expedite the process and use a reliable, quality contractor to complete the construction within schedule noted above.

Wharton Smith, Inc. has been a proven contractor that can expedite construction and meet tight deadlines. They have worked with the Utility on several major projects and provided a construction cost estimate for this project that is reasonable and within the budget allotted. The Utility requests an approval of the Task Order from the Board to meet the expedited schedule and provide the best value to the Utility.

Projected Schedule:

BOCC Meeting:	March 1, 2022
Execute Task Order:	2 weeks
Notice to Proceed:	March 18, 2022
Material Procurement:	2-4 weeks
Project Duration:	9 weeks
Project Completion:	June 2022



**CONTINUING CONSTRUCTION CONTRACT AGREEMENT
BETWEEN COUNTY AND CONTRACTOR
(2012 EDITION)
MASTER CONTRACT #: 18-MCC-WHA-08956**

This Contract Agreement ("Agreement") is made and entered into as of this 21st day of January, 2018, by and between **St. Johns County, FL** ("County"), a political subdivision of the State of Florida, whose principal offices are located at 500 San Sebastian View, St. Augustine, Florida, 32084, and **Wharton-Smith, Inc**, ("Contractor"), a company authorized to do business in the State of Florida, with offices located at 750 Monroe Road, Sanford, FL 32771; Phone: (407) 321-8410; Email: nhillard@whartonsmith.com; under seal for **RFP No: 18-22, Utility Rehabilitation/Construction Services**. In consideration of the mutual promises and covenants contained herein, the parties hereby agree as follows.

ARTICLE I – THE CONTRACT AND THE CONTRACT DOCUMENTS

1.1 The Contract and Contract Documents

- 1.1.1 The Contract between the County and the Contractor, of which this Agreement is a part, shall consist of the Contract Documents.
- 1.1.2 The Contract Documents shall consist of: (1) this Agreement together with all exhibits, attachments, and duly executed amendments; (2) all RFP No: 18-22 documents together with all addenda thereto; (3) all Specifications; (4) all duly executed Amendments, Task Orders, Change Orders and Field Orders issued after the Effective Date of the Contract; and (5) FEMA Public Assistance Program Required Contract Clauses (Exhibit B). Documents not enumerated in this Article are not Contract Documents and do not form part of the Contract.

1.2 Contract Term and Extension

- 1.2.1 Unless terminated or extended in accordance with other provisions contained herein, the initial term of the Contract shall begin on the date of signature by the County ("Effective Date"), and shall remain in effect for a period of three (3) calendar years.
- 1.2.2 The term of the Contract may be renewed for up to one (1) additional two (2) year periods, contingent upon satisfactory performance by the Contractor, mutual written agreement by both parties, and the availability of funds. While the Contract may be renewed as provided herein, it is expressly noted that the County is under no obligation to renew or extend the Contract. It is further expressly noted that the option of renewing the Contract is exercisable only by the County, and only upon the County's determination that the Contractor has satisfactorily performed under the terms of the Contract. The County reserves the right to further extend the Contract, as necessary, to complete any ongoing projects, or as best serves the needs of the County.

1.3 Entire Agreement

- 1.3.1 The Contract, together with the Contractor's Public Construction Bond(s) (as applicable), and Certificates of Insurance constitutes the entire agreement between the County and the Contractor with reference to RFP No: 18-22; Utility Rehabilitation/Construction Services. Specifically, but without limitation, the Contract supersedes any RFP Document not listed among the Contract Documents described herein and all prior written and/or oral communications, representations and negotiations, if any, between County and Contractor.

1.4 No Privity with Others

- 1.4.1 Nothing contained in the Contract shall create, or be interpreted to create privity or any other contractual agreement between County and any person or entity other than the Contractor.

1.5 Intent and Interpretation

- 1.5.1 The intent of the Contract is to require complete, correct and timely execution of the Work. Any work that may be required, implied, or inferred by the Contract Documents, or any one or more of them, as necessary to produce the intended result shall be provided by the Contractor for the Project Price as provided by Task Order.
- 1.5.2 The Contract is intended to be an integral whole and shall be interpreted as internally consistent. What is required by any one Contract Document shall be considered as required by the Contract.

- 1.5.3 When a word, term or phrase is used in the Contract, it shall be interpreted or construed, first, as defined herein; second, if not defined, according to its generally accepted meaning in the construction industry; and third, if there is no generally accepted meaning in the construction industry, according to its common and customary usage.
- 1.5.4 The words "include," "includes" or "including," as used in the Contract, shall be deemed to be followed by the phrase "without limitation."
- 1.5.5 The specification herein of any act, failure, refusal, omission, event, occurrence, or condition as constituting a material breach of the Contract shall not imply that any other, non-specified act, failure, refusal, omission, event, occurrence, or condition shall be deemed not to constitute a material breach of the Contract.
- 1.5.6 Words or terms used as nouns in the Contract shall be inclusive of their singular and plural forms, unless the context of their usage clearly requires a contrary meaning.
- 1.5.7 The headings, titles and captions contained herein are inserted for convenience only and in no way are intended to interpret, define, or limit the scope, extent, or intent of the Contract or any provision thereof.
- 1.5.8 The Contractor shall have a continuing duty to read, carefully study and compare each of the Contract Documents, the Shop Drawings and the Product Data and shall give written notice to the County of any inconsistency, ambiguity, error or omission which the Contractor may discover with respect to these documents before proceeding with the affected Work. The issuance or the express or implied approval by the County of the Contract Documents, Shop Drawings, or Product Data shall not relieve Contractor of the continuing duty set forth in this paragraph. The County has requested that the Project Manager only oversee preparation of documents for the Work, including the Drawings and Specifications for the Work, which are accurate, adequate, consistent, coordinated, and sufficient for construction. HOWEVER, THE COUNTY MAKES NO REPRESENTATION OR WARRANTY OF ANY NATURE WHATSOEVER TO THE CONTRACTOR CONCERNING SUCH DOCUMENTS. By the execution hereof, the Contractor acknowledges and represents that it has received, reviewed and carefully examined such documents, has found them to be complete, accurate, adequate, consistent, coordinated and sufficient for construction. The Contractor further acknowledges that it has not, does not, and shall not rely upon any representation or warranties by the County concerning such documents as no such representation or warranties have been or are hereby made.
- 1.5.9 As between numbers and scaled measurements on the Drawings and in the Design, the numbers shall govern; as between larger scale and smaller scale drawings, the larger scale shall govern.
- 1.5.10 Neither the organization of any of the Contract Documents into divisions, sections, paragraphs, articles, (or other categories), nor the organization or arrangement of the Design, shall control the Contractor in dividing the Work or in establishing the extent or Scope of Work to be performed by Subcontractors.
- 1.6 Ownership of Contract Documents
 - 1.6.1 The Contract Documents, and each of them, shall remain the property of the County. The Contractor shall have the right to keep one record set of the Contract Documents upon completion of the Work; provided, however, that in no event shall the Contractor use, or permit to be used, any or all of such Contract Documents on other projects without County's prior written authorization.

ARTICLE II – THE WORK

- 2.1 The Contractor shall perform all of the Work required, implied, or reasonably inferable from the Contract.
- 2.2 The term "Work" shall mean whatever is done by or required of the Contractor to perform and complete its duties under the Contract, including the following: construction of the whole or a designated part of a project as set forth each Task Order; furnishing of any required Surety Bonds and insurance; and the provision or furnishing of labor, supervision, services, materials, supplies, equipment, fixtures, appliances, facilities, tools, transportation, storage, power, permits and licenses required of the Contractor, fuel, heat, light, cooling and all other utilities as required by the Contract. The Work to be performed by the Contractor on each project shall be specifically described in, and authorized by Task Order issued by the County. Each Task Order issued by the County under the Contract shall further specify the amount of time permitted for completion of the Work ("Project Time") and the amount to be paid as compensation for completion of Work ("Project Price").

ARTICLE III – PROJECT TIME

- 3.1 Time and Liquidated Damages

Contractor shall commence the Work for each project upon receipt of a Notice to Proceed, or as stated on the executed Task Order, issued by the County, and shall reach Substantial and Final Completion of all Work as specified by Task Order.

For each project, the number of calendar days from the date on which the Work is permitted to proceed through the date set forth in the Task Order for Final Completion shall constitute the "Project Time."

3.1.2 For each project, the Contractor shall pay the County the sum of nine hundred fifty eight dollars (\$958.00), based on the FDOT Table provided in the RFP Document for each and every calendar day of unexcused delay in achieving Substantial Completion of the Work beyond the date specified by Task Order for Substantial Completion of the Work. Any sums due and payable hereunder by the Contractor shall be payable, not as a penalty, but as liquidated damages representing an estimate of delay damages likely to be sustained by the County, estimated at or before the time of issuing the Task Order. When the County reasonably believes that Substantial Completion shall be inexcusably delayed the County shall be entitled, but not required, to withhold from any amounts otherwise due the Contractor an amount then believed by the County to be adequate to recover liquidated damages applicable to such delays. If and when the Contractor overcomes the delay in achieving Substantial Completion, or any part thereof, for which the County has withheld payment, the County shall promptly release to the Contractor those funds withheld, but no longer applicable, as liquidated damages.

3.2 Substantial Completion

3.2.1 "Substantial Completion" shall mean that stage in the progression of the Work when the Work is sufficiently complete as provided by Task Order that the County can enjoy beneficial use or occupancy of the Work and can utilize the Work for its intended purpose.

3.3 Time is of the Essence

3.3.1 All limitations of time set forth in the Contract Documents are of the essence of this Contract.

ARTICLE IV – PROJECT PRICE

4.1 The Project Price

4.1.1 The County shall pay, and the Contractor shall accept, as full and complete payment for all Work required by each Task Order, the amount specified and authorized by each Task Order upon completion of the Work for each project. The amount set forth in each Task Order shall not exceed two hundred thousand dollars (\$200,000), without prior written authorization by the County Administrator or authorized designee. No Task Order will be issued for over \$200,000.00 unless approved by the Board of County Commissioners.

ARTICLE V – PAYMENT OF THE PROJECT PRICE

5.1 Schedule of Values

5.1.1 Upon request by the County, the Contractor shall submit a Schedule of Values allocating the Project Price to the various portions of the Work included in the Task Order for each project. The Contractor's Schedule of Values shall be prepared in such form, with such detail, and supported by such data as the County may require, in order to substantiate its accuracy. The Contractor shall not imbalance its Schedule of Values, nor artificially inflate any element thereof. The violation of this provision by the Contractor shall constitute a material breach of the Contract. The Schedule of Values shall be used only as a basis for the Contractor's Requests for Payment and shall only constitute such basis after it has been agreed upon in writing by the County.

5.2 Payment Procedure

5.2.1 The County shall pay the Project Price to the Contractor as provided below.

5.2.2 Progress Payments - Based upon the Contractor's Requests for Payment submitted to the County and upon Certificates for Payment subsequently issued to the County by the Project Manager, the County shall make progress payments to the Contractor on account of the Project Price. Retainage in the amount of ten percent (10%) will be withheld from each progress payment until County has issued Final Acceptance of the Work. Progress payments for each project shall be provided by Task Order.

5.2.3 On or before the fifteenth (15th) day of each month after commencement of the Work for each project, the Contractor shall submit an Application for Payment for the period ending the thirtieth (30th) day of the previous month to the Project Manager in such form and manner, and with such supporting data and content, as the Project

er may require. Therein, the Contractor may request payment for ninety percent (90%) of that portion of Project Price properly incorporated in the Work less the total amount of previous payments received from the County.

Such Application for Payment shall be signed by the Contractor and shall constitute the Contractor's representation that the Work has progressed to the level for which payment is requested, that the Work has been properly installed or performed in full accordance with the Contract Documents, and that the Contractor knows of no reason why payment should not be made as requested. Thereafter, the Project Manager (and Engineer if applicable) shall review the Application for Payment and may also review the Work at the project site or elsewhere to determine whether the quantity and quality of the Work is as represented in the Application for Payment and is as required by the Contract Documents. The Project Manager shall determine and certify to the County the amount properly owing to the Contractor. The County shall make partial payments on accounts of the Project Price within thirty (30) days following the Project Manager's receipt of each Application for Payment. The amount of each partial payment shall be the amount certified for payment by the Project Manager less such amounts, if any, otherwise owing by the Contractor to the County or which the County shall have the right to withhold as authorized by the Contract. The Project Manager's certification of the Contractor's Application for Payment shall not preclude the County from the exercise of any of its rights as set forth in Paragraph 5.3 herein below.

5.2.4 The Contractor warrants that title to all Work covered by an Application shall pass to the County no later than time of payment. The Contractor further warrants that upon submittal of an Application for Payment, all Work for which payments have been received from the County shall be free and clear of liens, claims, security interest or other encumbrances in favor of the Contractor or any other person or entity whatsoever.

5.2.5 The Contractor shall promptly pay each Subcontractor out of the amount paid to the Contractor on account of such Subcontractor's Work, the amount to which such Subcontractor is entitled. In the event the County becomes informed that the Contractor has not paid a Subcontractor as herein provided, the County shall have the right, but not the duty or obligation, to issue future checks in payment to the Contractor of amounts otherwise due hereunder naming the Contractor and such Subcontractor as joint payees. Such joint check procedure, if employed by the County, shall create no rights in favor of any person or entity beyond the right of the named payees to payment of the check and shall not be deemed to commit the County to repeat the procedure in the future.

5.2.6 No progress payment, nor any use or occupancy of any project by the County, shall be interpreted to constitute an acceptance of any Work not in strict accordance with the Contract Documents.

5.3 Withheld Payment

5.3.1 County may decline to make payment, may withhold funds and, if necessary, may demand the return of some or all of the amounts previously paid to the Contractor, to protect the County from loss because of:

- (1) defective Work not remedied by the Contractor and, in the opinion of the County, not likely to be remedied by the Contractor;
- (2) claims of third parties against the County or the County's property;
- (3) failure by the Contractor to pay Subcontractors or others in a prompt and proper fashion;
- (4) evidence that the balance of the Work cannot be completed in accordance with the Task Order for unpaid balance of the Project Price;
- (5) evidence that the Work shall not be completed in the time required for Substantial or Final Completion of the Work;
- (6) repeated failure (two or more times) to carry out the Work as specified by Task Order;
- (7) damage to the County or a third party to whom the County is, or may be, liable;
- (8) failure by the Contractor to timely pay, any, and all, applicable taxes, fees (including permit or use fees), costs, or expenses, associated with the Project.

In the event that the County makes written demand upon the Contractor for amounts previously paid by the County as contemplated in this Subparagraph 5.3.1, the Contractor shall promptly comply with such demand.

5.4 Unexcused Failure to Pay

5.4.1 If within ten (10) days after the date established by Task Order for payment to the Contractor by the County, the County, without cause or basis hereunder, fails to pay the Contractor any amount due and payable to the Contractor, then the Contractor may after seven (7) additional days, written notice to the County and the Project

Manager, and without prejudice to any other available rights or remedies it may have, stop the Work until payment of those amounts due from the County have been received. Any payment not made within ten (10) days after the date due shall bear interest at the rate of twelve percent (12%) per annum.

5.5 Substantial Completion

5.5.1 When the Contractor believes the Work required by Task Order for each project is Substantially Complete, the Contractor shall submit to the Project Manager a list of items to be completed or corrected. When the Project Manager on the basis of an inspection determines that the Work is in fact Substantially Complete, the Project Manager shall prepare a Certificate of Substantial Completion which shall establish the date of Substantial Completion of the Work, shall state the responsibilities of the County and the Contractor for project security, maintenance, heat, utilities, damage to the Work, and insurance, and shall fix the time within which the Contractor shall complete the items listed therein. Guarantees required by the Contract Documents shall commence on the date of Substantial Completion of the Work. The Certificate of Substantial Completion shall be submitted to the County and the Contractor for their written acceptance of the responsibilities assigned to them in such certificate.

Until Final Completion and acceptance of the Work by the County, the County shall pay the Contractor an amount equal to ninety percent (90%) of the Project Price. Ten Percent (10%) of the Project Price shall be retained until Final Completion, acceptance of the Work by the County and Final Payment to the Contractor.

5.6 Final Completion and Final Payment

5.6.1 When all the Work required by Task Order for each project is finally complete and the Contractor is ready for a Final Inspection, it shall notify the County and the Project Manager thereof in writing. Thereupon, the Project Manager shall make Final Inspection of the Work and, if the Work is complete in full accordance with the project Task Order and the Task Order has been fully performed, the Project Manager shall promptly issue a Final Certificate for Payment for the project and if required to repeat its Final Inspection of the Work, the Contractor shall bear the cost of such repetition of the Work, the Contractor shall bear the cost of such repeat Final Inspection(s) which cost may be deducted by the County and all other Authorities having jurisdiction under Florida Laws or regulations.

5.6.1.1 If the Contractor fails to achieve Final Completion within the time fixed in the Certificate of Substantial Completion, the Contractor shall pay the County liquidated damages at the sum shown in Paragraph 3.1.2, per day for each and every calendar day of unexcused delay in achieving Final Completion beyond the date set forth for Final Completion of the Work. Any sums due and payable hereunder by the Contractor shall be payable, not as penalty, but as liquidated damages representing an estimate of delay damages likely to be sustained by the County, estimated at or before the time of issuance of the Task Order. When the County reasonably believes that Final Completion shall be inexcusably delayed, the County shall be entitled, but not required, to withhold from any amounts otherwise due the Contractor an amount then believed by the County to be adequate to recover liquidated damages applicable to such delays. If and when the Contractor overcomes the delay in achieving Final Completion, or any part thereof, for which the County has withheld payment, the County shall promptly release to the Contractor those funds withheld, but no longer applicable, as liquidated damages.

5.6.2 The Contractor shall not be entitled to Final Payment unless and until it submits to the Project Manager its affidavit that all payrolls, invoices for materials and equipment, and other liabilities connected with the Work on each project for which the County, or the County's property might be responsible, have been fully paid or otherwise satisfied; releases and waivers of claims and lien from all Subcontractors of the Contractor and of any and all other parties required by the County; consent of Surety, if any, to Final Payment. If any third party fails or refuses to provide a release of claim or waiver of a lien as required by County the Contractor shall furnish a bond satisfactory to the County to discharge any such lien or indemnify the County from liability.

5.6.3 The County shall make Final Payment of all sums, due the Contractor within thirty (30) days of the Project Manager's execution of a Final Certificate for Payment.

5.6.4. Acceptance of Final Payment shall constitute a waiver of all claims against the County by the Contractor except for those claims previously made in writing against the County by the Contractor, pending at the time of Final Payment, and identified in writing by the Contractor as unsettled at the time of its request for Final Payment.

ARTICLE VI – THE COUNTY

6.1 Information, Services and Things Required from County

- 6.1.1 The County shall furnish to the Contractor, at the time of issuing each Task Order, any and all written and tangible material in its possession concerning conditions below ground at the site of the project. Such written and tangible material is furnished to the Contractor only in order to make complete disclosure of such material and for no other purpose. By furnishing such material, the County does not represent, warrant, or guarantee its accuracy either in whole, in part, implicitly, or at all, and shall have no liability therefore. The County shall also furnish surveys, legal limitations and utility locations (if known), and a legal description of the project site. Copies may be provided instead of originals.
- 6.1.2 Excluding permits and fees normally the responsibility of the Contractor, the County shall obtain all approvals, easements, and the like required for construction.
- 6.1.3 The County shall furnish the Contractor, free of charge, three (3) copies of the Contract Documents for execution of the Work. The Contractor shall be charged, and shall pay the actual cost of reproduction per additional set of Contract Documents which it may require.
- 6.2 Right to Stop Work
 - 6.2.1 If the Contractor persistently fails or refuses to perform Work in accordance with any Task Order, the County may order the Contractor to stop the Work, or any described portion thereof, until the cause for stoppage has been corrected, no longer exists, or the County orders that Work be resumed. In such event, the Contractor shall immediately obey such order. Further, the Contractor shall not be paid for, nor make any claim for payment for, any Work done in connection with the Project, during the period of Work stoppage.
- 6.3 County's Right to Perform Work
 - 6.3.1 If the Contractor's Work is stopped by the County under Paragraph 6.2, and the Contractor fails within seven (7) days of such stoppage to provide adequate assurance to the County that the cause of such stoppage shall be eliminated or corrected, the County may, without prejudice to any other rights or remedies the County may have against the Contractor, proceed to carry out the subject Work.

In such a situation, an appropriate Change Order shall be issued by the County deducting from the Project Price the cost of correcting the subject deficiencies, and compensation for the County's additional services and expenses necessitated thereby, if any. If the unpaid portion of the Project Price is insufficient to cover the amount due the County, the Contractor shall pay the difference to the County.

ARTICLE VII – THE CONTRACTOR

- 7.1 The Contractor is again reminded of its continuing duty set forth in Subparagraph 1.5.7. The Contractor shall perform no part of the Work at any time without adequate Contract Documents or, as appropriate, approved Shop Drawings, Product Data or Samples for such portion of the Work. If the Contractor performs any of the Work where Contractor knows or should know such Work involves a recognized error, inconsistency or omission in the Contract Documents without such notice to the Project Manager and the County, the Contractor shall bear responsibility for such performance and shall bear the cost of correction.
- 7.2 The Contractor shall perform the Work for each project strictly in accordance with the Contract Documents.
- 7.3 The Contractor shall supervise and direct the Work for each project using the Contractor's best skill, effort and attention. The Contractor shall be responsible to the County for any and all acts or omissions of the Contractor, its employees and other engaged in the Work on behalf of the Contractor.
- 7.4 Warranty
 - 7.4.1 The Contractor warrants to the County that all labor furnished to progress the Work under the Contract shall be competent to perform the tasks undertaken, that the product of such labor shall meet or exceed acceptable industry standards, that materials and equipment furnished shall be of good quality, free from faults and defects and in strict conformance with the Contract. This warranty shall survive termination of the Contract and shall not be affected by Final Payment for any project hereunder. All Work not conforming to these requirements may be considered defective.
- 7.5 Contractor shall obtain and pay for all permits, fees and licenses necessary and ordinary for the Work. The Contractor shall comply with all lawful requirements applicable to the Work and shall give and maintain any and all notices required by applicable law pertaining to the Work.
- 7.6 Supervision

7.6.1 The Contractor shall employ and maintain at each project site only competent supervisory personnel. Absent written instruction from the Contractor to the contrary, the superintendent shall be deemed the Contractor's authorized representative at the site and shall be authorized to receive and accept any and all communications from the County or Assignees.

7.6.2 Key supervisory personnel assigned by the Contractor to projects under the Contract are as follows:

Name	Function
<u>Robert Lightsey</u>	<u>Project Superintendent</u>
<u>Matthew Peterson</u>	<u>Project Manager</u>
<u>Curtis Matte</u>	<u>Project Manager</u>

So long as the individuals named above remain actively employed or retained by the Contractor, they shall perform the functions indicated next to their names unless the County agrees to the contrary in writing. In the event one or more individuals not listed above subsequently assume one or more of those functions listed above, the Contractor shall be bound by the provisions of this Subparagraph 7.6.2 as though such individuals have been listed above.

7.7 The Contractor, prior to commencing the Work for each project, shall submit to the Project Manager for his information, the Contractor's schedule for completing the Work. The Contractor's schedule shall be revised no less frequently than monthly (unless the parties otherwise agree in writing) and shall be revised to reflect conditions encountered from time to time and shall be related to each entire project. Each sum revision shall be furnished to the Project Manager. Failure by the Contractor to strictly comply with the provisions of this Paragraph 7.7 shall constitute a material breach of the Contract.

7.8 The Contractor shall continuously maintain at the project site, for the benefit of the Project Manager, one record copy of the Contract and the project Task Order marked to record on a current basis changes, selections and modifications made during construction. Additionally, the Contractor shall maintain at the project site for the Project Manager the approved Product Data, Samples and other similar required submittals. For each project, upon Final Completion of the Work, such record documents shall be delivered to the County.

7.9 Product Data and Samples

7.9.1 Product Data, Samples and other submittals from the Contractor do not constitute Contract Documents. Their purpose is merely to demonstrate the manner in which the Contractor intends to implement the Work for each project in conformance with the information received from the Contract Documents. All Product Data, Samples and other submittals shall belong to the County and shall be delivered, or returned to County, as applicable, prior to Submittals shall belong to County and shall be delivered, or returned to County, as applicable, prior to Substantial Completion.

7.10 Cleaning the Site and the Project

7.10.1 The Contractor shall keep each project site reasonably clean during performance of the Work. Upon Final Completion of the Work, the Contractor shall clean the site and the project and remove all waste, together with all of the Contractor's property there from.

7.11 Access to Work

7.11.1 The County and the Project Manager shall have access to the Work at all times from commencement of the Work through Final Completion. The Contractor shall take whatever steps necessary to provide access when requested.

7.12 Indemnity

7.12.1 To the fullest extent permitted by law, for each project, the Contractor shall indemnify and hold harmless the County, its officers and employees from, and against, any, and all, administrative/legal/equitable liability, claims, damages, losses and expenses, including attorneys' fees, arising out of or resulting from performance of the Work noted in the Contract Documents, that are referenced and considered a part of the Contract. It is specifically noted that such liability, claims, damages, loss or expense includes any of those referenced instances attributable to bodily injury, sickness, disease, or death, or to injury to, or destruction of, personal and/or real property, including

the loss of use resulting there from or incident to, connected with, associated with or growing out of direct and/or indirect negligent or intentional acts or omissions by the Contractor, a Subcontractor, or anyone directly, or indirectly employed by them, or anyone for whose acts the Contractor or Subcontractor may be liable, regardless of whether or not such liability, claim, damage, loss or expense is caused in part by a party indemnified hereunder.

7.12.2 In claims against any person or entity indemnified under this Paragraph 7.12 by an employee of the Contractor, a Subcontractor, any one directly or indirectly employed by them or anyone for whose acts they may be liable, the indemnification obligation under this Paragraph 7.12 shall not be limited by a limitation on amount or type of damages, compensation or benefits payable by or for the Contractor or a Subcontractor under workers' compensation acts, disability benefits acts or other employee benefit acts.

7.13 Safety

7.13.1 The Contractor shall be responsible for supervising all safety precautions, including initiating and maintaining such programs in connection with performance of the Contract and for adequate maintenance of traffic.

7.13.2 The Contractor shall designate a member of the on-site construction team for each Project, whose duty shall be the prevention of accidents. Unless notified otherwise in writing by the Contractor to the County (and the Engineer if applicable), this person shall be the Contractor's Superintendent.

ARTICLE VIII – CONTRACT ADMINISTRATION

8.1 Project Manager

8.1.1 The Project Manager, unless otherwise directed by the County shall perform those duties and discharge those responsibilities allocated to the Project Manager as set forth in the Contract. The Project Manager shall be the County's representative for the entire Term of the Contract. The Project Manager shall be authorized to act on behalf of the County only to the extent provided in the Contract.

8.1.2 The County and the Contractor shall communicate with each other in the first instance through the Project Manager.

8.1.3 The Project Manager shall be the initial interpreter of the requirements of the drawings and specifications and the judge of the performance thereunder by the Contractor. The Project Manager shall render written or graphic interpretations as necessary for the proper execution or progress of the Work with reasonable promptness on request of the Contractor.

8.1.4 The Project Manager shall review the Contractor's Applications for Payment and shall certify to the County for payment to the Contractor, those amounts then due to the Contractor as provided in the Contract Documents.

8.1.5 The Project Manager shall have authority to reject Work, which is defective or does not conform to the requirements of the Contract Documents. If the Project Manager deems it necessary or advisable, the Project Manager shall have authority to require additional inspection or testing of the Work for compliance with Contract requirements at Contractor's expense.

8.1.6 The Project Manager shall review and approve, or take other appropriate action as necessary, concerning the Contractor's submittals including Product Data and Samples. Such review, approval or other action shall be for the sole purpose of determining conformance with the design concept and information given through the Contract Documents.

8.1.7 The Project Manager shall prepare Change Orders for processing by the Purchasing Department and may authorize minor changes in the Work by Field Order as provided elsewhere herein.

8.1.8 The Project Manager shall, upon written request from the Contractor, conduct inspections to determine the date of Substantial Completion and the date of Final Completion, shall receive and forward to the County for the County's review and records, written warranties and related documents required by the Contract and shall issue a Final Certificate for Payment upon compliance with the requirements of the Contract Documents.

8.1.9 The Project Manager's decision in matters relating to visual quality shall be final if consistent with the applicable provisions of the Contract Documents.

8.2 Claims by the Contractor

- 8.2.1 All Contractor claims shall be initiated by written notice and claim to the Project Manager. Such written notice and claims must be furnished within seven (7) days after occurrence of the event, or the first appearance of the condition, giving rise to the claim.
- 8.2.2 Pending final resolution of any claim of the Contractor, the Contractor shall diligently proceed with performance of the Work and the County shall continue to make payments to the Contractor in accordance with each Task Order. The resolution of any claim under this Paragraph 8.2 shall be reflected by a Change Order executed by the Project Manager and the Contractor.
- 8.2.3 Claims for Concealed and Unknown Conditions. Should concealed and unknown conditions encountered in the performance of the Work (a) below the surface of the ground or (b) in an existing structure be at variance with the conditions indicated by Task Order, or should unknown conditions of an usual nature differing materially from those ordinarily encountered in the area and generally recognized as inherent in Work of the character provided for in the Task Order, be encountered, wherein the Contract Documents or Standard Construction industry practices have not placed the responsibility of discovering such concealed and unknown conditions upon the Contractor prior to the Contractor submitting his Pricing Proposal for the Work, the Project Price shall be equitably adjusted by Change Order upon the written notice and claim by either party made within seven (7) days after the first observance of the condition. As a condition precedent to the County having any liability to the Contractor for concealed or unknown conditions, the Contractor must give the Project Manager written notice of, and an opportunity to observe, the condition prior to disturbing it. The failure by the Contractor to make the written notice and claim as provided in this Subparagraph shall constitute a waiver by the Contractor of any claim arising out of or relating to such concealed or unknown condition.
- 8.2.4 Claims for Additional Costs. If the Contractor wishes to make a claim for an increase in the Project Price, as a condition precedent to any liability of the County therefore, the Contractor shall give the Project Manager written notice of such claim within seven (7) days after the occurrence of the event, or the first appearance of the condition, giving rise to such claim. Such notice shall be given by the Contractor before proceeding to execute any additional or changed Work. The failure by the Contractor to give such notice prior to executing the Work shall constitute a waiver of any claim for additional compensation.
- 8.2.4.1 In connection with any claim by the Contractor against the County for compensation in excess of the Project Price, any liability of the County for the Contractor's costs shall be strictly limited to direct costs incurred by the Contractor and shall in no event include indirect costs or consequential damages of the Contractor.
- The County shall not be liable to the Contractor for claims of third parties, including Subcontractors, unless and until liability of the Contractor has been established therefore in a court of competent jurisdiction.
- 8.2.5 Claims for Additional Time. If the Contractor is delayed in progressing any Work which at the time of the delay is then critical or which during the delay becomes critical, as the sole result of any act or neglect to act by the County or someone acting on the County's behalf, or by changes ordered in the Work, unusual delay in transportation, unusually adverse weather conditions not reasonably anticipated, fire or any causes beyond the Contractor's control, then the date for achieving Substantial Completion of the Work shall be extended upon the written notice and claim of the Contractor to the Project Manager, for such reasonable time as the Project Manager may determine.
- Any notice and claims for an extension of time by the Contractor shall be made not more than seven (7) days after the occurrence of the event or the first appearance of the condition giving the rise to the claim and shall set forth in detail the Contractor's basis for requiring additional time in which to complete the project. In the event the delay to the Contractor is a continuing one, only one notice and claim for additional time shall be necessary. If the Contractor fails to make such claim for an extension of time as provided herein, then such claim shall be waived. This paragraph shall not be deemed to waive any damages for delay that are covered by insurance.
- 8.2.5.1 Delays and Extensions of Time. An extension of Project Time shall not be given due to weather conditions unless such weather conditions are more severe than average and have caused a delay. In requesting an extension of time for weather conditions, Contractor shall present complete records and such requests shall document how weather conditions delayed progress of the Work.
- 8.3 Field Orders
- 8.3.1 For each Project, the Project Manager shall have authority to order minor changes in the Work not involving a change in the Project Price or in Project Time and not inconsistent with the intent of the Contract. Such changes

shall be effected by Field Order and shall be binding upon the Contractor. The Contractor shall carry out such Field Orders promptly.

ARTICLE IX – SUBCONTRACTORS

9.1 Definition

9.1.1 A Subcontractor is an entity, which has a direct Contract with the Contractor to perform a portion of the Work.

9.2 Award of Subcontracts

9.2.1 Prior to commencing the Work for each project, the Contractor shall furnish the Project Manager, in writing, the names of persons or entities proposed by the Contractor to act as a Subcontractor on the project. The Project Manager shall reply within seven (7) business days to the Contractor, in writing, stating any objections the Project Manager may have to such proposed Subcontractor. The Contractor shall not enter into a Subcontract with a proposed Subcontractor with reference to whom the Project Manager has made a timely objection.

9.2.2 All subcontracts shall afford the Contractor rights against the Subcontractor, which correspond to those rights afforded to the County by Subparagraph 12.2.1 below.

ARTICLE X – CHANGES IN THE WORK

10.1 Changes Permitted

10.1.1 Changes in the Work within the general scope of each Task Order, consisting of additions, deletions, revisions, or any combination thereof, may be ordered without invalidating the Contract by properly executed Change or Field Order.

10.1.2 Changes in the Work for each project shall be performed under applicable provisions of the Contract and the Contractor shall proceed promptly with such changes.

10.2 Change Order Defined

10.2.1 The term "Change Order" shall mean a written order to the Contractor executed by the County Administrator, or authorized designee, issued after execution of the Contract, authorizing and directing a change in the Work or an adjustment in the Project Price or the Project Time, or any combination thereof. Only a duly executed Change Order may change the Scope of Work, Project Price and/or the Project Time.

10.3 Changes in the Project Price

10.3.1 Any change in the Project Price resulting from a Change Order shall be determined as follows: (a) by mutual agreement between the County and the Contractor as evidenced by (1) the change in the Project Price being set forth in the Change Order, (2) such change in the Project Price, together with any conditions or requirements related thereto, being initialed by both parties and (3) the Contractor's execution of the Change Order, or (b) if no mutual agreement occurs between the County and the Contractor, then, as provided in Subparagraph 10.3.2 below.

10.3.2 If no mutual agreement occurs between the County and the Contractor as contemplated in Subparagraph 10.3.1 above, the change in the Project Price, if any, shall then be determined by the Project Manager on the basis of the reasonable expenditures or savings of those performing, deleting or revising the Work attributable to the change, including, in the case of an increase or decrease in the Project Price, a reasonable allowance for direct project site overhead and profit. In such case, the Contractor shall present, in such form and with such content as the County or the Project Manager requires, an itemized accounting of such expenditures or savings shall be limited to the following: reasonable costs of materials, supplies, or equipment including delivery costs, reasonable costs of labor, including social security, old age and unemployment insurance, fringe benefits required by a pre-existing agreement or by custom, and workers' compensation insurance, reasonable costs of premiums for all Bonds and insurance, permit fees, and sales, use or other taxes related to the Work and paid by the Contractor, and reasonable costs of directly attributable to the change. In no event shall any expenditure or savings associated with the Contractor's home office or other non-project site overhead expenses be included in any change in the Project Price. Pending final determination of reasonable expenditures or savings to the County, payments on account shall be made to the Contractor on the County's Certificate of Payment.

- 10.3.3 If Unit Prices are provided in a Task Order, and if the quantities contemplated are so changed by proposed Change Order that application of such Unit Prices to the quantities of Work proposed shall cause substantial inequity to the County or to the Contractor, then the applicable Unit Prices shall be equitably adjusted.
- 10.4 Minor Changes
- 10.4.1 The Project Manager shall have authority to order minor changes in the Work for each project not involving a change in the Project Price or an extension of the Project Time and not inconsistent with the intent of the Contract. Such minor changes shall be made by written Field Order, and shall be binding upon the County and the Contractor. The Contractor shall promptly carry out such written Field Orders.
- 10.5 Effect of Executed Change Order
- 10.5.1 For each project, the execution of any Change Order by the Contractor shall constitute conclusive evidence of the Contractor's agreement to the ordered changes in the Work, the Contract Documents as thus amended, the Project Price and the Project Time. The Contractor, by executing a Change Order, waives and forever releases any claim against the County for additional time or compensation for matters relating to or arising out of or resulting from the Work included within or affected by the executed Change Order.
- 10.6 Notice to Surety; Consent
- 10.6.1 The Contractor shall notify and obtain the timely consent and approval of the Contractor's surety with reference to all Change Orders if such notice, consent or approval is required by the Contractor's surety or by law. The Contractor's warranty to the County that the surety has been notified of and consents to, such Change Order and the surety shall be conclusively deemed to have been notified of such Change Order and to have expressly consented thereto.

ARTICLE XI – UNCOVERING AND CORRECTING WORK

- 11.1 Uncovering Work
- 11.1.1 If any of the Work for a project is covered contrary to the Project Manager's request or to any provision of the Contract Documents, it shall, if required by the Project Manager, be uncovered for the Project Manager's inspection and shall be properly replaced at the Contractor's expense without change to the Project Time as provided in the Task Order.
- 11.1.2 If any of the Work for a project is covered in a manner not described in Subparagraph 11.1.1 above, it shall, if required by the by the Project Manager or County, be uncovered for the Project Manager's inspection. If such Work conforms strictly to the Contract Documents, costs of uncovering and proper replacement shall by Change Order be charged to the County. If such Work does not strictly conform to the Contract Documents, the Contractor shall pay the costs of uncovering and proper replacement.
- 11.2 Correcting Work
- 11.2.1 The Contractor shall immediately proceed to correct Work rejected by the Project Manager as defective or failing to conform to the Contract Documents. The Contractor shall pay all costs and expenses associated with correcting such rejected Work, including any additional testing and inspections, and reimbursement to the County for the Project Manager's services and expenses made necessary thereby.
- 11.2.2 For each project, if within one (1) year after Substantial Completion of the Work, any of the Work is found to be defective or not in accordance with the Contract Documents, the Contractor shall correct the Work within seven (7) days at the Contractor's expense upon receipt of written notice from the County. This obligation shall survive Final Payment by the County and termination of the Contract. With respect to Work first performed and completed after Substantial Completion of the project, this one (1) year obligation to specifically correct defective and nonconforming Work shall be extended by the period of time which elapses between Substantial Completion and completion of the subject Work.
- 11.2.3 Nothing contained in this Paragraph 11.2 shall establish any period of limitation with respect to other obligations, which the Contractor has under the Contract. Establishment of the one (1) year time period in Subparagraph 11.2.2 relates only to the duty of the Contractor to specifically correct Work for each project, and has no relationship to the time which the obligation to comply with the Contract Documents may be sought to be enforced.
- 11.3 County May Accept Defective or Nonconforming Work

- 11.3.1 If the County chooses to accept any defective or nonconforming Work, the County may do so. In such events, the Project Price shall be reduced by the greater of (a) the reasonable cost of removing and correcting the defective or nonconforming Work, and (b) the difference between the fair market value of the project had it not been constructed in such manner as to include defective or nonconforming Work. If the remaining portion of the unpaid Project Price, if any, is insufficient to compensate the County for its acceptance or defective or nonconforming Work, the Contractor shall, upon written demand from the County, pay the County such remaining compensation for accepting defective or nonconforming Work.

ARTICLE XII – CONTRACT TERMINATION

12.1 Termination by the Contractor

- 12.1.1 For each project, if the Work is stopped for a period of ninety (90) days by an order of any court or as a result of an act of the Government, through no fault of the Contractor or any person or entity working directly or indirectly for the Contractor, the Contractor may, upon ten (10) days written notice to the County, terminate performance under the Contract and recover from the County payment for the actual reasonable expenditures of the Contractor (as limited in Subparagraph 10.3.2 above) for all Work executed and for materials, equipment, tools, construction equipment and machinery actually purchased or rented solely for the Work, less any salvage value of any such items.

- 12.1.2 For each project, if the County shall persistently or repeatedly fail to perform any material obligation to the Contractor for a period of fifteen (15) days after receiving written notice from the Contractor of its intent to terminate if such failure is not substantially corrected within fifteen (15) days, the Contractor may terminate performance under the Contract by written notice to the Project Manager. In such event, the Contractor shall be entitled to recover from the County as though the County had terminated the Contractor's performance under the Contract for convenience pursuant to Subparagraph 12.2.1 hereunder.

12.2 Termination by the County

12.2.1 For Convenience

- 12.2.1.1 The County may terminate the Contract for convenience. In such instance, the County shall provide written notice of such termination to the Contractor specifying when termination shall become effective.

- 12.2.1.2 The Contractor shall incur no further obligations in connection with the Work and the Contractor shall stop Work when such termination becomes effective. The Contractor shall also terminate outstanding orders and subcontracts. The Contractor shall settle liabilities and claims arising out of the termination of subcontracts and orders. The County may direct the Contractor to assign the Contractor's right, title and interest under terminated orders or subcontracts to the County or its designee.

- 12.2.1.3 The Contractor shall transfer title and deliver to the County for such completed or partially completed Work and materials, equipment, parts, fixtures, information and Contract rights as the Contractor has in either its possession or control.

- 12.2.1.4 (a) The Contractor shall submit a termination claim to the Project Manager specifying the amounts due because of the termination for convenience together with costs, pricing or other data required by the Project Manager. If the Contractor fails to file a termination claim within one (1) year from the effective date of termination of the Contract, the County shall pay the Contractor, an amount derived in accordance with subparagraph (c) below.

(b) The County and the Contractor may agree to compensation, if any, due to the Contractor hereunder.

(c) Absent an agreement as to the amount due to the Contractor, the County shall pay the Contractor the following amounts:

(i) Project Prices for labor, materials, equipment, and other services accepted under the Contract;

(ii) Reasonable costs incurred in preparing to perform and in performing a portion of the Work prior to termination and not included in (i) or (ii), and in terminating the Contractor's performance, plus a fair and reasonable allowance for overhead and profit thereon (such profit shall not include anticipated profit or consequential damages); provided, however, that if it appears that the Contractor would have not profited or would have sustained a loss if the entire Contract had been completed, no profit shall

be allowed or included and the amount of compensation shall be reduced to reflect the anticipated rate of loss, if any;

- (iii) Reasonable costs of settling and paying claims arising out of the termination of Subcontracts or orders pursuant to Subparagraph 12.2.1.2 of this Paragraph. These costs shall not include amounts paid in accordance with other provisions hereof.

The total sum to be paid the Contractor under this Subparagraph 12.2.1 shall not exceed the total Project Price, as properly adjusted, reduced by the amount of payments otherwise made, and shall in no event include duplication of payment.

12.2.2 For Cause

12.2.2.1 If the Contractor persistently or repeatedly refuses or fails to perform the Work in a timely manner, supply enough properly skilled Workers, supervisory personnel or proper equipment or materials to complete the Work, or fails to make prompt payment to Subcontractors, or for materials or labor, or persistently disregards laws, ordinances, rules, regulations or orders of any public authority having jurisdiction, or otherwise substantially violates a material provision of the Contract as determined by the County, then the County may, by written notice to the Contractor, without prejudice to any other right or remedy, terminate the Contract and take possession of the project site and of all materials, equipment, tools, construction equipment and machinery thereon owned by the Contractor and may finish the Work by whatever methods it may deem expedient. In such case, the termination of the Contract is effective as of the time that notice of termination is delivered to an authorized representative of the Contractor, or as of the date and time, specified in the notice of termination (whichever is applicable). In such case, the Contractor shall not be entitled to receive any further payment until the Work is completed.

12.2.2.2 If the unpaid balance of the Project Price less any liquidated damages due under the Contract, exceeds the cost of finishing the Work, including compensation for the Project Manager's additional services and expenses made necessary thereby, such exceed the unpaid balance, the Contractor shall pay the difference to the County. This obligation for payment shall survive the termination of the Contract.

12.2.2.3 In the event the Contract is terminated by the County for cause pursuant to Subparagraph 12.2.2 and it is subsequently determined by a Court of competent jurisdiction that such termination was without cause, such termination shall thereupon be deemed a Termination for Convenience under Subparagraph 12.2.1 and the provisions of Subparagraph 12.2.1 shall apply.

ARTICLE XIII – INSURANCE

13.1 Contractor's Insurance

13.1.1 The Contractor shall not commence work under this Contract until he/she has obtained all insurance required under this section and such insurance has been approved by the County. All insurance policies shall be issued by companies authorized to do business under the laws of the State of Florida. The Contractor shall furnish proof of Insurance to the County prior to the commencement of operations. The Certificate(s) shall clearly indicate the Contractor has obtained insurance of the type, amount, and classification as required by contract and that no material change or cancellation of the insurance shall be effective without thirty (30) days prior written notice to the County. Certificates shall specifically include the County as Additional Insured for all lines of coverage except Workers' Compensation and Professional Liability. A copy of the endorsement must accompany the certificate. Compliance with the foregoing requirements shall not relieve the Contractor of its liability and obligations under this Contract.

Certificate Holder Address: St. Johns County, a political subdivision of the State of Florida
500 San Sebastian View
St. Augustine, FL 32084

13.1.1.1 The Contractor shall maintain throughout the life of this Contract, Comprehensive General Liability Insurance with minimum limits of \$1,000,000 per occurrence, \$2,000,000 aggregate to protect the Contractor from claims for damages for bodily injury, including wrongful death, as well as from claims of property damages which may arise from any operations under this Contract, whether such operations be by the Contractor or by anyone directly employed by or contracting with the Contractor.

13.1.1.2 The Contractor shall maintain during the life of the contract, Professional Liability or Errors and Omissions Insurance with minimum limits of \$1,000,000, if applicable.

- 13.1.1.3 The Contractor shall maintain during the life of this Contract, Comprehensive Automobile Liability Insurance with minimum limits of \$2,000,000 combined single limit for bodily injury and property damage liability to protect the Contractor from claims for damages for bodily injury, including the ownership, use, or maintenance of owned and non-owned automobiles, including rented/hired automobiles whether such operations be by the Contractor or by anyone directly or indirectly employed by a Contractor.
- 13.1.1.4 The Contractor shall maintain Umbrella or Excess Liability Insurance covering workers compensation, commercial general liability and business auto liability with minimum limits of liability of \$1,000,000.
- 13.1.1.5 The Contractor shall maintain during the life of this Contract, adequate Workers' Compensation Insurance in at least such amounts as are required by the law for all of its per Florida Statute 440.02.
- 13.1.1.6 In the event of unusual circumstances, the County Administrator, or his designee, may adjust these insurance requirements.
- 13.1.1.7 Contractor shall provide the County at least thirty (30) days prior notice of any cancellation of or modification to any insurance coverage required under the Contract.
- 13.1.1.8 It is the responsibility of the Contractor to insure that all subcontractors comply with all insurance requirements provided in the Contract.
- 13.1.1.9 It is expressly noted that the insurance requirements contained herein are minimum requirements, subject to modification by the County in response to high hazard operations.

ARTICLE XIV – EQUAL EMPLOYMENT OPPORTUNITY

14.1 Contractor's Employment Opportunity

- 14.1.1 The Contractor and all Subcontractors shall not discriminate against any employee or applicant for employment because of race, religion, color, sex, national origin or age.

The Contractor shall take affirmative measures to insure that applicants are employed, and that employees are treated during employment without regard to their race, religion, color, sex, national origin or age. Such action shall include, but not be limited to, the following: employment, upgrading, demotion or transfer, recruitment or recruitment advertisement, layoff or termination, rates of pay or other forms of compensation, and selection for training, including apprenticeship. The Contractor agrees to post in conspicuous places, available to employees and applicants for employment, notices setting forth the policies of non-discrimination.

- 14.1.2 The Contractor and all Subcontractors shall, in all solicitations or advertisements for employees placed by them or on their behalf, state that all qualified applicants shall receive consideration for employment without regard to race, religion, color, sex, national origin or age.

ARTICLE XV – APPRENTICESHIP LAW REQUIREMENTS

15.1 Apprenticeship Law (Chapter 446, Florida Statutes)

- 15.1.1 In accordance with applicable Florida law, the Contractor shall make a diligent effort to hire for performance of the Contract a number of apprentices in each occupation which bears to the average number of journeyman in that occupation to be employed in the performance of the Contract, the ratio of at least one (1) apprentice or trainee to every five (5) journeymen.
- 15.1.2 The Contractor shall, when feasible and except when the number of apprentices or trainees to be hired is fewer than four (4), assure that twenty-five (25) percent of such apprentices or trainees are in their first year of training. Feasibility here involves a consideration of the availability of training opportunities for first year apprentices or trainees, the hazardous nature of the Work for beginning workers, and excessive unemployment of apprentices or trainees in their second or subsequent years of training.
- 15.1.3 The Contractor, during the performance of the Contract, shall make diligent efforts to employ the number of apprentices or trainees necessary to meet requirements of Subparagraphs a. and b. However, on-the-job training programs shall only be established in non-apprenticable trades or occupations to meet the requirements of this section.
- 15.1.4 The Contractor agrees to return records of employment, by trade, of the number of apprentices or trainees by first year of training, and the number of journeymen and the wages paid, and hours of work, of such persons on a form as prescribed by the Bureau of Apprenticeship of the Division of Labor at three (3) month intervals. Submission

of duplicate copies of forms submitted to the United States Department of Labor shall be sufficient compliance with the provisions of the section.

- 15.1.5 The Contractor agrees to supply the Bureau of Apprenticeship of the Division of Labor, at three (3) months intervals, a statement describing steps taken toward making diligent effort and containing a breakdown by craft or hours worked and wages paid for first year apprentices or trainees, other apprentices or trainees and journeymen.
- 15.1.6 The Contractor agrees to insert in any Subcontract under the Contract the requirements contained in this section. "The term Contractor" as used in such clauses and any Subcontract shall mean the Subcontractor.
- 15.1.7 Anything herein to the Contrary notwithstanding, Contractor agrees to comply with all of the provisions of Florida Statutes 446 and all regulations prescribed by the Bureau of Apprenticeship of the Division of Labor.

ARTICLE XVI – PUBLIC RECORDS

16.1 Public Records (Chapter 119, Florida Statutes)

- 16.1.1 The cost of reproduction, access to, disclosure, non-disclosure, or exemption of records, data, documents, and/or materials, associated with this Agreement shall be subject to the applicable provisions of the Florida Public Records Law (Chapter 119, Florida Statutes), and other applicable State and Federal provisions. Access to such public records, may not be blocked, thwarted, and/or hindered by placing the public records in the possession of a third party, or an unaffiliated party.
- 16.1.2 In accordance with Florida law, to the extent that Contractor's performance under this Contract constitutes an act on behalf of the County, Contractor shall comply with all requirements of Florida's public records law. Specifically, if Contractor is expressly authorized, and acts on behalf of the County under this Agreement, Contractor shall:
 - (1) Keep and maintain public records that ordinarily and necessarily would be required by the County in order to perform the Services;
 - (2) Upon request from the County's custodian of public records, provide the County with a copy of the requested records or allow the records to be inspected or copied within a reasonable time at a cost that does not exceed the cost as provided in Chapter 119, Florida Statutes, or as otherwise provided by law;
 - (3) Ensure that public records related to this Agreement that are exempt or confidential and exempt from public records disclosure requirements are not disclosed except as authorized by applicable law for the duration of this Agreement and following completion of this Agreement if the Contractor does not transfer the records to the County; and
 - (4) Upon completion of this Agreement, transfer, at no cost, to the County all public records in possession of the Contractor or keep and maintain public records required by the County to perform the Services.
- 16.1.3 If the Contractor transfers all public records to the County upon completion of this Agreement, the Contractor shall destroy any duplicate public records that are exempt or confidential and exempt from public records disclosure requirements. If the Contractor keeps and maintains public records upon completion of this Agreement, the Contractor shall meet all applicable requirements for retaining public records. All records stored electronically must be provided to the County, upon request from the County's custodian of public records, in a format that is compatible with the County's information technology systems.
- 16.1.4 Failure by the Contractor to comply with the requirements of this section shall be grounds for immediate, unilateral termination of this Agreement by the County.

IF THE CONTRACTOR HAS QUESTIONS REGARDING THE APPLICATION OF CHAPTER 119, FLORIDA STATUTES, TO ITS DUTY TO PROVIDE PUBLIC RECORDS RELATING TO THIS AGREEMENT, CONTACT THE CUSTODIAN OF PUBLIC RECORDS AT: 500 San Sebastian View, St. Augustine, FL 32084, (904) 209-0805, publicrecords@sjcfl.us

ARTICLE XVII – MISCELLANEOUS

17.1 Governing Law and Venue

17.1.1 The Contract shall be governed by the laws of the State of Florida. Venue for any administrative and/or legal action arising under the Contract shall be St. Johns County, Florida.

17.2 Successors and Assigns

17.2.1 The County and Contractor bind themselves, their successors, assigns and legal representatives to the other party hereto and to successors, assigns and legal representatives of such other party in respect to covenants, agreements and obligations contained in the Contract. In light of the scope and rationale for the Contract, the Contractor shall not assign the Contract without prior express written consent of the County. However, the County shall not unreasonably deny such written consent, when the interests of the County are not negatively affected. Should the Contractor assign this Contract without securing the prior express written consent of the County, then the County may pursue any legal option available to the County, including, but not limited to, termination of the Contract.

17.3 Surety Bonds

17.3.1 For each project, the Contractor shall furnish a separate Public Construction Bond to the County. Each Bond shall set forth a penal sum in an amount not less than the Project Price. Each Bond furnished by the Contractor shall incorporate by reference the terms of the Contract as fully as though they were set forth verbatim in such Bonds. Each Public Construction Bond shall provide that in the event the Project Price is adjusted by Change Order executed by the Contractor, the Contractor shall obtain a an Amended Public Construction Bond, or a New Public Construction Bond which reflects the adjusted Project Price. Such Amended or New Public Construction Bond shall be provided to the County within ten (10) days of the Change Order being approved to adjust the Project Price. The Public Construction Bond furnished by the Contractor shall be in form suitable to the County and shall be executed by a Surety, or Sureties, reasonably suitable to the County.

17.4. Safety of Persons and Property

17.4.1 When existing utility lines shown on the Drawings are to be removed or relocated, the Contractor shall notify the Engineer in ample time for taking measures for prevention of the interruption of any required services prior to the beginning of operations. In the event that the Contractor damages any existing utility lines not shown on the Drawings, the location of which is not known to the Contractor, report thereof shall be made immediately to the Engineer.

17.4.2 Locations of existing utility lines shown on the Drawings are based upon the best information available to the Engineer, but shall not be considered exact either as to location or number of such lines.

17.4.3 Contractor shall protect utility lines constructed pursuant to terms of the Contract and those discovered or shown on Drawings to be existing. Damage occurring to utility lines due to Contractor's operations shall be repaired at no cost to the County.

17.5 Amendments

It is expressly understood that any change, amendment, modification, revision, or extension of the Contract (other than termination, as noted elsewhere in the Contract) shall be in writing, and shall be executed by duly authorized representatives of both the County and the Contractor.

17.6 Compliance with Local, State, and Federal Rules, Regulations, and Laws

In performance of the Contract, both the County and the Contractor shall abide by, and comply with, all applicable laws, rules, regulations, orders, and policies, of the Local, State, and Federal governments.

17.7 Effect of Failure to Insist on Strict Compliance with Conditions

The failure of either party hereto to insist upon strict performance of any term, condition, provision, and/or requirement of the Contract, shall not be construed as a waiver of such term, condition, provision, and/or requirement on any subsequent occasion.

17.8 Severability

If any word, phrase, sentence, part, subsection, section, or other portion of the Contract, or any application thereof, to any person, or circumstance is declared void, unconstitutional, or invalid for any reason, then such word, phrase, sentence, part, subsection, other portion, or the proscribed application thereof, shall be severable, and the remaining portions of the Contract, and all applications thereof, not having been declared void, unconstitutional, or invalid shall remain in full force, and effect.

17.9 Execution in Counterparts

The Contract may be executed in counterparts, each of which shall be deemed to be an original, but all of which, taken together, shall constitute one and the same agreement.

17.10 Authority to Execute

Each party covenants to the other party hereto that it has the lawful authority to enter into the Contract and has authorized the execution of the Contract by the party's authorized representative.

17.11 Notice Regarding Public Entity Crimes

Section 287.133(3)(a), Florida Statutes requires the County to notify the Contractor of the provisions of Section 287.133(2)(a), Florida Statutes.

Section 287.133(2)(a), Florida Statutes prohibits a person or affiliate who has been placed on the convicted vendor list maintained by the Florida Department of Management Services, following a conviction from a public entity crime from:

- (a) Contracting to provide goods or services to a public entity;
- (b) Submitting a bid on a contract for construction or repair of a public building or public work;
- (c) Submitting bids on leases of real property to a public entity;
- (d) Being awarded or perform work as a contractor, supplier, subcontractor, or consultant under a contract with any public entity in excess of \$10,000.00.

The prohibitions listed above apply for a period of thirty-six (36) months from the date a person or affiliate is placed on the convicted vendor list.

17.12. Termination Under Section 287.135, Florida Statutes

Notwithstanding any other provision in the Contract to the contrary, the County will have the option, in the exercise of its sole discretion, to immediately terminate the Contract if the Contractor is found to have submitted a false certification under Section 287.135(5), Florida Statutes, or has been placed on the Scrutinized Companies with Activities in the Iran Petroleum Energy Sector List, as described in Section 287.135, Florida Statutes.

17.13. Royalties and Payments

The Contractor hereby certifies that to the best of the Contractor's information, neither the Contractor, nor any process employed by the Contractor, infringes upon any trademark, patent, or other intellectual property rights of another party. Moreover, the Contractor agrees to pay (where required and/or applicable) any, and all, applicable royalties, and or license fees that are associated with any aspect of this Project.

17.14. Permits and Licenses.

To the extent required, the Contractor (at its sole expense) shall secure, obtain, acquire, and maintain permits, approvals, certificates, and/or licenses, in order to perform the Work referenced in the Contract, the Contractor shall be responsible or securing, obtaining, acquiring and maintaining at the Contractor's sole expense, and cost, any, and all, permits, licenses, certificates, and/or approvals required by Federal, State, and/or Local law, rule, regulation, or ordinance.

17.15. Completion of All Required Forms

Throughout the duration of the Contract, the Contractor has an on-going duty to timely complete all forms required by Federal, State, or local law, rule, regulation, or ordinance, and where required, timely submit the required form to the applicable entity/person.

17.16. No Third Party Beneficiaries

Both the County and the Contractor explicitly agree, and the Contract explicitly states that no third party beneficiary status or interest is conferred to, or inferred to, any other person or entity.

17.17. E-Verify

The Contractor agrees that it will enroll and participate in the federal E-verify Program for Employment Verification. The Contractor further agrees to comply with, and abide by, any, and all, applicable rules and provisions associated with the federal E-verify Program for Employment Verification.

17.18. Survival.

It is explicitly noted that the following provisions identified by numbered caption and contained herein shall survive any suspension, termination, cancellation, revocation, expiration and/or non-renewal of the Contract, and therefore shall be both applicable and enforceable beyond any suspension, termination, cancellation, revocation, expiration and/or non-renewal: (1) Article 1.5 (Intent and Interpretation); (2) Article 1.6 Ownership of Contract Documents; (3) Article 7.4 (Warranty); (4) Article 7.12 (Indemnity); (5) Article 11 (Uncovering and Correcting Work); and (6) Article 12.2.2 (Termination for Cause).

IN WITNESS WHEREOF, the Board of County Commissioners of St. Johns County, Florida has made and executed this Contract on behalf of the COUNTY and CONTRACTOR has hereunto set his/her hand the day and year above written.

COUNTY

CONTRACTOR

St. Johns County, FL (Seal)

Wharton-Smith, Inc (Seal)

By: *Jaime Locklear*
(Signature County Representative)

By: *Ronald F. Davoli*
(Signature Contractor Representative)

Jaime T. Locklear, MPA, CPPB, FCCM
(Printed Name of Signing Representative)

Ronald F. Davoli
(Printed Name of Contractor Representative)

Assistant Purchasing Manager
(Title of Signing Representative)

President / CEO
(Title of Signing Representative)

1/26/18
(Date of Execution)

01/25/2018
(Date of Execution)

ATTEST:
St. Johns County, FL
Clerk of Courts

By: *Mitchell McFee*
Deputy Clerk

1-26-18
Date of Execution



LEGALLY SUFFICIENT:

Signatures
Deputy County Attorney

1/9/18
Date of Execution

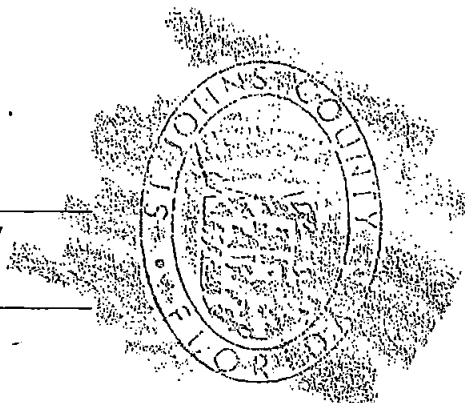

**RFP No: 18-22; Utility Rehabilitation/Construction Services
MASTER CONTRACT # 18-MCC-WHA-08956**

**EXHIBIT "A"
UNIT PRICE LIST**

Part A – Manhole/Wetwell Rehabilitation – Polyurethane, Modified Polymer or Epoxy Barrier

ITEM NO.	DESCRIPTION	ESTIMATED QUANTITY	UNIT	UNIT PRICE
A.	Clean New Sanitary Sewer Manhole/Wetwell	100	SF	3.15
B.	Clean Existing Sanitary Sewer Manhole/Wetwell	5000	SF	7.73
C.	Chemical Grout Injection (Small)	50	TUBE	196.88
D.	Chemical Grout Injection (Large)	50	GAL	196.88
E.	Repair Wall w/ High Strength Mortar (Ave 2" Depth)	500	SF	29.93
F.	Coat New Sanitary Sewer Manhole	100	SF	37.80
G.	Coat Existing Sanitary Sewer Manhole	5000	SF	50.40
H.	Coat Existing Wetwell	500	SF	50.40
I.	Interior Manhole Coating/Lining Repair	100	SF	100.80
J.	Manhole Test	10	EA	235.80
K.	Concrete Adjustment Rings (0"-12")	10	EA	3300.00
L.	Concrete Adjustment Rings (Each Additional 6" Over Initial 12")	1	VF	3300.00
M.	Bench Replacement	10	EA	1800.00
N.	Replace Frame & Cover (24"-30")	10	EA	3300.00
O.	Replace Frame & Cover (32"-36")	10	EA	5100.00
P.	Inside Drop System 4" - 8"	1	EA	2250.00
Q.	Inside Drop System 10" - 12"	1	EA	2625.00
R.	Maintenance of Traffic			
a.	Traffic Control – MOT Index 601 or 602 (per day)	1	DAY	1770.00
b.	Traffic Control – MOT Index 603 or higher (per day)	1	DAY	1770.00
c.	Traffic Control – MOT Index 601 or 602 (per week)	1	WK	2220.00
d.	Traffic Control – MOT Index 603 or higher (per week)	1	WK	2220.00
e.	Variable Message Board (per week)	1	WK	675.00
S.	Regular Mobilization (~ 4-6 weeks)	1	EA	12,000.00
T.	Emergency Mobilization (< 1 week)	1	EA	30,150.00
U.	Construction Performance & Payment Bond Not to Exceed 2%		%	1.6%

Part B – Manhole/Wetwell Rehabilitation – Cementious Barrier

ITEM NO.	DESCRIPTION	ESTIMATED QUANTITY	UNIT	UNIT PRICE
A.	Clean New Sanitary Sewer Manhole/Wetwell	100	SF	3.15
B.	Clean Existing Sanitary Sewer Manhole/Wetwell	5000	SF	7.73
C.	Chemical Grout Injection (Small)	50	TUBE	196.88
D.	Chemical Grout Injection (Large)	50	GAL	196.88
E.	Repair Wall w/ High Strength Mortar (Ave 2" Depth)	500	SF	29.93
F.	Coat New Sanitary Sewer Manhole	100	SF	33.00
G.	Coat Existing Sanitary Sewer Manhole	5000	SF	43.50
H.	Coat Existing Wetwell	500	SF	43.50
I.	Interior Manhole Coating/Lining Repair	100	SF	100.80
J.	Manhole Test	10	EA	235.80
K.	Concrete Adjustment Rings (0"-12")	10	EA	3300.00
L.	Concrete Adjustment Rings (Each Additional 6" Over Initial 12")	1	VF	3300.00
M.	Bench Replacement	10	EA	1800.00
N.	Replace Frame & Cover (24"-30")	10	EA	3675.00
O.	Replace Frame & Cover (32"-36")	10	EA	5175.00
P.	Inside Drop System 4" - 8"	1	EA	2250.00
Q.	Inside Drop System 10" - 12"	1	EA	2625.00
R.	Maintenance of Traffic			
a.	Traffic Control – MOT Index 601 or 602 (per day)	1	DAY	1770.00
b.	Traffic Control – MOT Index 603 or higher (per day)	1	DAY	1770.00
c.	Traffic Control – MOT Index 601 or 602 (per week)	1	WK	2220.00
d.	Traffic Control – MOT Index 603 or higher (per week)	1	WK	2220.00
e.	Variable Message Board (per week)	1	WK	675.00
S.	Regular Mobilization (~ 4-6 weeks)	1	EA	12,000.00
T.	Emergency Mobilization (< 1 week)	1	EA	30,150.00
U.	Construction Performance & Payment Bond Not to Exceed 2%		%	1.6%

Part C – Sanitary Sewer Rehabilitation – Cured-in-place Pipe (CIPP)

ITEM NO.	DESCRIPTION	ESTIMATED QUANTITY	UNIT	UNIT PRICE
A. Sanitary Sewer Line Cleaning and Inspection				
a.	Light Cleaning (<1/4 diameter)			
1	4" Diameter	200	LF	N/A
2	6" Diameter	500	LF	N/A
3	8" Diameter	6,000	LF	3.00
4	10" Diameter	500	LF	6.00
5	12" Diameter	200	LF	12.00
6	15" Diameter	100	LF	24.00
7	18" Diameter	100	LF	24.00
b.	Tuberculation Cleaning			
1	4" Diameter	100	LF	N/A
2	6" Diameter	200	LF	N/A
3	8" Diameter	1,000	LF	30.00
4	10" Diameter	200	LF	30.00
5	12" Diameter	100	LF	37.50
6	15" Diameter	50	LF	75.00
7	18" Diameter	50		75.00
c.	Root Removal			
1	4" Diameter	100	LF	N/A
2	6" Diameter	200	LF	N/A
3	8" Diameter	1,000	LF	30.00
4	10" Diameter	200	LF	30.00
5	12" Diameter	50	LF	75.00
6	15" Diameter	50	LF	75.00
7	18" Diameter			n/a
d.	CCTV Inspection - Sewer Lateral			
1	Lateral Inspection 0' to 40'	20	EA	450.00
2	Additional Lateral Inspection >40'	1	LF	6.00
e.	CCTV Pipe Inspection			
1	6" Diameter	500	LF	4.80
2	8" Diameter	6,000	LF	3.00
3	10" Diameter	500	LF	4.80
4	12" Diameter	200	LF	12.00
5	15" Diameter	100	LF	24.00
6	18" Diameter	100	LF	24.00
B. Sanitary Sewer Rehabilitation				
1. CIPP lining				
a.	6" Diameter			
1	3.0 mm UV CIPP	500	LF	128.25
b.	8" Diameter			
1	3.0 mm UV CIPP	6,000	LF	128.25
2	4.0 mm UV CIPP	1	LF	135.75
3	5.0 mm UV CIPP	1	LF	143.25
c.	10" Diameter			
1	3.0 mm UV CIPP	500	LF	135.75
2	4.0 mm UV CIPP	1	LF	143.25
3	5.0 mm UV CIPP	1	LF	150.75
d.	12" Diameter			
1	3.0 mm UV CIPP	500	LF	174.75
2	4.0 mm UV CIPP	1	LF	180.75

3	5.0 mm UV CIPP	1	LF	188.25
e.	15" Diameter			
1	3.0 mm UV CIPP	200	LF	180.75
2	4.0 mm UV CIPP	1	LF	188.25
3	5.0 mm UV CIPP	1	LF	195.75
f.	18" Diameter			
1	3.0 mm UV CIPP	100	LF	218.25
2	4.0 mm UV CIPP	1	LF	225.75
3	5.0 mm UV CIPP	1	LF	233.25
2. Sectional CIPP lining				
a.	6" Diameter			
1	3' in length	1	EA	7981.50
2	4' in length	1	EA	8421.00
3	6' in length	1	EA	8595.00
4	8' in length	1	EA	8887.50
b.	8" Diameter			
1	3' in length	1	EA	8167.50
2	4' in length	1	EA	8326.50
3	6' in length	1	EA	8862.00
4	8' in length	1	EA	9235.50
c.	10" Diameter			
1	3' in length	1	EA	8313.00
2	4' in length	1	EA	8461.50
3	6' in length	1	EA	9075.00
4	8' in length	1	EA	9609.00
d.	12" Diameter			
1	3' in length	1	EA	8446.50
2	4' in length	1	EA	8862.00
3	6' in length	1	EA	9342.00
4	8' in length	1	EA	10,167.00
e.	15" diameter			
1	3' in length	1	EA	8556.00
2	4' in length	1	EA	9202.50
3	6' in length	1	EA	9525.00
4	8' in length	1	EA	10,537.50
f.	18" diameter			
1	3' in length	1	EA	8862.00
2	4' in length	1	EA	9583.50
3	6' in length	1	EA	10,354.50
4	8' in length	1	EA	11,205.00
3. Lateral CIPP Lining				
a.	Top hat / full wrap - up to 36 inches			
1	4" lateral connection	10	EA	4650.00
2	6" lateral connection	50	EA	4800.00
3	8" lateral connection	1	EA	5250.00
b.	Lateral lining 0 to 40'	10	EA	3000.00
c.	Additional lateral lining >40'	1	LF	75.00
d.	Lateral cutout & polish	200	EA	750.00
e.	Lateral grout	50	EA	525.00
4. Cleanout Installation				
a.	4" cleanout	1	EA	2265.00
b.	6" cleanout	1	EA	2310.00

c.	8" cleanout	1	EA	2370.00
C. Maintenance of Traffic				
a.	Traffic Control – MOT Index 601 or 602 (per day)	1	DAY	1770.00
b.	Traffic Control – MOT Index 603 or higher (per day)	1	DAY	1770.00
c.	Traffic Control – MOT Index 601 or 602 (per week)	1	WK	2220.00
d.	Traffic Control – MOT Index 603 or higher (per week)	1	WK	2220.00
e.	Variable Message Board (per week)	1	WK	675.00
D. Mobilization				
a.	Regular Mobilization (~ 4-6 weeks)	1	EA	13,050.00
b.	Emergency Mobilization (< 1 week)	1	EA	41,100.00
E. Bond				
a.	Contract Performance and Payment Bond Cost Not to Exceed 2%			1.6%

Part D – Time & Materials for Water, Wastewater, & Reuse Projects

ITEM NO.	DESCRIPTION	HOURLY BASE RATE	HOURLY BILLING RATE*	OVERTIME BILLING RATE**	HOLIDAY BILLING RATE***
A. Labor					
a.	Project Manager	78.00	144.30	216.45	288.60
b.	Superintendent	76.20	140.97	211.46	281.94
c.	Foreman	36.00	66.60	99.90	133.20
d.	Equipment Operator	42.00	77.70	116.55	155.40
e.	Truck Driver	n/a	n/a	n/a	n/a
f.	Pipe Layer	30.00	55.50	83.25	111.00
g.	Skilled Laborer	25.00	46.25	69.38	92.50
h.	Unskilled Laborer	20.00	37.00	55.50	74.00
B. Equipment					
a.	Backhoe	24.00	48.00	72.00	96.00
b.	Excavator	84.00	168.00	252.00	336.00
c.	Small Loader/Skid Steer Loader	34.00	68.00	102.00	136.00
d.	Grader	n/a	n/a	n/a	n/a
e.	Dozer	61.00	122.00	183.00	244.00
f.	Dump Truck	100.00	100.00	150.00	200.00
g.	Small Equipment/Tools	15.00	30.00	45.00	60.00
C. Materials				COST + MAX. 15% MARKUP	
D. Subcontractors				COST + MAX. 5% MARKUP	
E. Rentals				COST + MAX. 5% MARKUP	
F. Mobilization					
a.	Regular Mobilization (~ 4-6 weeks)	1	EA		10,000.00
b.	Emergency Mobilization (< 1 week)	1	EA		20,000.00
Sub-total					\$
G. Bond					
a.	Contract Performance and Payment Bond Cost Not to Exceed 2%			1.6%	

RFP No: 18-22; Utility Rehabilitation/Construction Services
MASTER CONTRACT # 18-MCC-WHA-08956
EXHIBIT "C"

FEMA PUBLIC ASSISTANCE PROGRAM REQUIRED CONTRACT CLAUSES

1. Equal Employment Opportunity.

If this contract meets the definition of a "federally assisted construction contract" as provided in 41 C.F.R. § 60-1.3, the following shall apply to the contractor's performance under this contract:

- a. The contractor will not discriminate against any employee or applicant for employment because of race, color, religion, sex, or national origin. The contractor will take affirmative action to ensure that applicants are employed, and that employees are treated during employment without regard to their race, color, religion, sex, or national origin. Such action shall include, but not be limited to the following: Employment, upgrading, demotion, or transfer; recruitment or recruitment advertising; layoff or termination; rates of pay or other forms of compensation; and selection for training, including apprenticeship. The contractor agrees to post in conspicuous places, available to employees and applicants for employment, notices to be provided setting forth the provisions of this nondiscrimination clause.
- b. The contractor will, in all solicitations or advertisements for employees placed by or on behalf of the contractor, state that all qualified applicants will receive considerations for employment without regard to race, color, religion, sex, or national origin.
- c. The contractor will send to each labor union or representative of workers with which he has a collective bargaining agreement or other contract or understanding, a notice to be provided advising the said labor union or workers' representatives of the contractor's commitments under this section, and shall post copies of the notice in conspicuous places available to employees and applicants for employment.
- d. The contractor will comply with all provisions of Executive Order 11246 of September 24, 1965, and of the rules, regulations, and relevant orders of the Secretary of Labor.
- e. The contractor will furnish all information and reports required by Executive Order 11246 of September 24, 1965, and by rules, regulations, and orders of the Secretary of Labor, or pursuant thereto, and will permit access to his books, records, and accounts by the administering agency and the Secretary of Labor for purposes of investigation to ascertain compliance with such rules, regulations, and orders.
- f. In the event of the contractor's noncompliance with the nondiscrimination clauses of this contract or with any of the said rules, regulations, or orders, this contract may be canceled, terminated, or suspended in whole or in part and the contractor may be declared ineligible for further Government contracts or federally assisted construction contracts in accordance with procedures authorized in Executive Order 11246 of September 24, 1965, and such other sanctions as may be imposed and remedies invoked as provided in Executive Order 11246 of September 24, 1965, or by rule, regulation, or order of the Secretary of Labor, or as otherwise provided by law.
- g. The contractor will include the portion of the sentence immediately preceding paragraph (a) and the provisions of paragraphs (a) through (g) in every subcontract or purchase order unless exempted by rules, regulations, or orders of the Secretary of Labor issued pursuant to section 204 of Executive Order 11246 of September 24, 1965, so that such provisions will be binding upon each subcontractor or vendor. The contractor will take such action with respect to any subcontract or purchase order as the administering agency may direct as a means of enforcing such provisions, including sanctions for noncompliance: Provided, however, That in the event a contractor becomes involved in, or is threatened with, litigation with a subcontractor or vendor as a result of such direction by the administering agency the contractor may request the United States to enter into such litigation to protect the interests of the United States."

For the purposes of this section, "federally assisted construction contract" means any agreement or modification thereof between any applicant and a person for construction work which is paid for in whole or in part with funds obtained from the Government or borrowed on the credit of the Government pursuant to any Federal program involving a grant, contract, loan, insurance, or guarantee, or undertaken pursuant to any Federal program involving such grant, contract, loan, insurance, or guarantee, or any application or modification thereof approved by the

Government for a grant, contract, loan, insurance, or guarantee under which the applicant itself participates in the construction work.

For the purposes of this section, "construction work" means the construction, rehabilitation, alteration, conversion, extension, demolition or repair of buildings, highways, or other changes or improvements to real property, including facilities providing utility services. The term also includes the supervision, inspection, and other onsite functions incidental to the actual construction.

2. Contract Work Hours and Safety Standards Act.

- a. This section applies to all contracts in excess of \$100,000 that involve the employment of mechanics or laborers as provided in 40 U.S.C. § 3701.
- b. As provided in 40 U.S.C. § 3702, the contractor shall compute the wages of every mechanic and laborer on the basis of a standard work week of 40 hours. Work in excess of the standard work week is permissible provided that the worker is compensated at a rate of not less than one and a half times the basic rate of pay for all hours worked in excess of 40 hours in the work week.
- c. The requirements of 40 U.S.C. § 3704 shall apply to construction work and provide that no laborer or mechanic must be required to work in surroundings or under working conditions which are unsanitary, hazardous or dangerous. These requirements do not apply to the purchases of supplies or materials or articles ordinarily available on the open market, or contracts for transportation or transmission of intelligence.
- d. No contractor or subcontractor contracting for any part of the contract work which may require or involve the employment of laborers or mechanics shall require or permit any such laborer or mechanic in any workweek in which he or she is employed on such work to work in excess of forty hours in such workweek unless such laborer or mechanic receives compensation at a rate not less than one and one-half times the basic rate of pay for all hours worked in excess of forty hours in such workweek.
- e. In the event of any violation of the clause set forth in paragraph (d) of this section the contractor and any subcontractor responsible therefor shall be liable for the unpaid wages. In addition, such contractor and subcontractor shall be liable to the United States (in the case of work done under contract for the District of Columbia or a territory, to such District or to such territory), for liquidated damages. Such liquidated damages shall be computed with respect to each individual laborer or mechanic, including watchmen and guards, employed in violation of the clause set forth in paragraph (d) of this section, in the sum of \$10 for each calendar day on which such individual was required or permitted to work in excess of the standard workweek of forty hours without payment of the overtime wages required by the clause set forth in paragraph (d) of this section.
- f. The County shall upon its own action or upon written request of an authorized representative of the Department of Labor withhold or cause to be withheld, from any moneys payable on account of work performed by the contractor or subcontractor under any such contract or any other Federal contract with the same prime contractor, or any other federally-assisted contract subject to the Contract Work Hours and Safety Standards Act, which is held by the same prime contractor, such sums as may be determined to be necessary to satisfy any liabilities of such contractor or subcontractor for unpaid wages and liquidated damages as provided in the clause set forth in paragraph (e) of this section.
- g. The contractor or subcontractor shall insert in any subcontracts the clauses set forth in paragraph (c) through (f) of this section and also a clause requiring the subcontractors to include these clauses in any lower tier subcontracts. The prime contractor shall be responsible for compliance by any subcontractor or lower tier subcontractor with the clauses set forth in paragraphs (c) through (f) of this section.

3. Compliance with Clean Air Act.

- a. The contractor agrees to comply with all applicable standards, orders or regulations issued pursuant to the Clean Air Act, as amended, 42 U.S.C. § 7401 et seq.
- b. The contractor agrees to report each violation to the County and understands and agrees that the County will, in turn, report each violation as required to assure notification to the state of Florida, Federal Emergency Management Agency, and the appropriate Environmental Protection Agency Regional Office.

- c. The contractor agrees to include these requirements in each subcontract exceeding \$100,000 financed in whole or in part with Federal assistance provided by FEMA.

4. Compliance with Federal Water Pollution Control Act.

- a. The contractor agrees to comply with all applicable standards, orders or regulations issued pursuant to the Federal Water Pollution Control Act, as amended, 33 U.S.C. 1251 et seq.
- b. The contractor agrees to report each violation to the County and understands and agrees that the County will, in turn, report each violation as required to assure notification to the state of Florida, Federal Emergency Management Agency, and the appropriate Environmental Protection Agency Regional Office.
- c. The contractor agrees to include these requirements in each subcontract exceeding \$100,000 financed in whole or in part with Federal assistance provided by FEMA.

5. Debarment and Suspension.

- a. This contract is a covered transaction for purposes of 2 C.F.R. pt. 180 and 2 C.F.R. pt. 3000. As such the contractor is required to verify that none of the contractor, its principals (defined at 2 C.F.R. § 180.995), or its affiliates (defined at 2 C.F.R. § 180.905) are excluded (defined at 2 C.F.R. § 180.940) or disqualified (defined at 2 C.F.R. § 180.935).
- b. The contractor must comply with 2 C.F.R. pt. 180, subpart C and 2 C.F.R. pt. 3000, subpart C and must include a requirement to comply with these regulations in any lower tier covered transaction it enters into.
- c. This certification is a material representation of fact relied upon by the County. If it is later determined that the contractor did not comply with 2 C.F.R. pt. 180, subpart C and 2 C.F.R. pt. 3000, subpart C, in addition to remedies available to the state of Florida and the County, the Federal Government may pursue available remedies, including but not limited to suspension and/or debarment.
- d. The bidder or proposer agrees to comply with the requirements of 2 C.F.R. pt. 180, subpart C and 2 C.F.R. pt. 3000, subpart C while this offer is valid and throughout the period of any contract that may arise from this offer. The bidder or proposer further agrees to include a provision requiring such compliance in its lower tier covered transactions.

6. Byrd Anti-Lobbying Amendment

Contractors who apply or bid for an award of \$100,000 or more shall file the required certification. Each tier certifies to the tier above that it will not and has not used Federal appropriated funds to pay any person or organization for influencing or attempting to influence an officer or employee of any agency, a member of Congress, officer or employee of Congress, or an employee of a member of Congress in connection with obtaining any Federal contract, grant, or any other award covered by 31 U.S.C. § 1352. Each tier shall also disclose any lobbying with non-Federal funds that takes place in connection with obtaining any Federal award. Such disclosures are forwarded from tier to tier up to the recipient.

APPENDIX A, 44 C.F.R. PART 18: CERTIFICATION REGARDING LOBBYING

Certification for Contracts, Grants, Loans, and Cooperative Agreements (To be submitted with each bid or offer exceeding \$100,000)

The undersigned [Contractor] certifies, to the best of his or her knowledge, that:

- 1. No Federal appropriated funds have been paid or will be paid, by or on behalf of the undersigned, to any person for influencing or attempting to influence an officer or employee of an agency, a Member of Congress, an officer or employee of Congress, or an employee of a Member of Congress in connection with the awarding of any Federal contract, the making of any Federal grant, the making of any Federal loan, the entering into of any cooperative agreement, and the extension, continuation, renewal, amendment, or modification of any Federal contract, grant, loan, or cooperative agreement.
- 2. If any funds other than Federal appropriated funds have been paid or will be paid to any person for influencing or attempting to influence an officer or employee of any agency, a Member of Congress, an officer or employee of Congress, or an employee of a Member of Congress in connection with this

Federal contract, grant, loan, or cooperative agreement, the undersigned shall complete and submit Standard Form- LLL, "Disclosure Form to Report Lobbying," in accordance with its instructions.

3. The undersigned shall require that the language of this certification be included in the award documents for all subawards at all tiers (including subcontracts, subgrants, and contracts under grants, loans, and cooperative agreements) and that all subrecipients shall certify and disclose accordingly.

This certification is a material representation of fact upon which reliance was placed when this transaction was made or entered into. Submission of this certification is a prerequisite for making or entering into this transaction imposed by 31, U.S.C. § 1352 (as amended by the Lobbying Disclosure Act of 1995). Any person who fails to file the required certification shall be subject to a civil penalty of not less than \$10,000 and not more than \$100,000 for each such failure.

The Contractor, certifies or affirms the truthfulness and accuracy of each statement of its certification and disclosure, if any. In addition, the Contractor understands and agrees that the provisions of 31 U.S.C. § 3801 et seq., apply to this certification and disclosure, if any.

Signature of Contractor's Authorized Official

Name and Title of Contractor's Authorized Official

Date

7. Procurement of Recovered Materials.

- a. In the performance of this contract, the Contractor shall make maximum use of products containing recovered materials that are EPA- designated items unless the product cannot be acquired—
 - i. Competitively within a timeframe providing for compliance with the contract performance schedule;
 - ii. Meeting contract performance requirements; or
 - iii. At a reasonable price.

8. DHS Seal, Logo, and Flags.

The contractor shall not use the DHS seal(s), logos, crests, or reproductions of flags or likenesses of DHS agency officials without specific FEMA pre-approval.

9. Compliance with Federal Law, Regulations, and Executive Orders.

This is an acknowledgement that FEMA financial assistance will be used to fund the contract only. The contractor will comply with all applicable federal law, regulations, executive orders, FEMA policies, procedures, and directives.

10. No Obligation by Federal Government.

The Federal Government is not a party to this contract and is not subject to any obligations or liabilities to the non-Federal entity, contractor, or any other party pertaining to any matter resulting from the contract.

11. Fraud and False or Fraudulent or Related Acts.

The contractor acknowledges that 31 U.S.C. Chap. 38 (Administrative Remedies for False Claims and Statements) applies to the contractor's actions pertaining to this contract.

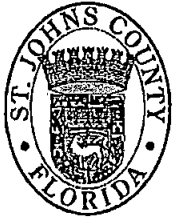

St. Johns County Board of County Commissioners

Purchasing Division

January 29, 2018

Wharton-Smith, Inc.
750 Monroe Rd
Sanford, FL 32771

**RE: RFP No: 18-22 – Utility Rehabilitation/Construction Services
Master Contract No: 18-MCC-WHA-08956**

Dear Mr. Davoli,

Attached, please find a fully executed original copy of the Contract Agreement for Utility Rehabilitation/Construction Services for your files.

All work under this contract will be authorized by Task Orders. No work shall be performed without an executed Task Order, issued by the SJC Purchasing Department. In the event the County requests a proposal from Wharton-Smith, Inc. regarding a specific project, any and all instructions for the proposal will be included in the request.

If you have any questions regarding this contract, you may contact me at the information below.

Thank you for doing business with St. Johns County.

Sincerely,
St. Johns County, FL
Purchasing Department

A handwritten signature in black ink, appearing to read "Leigh A. Daniels".

Leigh A. Daniels, CPPB
Procurement Supervisor
(904) 209-0154 – Direct
(904) 209-0155 – Fax
ldaniels@sjcfl.us

CC: SJC Minutes & Records (Copy taken when attested)
SJC Purchasing RFP 18-22 – Master Contract File