

RESOLUTION NO. 2023 -501

A RESOLUTION BY THE BOARD OF COUNTY COMMISSIONERS OF ST. JOHNS COUNTY, FLORIDA, AUTHORIZING THE COUNTY ADMINISTRATOR, OR DESIGNEE, TO AWARD BID NO. 23-94; CR 210 WIDENING FROM TRINITY WAY TO BEACHWALK BOULEVARD TO WATSON CIVIL CONSTRUCTION, INC AS THE LOWEST, RESPONSIVE, RESPONSIBLE BIDDER, AND TO EXECUTE AN AGREEMENT FOR COMPLETION OF THE PROJECT.

RECITALS

WHEREAS, the County is progressing with the project to complete the 6-lane widening of CR 210 from Trinity Way to Beachwalk Boulevard, based on designed plans. This will include improvements of the roadway, drainage, signage, pavement markings and maintenance of traffic; and

WHEREAS, through the County’s formal Bid process, Watson Civil Construction, Inc. was the lowest, responsive, responsible, bidder, with a total lump sum bid price of \$12,586,631.05 for the Base Bid and all Alternates as shown on the Bid Form; and

WHEREAS, the County finds that entering into a contract for completion of the work serves a public purpose, and the contract will be in substantial conformance with the attached draft; and

WHEREAS, the project will be funded by the SJC Public Works Department.

NOW, THEREFORE BE IT RESOLVED BY THE BOARD OF COUNTY COMMISSIONERS OF ST. JOHNS COUNTY, FLORIDA, as follows:

Section 1. The above Recitals are incorporated by reference into the body of this Resolution and such Recitals are adopted as finds of fact.

Section 2. The County Administrator, or designee, is hereby authorized to award Bid No. 23-94 to Watson Civil Construction, Inc. as the lowest, responsive, responsible bidder.

Section 3. Upon approval by the Board of County Commissioners, the County Administrator, or designee, is further authorized to execute an agreement in substantially the same form and format as the attached draft for the completion of the project as specifically provided in Bid No: 23-94.

Section 4. To the extent that there are typographical and/or administrative errors that do not change the tone, tenor, or concept of this Resolution, then this Resolution may be revised without subsequent approval by the Board of County Commissioners.

PASSED AND ADOPTED by the Board of County Commissioners of St. Johns County, Florida, this 5th day of December, 2023.

BOARD OF COUNTY COMMISSIONERS OF ST. JOHNS COUNTY, FLORIDA

Rendition Date: DEC 07 2023

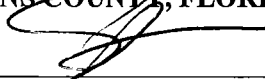
By: 
Sarah Arnold, Chair

ATTEST: Brandon J. Patty,
Clerk of the Circuit Court & Comptroller

By: 
Deputy Clerk





MASTER CONSTRUCTION AGREEMENT
BETWEEN
ST. JOHNS COUNTY AND CONTRACTOR

Master Construction Agreement No: 23-MCA-WAT-19005

Table of Contents

ARTICLE I CONTRACT DOCUMENTS	4
1.1 The Contract Documents	4
1.2 Definitions.....	5
1.3 Ownership of Contract Documents.....	6
ARTICLE II THE WORK.....	7
2.1 Project Description.....	7
2.2 Labor and Materials	7
2.3 Project Sequencing/Arrangement.....	7
2.4 Payment of Costs	7
2.5 Cleaning the Jobsite	7
2.6 Reporting Requirements	8
2.7 Title and Risk of Loss	8
2.8 Access to Work.....	8
2.9 Utilities.....	8
2.10 Existing Utility Lines	8
2.11 Taxes	8
2.12 Publicity and Advertising.....	9
ARTICLE III CONTRACT TIME	9
3.1 Contract Time	9
3.2 Time is of the Essence	9
3.3 Substantial Completion.....	9
3.4 Final Inspection.....	10
3.5 Liquidated Damages	10
3.6 Disclaimer of Consequential Damages	11
ARTICLE IV CONTRACT PRICE AND PAYMENT.....	11
4.1 Contract Price.....	11
4.2 Schedule of Values.....	11
4.3 Measurement and Payment	11
4.4 Progress Payments	12
4.5 Application for Payment	12
4.6 Withheld Payment.....	13
4.7 Final Payment	14
ARTICLE V CONTRACTOR RESPONSIBILITIES	14

5.1	Performance	14
5.2	Authorized Representative	15
5.3	Environmental, Safety and Health	15
ARTICLE VI PROJECT MANAGER		16
6.1	Project Manager Responsibilities.....	16
6.2	Field Orders	17
ARTICLE VII SUBCONTRACTORS		17
7.1	Award of Subcontracts.....	17
ARTICLE VIII CONTRACT DISPUTES/CLAIMS		17
8.1	Contract Claims.....	17
ARTICLE IX CHANGES IN THE WORK		18
9.1	General.....	18
9.2	Changes in the Contract Time.....	19
9.3	Changes in the Contract Price.....	19
9.4	Acceptance of Change Orders.....	20
9.5	Notice to Sureties.....	20
9.6	Differing Site Conditions.....	20
ARTICLE X UNCOVERING WORK, STOPPING WORK,		20
AND ACCEPTING DEFECTIVE OR NONCONFORMING WORK		20
10.1	Uncovering Work.....	20
10.2	Right to Stop Work	21
10.3	County May Accept Defective or Nonconforming Work.....	21
ARTICLE XI CONTRACT SUSPENSION AND TERMINATION		21
11.1	Suspension	21
11.2	Termination.....	21
ARTICLE XII WARRANTY AND INDEMNITY.....		22
12.1	Warranty	22
12.2	Indemnity	23
ARTICLE XIII INSURANCE AND BONDS.....		24
13.1	Contractor's Insurance Requirements	24
13.2	Additional Insured Endorsements and Certificate Holder	24
13.3	Workers Compensation.....	24
13.4	Commercial General Liability	24
13.5	Automobile Liability.....	24
13.6	Additional Coverages.....	24
13.7	Other Requirements	25
13.8	Payment and Performance Bonds	26
ARTICLE XIV MISCELLANEOUS		26
14.1	Independent Contractor.....	26
14.2	Examination of Contractor's Records.....	26

14.3	Backcharges	26
14.4	Applicable Law	26
14.5	Governing Law & Venue	27
14.6	Assignment	27
14.7	Severability	27
14.8	Section Headings.....	27
14.9	Disclaimer of Third-Party Beneficiaries	27
14.10	Waiver; Course of Dealing	27
14.11	No Waiver of Sovereign Immunity.....	27
14.12	Execution in Counterparts.....	27
14.13	Entire Contract	27
14.14	Survival	28
14.15	Employment Eligibility and Mandatory Use of E-Verify	28
14.16	Equal Employment Opportunity	28
14.17	Public Records	29
14.18	Anti-Bribery	30
14.19	Convicted and Discriminatory Vendor Lists, and Scrutinized Companies.....	30
14.20	Written Notice.....	30
	CERTIFICATION OF PAYMENTS TO SUBCONTRACTORS	33
	CONTRACTOR'S FINAL RELEASE AND WAIVER OF LIEN	34

This Master Construction Agreement (“Contract”) is made this _____ day of _____, 2023 (the “Effective Date”) by and between **ST. JOHNS COUNTY** (“County”), a political subdivision of the State of Florida, whose principal offices are located at 500 San Sebastian View, St. Augustine, FL 32084; and **WATSON CIVIL CONSTRUCTION, INC.** (“Contractor”), a company authorized to do business in the State of Florida, with its principal offices located at: 319 West Town Place, Suite 25, St. Augustine, FL 32092, Phone: 904-297-1800, and E-mail: cpeplinski@watsoncivil.com, for **IFB 23-94; CR 210 WIDENING FROM TRINITY WAY TO BEACHWALK BOULEVARD** hereinafter referred to as the “Project”. When referenced together, the County and Contractor shall collectively be referred to as the Parties.

In consideration of the mutual promises and covenants contained herein, the parties hereby agree as follows:

ARTICLE I CONTRACT DOCUMENTS

1.1 The Contract Documents

1.1.1 The Contract Documents are the collective documents which form the Contract, and shall govern completion of the Work. The Contract Documents hereby include the following:

- a) Fully Executed Change Orders and Amendments to this Agreement;
- b) Field Orders signed by County’s Project Manager;
- c) Notice to Proceed;
- d) This Master Construction Agreement and all Exhibits and/or Attachments hereto:
 - i. Exhibit A – CR 210 Widening Construction Plans – September 2023
 - ii. Exhibit B – ECS Florida LLC. Geotechnical Report – December 27, 2019
 - iii. Exhibit C – St. Johns River Water Management Permit 99121-21 – September 16, 2016
 - iv. Exhibit D – Temporary Traffic Control Plan
 - v. Exhibit E – CR 210 Signal Plans for Coordination and Information
- e) Bonds and Insurance furnished by the Contractor
- f) IFB Documents and Bid Forms with all addenda thereto for IFB No. 23-94

1.1.2 Documents not enumerated above are not Contract Documents and do not form part of this Contract. No terms, conditions, limitations or exclusions in Contractor’s submitted Bid or invoices shall be binding upon County or become part of the Contract Documents. In the event of discrepancies, the Contract Documents shall be interpreted in the order of precedence as listed above in Section 1.1.1. Additionally, Specifications shall govern over Drawings, electronic documents shall govern over hard-copy documents, numerical dimensions shall govern over dimensions acquired by scaling, and fully executed documents shall govern over unsigned drafts.

1.1.3 Shop Drawings, Product Data, Samples and similar submittals (hereafter “Submittals”) are not Contract Documents. The County will review and take action upon Contractor's submitted Submittals but only for the limited purpose of checking for conformance with information given and the design concept expressed in the Contract Documents. Review of Submittals is not conducted for the purpose of determining the accuracy and completeness of other details, such as dimensions and quantities, nor for substantiating instructions for installation or performance of equipment or systems, all of which remain the responsibility of Contractor.

1.1.4 All Submittals (whether in hard or soft copy) prepared by or on behalf of Contractor in the course of the Work shall be the exclusive property of the County. Ownership of any proprietary information or intellectual property contained in such Submittals shall remain with Contractor. Contractor grants the County a perpetual, royalty-free, license to use, copy and allow third parties to use such Submittals and all proprietary information contained in them as may be required for the County’s internal business purposes including without limitation tendering, installing, operating, repairing, maintaining, modifying, reconstructing, replacing and/or upgrading the Work. Such license shall be capable of transfer and/or sub-licensing in whole or part without notice to or further consent of Contractor. Contractor shall not be held liable for reuse of Contractor’s Submittals by the County for purposes other than originally intended as stated in the Contract Documents.

1.1.5 Contractor is solely responsible for requesting instructions, interpretations, or clarifications to the Contract Documents and is solely liable for any costs and/or expenses arising from its failure to do so. Contractor shall have a continuing duty to read, carefully study and compare each of the Contract Documents, the Submittals and shall give

immediate written notice to the Project Manager and the County of any inconsistency, ambiguity, error or omission which Contractor may discover with respect to these documents before proceeding with the affected Work. The issuance, or the express or implied approval by the County or the Project Manager of the Contract Documents or Submittals shall not relieve any such approval by evidence of Contractor's compliance with the Contract. The County has requested the Project Manager to provide to Contractor documents for the Project, including the Drawings and Specifications for the Project, which are accurate, adequate, consistent, coordinated, and sufficient for construction. HOWEVER, THE COUNTY MAKES NO REPRESENTATION OR WARRANTY OF ANY NATURE WHATSOEVER TO CONTRACTOR CONCERNING SUCH DOCUMENTS. By the execution hereof, Contractor acknowledges and represents that it has received, reviewed and carefully examined such documents, has found them to be complete, accurate, adequate, consistent, coordinated and sufficient for construction, and that Contractor has not, does not, and shall not rely upon any representation or warranties by the County concerning such documents as no such representation or warranties have been or are hereby made.

1.1.6 Any dispute relating to the Contract Documents, shall be resolved through good faith efforts upon the part of the Contractor and the County. Should Contractor have any questions concerning interpretation or clarification of the Contract Documents, Contractor shall submit to the County's Project Manager, in writing, a request for clarification that clearly and concisely sets forth the issues for which such request is sought. Such request shall be submitted to the Project Manager by the Contractor within three (3) business days of receipt of the Contract Documents, or the direction, interpretation, or clarification thereof provided by the County. The County's Project Manager shall render a determination concerning such interpretation or clarification, which shall be considered final and conclusive unless Contractor files a written protest within fourteen (14) calendar days of receipt thereof. Contractor's protest shall be submitted to the Assistant Director of Purchasing & Contracts, and shall state clearly and in detail the basis thereof. Failure by the Contractor to protest the County Project Manager's rendered determination within the timeframe above, shall constitute a waiver by the Contractor of all its rights to further protest, judicial, or otherwise. The Assistant Director of Purchasing & Contracts shall consider the Contractor's protest and shall render a decision thereon, in writing, within ten (10) calendar days. If Contractor does not agree with the determination of the Assistant Director of Purchasing & Contracts, the Contractor shall deliver written notice to that effect to the County within three (3) business days of receipt of the determination by the Assistant Director of Purchasing & Contracts.

1.1.7 Unless otherwise directed in writing, Contractor shall at all times carry on with the Work and maintain its progress schedule in accordance with the requirements of the Contract and the determination of the County, pending resolution of any Contract Document dispute. In no event will a dispute, the filing of a protest, claim or appeal, or the resolution or litigation thereof, relieve Contractor from its obligation to timely perform the Work required by the Contract and to maintain the progress schedule in accordance with the Contract.

1.1.8 Any and all Contract Documents shall remain the property of the County. Contractor is granted a limited license to use and reproduce applicable portions of the Contract Documents issued by the County appropriate to, and for use in, execution of the Work. Contractor shall have the right to keep one record set of the Contract Documents upon completion of the Work; provided, however, that in no event shall Contractor and/or its subcontractors use, or permit to be used, any or all of such Contract Documents on other projects without the specific written consent of the County.

1.2 Definitions

Terms used within this Agreement shall have the meaning as set forth in the St. Johns County Purchasing Policy, or as provided herein. Terms defined herein for specific application to this Contract shall govern over definition of terms provided in the St. Johns County Purchasing Policy.

1.2.1 Acceptance of the Work: Written acceptance of the Work by the County and the County's Project Manager.

1.2.2 Applicable Laws: All local, state, and federal laws, statutes, codes, ordinances, rules and regulations in effect at the time Work and Warranty Work is performed under this Contract.

1.2.3 Claim: Any claim, liability, loss, demand, demand for arbitration, damage, lien, cause of action of any kind, obligation, responsibility, cost, expense, royalty, fee, assessment, penalty, fine, judgment, interest or award, pending or threatened, whether arising by law, contract, tort, voluntary settlement or otherwise.

1.2.4 Contract Price: The sum set forth in Article IV of this Contract shall constitute the Contract Price, as may be

amended by Change Order. Unless otherwise approved by the County in writing, the Contract Price includes all taxes, including without limitation, income and withholding tax of any kind and sales tax imposed by the state or by the County and paid by Contractor or any Subcontractors with respect to sales of goods purchased for the performance of the Work.

1.2.5 Contract Time: The number of calendar days between commencement and completion of the Work, established in paragraph 3.1.1 of this Contract, as may be amended by Change Order.

1.2.6 Design: Those design services related to the Project prepared by the County or the County's consultants or other representatives, which shall, as may be required, be included in Contractor's Work.

1.2.7 Drawings: The graphic and pictorial portions of the Contract Documents, illustrating the design, location and dimensions of the Work, generally including but not limited to, plans, elevations, sections, details, general notes, schedules and diagrams.

1.2.8 Final Completion: Completion of all Work in compliance with the Contract Documents, as determined by the County, and issuance of a Final Certificate for Payment.

1.2.9 Force Majeure Events: Those events that are not reasonably foreseeable and are beyond the control of both the Contractor and the County, including acts of war, terrorist attacks, labor strikes, floods, earthquakes, epidemics, pandemics, riots, adverse weather conditions, and other acts of God.

1.2.10 Jobsite: Any physical location or other place on, under, in, at or through which any aspect of the Work is performed.

1.2.11 Notice to Proceed: A written notice given by the County to Contractor fixing the date on which the Contract Time will commence to run and identifying the corresponding Substantial Completion and Final Completion dates.

1.2.12 Product Data: Illustrations, standard schedules, performance charts, instructions, brochures, diagrams and other information furnished by Contractor to illustrate materials or equipment for some portion of the Work.

1.2.13 Project: The total undertaking to be accomplished for County by engineers, contractors, and others, including planning, study, design, construction, testing, commissioning, and start-up, and of which the Work to be performed under the Contract Documents is a part.

1.2.14 Project Manager: The County's representative assigned to the Project, or any part thereof, to observe the Work and perform certain other obligations of the County as defined in Article VI below.

1.2.15 Shop Drawings: Drawings, diagrams, schedules, and other data specially issued for the Work by Contractor or a Subcontractor, Sub-subcontractor, and material suppliers to illustrate some portion of the Work.

1.2.16 Specifications: That portion of the Contract Documents consisting of the written requirements for materials, standards, equipment, construction systems, and standards of workmanship for the Work, and performance of related services.

1.2.17 Subcontractor: A Subcontractor is an individual, partnership, corporation, association, joint-venture or any combination thereof, which has a direct or indirect contract with Contractor to perform a portion of the Work.

1.2.18 Substantial Completion: The stage in the progression of the Work when the Work is sufficiently complete in accordance with this Contract so that the County can enjoy beneficial use or occupancy of the Work and can utilize the Work for its intended purpose.

1.2.19 Work: Construction and services required by the Contract Documents, including all labor, materials, equipment and services as well as other deliverables provided, or to be provided, by Contractor to fulfill Contractor's obligations under this Contract. The Work may constitute the whole or part of the Project.

1.3 Ownership of Contract Documents

Any and all Contract Documents shall remain the property of the County. Contractor is granted a limited license to use and

reproduce applicable portions of the Contract Documents issued by the County appropriate to, and for use in, execution of the Work. Contractor shall have the right to keep one record set of the Contract Documents upon completion of the Work; provided, however, that in no event shall Contractor and/or Contractor's subcontractors use, or permit to be used, any or all of such Contract Documents on other projects without the specific written consent of the County.

ARTICLE II THE WORK

2.1 Project Description

The purpose of this project is to complete the 6-lane widening of CR 210 from Trinity Way to Beachwalk Boulevard, based on designed plans. This will include improvements of the roadway, drainage, signage, pavement markings and maintenance of traffic. All materials, equipment, tools and labor necessary to complete the work described in, and reasonably inferable from the plans, will be provided by the contractor.

2.2 Labor and Materials

2.2.1 Contractor shall perform all of the Work required, implied, or reasonably inferable from, the Contract Documents. Unless otherwise provided in the Contract Documents, Contractor shall provide and pay for all labor, supervision, materials, supplies, tools, transportation, storage, construction equipment and machinery, utilities (including but not limited to water, heat, fuel, light, and cooling), and all other services necessary for proper execution and completion of the Work, whether temporary or permanent and whether or not incorporated or to be incorporated in the Work. Materials, articles and equipment furnished by Contractor for incorporation into the Work shall be new unless otherwise specified in the Contract Documents.

2.2.2 Contractor shall use only competent and skilled personnel to perform and supervise the Work and shall remove from such Work any person determined to be unfit, unqualified, or acting in violation of any obligation of Contractor under this Contract. In the event a person is removed from the Work, Contractor shall promptly replace such individual with another who is fully competent and skilled to perform the Work at Contractor's sole expense.

2.2.3 Except as otherwise required for the safety or protection of persons or the Work or property at the Jobsite or adjacent thereto, and except as otherwise stated in the Contract Documents, all Work at the Jobsite shall be performed during regular working hours, Monday through Friday. Contractor will not perform Work on a Saturday, Sunday, or any legal holiday. Contractor may perform Work outside regular working hours or on Saturdays, Sundays, or legal holidays only with the County's prior written consent, which will not be unreasonably withheld.

2.2.4 In addition, when the Work requires by Florida Statute, Contractor shall use only licensed, registered and/or certified personnel to perform the Work. Such Statutes may include, but are not limited to, Chapter 489 (Regulation of Professions and Occupations Contracting) and Chapter 633, Part III (Fire Protection and Suppression) of the Florida Statutes.

2.3 Project Sequencing/Arrangement

Contractor shall not be limited in the sequencing or staging of the Work except to the extent that the Contract Documents impose limitations. Neither the organization of any of the Contract Documents into divisions, sections, paragraphs, articles, (or other categories), nor the organization/arrangement of the Drawings or Design, shall control Contractor in dividing the Work or in establishing the extent or scope of Work to be performed by Subcontractors.

2.4 Payment of Costs

Except as otherwise expressly provided, Contractor shall pay directly all costs and expenses of the Work of any kind or nature whatsoever including but not limited to all costs of permitting, regulatory compliance, obtaining and maintaining required bonds and insurance pursuant to Article 12, payments due to Subcontractors and suppliers, legal, financial, sales, use and similar taxes on materials and equipment, transportation and storage of materials and equipment, preparation of schedules, budgets and reports and all other costs required to achieve Substantial Completion and Final Completion in accordance with the Contract Documents.

2.5 Cleaning the Jobsite

Contractor shall keep the Jobsite neat, secure and orderly during performance of the Work and shall clean up and remove all waste, rubbish and construction debris from the Jobsite as they accumulate. Upon Final Completion of the Work, Contractor shall remove all waste, rubbish and construction debris from and about the Jobsite as well as all tools, appliances, construction equipment, temporary utilities, temporary construction and machinery and surplus materials. Contractor shall restore to original condition all property not designated for alteration by the Contract Documents.

2.6 Reporting Requirements

2.6.1 Daily Record. The Contractor shall keep a daily record of the Work at the Jobsite. At a minimum the Daily Record shall include weather conditions, number of workers (by trade) on the Jobsite, and material/equipment deliveries. Daily Records shall be submitted by close of business the following day.

2.6.2 Monthly Report. The Contractor shall prepare and submit a written monthly report by the tenth day of each calendar month. Monthly reports shall at a minimum describe Work completed in the prior month, planned Work for the current month, detailed explanations of any activity that is behind schedule, corrective actions taken to recover schedule, safety and environmental incidents and corrective actions taken.

2.7 Title and Risk of Loss

Title to the structures, improvements, fixtures, machinery, equipment and materials constituting the Work or the Project shall pass to the County no later than time of payment. Such transferred title shall in each case be good, free and clear of any and all security interests, liens or other encumbrances. Contractor shall, however, bear all risk of loss concerning such structures, improvements, fixtures, machinery, equipment and materials until Substantial Completion, regardless of the extent to which the loss was insured or the availability of insurance proceeds. The transfer of title does not imply acceptance by the County nor does it relieve Contractor from the responsibility for any loss or damage to items.

2.8 Access to Work

The County and the Project Manager, shall at all reasonable times have full access to all parts and locations of the Jobsite(s) from commencement of the Work through Final Completion. Contractor shall take whatever steps necessary to provide such access when requested.

2.9 Utilities

Contractor shall, at its expense, make all arrangements necessary to secure the availability of and maintain all temporary utilities required to construct and operate Contractor's Work as required by the Contract Documents. If the scope of Work requires, Contractor shall arrange for activating permanent power, water, and sanitary service to the Project prior to Substantial Completion. This includes legal sketches and descriptions for easement as well as record drawings requirements required by utility companies. The County will assume permanent utility costs at Substantial Completion.

2.10 Existing Utility Lines

2.10.1 When existing Utility Lines (e.g. conduits, pipelines, transmission mains and utility equipment and appurtenances) shown on the Drawings are to be removed or relocated, Contractor shall notify the Project Manager in ample time (but in no event less than five (5) business days) for taking measures for prevention of the interruption of any required services prior to the beginning of operations. Locations of existing utility lines shown on the Drawings are based on the best information available to the Project Manager, but shall not be considered exact either as to location or number of such lines.

2.10.2 Contractor shall protect Utility Lines constructed under terms of the Contract and those discovered or shown on Drawings to be existing. In the event that Contractor damages any existing Utility Lines, shown or not shown on the Drawings, Contractor shall immediately notify the Project Manager. Damage occurring to existing Utility Lines due to Contractor's failure to exercise reasonable care shall be repaired or replaced at no cost to the County.

2.11 Taxes

2.11.1 Contractor shall pay all taxes, levies, duties and assessments of every nature which may be applicable to any Work under this Contract. The Contract Price and any agreed variations thereof shall include all applicable taxes imposed by law. Contractor shall make any and all payroll deductions required by law. Contractor herein indemnifies and holds the County harmless from any liability on account of any and all such taxes, levies, duties, assessments and deductions. The indemnity provision of this section shall survive the expiration or earlier termination of this Contract. Contractor may not use County's tax-exempt status unless specifically authorized in writing in advance.

2.11.2 Foreign Entity Tax Withholding. Amounts due to certain foreign persons or entities may be subject to backup withholding taxes under federal law. If Contractor is a foreign person or entity that is required to complete Internal Revenue Service ("IRS") Form W-8ECI, Contractor shall provide County a copy of Contractor's current Form W-8ECI prior to issuance of any invoice or payment under this Contract. If Contractor fails to timely provide a completed, current Form W-8ECI, County will withhold all backup withholding taxes from the amounts due to the Contractor, remit such sums to the

IRS, and pay Contractor only the remainder. County makes no representation regarding the tax treatment of amounts due to Contractor, and Contractor releases and holds the County harmless from any claims or damages in any way relating to or arising from any tax withholding by County pursuant to this section.

2.12 Publicity and Advertising

2.12.1 Contractor shall not make any announcement or release any information or publish any photographs concerning this Contract, the Work or the Project or any part thereof to any member of the public, press or any official body, unless prior written consent is obtained from the County.

2.12.2 Use of the County Seal or County Logo is strictly prohibited. In accordance with, County Ordinance 92-2 and County Administrative Policy 101.3, Contractor may not manufacture, use, display, or otherwise use any facsimile or reproduction of the County Seal or Logo without express written approval of the Board of County Commissioners of St. Johns County, Florida.

2.13 County Furnished Items

2.13.1 The County shall furnish to Contractor, at the time of executing this Contract, written and tangible material concerning conditions below ground at the Jobsite. Such written and tangible material is furnished to Contractor only in order to make disclosure of such material and for no other purpose. By furnishing such material, the County does not represent, warrant, or guarantee its accuracy either in whole, in part, implicitly, or at all, and shall have no liability therefore. The County shall also furnish surveys, legal limitations and utility locations (if known), and a legal description of the Project's Jobsite.

2.13.2 Contractor shall obtain and pay for all permits, fees and licenses necessary and ordinary for the performance of the Work. Excluding such permits, fees and licenses, the County shall obtain all approvals, easements, and the like required for construction.

2.13.3 Subject to Paragraph 1.6 above, the County shall furnish Contractor electronic copies of the Contract Documents for execution of the Work. Hard copies of the Contract Documents shall be the responsibility of Contractor.

ARTICLE III CONTRACT TIME

3.1 Contract Time

3.1.1 Contractor shall commence the Work within ten (10) calendar days following receipt of the County's Notice to Proceed and shall substantially complete all Work within **five hundred eighteen (518)** consecutive calendar days as may be extended pursuant to Paragraph 9.2 of this Contract. Final Completion shall be reached within **thirty (30)** consecutive calendar days after Substantial Completion.

3.1.2 Contractor, prior to commencing the Work, shall submit to the Project Manager for his/her information, Contractor's schedule for completing the Work. Contractor's schedule shall be revised no less frequently than monthly (unless the parties otherwise agree in writing), and relate to the entire Work. By way of illustration and not exclusion, Contractor's schedule shall: (1) contain sufficient activities to assure adequate planning for the Work, (2) include approved changes to the Work that impact the schedule, (3) include a clearly defined critical path, and (4) include a unique description for each activity. In the event any schedule revision impacts the completion time as provided in Paragraph 3.1.1 above, Contractor shall submit a request for additional time, in accordance with procedures as provided in Paragraph 9.2 below. Failure by Contractor to strictly comply with the provisions of this Paragraph shall constitute a material breach of this Contract.

3.2 Time is of the Essence

Time is of the essence regarding each and every obligation of Contractor under this Contract. Each obligation is deemed material, and a breach of any such obligation (including a breach resulting from untimely performance) is a material breach.

3.3 Substantial Completion

3.3.1 When Contractor considers the Work is substantially complete, Contractor shall notify the Project Manager in writing and submit a comprehensive list of incomplete items to be completed or corrected prior to Final Completion. The Project Manager will promptly inspect the Work following receipt of Contractor's notice and attached list of incomplete

items. The Project Manager may refuse to inspect the Work if the Work is obviously not substantially complete or when Contractor's list is not complete.

3.3.2 To the extent applicable to Contractor's specific Work scope, the following items shall be completed prior to Contractor's request for a Substantial Completion inspection.

- a) All general construction completed.
- b) Project Jobsite cleared of Contractor's excess equipment, storage shacks, trailers, and/or building supplies.
- c) Project record Drawings and Specifications submitted in accordance with the Contract Documents.
- d) Preliminary as-built drawings submitted.
- e) All applicable permits required for use provided.
- g) All operations and maintenance manuals, training literature, and software for all equipment provided.
- h) Manufacturers' certifications and warranties provided.
- i) All required spare parts and special tools provided.

3.3.3 If Substantial Completion is not obtained at the inspection called by Contractor, for reasons which are the fault of Contractor, the cost of any subsequent inspections requested by Contractor for the purpose of determining Substantial Completion shall be the responsibility of Contractor and shall be assessed against the final payment application.

3.3.4 Once Substantial Completion is achieved and within the time allowed by F.S. 218.70 et seq, the Project Manager will prepare the punch list required by the Local Government Prompt Payment Act. Unless otherwise mutually agreed, the punch list items shall be corrected by Contractor within thirty (30) calendar days and prior to any request for Final Inspection and Acceptance. The failure to include any corrective Work or pending items not yet completed on the list does not alter the responsibility of Contractor to complete the Work pursuant to this Contract.

3.4 Final Inspection

When all the Work is finally complete and Contractor is ready for a final inspection, Contractor shall provide written notice to the County and the Project Manager. The Project Manager, with Contractor's cooperation, will conduct such reviews, inspections and tests as may be reasonably required to satisfy the County that the Work, or identified portion of the Work, conforms to all requirements of the Contract Documents. If the Project Manager determines that the Work or any part of the Work is not complete or fails to conform to the Contract Document requirements, Contractor will be notified in writing of deficiencies. After correcting all deficiencies Contractor shall again initiate the procedures for final inspection as set forth above. The Project Manager will issue a Final Certificate for Payment following satisfactory inspection of the Work provided Contractor has delivered to the Project Manager the final corrected as-built Drawings and the final bill of materials, if any.

3.5 Liquidated Damages

3.5.1 Execution of this Contract by Contractor shall constitute Contractor's acknowledgment that the County will sustain damages in the amount identified in Paragraph 3.5.2 below for each and every calendar day during which completion of the Work required is delayed beyond Final Completion. Contractor and County agree that such damages shall be presumed to be the damages actually sustained by the County as defined below, and that because of the nature of the Project, it would be impracticable or impossible to determine or extremely difficult to fix the actual damages.

3.5.2 If Contractor fails to achieve Substantial Completion or Final Completion of the Work by its applicable date, then the County shall be entitled to withhold from any amounts otherwise due Contractor or to be paid as a debt due the sum of **\$4,687** per day for each and every calendar day of unexcused delay "Liquidated Damages". The parties agree that such Liquidated Damages are not a penalty but rather a genuine pre-estimate of monetary damages sustained by the County for loss of revenue and/or increased project administration expenses related to this Contract because Contractor failed to perform and complete Work within the time fixed for completion or additional time granted pursuant to the provisions hereof. The assessment of Liquidated Damages are without prejudice to the County's rights of termination and Contractor's obligation to complete the Work.

3.5.3 Should Contractor fall behind the approved Work schedule; the County reserves the right to deduct Liquidated Damages based on an estimated period of late completion. The County need not wait until completion of Work to withhold Liquidated Damages from Contractor's progress payments.

3.6 Disclaimer of Consequential Damages

The County shall not be liable to Contractor, whether in contract, tort, warranty or under any statute or on any other basis, for any consequential, incidental, indirect, special, punitive or exemplary damages suffered or incurred by Contractor in connection with this Contract, even if the County has been advised of the possibility of such damages. Consequential damages shall include, by way of example and without limitation, opportunity costs, loss of use of facilities or other assets, consequential damage claims of subcontractors, lost profits, lost savings, lost business, lost bonding capacity, lost financing, lost reputation or lost goodwill.

ARTICLE IV CONTRACT PRICE AND PAYMENT

4.1 Contract Price

4.1.1 This Contract is a LUMP SUM Contract. As compensation for satisfactory performance of the Work, the County shall compensate, and Contractor shall accept, as full and complete compensation for all the Work required herein a total lump sum of **Twelve Million Five Hundred Eighty-Six Thousand Six Hundred Thirty-One Dollars and Five Cents (\$12,586,631.05)**, which includes a lump sum of \$11,811,550.05 for the Base Bid, and a lump sum of \$775,081.00 for Alternate #1 for the Temporary Traffic Control Plan, together comprise the "Contract Price". The cost of any item of Work not covered by a specific Lump Sum shall be included in the Lump Sum price to which the item is most applicable.

4.1.2 If required by the County, Contractor shall have included unit prices in the base Lump Sum. Such unit prices shall apply to revisions to the Work as directed by the County in accordance with Article IX. Unit prices are "all-inclusive", including labor, material, supervision, tools, equipment, insurance, taxes, fringe benefits, coordination, engineering, overhead, profit, performance and payment bonds, and all other things necessary. Unit prices are fixed for the duration of the Contract and are not subject to escalation for any cause.

4.2 Schedule of Values

4.2.1 Prior to the commencement of Work, Contractor shall submit to the County and to the Project Manager a Schedule of Values allocating the Contract Price to the various portions of the Work. Contractor's Schedule of Values shall be prepared in such form, with such detail, and supported by such data as the Project Manager or the County may require to substantiate its accuracy. Contractor shall not imbalance the Schedule of Values nor artificially inflate any element thereof. The violation of this provision by Contractor shall constitute a material breach of this Contract.

4.2.2 Upon approval by the County the Schedule of Values shall be used as a basis for Contractor's Application for Payment. The total of all payments in the Schedule of Values must at all times be equal to the Contract Price. No progress payment shall be made to Contractor until an acceptable Schedule of Values is submitted.

4.2.3 General conditions costs may be considered as a line item for the following items (break down required) (collectively the following shall be known as the General Conditions Costs):

- a) Contractor's field office personnel (full-time on-site)
- b) Construction office and storage facilities
- c) Utilities required to sustain field office and sanitary facilities
- d) Electrical power and water for construction
- e) Bonds and Insurance

4.2.4 Progress payments for general conditions costs will be based on the percentage of Work completed to date, except bonds and insurance which may be requested in full. Separate payments for Shop Drawings and deposits for materials will not be allowed.

4.3 Measurement and Payment

4.3.1 Contractor shall make all surveys necessary for determining all quantities of Work to be paid under this Contract. Copies of field notes, computations and other records made by Contractor for the purpose of determining quantities shall be furnished to the Project Manager upon request. Contractor shall notify the Project Manager prior to the time such surveys are made. The Project Manager may but shall have no obligation to witness and verify such surveys. Measurements and computations shall be made by such methods as the County may consider appropriate for the class of work measured. The dividing limits, lines or planes between adjacent items or classes of excavation, concrete, or other types of Work where not definitely indicated on the Drawings or in the Specifications shall be as determined by the County.

4.3.2 No payments of invoices (or portions thereof) shall, at any time, constitute approval or acceptance of the Work under this Contract, nor be a waiver by the County of any of the terms contained herein.

4.4 Progress Payments

4.4.1 Prior to Contractor's submittal of the initial Application for Payment, Contractor shall have delivered the following documents. The County will not make any payment to Contractor until Contractor has complied with these requirements.

- a) Schedule of Values
- b) Project Schedule
- c) Certified copy of recorded bond
- d) Insurance Certificates

4.4.2 On or before the tenth (10th) day of each calendar month, Contractor shall submit an Application for Payment to the Project Manager in such form and manner, and with such supporting data and content, as the Project Manager may require. Such Application for Payment shall be based on the amount of Work done or completed during the payment period which is defined as the first day of the preceding calendar month through the last day of the preceding calendar month. The Project Manager will review the Application for Payment to determine whether the quantity and quality of the Work is as represented in the Application for Payment and thereafter confirm to the County the amount properly owing to Contractor. Upon receipt by the County of the Project Manager's recommendation for payment, payments will be made in accordance with the Local Government Prompt Payment Act (Sections 218.70-218.80 of the Florida Statutes) less such amounts, if any, otherwise owing by Contractor to the County or which the County shall have the right to withhold. Any Application for Payment determined by the County not to be suitable for payment shall be modified and processed in accordance with the County's assessment.

4.4.3 In the event any dispute with respect to any payment or Application for Payment cannot be resolved between Contractor and the County's Project staff, Contractor may demand in writing a meeting with and review by the County's Assistant Director of Purchasing and Contracts. Such meeting and review shall occur within ten (10) business days of receipt by the County of Contractor's written demand. The Assistant Director of Purchasing and Contracts shall issue a written decision on the dispute within ten (10) business days of such meeting. This decision shall be deemed the County's final decision for the purpose of the Local Government Prompt Payment Act.

4.4.4 The County may withhold from each progress payment made to Contractor an amount not to exceed five (5%) percent of payment as retainage until final acceptance of all Work in accordance with Section 255.078 of the Florida Statutes. Any interest earned on retainage shall accrue to the benefit of the County. The County shall make prompt payment to Contractor, unless in accordance with Section 255.078(6) of the Florida Statutes, such funds are the subject of a good faith dispute, claim or demand by the County or Contractor.

4.4.5 Contractor warrants and guarantees that title to Work, materials, and equipment covered in any Application for Payment, whether incorporated in the Project or not, shall pass to the County no later than the time of payment and shall be free and clear of liens, claims, security interests or other encumbrances.

4.5 Application for Payment

4.5.1 Contractor may make Application for Payment, at intervals of not more than once a month for Work satisfactorily completed during the Project. Contractor shall submit with each Application for Payment an updated Project schedule acceptable to the Project Manager. Each Application for Payment shall clearly include:

- a) Contract Number;
- b) A unique Application for Payment number;
- c) Contractor's legal name and address;
- d) Taxpayer identification number (Contractor's federal employer identification number);
- e) Brief description of the completed Work, in accordance with Contractor's Schedule of Values;
- f) Original Contract Price including approved Change Order amounts; and,
- g) Preferred remittance address, if different from the mailing address.

The County may require any other information from Contractor that the County deems necessary to verify Contractor's Application for Payment. No later than ten (10) days after execution of this Contract or Notice to Proceed has been issued,

the County will identify in a separate written notice the submittal requirements for Contractor's payment requests.

4.5.2 Delivered, stored or stockpiled materials may be included in an Application for Payment provided Contractor meets the following conditions:

- a) Materials are suitably and securely stored at the Jobsite or a bonded warehouse (acceptable to the County);
- b) An applicable purchase order or supplier's invoice is provided listing the materials in detail, cost of materials and identifying this specific Project by name; and
- c) The material is insured against loss or damage (from whatever source) or disappearance prior to incorporation into the Work.

Payments for such materials shall be at the sole discretion of the Project Manager, shall be based only upon the actual cost of the materials to Contractor, and shall not include any overhead or profit to Contractor.

4.5.3 Each Application for Payment shall be signed by Contractor and shall constitute Contractor's representation that the Work has progressed to the level for which payment is requested, that the Work has been properly installed or performed in full accordance with this Contract, and that Contractor knows of no reason why payment should not be made as requested. Contractor's final Application for Payment shall also be accompanied by a full and complete release and/or waiver of all liens complying with Section 713.20 of the Florida Statutes.

4.5.4 Contractor must remit undisputed payment due for labor, services, or materials furnished by Subcontractors and suppliers hired by Contractor, within ten (10) days after receipt of each progress payment from the County pursuant to Section 218.735 of the Florida Statutes. If necessary for the protection of the County, the County shall have the right, at its sole option, to make payment by joint check or by direct check to Contractor's Subcontractors or suppliers without advance notice to or consent of Contractor. If joint checks are issued following claims by Contractor's Subcontractors or suppliers, the County shall be entitled to an administrative fee of \$50.00 per check for the expense of processing each joint check. Any amounts paid directly to a Subcontractor or supplier will be deducted from payments made to, or amounts due or that may become due to, Contractor. The issuance of a joint check shall create no rights in favor of any person or entity beyond the right of the named payees to payment of the check and shall not be deemed to commit the County to repeat the procedure in the future.

4.5.5 No progress payment, nor any use or occupancy of the Project by the County, shall be interpreted to constitute approval or acceptance of any Work under this Contract, nor be considered a waiver by Contractor of any of the terms of this Contract.

4.5.6 The County's performance and obligation to pay under this Contract is contingent upon an appropriation of lawfully available funds by the Board of County Commissioners. The County shall promptly notify Contractor if the necessary appropriation is not made.

4.6 Withheld Payment

4.6.1 The County may decline to make payment, may withhold funds otherwise payable and, if necessary, may demand the return of some or all of the amounts previously paid to Contractor, if:

- a) Any Claims are made against Contractor by the County or third parties, including Claims for liquidated damages or if reasonable evidence indicates the probability of the making of any such Claim;
- b) Any Claims are made against the County, the County's property or any other party indemnified hereunder which is or might be covered by Contractors Indemnification obligations under Section 11.2 below;
- c) Contractor fails to pay Subcontractors or others in full and on-time;
- d) Contractor fails to submit schedules, reports, or other information required under the Contract;
- e) Contractor fails to diligently prosecute the Work and maintain progress to assure completion within the Contract Time;
- f) Contractor persistently fails to fully and timely perform the Work in accordance with the Contract Documents;
- g) Defective or nonconforming Work is not remedied; or
- h) Contractor is in default of any other representation, warranty, covenant or performance obligation of this Contract.

4.6.2 If Claims or liens filed against Contractor or property of the County connected with performance under this Contract are not promptly removed by Contractor after receipt of written notice from the County to do so, the County may remove such Claims or liens and all costs in connection with such removal shall be deducted from withheld payments or other monies due, or which may become due, to Contractor. If the amount of such withheld payments or other monies due Contractor under the Contract is insufficient to meet such cost, or if any Claim or lien against Contractor is discharged by the County after final payment is made, Contractor and its surety or sureties shall promptly pay the County all costs (including attorney's fees) incurred thereby regardless of when such Claim or lien arose.

4.7 Final Payment

4.7.1 Upon Contractor's receipt of the Final Certificate for Payment, Contractor may submit a final invoice provided the following has been completed or submitted with such final invoice:

- a) Complete all items applicable to the Work identified in Paragraph 3.3.2;
- b) Complete all Work listed on the punch list prepared in accordance with Paragraph 3.3.4;
- c) Consent of Surety for final payment and/or retainage;
- d) Final Waiver and Release of Claim signed by Contractor;
- e) Submittal of final corrected as-built (record) Drawings;
- f) Settlement of Liquidated Damages, as applicable; and
- g) Settlement of liens and Claims, if any.

4.7.2 Acceptance of Final Payment shall constitute a waiver of all Claims against the County by Contractor except for those Claims previously made in writing against the County by Contractor, pending at the time of Final Payment, and identified in writing by Contractor as unsettled at the time of its request for Final Payment.

4.7.3 In the event Contractor fails to make a Request for Final Payment, or to resubmit a final Application for Payment within ninety (90) days after being requested to do so, the County may deem any and all retained funds to be abandoned property and shall give notice of abandonment to Contractor. The County may set off against the final payment any amounts due to County from Contractor arising out of or under this or any other Contract or Contract between them.

ARTICLE V CONTRACTOR RESPONSIBILITIES

5.1 Performance

5.1.1 Contractor warrants that, to the best of its knowledge, there is no pending or threatened action, proceeding, or investigation, or any other legal or financial condition, that would in any way prohibit, restrain, or diminish Contractor's ability to satisfy its contractual obligations hereunder.

5.1.2 Contractor shall perform no part of the Work at any time without adequate Contract Documents or, as appropriate, approved Shop Drawings, Product Data or samples for such portion of the Work. If Contractor performs any portion of the Work where Contractor knows or should know such Work involves a recognized error, inconsistency or omission in the Contract Documents without notice to the Project Manager and the County, Contractor shall bear responsibility for such performance and shall bear the cost of correction.

5.1.3 Contractor shall perform the Work strictly in accordance with this Contract.

5.1.4 Contractor shall confine its operations to the Jobsite or such other land and areas identified in and permitted by the Contract Documents. Contractor shall assume full responsibility for any damage to any such land or area, to the County or occupant thereof, or of any adjacent land or areas, resulting from the performance of the Work. Should any Claim be made by any such owner or occupant because of the performance of the Work, Contractor shall promptly settle with such other party by negotiation or otherwise resolve the Claim by other dispute resolution proceeding or at law. Contractor shall, to the fullest extent permitted by Applicable Law, indemnify and hold harmless the County, and its officers, directors, agents and employees and anyone directly or indirectly employed by them from and against Claims, costs, losses, and damages arising out of or resulting from any Claim or action, legal or equitable, brought by any such owner or occupant against the County or any other party indemnified hereunder to the extent caused by or based upon Contractor's or a Subcontractor's performance of the Work.

5.1.5 Contractor is solely and exclusively responsible for supervising all workers at the Jobsite. Contractor shall supervise and direct the Work using Contractor's best skill, effort and attention. Contractor shall be responsible to the County for any

and all acts or omissions of Contractor, its employees and others engaged in the Work on behalf of Contractor.

5.1.6 Contractor and the Work must comply with all Applicable Law and the requirements of any applicable grant agreements.

5.2 Authorized Representative

5.2.1 Prior to commencing Work, Contractor shall designate in writing a competent, authorized representative(s) acceptable to the County to represent and act for Contractor (“Authorized Representative”). Absent such written designation, Contractor’s Jobsite superintendent shall be deemed Contractor’s Authorized Representative and s/he shall be authorized to receive and accept any and all communications from the County or the County’s Project Manager. All communications given to the Authorized Representative shall be binding upon Contractor. An Authorized Representative may be added, removed or changed upon prior written notice given pursuant to Section 13.18 titled “Written Notice”.

5.2.2 At all times while performing the Work and Warranty Work, Contractor shall have one or more Authorized Representatives present on the Jobsite. Such Authorized Representative shall be capable to effectively communicate with the County or the County’s Project Manager, execute and enforce applicable Contract Documents and address Jobsite safety and environmental requirements.

5.3 Environmental, Safety and Health

5.3.1 Safety and Protection. Contractor shall be solely and exclusively responsible for conducting operations under this Contract to avoid risk of harm to the health and safety of persons and property and for inspecting, supervising and monitoring all equipment, materials (whether in storage on or off the Jobsite), work practices and safety precautions (including but not limited to adequate maintenance of traffic) used in the Work to ensure compliance with its obligations under this Contract. Contractor shall provide or cause to be provided necessary training and furnish all safety construction equipment/tools, including OSHA compliant and ANSI certified personal protective equipment as appropriate and necessary for the performance of the Work, to its subcontractors of every tier and enforce the use of such training and safety construction equipment/tools.

5.3.2 Compliance. Contractor shall comply with all Applicable Laws bearing on the safety of persons or property, or their protection from damage, injury or loss including compliance with applicable permits, Project plans and approvals. To the extent allowed by law, Contractor shall assume all responsibility and liability with respect to all matters regarding the safety and health of its employees and the employees of Contractor’s subcontractors and suppliers of any tier, with respect to the Work.

5.3.3 Stop Work Authority. Notwithstanding the foregoing, the County reserves the right to direct Contractor to stop Work and correct an unsafe condition at any time that any person present at the Jobsite identifies any unsafe condition or action. For this purpose only, any person at the Jobsite is authorized to act on behalf of the County.

5.3.4 Safety Representative. Prior to commencing Work, Contractor shall designate in writing a member(s) of its Jobsite construction team as its Safety Representative. Such Safety Representative shall be acceptable to the County and shall have responsibility for implementing all safety procedures, including OSHA, responsibility for the prevention of accidents, authority for monitoring safety of the Work, authority to correct unsafe conditions or acts by its employees or Subcontractors, the ability to oversee compliance with and address environmental requirements, and coordinate with other on-site contractors and subcontractors on safety and environmental matters required for the Work. In the absence of the required written designation, this person shall be Contractor’s Superintendent.

5.3.5 Safety Reporting Requirements. Contractor shall maintain accident and injury records as required by Applicable Law. Such records will be made available to the County upon request. Contractor shall immediately report to the County any death, injury or damage to property incurred or caused by Contractor’s employees and employees of Contractor’s subcontractors and suppliers of any tier.

5.3.6 Drug Free Workplace. By signing this Contract, Contractor agrees to maintain a healthy and productive workforce and safe working conditions thru compliance with the Drug-Free Workplace Act (Chapter 112, Florida State Statutes). Contractor’s personnel shall not possess, use, manufacture, distribute or be under the influence of while on the Jobsite (or any other location where the provisions of this Contract applies) alcoholic beverages and/or illegal drugs or any other “Drug” as such term is defined in the Drug-Free Workplace Act.

5.3.7 Occupational Safety and Health Act (OSHA). Contractor warrants that all materials, equipment, services, etc., delivered or provided to the County shall conform in all respects to the standards set forth in the Occupational Safety and Health Act (OSHA) of 1970 as amended and the failure to comply will be considered a breach of this Contract. Contractor further certifies that if material, equipment, service, etc., delivered or provided to the County is subsequently found to be deficient in any OSHA requirement in effect on date of delivery or service fulfillment date, all costs necessary to bring the material, equipment, service, etc., into compliance with the aforementioned requirements shall be borne by Contractor.

5.3.8 Toxic Substances/Federal Hazard Communication “Right to Know and Understand” Regulations
The Federal “Right to Know and Understand” Regulation (also known as the Hazard Communication / Globally Harmonized System of Classification and Labeling of Chemicals (GHS) implemented by OSHA requires employers to inform their employees of any toxic substances to which they may be exposed in the workplace, and to provide training in safe chemical storage, labeling, handling practices and emergency procedures.

Accordingly, Contractor is required to provide completed Safety Data Sheets (SDS) for each hazardous substance provided to the County under this Contract. This includes hazardous substances that are not directly included in the Contract Documents, but are included in the goods or services provided by Contractor to the County. The SDS for each substance must be sent to the County’s Project Manager and must also be sent to:

St. Johns County, a political subdivision of the State of Florida
500 San Sebastian View
St. Augustine, FL 32084
Attn: Risk Management

In the event that hazardous material is improperly handled or stored by Contractor, its subcontractors, any sub-subcontractors, or any employee or agent of any of the aforementioned which results in contamination of the Jobsite, Contractor shall immediately notify the County and the appropriate governmental authority and shall take whatever action is necessary or desirable to remediate the contamination at Contractor’s sole cost and expense. Further, Contractor shall indemnify and hold harmless the County from any and all cost, expense, action, or liability whatsoever resulting from such contamination and/or remedial activities. The indemnity provisions of this section shall survive the expiration or earlier termination of this Contract.

ARTICLE VI PROJECT MANAGER

6.1 Project Manager Responsibilities

6.1.1 The County shall designate as its representative a Project Manager who shall be fully acquainted with the Project. The Project Manager shall be the County’s representative from the Effective Date of this Contract until final payment has been made. The Project Manager shall be authorized to act on behalf of the County only to the extent provided in this Article VI.

6.1.2 The County and Contractor shall communicate with each other in the first instance through the Project Manager.

6.1.3 The Project Manager shall be the initial interpreter of the requirements of the Drawings and Specifications and the judge of the performance there under by Contractor. The Project Manager shall render written or graphic interpretations necessary for the proper execution or progress of the Work with reasonable promptness on request of Contractor.

6.1.4 The Project Manager shall review Contractor’s Applications for Payment and shall confirm to the County for payment to Contractor, those amounts then due to Contractor as provided in this Contract.

6.1.5 The Project Manager shall have authority to reject Work, which is defective or does not conform to the requirements of this Contract. If the Project Manager deems it necessary or advisable, the Project Manager shall have authority to require additional inspection or testing of the Work for compliance with Contract requirements at Contractor’s expense.

6.1.6 The Project Manager shall review and accept, or take other appropriate action as necessary, concerning Contractor’s submittals including but not limited to Shop Drawings, Product Data and Samples. Such review, acceptance or other action shall be for the sole purpose of determining conformance with the design concept and information given through the

Contract Documents.

6.1.7 The Project Manager may authorize minor changes in the Work by field order as provided elsewhere herein. The Project Manager does not have authority to approve adjustments to the Contract Price or Contract Time. If at any time Contractor believes that acts or omissions of the County constitute a change to the Work, Contractor shall submit a written notice in accordance with the requirements of Article VIII.

6.1.8 The Project Manager shall, upon written request from Contractor, conduct inspections to determine the date of Substantial Completion and the date of Final Completion, shall receive and forward to the County for the County's review and records, written warranties and related documents required by this Contract and shall issue a Final Certificate for Payment upon compliance with the requirements of this Contract.

6.1.9 The Project Manager's decision in matters relating to aesthetic effect shall be final if consistent with the intent of this Contract.

6.2 Field Orders

The Project Manager shall have authority to order minor changes in the Work not involving a change in the Contract Price or Contract Time and not inconsistent with the intent of this Contract. Such changes shall be affected by written field order and shall be binding upon Contractor. Contractor shall carry out such field orders promptly.

ARTICLE VII SUBCONTRACTORS

7.1 Award of Subcontracts

7.1.1 Contractor shall be responsible for all Work performed under the Contract Documents. All persons engaged in the Work of the Project are the responsibility and under the control of Contractor. Contractor shall furnish the Project Manager, in writing, the names of persons or entities proposed by Contractor to act as a Subcontractor on the Project. The Project Manager shall promptly reply to Contractor, in writing, stating any objections the Project Manager may have to such proposed Subcontractor. Contractor shall not enter into a Subcontract with a proposed Subcontractor with reference to whom the Project Manager has made a timely objection.

7.1.2 Contractor shall give personal attention to fulfillment of the Contract and shall keep the Work under Contractor's control. When any Subcontractor fails to execute a portion of the Work in a manner satisfactory to the County, Contractor shall remove such Subcontractor immediately upon written request from the County, and the Subcontractor shall not again be employed on the Project. The County will not entertain requests to arbitrate disputes among Subcontractors or between Contractor and Subcontractor(s) concerning responsibility for performing any part of the Work.

ARTICLE VIII CONTRACT DISPUTES/CLAIMS

8.1 Contract Claims

8.1.1 If any dispute between the County and Contractor arises under this Contract and such dispute cannot be resolved by good faith negotiations at the field level between the Project Managers of the Contractor and County, such dispute shall be promptly escalated to the Senior Representatives of the Parties, upon request of either party, who shall meet as soon as conveniently possible, but in no case later than fourteen (14) calendar days after such a request is made, to attempt to resolve such dispute or disagreement. Five (5) calendar days prior to any meetings between the Senior Representatives, the parties will exchange relevant information that will assist the parties in resolving the dispute or disagreement.

8.1.1.1 The Senior Representative for the County shall be the Director, or designee, of the County's Public Works Department.

8.1.1.2 The Senior Representative for the Contractor shall be the supervisor of the Project Manager, or a principal of the Contractor.

8.1.2 If after meeting, the Senior Representatives determine that the dispute or disagreement cannot be resolved on terms satisfactory to both parties, the Contractor shall submit a Contract Claim as provided herein.

8.1.3 Prior to filing a Contract Claim, Contractor shall first exhaust all remedies set forth in the Contract Documents.

Claims arising from this Contract shall be filed with the Assistant Director of Purchasing & Contracts within five (5) business days of exhausting all remedies set forth above. Pending final resolution of a dispute or claim, unless otherwise agreed in writing by both parties, the Contractor is required to proceed with performance of the Work and maintain effective progress to complete the Work within the Contract Time set forth herein. The Contract Claim shall include, at a minimum, the following:

- a) The name and address of the Contractor and any legal counsel; and
- b) The Contractor's address to which the County's rendered decisions shall be sent; and
- c) Identification, and a copy, of the final adverse decision or document that is the subject of the Contract Claim and any exhibits, evidence or documents which the Contractor deems applicable to the issues raised in the Claim; and
- d) Identification of the administrative remedies provided for in the Contract that were pursued prior to the Claim and the outcome; and
- e) A statement of the grounds for each issue raised in the Contract Claim to be reviewed and the applicable provisions of the Contract, as well as any applicable Laws, or other legal authorities which the Contractor deems applicable to the Claim.

8.1.4 During the Assistant Director of Purchasing & Contracts' review of the Contract Claim, the Assistant Director of Purchasing & Contracts may request additional information from the project team of both parties. The parties must provide the requested information within the time period set forth in the request. Failure of either party to timely comply may result in resolution of the Claim without consideration of the requested information.

8.1.5 The Assistant Director of Purchasing & Contracts shall render a decision on the Contract Claim within twenty-one (21) calendar days of the deadline for receipt of all requested information. The written decision of the Assistant Director of Purchasing & Contracts shall be sent to the Contractor at the address provided in the Contract Claim, or as otherwise agreed to by the parties.

8.1.6 The decision for any Contract Claim by the Assistant Director of Purchasing & Contracts may be appealed by the Contractor to the County Administrator. Contractor must submit their appeal to the County Administrator, including any and all information, documentation, backup data, or other supplemental facts or figures within five (5) business days of receipt of the Assistant Director of Purchasing & Contracts' decision. Failure by the Contractor to submit an appeal within the prescribed timeframe shall be a waiver of a right to appeal the rendered decision. The appeal shall include any and all information, documentation, and data relative to the Contract Claim and subsequent appeal. The County Administrator shall render a decision within thirty (30) calendar days of receipt of all information. The County Administrator's decision shall be considered final, unless Contractor takes legal action in Circuit Court.

ARTICLE IX CHANGES IN THE WORK

9.1 General

9.1.1 The County may, at any time, without invalidating this Contract and without notice to sureties, direct changes in the Work within the general scope of this Contract, consisting of additions, deletions, revisions, or any combination thereof, by Change Order or by field order. Contractor agrees to promptly comply with such orders and proceed with the Work, which shall be performed under the applicable requirements of the Contract Documents. Contract Time and Contract Price will be adjusted, in accordance with Sections 9.2 and 9.3 below, by written Change Order for changes which materially increase or decrease the cost of or time for performance of the Work.

9.1.2 If at any time Contractor believes that acts or omissions of the County constitute a change to the Work, Contractor shall submit a written notice to the Project Manager explaining in detail the basis for the change request. Contractor's written notice must be furnished within five (5) days of the commencement of the event giving rise to the claim or Contractor's knowledge of the claim, and the notice shall state the general nature and cause of the claim. Thereafter, within twenty (20) days after the termination of the event giving rise to the claim or Contractor's knowledge of the claim, Contractor shall submit written notice of the extent of the claim with supporting information and documentation to the Project Manager and County. **IT IS EXPRESSLY AND SPECIFICALLY AGREED THAT ANY AND ALL CLAIMS FOR CHANGES TO THE CONTRACT TIME OR CONTRACT PRICE SHALL BE WAIVED IF NOT SUBMITTED IN STRICT ACCORDANCE WITH THE REQUIREMENTS OF THIS SECTION.** Pending final resolution of any such claim request, Contractor shall diligently proceed with performance of this Contract regardless of any dispute concerning performance of the Work or the amount Contractor is to be paid for such Work.

9.2 Changes in the Contract Time

9.2.1 The Contract Time will be extended by Change Order in an amount equal to time lost on critical Work items due to delays beyond the control of and through no fault or negligence of Contractor if a claim for an extension is submitted in accordance with Section 8.1.2 above.

9.2.2 If Contractor is delayed in progressing any task which at the time of the delay is then critical or which during the delay becomes critical, as a direct result of unusually adverse weather conditions not reasonably anticipated, or any other causes beyond Contractor's reasonable control and not attributable to Contractor or Contractor's Subcontractor's actions or failure to act, then the date for achieving Substantial Completion of the Work may be extended for such reasonable time as the Project Manager may determine. An extension of Contract Time shall be Contractor's sole and exclusive remedy for delay unless the delay is solely caused by fraud, bad faith or active interference on the part of the County or its representatives. In no event shall Contractor be compensated for interim delays that do not extend the Contract Time.

9.2.3 Extensions to the Contract Time for delays caused by the effects of inclement weather shall be submitted as a request for a change in the Contract Time pursuant to paragraph 8.1.2 above. Time extensions are justified only when rain, other inclement weather conditions, or related adverse soil conditions result in Contractor's inability to work at least fifty percent (50%) of the normal workday on controlling items of Work identified on the accepted schedule or updates to that schedule.

9.2.4 Contractor shall, at no cost to the County, take all precautions necessary to secure the Project Jobsite from any damage that may be caused by all threatened storm events, regardless of whether the County has given notice of same. Compliance with any specific storm event precautions will not constitute additional work. Suspension of the Work caused by a threatened or actual storm event, regardless of whether the County has directed such suspension, will entitle Contractor to additional Contract Time only and shall not give rise to a claim for a change in the Contract Price.

9.3 Changes in the Contract Price

9.3.1 In connection with any claim by Contractor against the County for compensation in excess of the Contract Price, any liability of the County for Contractor's costs shall be strictly limited to direct costs incurred by Contractor and shall in no event include indirect costs or consequential damages of Contractor.

9.3.2 Any change in the Contract Price resulting from a Change Order shall be determined as follows:

- a) By mutual acceptance of a lump sum increase or decrease in costs. Upon the Project Manager's request, Contractor shall furnish a detailed estimate of increased or decreased costs, together with cost breakdowns and other support data as the Project Manager may reasonably request.
- b) By Unit Prices stated in the Contract Documents, or subsequently agreed upon payment.
- c) By a manner or method mutually agreed by the County and Contractor.

9.3.3 If no mutual agreement occurs between the County and Contractor, then the change in the Contract Price, if any, shall than be determined by the Project Manager on the basis of the reasonable expenditures or savings of those performing, deleting or revising the Work attributable to the change, including, in the case of an increase or decrease in the Contract Price, a reasonable allowance for direct job site overhead and profit. In such case, Contractor shall present, in such form and with such content as the County or the Project Manager requires, an itemized accounting of such expenditures or savings shall be limited to the following: reasonable costs of materials, supplies, or equipment including delivery costs, reasonable costs of labor, including social security, unemployment insurance, fringe benefits required by a pre-existing Contract or by custom, and workers' compensation insurance, reasonable costs of premiums for all bonds and insurance, permit fees, and sales, use or other taxes paid by Contractor that are directly attributable to the changed Work. In no event shall any expenditure or savings associated with Contractor's home office or other non-Jobsite overhead expenses be included in any change in the Contract Price. Pending final determination of reasonable expenditures or savings to the County, payments shall be made to Contractor based on the Project Manager's recommendation for payment.

9.3.4 Costs which will not be allowed or paid in Change Orders or other claims under this Contract include, but are not limited to, the costs of preparing or reviewing change request/claims or proposed Change Orders, change request/claim consulting costs; lost revenues; lost profits; lost income or earnings; interest cost of any type other than those mandated by statute; rescheduling costs; lost earnings; loss of other business; or the costs of Contractor representatives visiting the Jobsite or participating in meetings with the County. The County shall not be liable to Contractor for claims of third parties,

including Subcontractors, unless and until liability of Contractor has been established therefore in a court of competent jurisdiction.

9.4 Acceptance of Change Orders

Contractor's written acceptance of a Change Order shall constitute a final and binding Contract to the provisions thereof and a waiver of all claims in connection therewith, whether direct, indirect, or consequential in nature.

9.5 Notice to Sureties

Contractor shall notify and obtain the timely consent and approval of Contractor's surety with reference to all Change Orders if such notice, consent or approval is required by Contractor's surety or by law. Contractor represents and warrants to County that Contractor is solely liable and responsible to so notify and obtain any such consent or approval.

9.6 Differing Site Conditions

If during the course of the Work, Contractor encounters (1) subsurface or concealed conditions at the Project's Jobsite that differ materially from those shown in the Contract Documents and from those ordinarily encountered and generally recognized as inherent in work of the character called for in this Contract; or (2) unknown physical conditions of the Project's Jobsite, of an unusual nature, which differ materially from that ordinarily encountered and generally recognized as inherent in work of the character called for in this Contract, then Contractor, without disturbing the conditions and before performing any Work affected by such conditions, shall, within twenty-four (24) hours of their discovery, notify the Project Manager in writing of the existence of the aforesaid conditions. The Project Manager shall, within two (2) business days after receipt of Contractor's written notice, investigate the site conditions identified by Contractor. If, in the sole opinion of the Project Manager, the conditions do materially so differ and cause an increase or decrease in Contractor's cost of, or the time required for, the performance of any part of the Work, whether or not charged as a result of the conditions, the Project Manager may recommend an equitable adjustment to the Contract Price, or the Contract Time, or both. If Project Manager and Contractor cannot agree on an adjustment in the Contract Price or Contract Time, the adjustment shall be referred to the Assistant Director of Purchasing and Contracts for determination in accordance with the provisions of Paragraph 1.5. No request by Contractor for an equitable adjustment to this Contract under this provision shall be allowed unless Contractor has given written notice to the Project Manager in strict accordance with the provisions of this Article. **No request for an equitable adjustment or change to the Contract Price or Contract Time for differing site conditions shall be allowed if made after the date certified by the Project Manager as the date of Substantial Completion.**

The failure by Contractor to provide written notice as provided in this Paragraph 9.6 shall constitute a waiver by Contractor of any Claim arising out of or relating to such concealed or unknown condition.

ARTICLE X UNCOVERING WORK, STOPPING WORK, AND ACCEPTING DEFECTIVE OR NONCONFORMING WORK

10.1 Uncovering Work

10.1.1 No Work or portion of Work shall be covered until inspected by the County as required by the Contract Documents. If any of the Work is covered contrary to the request or direction of the County or the Project Manager or contrary to the requirements of the Contract Documents, Contractor shall, upon written request, uncover it for the Project Manager's inspection and subsequently cover the Work in accordance with the Contract Documents without adjustment to the Contract Time or Contract Price. The provisions and obligations set forth herein shall apply even if the County ultimately determines (after uncovering and inspection) that the underlying Work in question conforms to the requirements of the Contract Documents.

10.1.2 Should the County wish to either (i) re-inspect a portion of the Work that has been covered by Contractor in compliance with Paragraph 9.1.1, above, or (ii) inspect a portion of the Work that has been covered by Contractor which is not required by the Contract Documents to be observed or inspected prior to its being covered and which the County did not specifically request to observe prior to its being covered, Contractor shall uncover the applicable portion of the Work upon written request. If the County determines that the Work uncovered conforms to the requirements of the Contract Documents, then the County will pay the costs of uncovering and replacement of the cover through a Change Order and will adjust the Contract Time by Change Order if the uncovering and replacement Work extends the most current Substantial Completion or Final Completion date, as applicable. If, however, the County determines that the Work uncovered does not conform to the requirements of the Contract Documents, then Contractor shall pay the costs of uncovering and replacement and shall not be entitled to an adjustment of the Contract Price.

10.2 Right to Stop Work

If the Work is defective, or Contractor fails to supply sufficient skilled workers, suitable materials, or equipment or fails to furnish or perform the Work in such a way that the completed Work will conform to the Contract Documents, the County, acting through the Project Manager, may order Contractor to stop the Work, or any portion thereof, until the cause for such order has been eliminated. The County's right to stop Work, or any portion thereof, shall not give rise to any duty on the part of the County to exercise this right for the benefit of Contractor or any other party.

10.3 County May Accept Defective or Nonconforming Work

If the County chooses to accept defective or nonconforming Work, the County may do so. In such events, the Contract Price shall be reduced by the greater of (a) the reasonable cost of removing and correcting the defective or nonconforming Work, and (b) the difference between the fair market value of the Work had it not been constructed in such manner as to include defective or nonconforming Work. If the remaining portion of the unpaid Contract Price, if any, is insufficient to compensate the County for its acceptance of defective or nonconforming Work, Contractor shall, pay the County such remaining compensation for accepting defective or nonconforming Work.

ARTICLE XI CONTRACT SUSPENSION AND TERMINATION

11.1 Suspension

The County may, by written notice, order Contractor to suspend, delay or interrupt Work, in whole or in part, for a period of time as the County may determine. If such suspension delays Contractor's ability to meet the authorized Contract Time, Contractor will be granted an extension of time as reasonably agreed by both parties. Contractor shall not be entitled to an adjustment to the Contract Time to the extent that performance is, was or would have been so suspended, delayed or interrupted by another cause, act or omission for which Contractor is responsible. Notwithstanding anything to the contrary in this Contract and, in the event any such suspension exceeds ninety (90) days, Contractor may, upon ten (10) days written notice to the County, terminate performance under this Contract and recover from the County an equitable adjustment in accordance with Section 9.3 above.

11.2 Termination

11.2.1 The County may by written notice to Contractor terminate the Work under this Contract in whole or in part at any time for the County's convenience or for the default of Contractor.

11.2.2 The County may terminate this Contract, in whole or in part, for its convenience upon thirty (30) calendar days written notice to the Contractor. If the termination is for the convenience of the County, an equitable adjustment in the compensation to be paid to the Contractor may be made based upon the cost for completed Work, Work in progress, and the substantiated, reasonable and actually incurred costs associated with termination, including demobilization costs and amounts due in settlement of terminated contracts with Subcontractors. No amount shall be allowed for anticipated profit or unperformed work.

11.2.3 Contractor may terminate this Contract, for any reason up to sixty (60) calendar days written notice, provided that any outstanding Work is completed by Contractor, or Contractor's Subcontractors. Contractor further agrees to cooperate fully and assist the County, upon request, in order to complete any Work under this Project. In such event, the County shall compensate the Contractor as mutually agreed in writing for any such Work after termination.

11.2.4 The County may terminate this Contract, in whole or in part, for cause (or "default"). In the event of Contractor's default, the County shall issue a Notice of Default to the Contractor, articulating the items which the County finds to be in default of the requirements of this Agreement. Contractor shall have ten (10) calendar days from receipt of the Notice of Default to remedy deficiencies or submit, in writing, an acceptable plan for remedying the deficiencies identified in said notice. If Contractor fails to remedy such deficiencies, or to submit an acceptable plan for remedying such deficiencies, to the satisfaction of the County within the stated time period, the County shall issue a Notice of Termination, and take over and prosecute the Work to completion. In such case, Contractor shall be liable to the County for all reasonable additional costs incurred by the County in completion of the Work.

11.2.5 Upon receipt of such termination notice Contractor shall immediately stop all Work and shall immediately cause any and all of its Subcontractors and material suppliers at any tier, to immediately stop all work, leaving the construction Site in a safe and secured condition. Contractor shall not be paid for any work performed or costs incurred after the

termination date that reasonably could have been avoided. The County may direct Contractor to assign Contractor's right, title and interest under terminated orders or subcontracts to its designee.

11.2.6 Contractor shall not remove from the construction Jobsite any materials, equipment, plant or tools that have been paid for by County pursuant to this Contract. Contractor hereby grants the County a free and unimpeded right of access to Contractor's facilities, which shall survive any termination of the Contract, for the purpose of permitting the County to take control of and remove any Work, including but not limited to any Work for which title has vested in the County.

11.2.7 For purposes of this Termination provision, Contractor shall be deemed in default if Contractor (1) persistently or repeatedly refuses or fails to perform the Work in a timely manner, (2) fails to supply enough properly skilled Workers, supervisory personnel or proper equipment or materials, (3) fails to make prompt payment to Subcontractors, or for materials or labor, (4) becomes insolvent or becomes the subject of voluntary or involuntary bankruptcy proceedings, (5) persistently disregards laws, ordinances, rules, regulations or orders of any public authority having jurisdiction, or (6) breaches or violates a material provision of this Contract. If the termination is attributable to the default of Contractor, the County shall have the right, without prejudice to any other right or remedy, to take possession of the construction Jobsite and of all materials, equipment, tools, construction equipment and machinery thereon owned by Contractor and may finish the Work by whatever methods it may deem expedient. In such case, Contractor shall not be entitled to receive any further payment until the Work is finished.

11.2.8 If the unpaid balance of the Contract Price less any liquidated damages due under this Contract, exceeds the cost of finishing the Work, including compensation for the Project Manager's additional services and expenses made necessary thereby, Contractor shall pay the difference to the County. This obligation for payment shall survive the termination of the Contract.

11.2.9 If, after termination by the County for Contractor's default, it is determined by a Court of competent jurisdiction that Contractor was not in default, or that the delay was excusable, the rights and obligations of the parties, including adjustment of the Contract Price, will be the same as if the termination had been issued for the convenience of the County, as provided under Paragraph 11.2.4 above.

ARTICLE XII WARRANTY AND INDEMNITY

12.1 Warranty

12.1.1 Contractor warrants and guarantees to the County that all labor furnished to progress the Work under this Contract shall be competent to perform the tasks undertaken and that the product of such labor shall yield only first-class results and that all materials and equipment furnished under this Contract shall be of good quality, free from faults and defects and in strict conformance with the Contract Documents.

12.1.2 Contractor warrants all materials, equipment and labor it furnishes or performs under this Contract against all defects in design, materials and workmanship for a period of one year (or the period of time in any guarantee or warranty provided by any manufacturer or supplier of equipment or materials incorporated into the Work, whichever is later) from and after the date of Final Completion. Contractor shall within ten (10) Days after being notified in writing by the County of any defect in the Work or non-conformance of the Work (Warranty Work), commence and prosecute with due diligence all Work necessary to fulfill the terms of the warranty at its sole cost and expense. Contractor shall act sooner as requested by the County in response to an emergency. In addition, Contractor shall, at its sole cost and expense, repair and replace any portions of the Work (or work of other contractors) damaged by its Warranty Work or which becomes damaged in the course of repairing or replacing Warranty Work. For any Work so corrected, Contractor's obligation hereunder to correct Warranty Work shall be reinstated for an additional one-year period, commencing with the date of acceptance of such corrected Work.

12.1.3 Contractor shall perform such tests as the County may require to verify that any corrective actions, including, without limitation, redesign, repairs, and replacements comply with the requirements of the Contract Documents. All costs associated with such corrective actions and testing, including the removal, replacement, and reinstatement of equipment and materials necessary to gain access, shall be the sole responsibility of Contractor.

12.1.4 All warranties and guarantees of subcontractors, suppliers and manufacturers with respect to any portion of the Work, whether express or implied, are deemed to be obtained by Contractor for the benefit of the County, regardless of

whether or not such warranties and guarantees have been transferred or assigned to the County by separate Contract and Contractor agrees to enforce such warranties and guarantees, if necessary, on behalf of the County.

12.1.5 In the event that Contractor fails to perform its obligations under this Warranty Section, or under any other warranty or guaranty under this Contract, to the reasonable satisfaction of the County, the County shall have the right to correct and replace any defective or non-conforming Work and any work damaged by such work or the replacement or correction thereof at Contractor's sole expense. Contractor shall be obligated to fully reimburse the County for any expenses incurred hereunder upon demand.

12.1.6 Failure on the part of the County to reject defective, non-conforming or unauthorized Work shall not release Contractor from its contractual obligations, be construed to mean acceptance of such Work or material by the County, or, after Final Completion, bar the County from recovering damages or obtaining such other remedies as may be permitted by law.

12.1.7 No adjustment in the Contract Time or Contract Price will be allowed because of delays in the performance of the Work as a result of correcting defective, non-conforming or unauthorized Work.

12.1.8 County and Contractor agree that the provisions of Florida Statute Chapter 558 shall not apply to this Contract.

12.2 Indemnity

12.2.1 Contractor shall indemnify and hold harmless the County and its officers and employees ("Indemnified Party"), from liabilities, damages, losses and costs, including, but not limited to, reasonable attorney's fees, to the extent caused by the negligence, recklessness, or intentional wrongful misconduct of Contractor and persons employed or utilized by Contractor in the performance of this Contract.

12.2.2 To the extent permitted by, and in accordance with Section 725.06 of the Florida Statutes, Contractor further agrees that "damages, losses and costs", includes fines, citations, court judgments, insurance claims, restoration costs or other liability, to the extent caused by the negligence, recklessness, or intentional wrongful misconduct of Contractor and persons employed or utilized by Contractor in the performance of this Contract.

12.2.3 To the extent permitted by, and in accordance with Section 725.06 of the Florida Statutes, for purposes of indemnity, the "persons employed or utilized by Contractor" shall be construed to include, but not be limited to, Contractor, its staff, employees, subcontractors, all deliverers, suppliers, furnishers of materials or services or anyone acting for, on behalf of, or at the request of Contractor.

12.2.4 In Claims against any person or entity indemnified hereunder by an employee of Contractor, any Subcontractor, or subcontractor, anyone directly or indirectly employed by them or anyone for whose acts they may be liable, the indemnification obligation under this Section 11.2 shall not be limited by a limitation on the amount or type of damages, compensation or benefits payable by or for Contractor or any Subcontractor or subcontractor under any workers' compensation acts, disability benefits acts or other employee benefit acts.

12.2.5 Contractor's indemnity and hold harmless obligations hereunder shall extend to all Claims against the County by any third party or third-party beneficiary of this Contract and all liabilities, damages, losses and costs related thereto.

12.2.6 This indemnification will not be valid in the instance where the loss is caused by the gross negligence, or willful, wanton or intentional misconduct of any Indemnified Party.

12.2.7 If any provision(s), or portion(s) of a provision(s) of this Section, or the application thereof to any person or circumstance shall, to any extent, be held to be invalid, illegal or unenforceable for any reason whatsoever, the validity, legality and enforceability of the remaining provision(s), or part of the provision(s), shall not in any way be affected or impaired thereby; and shall be interpreted to the fullest extent possible to be enforceable and to give effect to the intent manifested by the provision(s), or portion(s) thereof, held invalid, illegal or unenforceable.

12.2.8 Contractor shall further indemnify and hold harmless the County its officers and employees from and against all Claims arising out of any infringement of patent rights or copyrights incident to the use in the performance of the Work or

resulting from the incorporation in the Work of any invention, design, process, product, or device not specified in the Contract Documents and shall defend such Claims in connection with any alleged infringement of such rights.

12.2.9 The indemnification provisions of this Section 11.2 shall survive expiration or earlier termination of this Contract.

ARTICLE XIII INSURANCE AND BONDS

13.1 Contractor's Insurance Requirements

13.1.1 All insurance policies shall be satisfactory to the County and be issued by companies authorized and duly licensed to transact business in the State of Florida. Contractor shall furnish proof of insurance to the County prior to execution of this Contract. No Work shall commence under this Contract until Contractor has obtained all insurance coverages required under this section. Certificates of insurance shall clearly indicate Contractor has obtained insurance of the type, amount, and classification as required by this Contract. Required insurance coverage shall be maintained in force, including coverage for Additional Insureds, until Final Completion of all Work including Warranty Work.

13.1.2 No less than ten (10) days written notice shall be provided to the County prior to cancellation, non-renewal or any material change of required insurance policies. Yearly renewal certificates shall be provided to the County within thirty (30) days of expiration of the current policy.

13.1.3 The types and amounts of insurance required under this Contract do not in any way limit the liability of Contractor including under any warranty or indemnity provision of this Contract or any other obligation whatsoever Contractor may have to the County or others. Nothing in this Contract limits Contractor to the minimum required insurance coverages found in this Article XIII.

13.2 Additional Insured Endorsements and Certificate Holder

The term "Additional Insured", as used in this Contract, shall mean St. John's County, its elected officials, officers, employees, agents and representatives. Certificates of insurance shall specifically name each Additional Insured for all policies of insurance except Workers' Compensation and Professional Liability. A copy of the endorsement showing the required coverages must accompany the certificate of insurance.

Certificate Holder Address: St. Johns County, a political subdivision of the State of Florida
500 San Sebastian View
St. Augustine, FL 32084
Attn: Purchasing Division

13.3 Workers Compensation

Contractor shall procure and maintain during the life of this Contract, adequate Workers' Compensation Insurance in at least such amounts as is required by law for all of its employees per Florida Statute 440.02.

13.4 Commercial General Liability

Contractor shall procure and maintain during the life of this Contract, Comprehensive General Liability Insurance with minimum limits of \$1,000,000 per occurrence, \$2,000,000 aggregate, including bodily injury (including wrongful death), property damage, products, personal & advertising injury, and completed operations. This insurance must provide coverage for all Claims that may arise from the services and/or operations completed under this Contract, whether such services or operations are by Contractor or anyone directly or indirectly employed by them. Such insurance(s) shall also be primary and non-contributory with regard to insurance carried by the Additional Insureds.

13.5 Automobile Liability

Contractor shall procure and maintain during the life of this Contract, Comprehensive Automobile Liability Insurance with minimum limits of \$2,000,000 combined single limit for bodily injury and property damage liability and insuring liability arising out of or in any way related directly or indirectly to the ownership, maintenance or use of any owned, non-owned or rented/hired automobiles.

13.6 Additional Coverages

ONLY THE SUBSECTIONS CORRESPONDING TO ANY CHECKED BOX IN THIS PARAGRAPH 12.6 WILL APPLY TO THIS CONTRACT.

13.6.1 Professional Liability.

13.6.1.1 Contractor shall procure and maintain, during the life of this Contract, Professional Liability or Errors and Omissions Insurance with minimum limits of \$1,000,000 with 10-year tail coverage starting upon Final Completion. Contractor's professional liability policy should not have an exclusion for environmental compliance management or construction management professionals.

13.6.1.2 In the event that Contractor employs professional engineering or land surveyor services for performing field engineering or preparing design calculations, plans, and specifications, Contractor shall require the retained engineers and land surveyors to carry professional liability insurance with limits not less than \$1,000,000 each claim with respect to negligent acts, errors, or omissions in connection with professional services to be provided under this Contract.

13.6.2 Builders Risk.

a. Contractor shall procure and maintain Builder's Risk ("all risk") insurance on a replacement cost basis. The amount of coverage shall be equal to the full replacement cost on a completed value basis, including periodic increases or decreases in values through change orders.

13.6.2.2 The Builder's Risk policy shall identify the County as the sole loss payee. The policy shall name as insured the County, Contractor and its subcontractors of every tier. Each insured shall waive all rights of subrogation against each of the other insured to the extent that the loss is covered by the Builder's Risk Insurance. The Builder's Risk policy shall be primary and any self-insurance maintained by the County in not contributory. The Builder's Risk policy shall not include a co-insurance clause. This coverage shall not be lapsed or cancelled because of partial occupancy by the County prior to Final Completion of the Work.

13.6.2.3 The Builder's Risk insurance shall:

- a. insure against at least the following perils or causes of loss: fire; lightning; windstorm; riot; civil commotion; terrorism; vehicle impact; aircraft; smoke; theft; vandalism and malicious mischief; mechanical breakdown, boiler explosion, and artificially generated electric current; earthquake; volcanic activity, and other earth movement; flood; collapse; explosion; debris removal including demolition as may be reasonably necessary; and water damage (other than that caused by flood).
- b. cover, as insured property, at least the following: (i) the Work and all appurtenances, materials, supplies, fixtures, machinery, apparatus, equipment and other property of a similar nature that are to be incorporated into or used in the preparation, fabrication, construction, erection, or completion of the Work including County furnished or assigned property; (ii) spare parts inventory required within the scope of the Contract; and (iii) temporary works which are not intended to form part of the permanent constructed Work but which are intended to provide working access to the Jobsite, or to the Work under construction, or which are intended to provide temporary support for the Work under construction, including scaffolding, form work, fences, shoring, falsework, and temporary structures.
- c. extend to cover damage or loss to insured property (i) while in transit; and (ii) while in temporary storage at the Jobsite or in a storage location outside the Jobsite (but not including property stored at the premises of a manufacturer or supplier).
- d. include (i) performance/start-up and hot testing; (ii) soft costs (e.g. design and engineering fees, code updates, permits, bonds, insurances, and inspection costs); and (iii) costs of funding or financing when a covered risk causes delay in completing the Work.

13.6.3 The Builder's Risk Insurance may have a deductible clause. Contractor shall be responsible for paying any and all deductible costs. Notwithstanding anything to the contrary set forth above, the deductible for coverage of all perils and causes of loss enumerated in subparagraph 12.6.2.3 above shall not exceed \$250,000.

13.7 Other Requirements

The required insurance limits identified in Sections 12.4, 12.5, and 12.6 above may be satisfied by a combination of a

primary policy and/or Umbrella or Excess Liability Insurance policy. Contractor shall require each lower-tier subcontractor to comply with all insurance requirements appropriate for its scope of work, and any deficiency shall not relieve Contractor of its responsibility herein. Upon written request, Contractor shall provide County with copies of lower-tier subcontractor certificates of insurance.

Providing and maintaining adequate insurance coverage is a material obligation of Contractor. County has no obligation or duty to advise Contractor of any non-compliance with the insurance requirements contained in this Section. If Contractor fails to obtain and maintain all of the insurance coverages required herein, Contractor shall indemnify and hold harmless the Additional Insureds from and against any and all Claims that would have been covered by such insurance had Contractor complied with its obligations herein.

County reserves the right to adjust the above minimum insurance requirements or require additional insurance coverages to address other insurable hazards.

13.8 Payment and Performance Bonds

Contractor shall execute, furnish the County with, and record in the public records of St. John's County, a Payment and Performance Bond in accordance with the provisions of Sections 255.05 and 287.0935 Florida Statutes, in an amount no less than the Contract Price. Such Payment and Performance Bond shall be conditioned upon the successful completion of all work, labor, services, equipment and materials to be provided and furnished hereunder, and the payment of all subcontractors, materialmen, and laborers. Said bond shall be subject to the approval of the Board of County Commissioners of St. John's County, Florida. In accordance with Section 255.05, F.S., the County may not make a payment to Contractor until Contractor has provided the County a certified copy of the recorded bond.

ARTICLE XIV MISCELLANEOUS

14.1 Independent Contractor

Contractor represents that it is fully experienced and properly qualified, licensed, equipped, organized, and financed to perform the Work under this Contract. Contractor shall act as an independent contractor and not as an agent in performing this Contract and shall maintain complete control over its employees and all of its Subcontractors and suppliers of any tier. Nothing contained in this Contract or any lower-tier subcontract or purchase order awarded by Contractor shall create any contractual relationship between any such subcontractor or supplier and the County. Contractor shall perform all Work in accordance with the requirements of this Contract and in accordance with its own methods subject to compliance with this Contract.

14.2 Examination of Contractor's Records

The County or its authorized representative shall, until the expiration of five (5) years after final payment under this Contract, have access to, and the right to examine any directly pertinent books, documents, papers and records of Contractor involving transactions relating to this Contract, and to make copies, excerpts and transcriptions thereof. If any such examination reveals that Contractor has overstated any component of the Contract Price, Change Order, Claim, or any other County payment obligation arising out of this Contract, then Contractor shall, at the election of the County, either immediately reimburse to the County or offset against payments otherwise due Contractor, the overstated amount plus interest. The foregoing remedy shall be in addition to any other rights or remedies the County may have.

14.3 Backcharges

Upon the County's notification to undertake or complete unperformed Work such as cleanup or to correct defective or non-conforming services, equipment, or material (Backcharge Work), if Contractor states or by its actions indicates it is unable or is unwilling to immediately proceed and/or complete the Backcharge Work in an agreed time; the County may perform such Backcharge Work by the most expeditious means available and backcharge Contractor for any and all costs thereby incurred by the County.

The County shall separately invoice or deduct and retain from payments otherwise due to Contractor the costs for Backcharge Work. The County's right to backcharge is in addition to any and all other rights and remedies provided in this Contract or by law. The County's performance of the Backcharge Work shall not relieve Contractor of any of its responsibilities under this Contract and Contractor shall be responsible for the Backcharge Work as if it were its own.

14.4 Applicable Law

Contractor and the Work must comply with all Applicable Law and the requirements of any applicable grant agreements.

14.5 Governing Law & Venue

The Contract shall be governed by the laws of the State of Florida. Venue for any administrative and/or legal action arising under the Contract shall be St. Johns County, Florida.

14.6 Assignment

Contractor shall not sell, assign or transfer any of its rights, duties or obligations under the Contract, or under any Change Order issued pursuant to the Contract or make an assignment or transfer of any amounts payable to Contractor under the Contract, without the prior written consent of the County. In the event of any assignment, Contractor remains secondarily liable for performance of the Contract, unless the County expressly waives such secondary liability. The County may assign the Contract with prior written notice to Contractor of its intent to do so. This Contract may be assumed by and shall inure to the benefit of the County's successors and assigns without the consent of Contractor.

14.7 Severability

If a court deems any provision of the Contract void, invalid or unenforceable, that provision shall be enforced only to the extent that it is not in violation of law or is not otherwise unenforceable and all other provisions shall remain in full force and effect.

14.8 Section Headings

The section and other headings contained in this Contract are for reference purposes only and shall not affect the meaning or interpretation of this Contract.

14.9 Disclaimer of Third-Party Beneficiaries

This Contract is solely for the benefit of County and Contractor and no right or cause of action shall accrue to or for the benefit of any third party not a formal party hereto. Nothing in this Contract, expressed or implied, is intended or shall be construed to confer upon or give any person or entity other than County and Contractor, any right, remedy, or Claim under or by reason of this Contract or any provisions or conditions hereof; and all of the provisions, representations, covenants and conditions herein contained shall inure to the sole benefit of and shall be binding upon County and Contractor.

14.10 Waiver; Course of Dealing

The delay or failure by the County to exercise or enforce any of its rights or remedies under this Contract shall not constitute or be deemed a waiver of the County's right thereafter to enforce those rights or remedies, nor shall any single or partial exercise of any such right or remedy preclude any other or further exercise thereof or the exercise of any other right or remedy. The conduct of the parties to this Contract after the Effective Date shall not be deemed a waiver or modification of this Contract.

14.11 No Waiver of Sovereign Immunity

Nothing herein is intended to serve as a waiver of sovereign immunity by any agency or political subdivision to which sovereign immunity may be applicable or of any rights or limits to liability existing under Section 768.28, Florida Statutes. This section shall survive the termination of all performance and obligations under this Contract and shall be fully binding until such time as any proceeding brought on account of this Contract is barred by any applicable statute of limitations.

14.12 Execution in Counterparts

This Contract may be executed in counterparts, each of which shall be an original document, and all of which together shall constitute a single instrument. The parties may deliver executed counterparts by e-mail transmission, which shall be binding. In the event this Contract is executed through a County-approved electronic signature or online digital signature service (such as DocuSign), such execution shall be valid, effective and binding upon the party so executing. Execution and delivery of an executed counterpart of this Contract and/or a signature page of this Contract by electronic image scan transmission (such as a "pdf" file) or through a County approved electronic signature service will be valid and effective as delivery of a manually executed counterpart of this Contract.

14.13 Entire Contract

This Contract for the Work, comprised of the Contract Documents enumerated herein, constitutes the entire Contract between the Parties relating to the subject matter hereof and supersedes all prior or contemporaneous Contracts, negotiations, discussions and understandings, oral or written. This Contract may not be amended or modified except in writing, as provided

herein and signed by authorized representatives of both parties.

14.14 Survival

The provisions of the Contract Documents which by their nature survive termination of the Contract, including without limitation all warranties, indemnities, insurance, payment obligations, and the County's right to audit Contractor's books and records, shall in all cases survive the expiration or earlier termination of this Contract.

14.15 Employment Eligibility and Mandatory Use of E-Verify

As a condition precedent to entering into this Contract, and in accordance with section 448.095, F.S., Contractor and its subcontractors shall register with and use the E-Verify system to verify the work authorization status of all employees hired on or after January 1, 2021.

- a. Contractor shall require each of its subcontractors to provide Contractor with an affidavit stating that the subcontractor does not employ, contract with, or subcontract with an unauthorized alien. Contractor shall maintain a copy of such affidavit for the duration of this Contract.
- b. The County, Contractor, or any subcontractor who has a good faith belief that a person or entity with which it is contracting has knowingly violated section 448.09(1), F.S. or these provisions regarding employment eligibility shall terminate the contract with the person or entity.
- c. The County, upon good faith belief that a subcontractor knowingly violated these provisions regarding employment eligibility, but Contractor otherwise complied, shall promptly notify Contractor and Contractor shall immediately terminate the contract with the subcontractor.
- d. The County and Contractor hereby acknowledge and mutually agree that, a contract terminated pursuant to these provisions regarding employment eligibility is not a breach of contract and may not be considered as such. Any contract terminated pursuant to these provisions regarding employment eligibility may be challenged in accordance with section 448.095(2)(d), F.S.
- e. Contractor acknowledges that, in the event that the County terminates this Contract for Contractor's breach of these provisions regarding employment eligibility, then Contractor may not be awarded a public contract for at least one (1) year after such termination. Contractor further acknowledges that Contractor is liable for any additional costs incurred by the County as a result of the County's termination of this Contract for breach of these provisions regarding employment eligibility.
- f. Contractor shall incorporate in all subcontracts made pursuant to this Contract the provisions contained herein regarding employment eligibility.

14.16 Equal Employment Opportunity

During the performance of this Contract, Contractor agrees as follows:

14.16.1 Contractor will not discriminate against any employee or applicant for employment because of race, color, religion, disability, age, sex (including sexual orientation and gender identity/expression), national origin (including limited English proficiency), marital status, or familial status. Contractor will take affirmative action to ensure that applicants and employees are treated during employment without regard to their race, color, religion, disability, sex, age, national origin, ancestry, marital status, sexual orientation, gender identity or expression, familial status, genetic information or political affiliation. Such action shall include, but not be limited to, the following: employment, upgrading, demotion or transfer, recruitment or recruitment advertisement, layoff or termination, rates of pay or other forms of compensation, and selection for training, including apprenticeship. Contractor agrees to post in conspicuous places, available to employees and applicants for employment, notices setting forth the provisions of this non-discrimination clause.

14.16.2 Contractor will, in all solicitations or advertisements for employees placed for, by, or on behalf of Contractor, state that all qualified applicants will receive consideration for employment without regard to race, color, religion, disability, sex, age, national origin, ancestry, marital status, sexual orientation, gender identity or expression, familial status, or genetic information.

Contractor will not discharge or in any other manner discriminate against any employee or applicant for employment because such employee or applicant has inquired about, discussed, or disclosed the compensation of the employee or applicant or another employee or applicant. This provision shall not apply to instances in which an employee who has access to the compensation information of other employees or applicants as a part of such employee's essential job functions discloses the compensation of such other employees or applicants to individuals who do not otherwise have access to such information, unless such disclosure is in response to a formal complaint or charge, in furtherance of an investigation, proceeding, hearing, or action, including an investigation conducted by the employer, or is consistent with Contractor's legal duty to furnish information.

Contractor will send to each labor union or representatives of workers with which it has a collective bargaining Contract or other contract or understanding, a notice to be provided by the County, advising the labor union or workers' representative of Contractor's commitments under Section 202 of Executive Order 11246 of September 24, 1965, and shall post copies of the notice in conspicuous places available to employees and applicants for employment.

Contractor will comply with all provisions of Executive Order 11246 of September 24, 1965, and of the rules, regulations, and relevant orders of the Secretary of Labor.

Contractor will furnish all information and reports required by Executive Order 11246 of September 24, 1965, and by the rules, regulations, and orders of the Secretary of Labor, or pursuant thereto, and will permit access to its books, records, and accounts by the County and the Secretary of Labor for purposes of investigation to ascertain compliance with such rules, regulations, and orders.

In the event of Contractor's noncompliance with the nondiscrimination clauses of this Contract or with any of such rules, regulations, or orders, this Contract may be cancelled, terminated or suspended in whole or in part and Contractor may be declared ineligible for further contracts in accordance with procedures authorized in Executive Order 11246 of September 24, 1965, and such other sanctions may be imposed and remedies invoked as provided in Executive Order 11246 of September 24, 1965, or by rule, regulation, or order of the Secretary of Labor, or as otherwise provided by law.

14.16.8 Contractor will include the provisions of paragraphs 14.16.1 through 14.16.8 in every subcontract or purchase order unless exempted by rules, regulations, or orders of the Secretary of Labor issued pursuant to Section 204 of Executive Order 11246 of September 24, 1965, so that such provisions will be binding upon each subcontractor or vendor. Contractor will take such action with respect to any subcontractor or vendor as may be directed to the Secretary of Labor as a means of enforcing such provisions including sanctions for noncompliance: Provided, however, that in the event Contractor becomes involved in, or is threatened with, litigation with a subcontractor or vendor as a result of such direction, Contractor may request the United States to enter into such litigation to protect the interest of the United States.

14.17 Public Records

14.17.1 Contractor shall comply and shall require all of its Subcontractors to comply with the State of Florida's Public Records Statute (Chapter 119), specifically to:

- (1) Keep and maintain public records that ordinarily and necessarily would be required by the County in order to perform the Services;
- (2) Upon request from the County's custodian of public records, provide the County with a copy of the requested records or allow the records to be inspected or copied within a reasonable time at a cost that does not exceed the cost as provided in Chapter 119, Florida Statutes, or as otherwise provided by Applicable Law;
- (3) Ensure that public records related to this Contract that are exempt or confidential and exempt from public records disclosure requirements are not disclosed except as authorized by Applicable Law for the duration of this Contract and following expiration of this Contract, or earlier termination thereof, if Contractor does not transfer the records to the County; and
- (4) Upon completion of this Contract, or earlier termination thereof, transfer, at no cost, to the County all public records in possession of Contractor or keep and maintain for inspection and copying all public records required by the County to perform the Work.

14.17.2 If Contractor, upon expiration of this Contract or earlier termination thereof i) transfers all public records to the County, Contractor shall destroy any duplicate public records that are exempt or confidential and exempt from public records disclosure requirements; and ii) keeps and maintains public records, Contractor shall meet all Applicable Law and requirements for retaining public records. All records stored electronically must be provided to the County, upon request from the County's custodian of public records, in a format that is compatible with the County's information technology systems.

14.17.3 Failure by Contractor to comply with the requirements of this section shall be grounds for immediate, unilateral termination of this Contract by the County.

IF CONTRACTOR HAS QUESTIONS REGARDING THE APPLICATION OF CHAPTER 119, FLORIDA STATUTES, TO ITS DUTY TO PROVIDE PUBLIC RECORDS RELATING TO THIS CONTRACT, CONTACT THE CUSTODIAN OF PUBLIC RECORDS AT: (904) 209-0805, PUBLICRECORDS@SJCFL.US, 500 SAN SEBASTIAN VIEW, ST. AUGUSTINE, FLORIDA 32084

14.18 Anti-Bribery

Contractor and its Subcontractors shall at all times during the term of this Contract comply with all anti-bribery and corruption laws that are applicable to the performance of this Contract. Contractor represents that it has not, directly or indirectly, taken any action which would cause it to be in violation of Chapter 838 of the Florida Statutes. Contractor shall immediately notify the County of any violation (or alleged violation) of this provision.

14.19 Convicted and Discriminatory Vendor Lists, and Scrutinized Companies

14.19.1 Contractor warrants that neither it nor any Subcontractor is currently on the convicted vendor list or the discriminatory vendor list maintained pursuant to Sections 287.133 and 287.134 of the Florida Statutes, or on any similar list maintained by any other state or the federal government. Contractor shall immediately notify the County in writing if its ability to perform is compromised in any manner during the term of the Contract.

14.19.2 Section 287.135 of the Florida Statutes prohibits agencies from contracting with companies for goods or services that are on the Scrutinized Companies that Boycott Israel List, or with companies that are engaged in a boycott of Israel, and from contracting with companies for goods or services of \$1,000,000 or more that are on the Scrutinized Companies with Activities in Sudan List or the Scrutinized Companies with Activities in the Iran Petroleum Energy Sector List, or are engaged in business operations in Cuba or Syria. The lists are created pursuant to §215.473 and §215.4725, F.S. By execution of this Contract, Contractor certifies that it is not listed on the Scrutinized Companies that Boycott Israel List, the Scrutinized Companies with Activities in Sudan List or the Scrutinized Companies with Activities in the Iran Petroleum Energy Sector List, and is not engaged in a boycott of Israel or engaged in business operations in Cuba or Syria, and understands that pursuant to §287.135, F.S., the submission of a false certification may subject Contractor to civil penalties, attorney's fees, and/or costs. In accordance with §287.135, F.S., the County may terminate this Contract if a false certification has been made, or the Contractor is subsequently placed on any of these lists, or engages in a boycott of Israel or is engaged in business operations in Cuba or Syria.

14.20 Written Notice

Any and all notices, requests, consents, approvals, demands, determinations, instructions, and other forms of written communication under this Contract shall be validly given when delivered as follows:

- i. Hand delivered to Contractor's Authorized Representative or hand delivered during normal business hours and addressed as shown below, or
- ii. Delivered by U.S. Mail, electronic mail or commercial express carrier, (postage prepaid, delivery receipt requested), to the following addresses:

St. Johns County
500 San Sebastian View
St. Augustine, FL 32084
Attn: Leigh A. Daniels
Email Address: ldaniels@sjcfl.us

Watson Civil Construction, Inc.
Address: 319 West Town Place, Suite 25
St. Augustine, FL 32092
Attn: Craig Peplinski
Email Address: cpeplinski@watsoncivil.com

With a copy to:

St. Johns County
Office of the County Attorney
500 San Sebastian View
St. Augustine, FL 32084
Email Address: jferguson@sjcf1.us

Notices shall be deemed to have been given on the date of delivery to the location listed above without regard to actual receipt by the named addressee. County and Contractor may each change the above addresses at any time upon prior written notice to the other party.

The authorized representatives hereto have executed this Contract effective as of the Effective Date. Contractor's authorized representative executing this Contract represents that he or she is duly authorized to execute this Contract on behalf of Contractor.

County:

St. Johns County _____ (Seal)
(Typed Name)

By: _____
(Signature of Authorized Representative)

(Printed Name)

(Title)

(Date of Execution)

Contractor:

_____ (Seal)
(Typed Name)

By: _____
(Signature of Authorized Representative)

(Printed Name)

(Title)

(Date of Execution)

ATTEST:

St. Johns County, FL
Clerk of Circuit Court & Comptroller

By: _____
(Deputy Clerk)

(Date of Execution)

Legally Sufficient:

(Office of County Attorney)

(Date of Execution)

**FORM 1
CERTIFICATION OF PAYMENTS TO SUBCONTRACTORS**

Contract No.	
Project Title:	

The undersigned Contractor hereby swears under penalty of perjury that:

1. Contractor has paid all Subcontractors all undisputed contract obligations for labor, services, or materials provided on this Project within the time period set forth in Sections 218.73 and 218.735, Florida Statutes, as applicable.

2. The following Subcontractors have not been paid because of disputed contractual obligations; a copy of the notification sent to each, explaining the good cause why payment has not been made, is attached to this form:

Subcontractor Name and Address	Date of Disputed Invoice	Amount in Dispute

Contractor's Authorized Representative executing this Certification of Payments to Subcontractors represents that he or she is duly authorized to execute this Certificate, or if executing on behalf of another, is authorized to do so and that such Authorized Representative is legally bound.

Dated _____, 20__ Contractor _____
By: _____
(Signature)
By: _____
(Name and Title)

STATE OF _____)
) SS.
COUNTY OF _____)

The foregoing instrument was acknowledged before me, by means of physical presence or online notarization, this _____ day of _____, 20__, by _____, who is personally known to me or who has produced _____ as identification and who did (did not) take an oath.

NOTARY PUBLIC:
Signature: _____
Print Name: _____

(NOTARY SEAL)
My commission expires:

FORM 2

CONTRACTOR'S FINAL RELEASE AND WAIVER OF LIEN

Owner: St. Johns County (hereafter "County")	County Department/Division:
Contract No.:	Contractor Name:
Project:	Contractor Address:
Project Address:	Contractor License No.:
Payment Amount:	Amount of Disputed Claims:

The undersigned has been paid in full for all labor, work, services, materials, equipment, and/or supplies furnished to the Project or to the County and does hereby waive and release any notice of lien, any right to mechanic's lien, any bond right, any claim for payment and any rights under any similar ordinance, rule or statute related to a claim or payment rights the undersigned has on the above described Project, except for the payment of Disputed Claims, if any, described below.

The undersigned warrants that he or she either has already paid or will use the monies received from this final payment to promptly pay in full all of its laborers, subcontractors, materialmen and suppliers for all labor, work, services, materials, equipment, or supplies provided for or to the above referenced Project.

Before any recipient of this document relies on it, the recipient should verify evidence of payment to the undersigned.

Disputed Claims: The following invoices, pay applications, retention, or extra work are reserved by undersigned from this final payment (if there are no Disputed Claims enter "None"):

None

Signed this ___ day of _____, 20__

Contractor/Company Name

By:

Signature

Printed Name

Title

NOTICE: THIS DOCUMENT WAIVES RIGHTS UNCONDITIONALLY AND STATES THAT YOU HAVE BEEN PAID FOR GIVING UP THOSE RIGHTS. THIS DOCUMENT IS ENFORCEABLE AGAINST YOU IF YOU SIGN IT TO THE EXTENT OF THE PAYMENT AMOUNT OR THE AMOUNT RECEIVED.



NOTICE OF INTENT TO AWARD

November 6, 2023

Bid No: 23-94; CR 210 WIDENING FROM TRINITY WAY TO BEACHWALK BOULEVARD

St. Johns County hereby issues this Notice of Intent to Award a contract to **Watson Civil Construction, Inc.** as the lowest, responsive, responsible Bidder under the above referenced Invitation for Bids.

Any actual Bidder, Proposer or Supplier who is aggrieved in connection with the Notice of Intent to Award a Contract, where such grievance is asserted to be the result of a violation of the requirements of the St. Johns County Purchasing Policy and associated procedures, or any applicable provision of law by the officers, agents, or employees of the County, may file a Protest to the Assistant Director of Purchasing & Contracts. The Protest must be made in writing and filed by 4:00PM on the fifth business day following the date of the posting of the Notice of Intent to Award, and must be submitted in accordance with Section 13, SJC Purchasing Policy.

Should no Protest be received in response to this Notice the County will proceed with award of a Contract in accordance with SJC Purchasing Policy.

Please forward all correspondence, requests or inquiries directly to Richard E. Poulin Jr., Procurement Coordinator, via email at rpoulin@sjcfl.us or phone at (904) 209-0160.

St. Johns County, FL
Board of County Commissioners
Purchasing Division

A handwritten signature in black ink, appearing to read "Leigh Daniels", written over a horizontal line.

Leigh Daniels, CPPB
Purchasing Manager
ldaniels@sjcfl.us
(904) 209-0154 - Direct

Date: 11/6/23



ST. JOHNS COUNTY, FL
 BID TABULATION

10/25/2023
 R.E. POWLIN RUP
 By: [Signature]
 10/26/23

OPENING DATE:
 OPENED BY:
 VERIFIED BY:
 POSTING DATE:

BID NO./TITLE: BID NO: 23-94; CR 210 WIDENING FROM TRINITY WAY TO BEACHWALK BOULEVARD

BIDDERS	TOTAL LUMP SUM BID: 18 MONTHS COMPLETION TIME	BID ALTERNATE - (ADD COST) TEMPORARY TRAFFIC CONTROL PLAN						
Besch and Smith Civil Group, Inc.	\$12,397,308.61	\$199,874.79						
J.B. Coxwell Contracting, Inc.	\$16,979,682.20	\$825,448.00						
Watson Civil Construction, Inc.	\$11,811,550.05	\$775,081.00						
Baker Constructors, Inc	\$13,750,000.00	\$3,950,000.00						

Any actual Bidder who is aggrieved in connection with the Notice of Intent to Award, where such grievance is asserted to be the result of a violation of the requirements of the County's Purchasing Policy and associated procedures, or any applicable provision of law by the officers, agents, or employees of the County, may file a Protest with the Assistant Director of Purchasing & Contracts. The Protest must be submitted in writing, accompanied by a security in the form of a Protest Bond, by 4:00PM on the fifth business day following the date of the posting of the Notice of Intent to Award.

All public records shall become available for inspection and copying pursuant to Chapter 119, Florida Statutes.

BID NO: 23-94; CR 210 Widening from Trinity Way to Beachwalk Boulevard – Revised Per Addendum #2

**OFFICIAL COUNTY BID FORM
ST. JOHNS COUNTY, FLORIDA**

TO: THE BOARD OF COUNTY COMMISSIONERS OF ST. JOHNS COUNTY, FLORIDA

DATE SUBMITTED: 10/25/2023

BID PROPOSAL OF

Watson Civil Construction, Inc.

Full Legal Company Name

319 West Town Place, Suite 25, St. Augustine, Florida 32092

Mailing Address

904-297-1800

Telephone Number

904-297-1801

Fax Number

Bidders: Having become familiar with requirements of the project, and having carefully examined the Bidding Documents and Specifications entitled for Bid No: 23-94; CR 210 Widening from Trinity Way to Beachwalk Boulevard in St. Johns County, Florida, the undersigned proposes to furnish all materials, labor and equipment, supervision and all other requirements necessary to comply with the Contract Documents to submit the following Bid Proposal summarized as follows:

Total Lump Sum Bid: 18 Months Completion Time: (As per Exhibit A – CR 210 Widening from Trinity Way to Beachwalk Boulevard Construction Plans – Dated September 2023). The Base Bid includes all work to construct the project from Trinity Way to Beachwalk Boulevard, as shown on the base bid plan sheets.

\$ 11,811,550.05

Lump Sum Bid Price (Numerical)

Eleven million, eight hundred eleven thousand, five hundred
fifty dollars and five cents

/100 Dollars

Lump Sum Bid Price (Amount written or typed in words)

Bidder shall insert the Lump Sum Bid Price above, in numerals and in words. In the event of a discrepancy between the two, the amount shall be determined by the amount written in words.

Bid Alternate – (Add Cost) Temporary Traffic Control Plan: (As per Exhibit D)

\$ 775,081.00

Lump Sum Bid Price (Written in Numerical)

Seven hundred seventy five thousand, eighty one dollars and no cents/100 Dollars

Lump Sum Bid Price (Amount written or typed in words)

BID NO: 23-94; CR 210 Widening from Trinity Way to Beachwalk Boulevard – Revised Per Addendum #2

During the preparation of the Bid, the following addenda, if any, were received:

No.: 1 Date Received: 9/28/2023 No.: 4 Date Received: 10/20/2023

No.: 2 Date Received: 10/12/2023

No.: 3 Date Received: 10/19/2023

We, the undersigned, hereby declare that no person or persons, firm or corporation, other than the undersigned are interested, in this proposal, as principals, and that this proposal is made without collusion with any person, firm or corporation, and we have carefully and to our satisfaction examined the Bid Documents and Project Specifications.

We have made a full examination of the location of the proposed work and the sources of supply of materials, and we hereby agree to furnish all necessary labor, equipment and materials, fully understanding that any quantities shown therewith are approximate only, and that we will fully complete all requirements therein as prepared by the County, within the same time limit specified in the Bid Documents as indicated above.

If the Undersigned is notified of the acceptance of this Bid Proposal by the Board within ninety (90) calendar days for the time set for the opening of Bids, the Undersigned further agrees, to execute a contract for the above work within ten (10) days after notice that his Bid has been accepted for the above stated compensation in the form of a Contract presented by the County.

The Undersigned further agrees that security in the form of a Bid Bond, certified or cashier's check in the amount of not less than **five percent (5%) of Total Lump Sum Bid Price**, payable to the County, accompanies this Bid; that the amount is not to be construed as a penalty, but as liquidated damages which said County will sustain by failure of the Undersigned to execute and deliver the Contract and Bond within ten (10) days of the written notification of the Award of the Contract to him; thereupon, the security shall become the property of the County, but if this Bid is not accepted within ninety (90) days of the time set for the submission of Bids, or if the Undersigned delivers the executed Contract upon receipt, the Security shall be returned to the Bidder within seven (7) working days.

BID NO: 23-94; CR 210 Widening from Trinity Way to Beachwalk Boulevard

CORPORATE/COMPANY

Full Legal Company Name: Watson Civil Construction, Inc. (Seal)

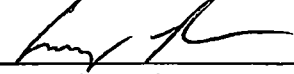
By:  Craig Peplinski, P.E., Vice President
Signature of Authorized Representative (Name & Title typed or printed)

By:  Aaron Keen, Chief Estimator
Signature of Authorized Representative (Name & Title typed or printed)

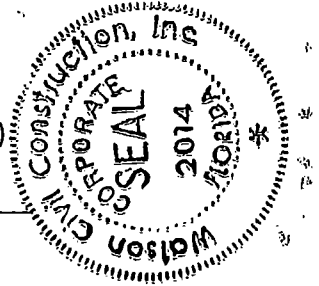

Address: 319 West Town Place, Suite, St. Augustine, Florida 32092

Telephone No.: (904) 297-1800 Fax No.: (904) 297-1801

Email Address for Authorized Company Representative: cpeplinski@watsoncivil.com

Federal I.D. Tax Number: 46-5639198 DUNS #: Not Applicable
(If applicable)

INDIVIDUAL

Name: _____ (Signature)
(Name typed or printed) (Title)

Address: _____

Telephone No.: () _____ Fax No.: _____

Email Address: _____

Federal I.D. Tax Number: _____

Each Bidder must submit all required forms and attachments. Failure to submit any required document may be grounds for disqualification due to non-responsiveness.

Submittal Requirements: Official County Bid Form, and all Attachments must be completed; along with a fully acknowledged copy of each Addendum applicable to this Bid and submitted with each copy of the Bid Proposal.

BID NO: 23-94; CR 210 Widening from Trinity Way to Beachwalk Boulevard

ATTACHMENT "A"

ST. JOHNS COUNTY AFFIDAVIT

Bidder shall complete and submit a sworn statement as part of the submitted Bid. This sworn statement shall be an Affidavit in the following form, executed by an officer/principal of the Bidder, and shall be sworn to before a person who is authorized by law to administer oaths.

STATE OF Florida

COUNTY OF Hillsborough

The Undersigned authority, Craig Peplinski, P.E. ("Affiant"), who being duly sworn, deposes and states that he/she is the Vice President (Title) of the Bidder Watson Civil Construction, Inc. (Full Legal Name of Bidder) submitting the attached Bid for the services provided in the Bid Documents for Bid No: 23-94; CR 210 Widening from Trinity Way to Beachwalk Boulevard, in St. Johns County, Florida.

The Affiant further states that no more than one Bid for the above-referenced project will be submitted from the Bidder, the Affiant, their firm or corporation under the same or different name, and that such Bidder has no financial interest in the firm of another Bidder for the same work. Affiant also states that neither he/she, the firm, association nor corporation of the Bidder has either directly or indirectly entered into any agreement, participated in any collusion, nor otherwise taken any action in restraint of free competitive bidding in connection with this firm's Bid on the above-described project. Furthermore, neither the firm nor any of its officers are barred from participating in public contract lettings in the State of Florida or any other state.

DATED this 25 day of October, 2023.

[Signature]
Signature of Affiant

Craig Peplinski, P.E.
Printed Name of Affiant

Vice President
Printed Title of Affiant

Watson Civil Construction, Inc.
Full Legal Name of Consultant/Contractor

Sworn to (or affirmed) and subscribed before me by means of physical presence or online notarization, this 25 day of October, 2023, by Craig Peplinski, P.E., who is personally known to me or has produced _____ as identification.

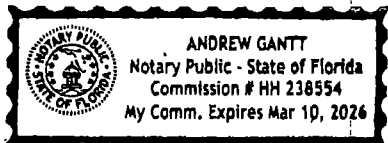

[Signature]
Notary Public
My Commission Expires: 3/10/2026

BIDDER MUST EXECUTE AND ATTACH THIS AFFADAVIT TO SUBMITTED BID.

BID NO: 23-94; CR 210 Widening from Trinity Way to Beachwalk Boulevard

ATTACHMENT "B"

CERTIFICATES AS TO CORPORATE PRINCIPAL

I, Franklin T. de la Serna, certify that I am the Secretary of the corporation named as Principal in the foregoing; that Franklin T. de la Serna, (Authorized Representative of Bidder) who signed the Bond(s) on behalf of the Bidder, was then Assistant Secretary (Title) of said corporation; that I know his/her signature; and his/her signature thereto is genuine; and that said bond(s) was duly signed, sealed, and attested to on behalf of said corporation by authority of its governing body.

[Handwritten Signature]
Signature of Secretary

Watson Civil Construction, Inc.
Full Legal Name of Corporation (Bidder)

STATE OF Florida

COUNTY OF Hillsborough

Before and by me, a Notary Public duly commissioned, qualified and acting personally, being duly sworn upon oath by means of physical presence or online notarization, Franklin T. de la Serna (Authorized Representative of Bidder) states that he/she is authorized to execute the foregoing Bid Bond on behalf of the Bidder named therein in favor of St. Johns County, Florida.

Subscribed and sworn to me on this 25 day of October, 2023, by the Authorized Representative of Bidder, who is personally known to me or has produced _____ as identification. Type and Number of I.D. produced: _____.

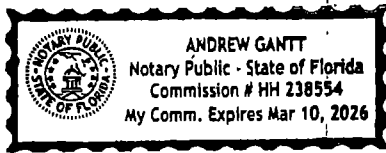

[Handwritten Signature]
Notary Public
My Commission Expires: 3/10/2026

(Attach Power of Attorney to original Bid Bond and Financial Statement of Surety Company)

TRAVELERS CASUALTY AND SURETY COMPANY OF AMERICA

HARTFORD, CONNECTICUT 06183

FINANCIAL STATEMENT AS OF JUNE 30, 2023

CAPITAL STOCK \$ 9,480,000

ASSETS	LIABILITIES & SURPLUS
BONDS STOCKS CASH AND INVESTED CASH OTHER INVESTED ASSETS SECURITIES LENDING REINVESTED COLLATERAL ASSETS INVESTMENT INCOME DUE AND ACCRUED PREMIUM BALANCES REINSURANCE RECOVERABLE NET DEFERRED TAX ASSET CURRENT FEDERAL AND FOREIGN INCOME TAXES RECOVERABLE GUARANTY FUNDS RECEIVABLE OR ON DEPOSIT RECEIVABLE FROM PARENTS, SUBSIDIARIES AND AFFILIATES OTHER ASSETS	LOSSES LOSS ADJUSTMENT EXPENSES COMMISSIONS OTHER EXPENSES TAXES, LICENSES AND FEES UNEARNED PREMIUMS ADVANCE PREMIUM POLICYHOLDER DIVIDENDS CEDED REINSURANCE NET PREMIUMS PAYABLE AMOUNTS WITHHELD / RETAINED BY COMPANY FOR OTHERS REMITTANCES AND ITEMS NOT ALLOCATED PROVISION FOR REINSURANCE PAYABLE FOR SECURITIES LENDING OTHER ACCRUED EXPENSES AND LIABILITIES TOTAL LIABILITIES CAPITAL STOCK PAID IN SURPLUS OTHER SURPLUS TOTAL SURPLUS TO POLICYHOLDERS
TOTAL ASSETS	TOTAL LIABILITIES & SURPLUS

STATE OF CONNECTICUT)
 COUNTY OF HARTFORD) 66.
 CITY OF HARTFORD)

MICHAEL J. DOODY, BEING DULY SWORN, SAYS THAT HE IS VICE PRESIDENT - FINANCE, OF TRAVELERS CASUALTY AND SURETY COMPANY OF AMERICA, AND THAT TO THE BEST OF HIS KNOWLEDGE AND BELIEF, THE FOREGOING IS A TRUE AND CORRECT STATEMENT OF THE FINANCIAL CONDITION OF SAID COMPANY AS OF THE 30TH DAY OF JUNE, 2023.

Michael J. Doody
 VICE PRESIDENT - FINANCE

Susan M. Weissleder
 NOTARY PUBLIC

SUBSCRIBED AND SWORN TO BEFORE ME THIS
 16TH DAY OF AUGUST, 2023

SUSAN M. WEISSLEDER
 Notary Public
 My Commission Expires November 30, 2027

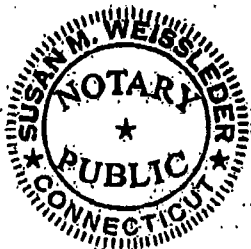

BID NO: 23-94; CR 210 Widening from Trinity Way to Beachwalk Boulevard

ATTACHMENT "C"

CONTRACTOR'S QUALIFICATIONS STATEMENT

I, Craig Peplinski, P.E., Vice President hereby certify that Watson Civil Construction, Inc.
(Authorized Company Representative Name & Title) (Full Legal Company Name)

has performed and is licensed in the State of Florida as a Certified General Contractor (CGC) or a Certified Underground Utility and Excavation Contractor (CUC). I also certify that the above named company is capable of bonding any Contract in excess of \$100,000.00 in value and shall perform the scope of work in accordance with the specifications stated in this Bid and that all information being submitted in response to this request is true and accurate to the best of my knowledge.

Authorized Bidder Representative:

 10/25/2023
Signature Date

Craig Peplinski, P.E., Vice President
Name & Title of Representative

BID NO: 23-94; CR 210 Widening from Trlnty Way to Beachwalk Boulevard

ATTACHMENT "D"

LICENSE / CERTIFICATION LIST

In the space below, the Bidder shall list all **current** licenses and certifications held, and FDOT Pre-qualification Letters for required FDOT Work Classes.

The bidder shall attach a copy of each current license, certifications, and/or FDOT pre-qualification letters listed below to this form.

License(s)/Certificate(s)/ Pre-Qualifications	License #	Issuing Agency	Expiration Date
State of Florida Business License	P14000038801	Florida Department of State	Not Applicable
Certified General Contractor (CGC)	CGC1513429	Florida DBPR	8/31/2024
Certified Underground Utility and Excavation Contractor (CUC)	CUC1224569	Florida DBPR	8/31/2024
FDOT Pre-Qualification (7) – Drainage	Watson Civil Construction, Inc.	FDOT	6/30/2024
FDOT Pre-Qualification (10) – Flexible Paving	Watson Civil Construction, Inc.	FDOT	6/30/2024
FDOT Pre-Qualification (11) – Grading	Watson Civil Construction, Inc.	FDOT	6/30/2024
FDOT Pre-Qualification (28) – Pavement Marking	Acme Barricades LC	FDOT	6/30/2024
FDOT Pre-Qualification (38) – Roadway Signing	Watson Civil Construction, Inc.	FDOT	6/30/2024
FDOT Pre-Qualification (40) – Sidewalk	Watson Civil Construction, Inc.	FDOT	6/30/2024

BID NO: 23-94; CR 210 Widening from Trinity Way to Beachwalk Boulevard

ATTACHMENT "E"

LIST OF PROPOSED SUB-CONTRACTORS / SUPPLIERS

Bidder shall submit any and all sub-contractors and/or major material suppliers proposed to perform any portion of the Work for review/approval by the County. Bidder shall attach any and all applicable licenses or certifications held by the proposed sub-contractor/supplier related to the portion of the Work for which they are proposed, as stated below. All subcontractors/suppliers are subject to the approval of the County.

Company Name	Work/Services to be Performed	Primary Contact Name	Contact Number and Email Address	Local Business (Yes/No)	Percentage (%) of Total Work/Services
Kudzue 3 Trucking, Inc.	Asphalt Paving	Jason Boatwright	912-576-4135 jboatwright@kudzue3.com	No	13.11%
Curb Systems of NE FL at St. Augustine, Inc.	Concrete Flatwork	Jennifer Teagle	904-829-3455 estimating@curbsystemsofnefl.com	Yes	3.88%
Belcorp, Inc.	Grassing	Pam Beverly	904-268-1236 pholton@belcorp-inc.com	No	0.23%
Acme Barricades, L.C.	Pavement Markings, MOT Devices, Signs	Russell Abell	813-623-2263 rabell@acmebarricades.com	No	2.65%
Pritchett Trucking, Inc.	Aggregate Haul, Trucking	Sam McLaughlin	352-434-7691 smclaughlin@pritchetttrucking.com	No	6.33%
County Materials Corp.	Drainage Pipe Supplier	Rick Bolinger	772-453-1103 rick.bolinger@countymaterials.com	No	4.76
Mack Industries, Inc.	Precast Structure Supplier	Brett Claflin	352-552-4629 belaflin@mackconcrete.com	No	2.32%
Radise International, L.C.	Geotechnical Testing	Newton Brooks	561-308-1013 newton.brooks@radise.net	No	1.06%

ATTACHMENT "F"

St. Johns County Board of County Commissioners

CONFLICT OF INTEREST DISCLOSURE FORM

Project BID Number/Description: Bid No 23-94; CR 210 Widening from Trinity Way to Beachwalk Boulevard

The term "conflict of interest" refers to situations in which financial or other considerations may adversely affect, or have the appearance of adversely affecting a consultant's/contractor's professional judgment in completing work for the benefit of St. Johns County ("County"). The bias such conflicts could conceivably impart may inappropriately affect the goals, processes, methods of analysis or outcomes desired by the County.

Consultants/Contractors are expected to safeguard their ability to make objective, fair, and impartial decisions when performing work for the benefit of the County. Consultants/Contractors, therefore must there avoid situations in which financial or other considerations may adversely affect, or have the appearance of adversely affecting the consultant's/contractor's professional judgement when completing work for the benefit of the County.

The mere appearance of a conflict may be as serious and potentially damaging as an actual distortion of goals, processes, methods of analysis or outcomes. Reports of conflicts based upon appearances can undermine public trust in ways that may not be adequately restored even when the mitigating facts of a situation are brought to light. Apparent conflicts, therefore, should be disclosed and evaluated with the same vigor as actual conflicts.

It is expressly understood that failure to disclose conflicts of interest as described herein may result in immediate disqualification from evaluation or immediate termination from work for the County.

Please check the appropriate statement:

- I hereby attest that the undersigned Respondent has no actual or potential conflict of interest due to any other clients, contracts, or property interests for completing work on the above referenced project.
- The undersigned Respondent, by attachment to this form, submits information which may be a potential conflict of interest due to other clients, contracts or property interests for completing work on the above referenced project.

Legal Name of Respondent: Watson Civil Construction, Inc.

Authorized Representative(s):  Craig Peplinski, P.E. Vice President
Signature Print Name/Title

 Aaron Keen, Chief Estimator
Signature Print Name/Title

St. Johns County Board of County Commissioners

ATTACHMENT "G"

DRUG-FREE WORKPLACE FORM

The undersigned firm, in accordance with Florida Statute 287.087 hereby certifies that

Watson Civil Construction, Inc. does:
Name of Firm

1. Publish a statement notifying employees that the unlawful manufacture, distribution, dispensing, possession or use of a controlled substance is prohibited in the workplace and specifying the actions that will be taken against employees for violations of such prohibition.
2. Inform employees about the danger of drug abuse in the workplace, the business' policy of maintaining a drug-free workplace, any available drug counseling, rehabilitation, employee assistance programs and the penalties that may be imposed upon employees for drug abuse violations.
3. Give each employee engaged in providing the contractual services that are described in St. Johns County's request for proposals a copy of the statement specified in paragraph 1.
4. In the statement specified in paragraph 1, notify the employees that, as a condition of working on the contractual services described in paragraph 3, the employee will abide by the terms of the statement and will notify the employer of any conviction of, or plea of guilty or nolo contendere to, any violation of Florida Statute 893, as amended, or of any controlled substance law of the United States or any state, for a violation occurring in the workplace no later than five (5) days after such conviction or plea.
5. Impose a sanction on, or require the satisfactory participation in a drug abuse assistance or rehabilitation program if such is available in the employee's community by, any employee who is so convicted.
6. Consistent with applicable provisions with State or Federal law, rule, or regulation, make a good faith effort to continue to maintain a drug-free workplace through implementation of paragraphs 1 through 5.

As the person authorized to sign this statement, I certify that this firm complies fully with the above requirements.



Signature

10/25/2023

Date

BID NO: 23-94; CR 210 Widening from Trinity Way to Beachwalk Boulevard

ATTACHMENT "H"

CERTIFICATE(S) OF INSURANCE
(Attach or insert copy here)

Respondents shall provide certificates of insurance as part of their submittal package. Certificates of insurance shall meet or exceed the requirements as described under Insurance.

Failure to provide proof of current insurance coverage or ability to obtain the required coverages may result in being deemed non-responsive and removed from further consideration.

Client#: 1901806

WATSOCIV

ACORD™

CERTIFICATE OF LIABILITY INSURANCE

DATE (MM/DD/YYYY) 6/22/2023

THIS CERTIFICATE IS ISSUED AS A MATTER OF INFORMATION ONLY AND CONFERS NO RIGHTS UPON THE CERTIFICATE HOLDER. THIS CERTIFICATE DOES NOT AFFIRMATIVELY OR NEGATIVELY AMEND, EXTEND OR ALTER THE COVERAGE AFFORDED BY THE POLICIES BELOW. THIS CERTIFICATE OF INSURANCE DOES NOT CONSTITUTE A CONTRACT BETWEEN THE ISSUING INSURER(S), AUTHORIZED REPRESENTATIVE OR PRODUCER, AND THE CERTIFICATE HOLDER.

IMPORTANT: If the certificate holder is an ADDITIONAL INSURED, the policy(ies) must have ADDITIONAL INSURED provisions or be endorsed. If SUBROGATION IS WAIVED, subject to the terms and conditions of the policy, certain policies may require an endorsement. A statement on this certificate does not confer any rights to the certificate holder in lieu of such endorsement(s).

PRODUCER: USI Insurance Services LLC -CL, 1000 Urban Center Drive, Suite 625, Birmingham, AL 35242, 205 969-5100. CONTACT NAME: Michelle Muscato, PHONE (A/C, No, Ext): 205 969-5100, FAX (A/C, No):, E-MAIL ADDRESS: michelle.muscato@usi.com. INSURER(S) AFFORDING COVERAGE: INSURER A: Continental Insurance Company (NAIC # 35289), INSURER B: National Fire Insurance Co. of Hartford (NAIC # 20478), INSURER C:, INSURER D:, INSURER E:, INSURER F:.

COVERAGES CERTIFICATE NUMBER: REVISION NUMBER:

THIS IS TO CERTIFY THAT THE POLICIES OF INSURANCE LISTED BELOW HAVE BEEN ISSUED TO THE INSURED NAMED ABOVE FOR THE POLICY PERIOD INDICATED. NOTWITHSTANDING ANY REQUIREMENT, TERM OR CONDITION OF ANY CONTRACT OR OTHER DOCUMENT WITH RESPECT TO WHICH THIS CERTIFICATE MAY BE ISSUED OR MAY PERTAIN, THE INSURANCE AFFORDED BY THE POLICIES DESCRIBED HEREIN IS SUBJECT TO ALL THE TERMS, EXCLUSIONS AND CONDITIONS OF SUCH POLICIES. LIMITS SHOWN MAY HAVE BEEN REDUCED BY PAID CLAIMS.

Table with columns: INSR LTR, TYPE OF INSURANCE, ADDL INSR, SUBR WVD, POLICY NUMBER, POLICY EFF (MM/DD/YYYY), POLICY EXP (MM/DD/YYYY), LIMITS. Rows include Commercial General Liability, Automobile Liability, Umbrella Liability, and Workers Compensation and Employers' Liability.

DESCRIPTION OF OPERATIONS / LOCATIONS / VEHICLES (ACORD 101, Additional Remarks Schedule, may be attached if more space is required) All insurance companies referenced herein are authorized to do business in the State of Florida.

CERTIFICATE HOLDER: For Information Only. CANCELLATION: SHOULD ANY OF THE ABOVE DESCRIBED POLICIES BE CANCELLED BEFORE THE EXPIRATION DATE THEREOF, NOTICE WILL BE DELIVERED IN ACCORDANCE WITH THE POLICY PROVISIONS. AUTHORIZED REPRESENTATIVE: [Signature]

ACORD 25 (2016/03) 1 of 1 #S40481252/M40431779 The ACORD name and logo are registered marks of ACORD JBCZP © 1988-2015 ACORD CORPORATION. All rights reserved.

BID NO: 23-94; CR 210 Widening from Trinity Way to Beachwalk Boulevard

ATTACHMENT "I"

RELEVANT EXPERIENCE OF BIDDER

Each Bidder must submit a list of projects showing relevant experience for the past five (5) years to the scope as described in this IFB. The information required shall include: dates of service, dollar amount of contract, name of individual, firm or agency, and a contact person name, title, phone number and email address. The County reserves the right to contract the project owners to verify experience of the Bidder.

Company/Agency Name: Florida Department of Transportation
Address: T7380 US 302 Bullfrog
Contact Person: Ghada Maghrebi
Phone: 813-612-3315 Fax: N/A
Email address: Ghada.Maghrebi@dot.state.fl.us
Project Description: Widening and reconstruction for about 4 miles of roadway with extensive drainage and utility relocations along with bridge and culvert box.
Contract \$ Amount: \$48,207,960.00
Date Completed: 12/3/2021

Company/Agency Name: Florida Department of Transportation
Address: T7424 CR 578 Hernando County
Contact Person: Bob Weimer - JBS Engineering Technical Services, Inc. (CEI)
Phone: 321-299-2349 Fax: N/A
Email address: robert@jbseng.com
Project Description: Construct 4 lanes of CR 578 on a new alignment; includes an 11 ft multi-use path that will connect to the Suncoast Train and accommodate widening to 3 lanes in each direction.
Contract \$ Amount: \$19,509,440.63
Date Completed: 4/12/2022

Company/Agency Name: Florida Department of Transportation
Address: E1R11 SR 542 Polk County
Contact Person: Daniel Foss
Phone: 813-612-3319 Fax: N/A
Email address: foss@eismanrusso.com
Project Description: Adding lanes, reconstruction and widening, drainage improvements, curb and gutter, signalization, ITS, lighting and utility work for 2.305 miles in Winter Haven.
Contract Amount: \$20,233,500.02
Date Completed: 12/21/2020

Company/Agency Name: Florida Department of Transportation
Address: T1650 US 17 Hardee County
Contact Person: Paul Wingard, P.E.
Phone: 239-278-5999 Fax: N/A
Email address: pwingard@kcaeng.com
Project Description: 4.9 miles of roadway widening, reconstruction, bridge widening and reconstruction, drainage and signing and pavement marking.
Contract Amount: \$23,500,000.00
Date Completed: 10/5/2018

Company/Agency Name: Florida Department of Transportation
Address: T2701 I-95 at Airport Road Duval County
Contact Person: Andre Sutherland, P.E.
Phone: 904-446-0262 Fax: N/A
Email address: A.Sutherland@gaiconsultants.com
Project Description: 1.659 miles of milling and resurfacing, base work, drainage improvements, curb and gutters, signals, lighting, bicycle path, ITS, specialty retaining wall and utility work.
Contract Amount: \$11,421,736.00
Date Completed: 7/27/2020

ATTACHMENT "J"

CLAIMS, LIENS, LITIGATION HISTORY

Bidders must complete all questions below and provide information requested as applicable. Failure to appropriately complete the questions below, or provide requested information may be grounds for disqualification. Any material misrepresentation of information may also be grounds for disqualification.

1. Within the past 7 years, has your organization filed suit or a formal claim against a project owner (as a prime or subcontractor) or been sued by or had a formal claim filed by an owner, subcontractor or supplier resulting from a project dispute?

Yes _____ No X

If yes, please attach additional sheet(s) to include:

- Description of every action Captions of the Litigation or Arbitration
- Amount at issue
- Name (s) of the attorneys representing all parties:
- Amount actually recovered, if any
- Name(s) of the project owner(s)/manager(s) to include address and phone number

2. List all pending litigation and or arbitration. Not Applicable.
3. List and explain all litigation and arbitration within the past seven (7) years - pending, resolved, dismissed, etc. Not Applicable.
4. Please list all liens (including Federal, State, and Local) which have been filed against your Company within the past seven (7) years. List in detail the type of Lien, date, amount and current status of each Lien. If none, so state. Not Applicable.

5. Have you ever abandoned a job, been terminated or had a performance/surety bond called to complete a job?

Yes _____ No X If yes, on separate sheet(s), provide an explanation of those instances.

6. For all claims filed against your company within the past five (5) years, have all been resolved satisfactorily with final judgment in favor of your company within 90 days of the date the judgment became final?

Yes _____ No _____ If no, on separate sheet(s), explain why. Not Applicable.

7. On separate sheet(s), list the status of all pending claims currently filed against your company. If none, so state. Not Applicable

8. Has a project owner ever withheld retainage, issued liquidated damages or made a claim against any Performance and Payment Bonds?

Yes _____ No X If yes, on separate sheet(s) explain in detail.

ATTACHMENT "K"

SWORN STATEMENT UNDER SECTION 287.133(3)(A), FLORIDA STATUTES ON PUBLIC ENTITY CRIMES

I, Craig Peplinski, P.E. ("Affiant"), being duly authorized by and on behalf of Watson Civil Construction, Inc. ("Respondent") hereby swears or affirms as follows:

- The principal business address of Respondent is: 319 West Town Place, Suite 25, St. Augustine, Florida 32092
- I am duly authorized as Vice President (Title) of Respondent.
- I understand that a public entity crime as defined in Section 287.133 of the Florida Statutes includes a violation of any state or federal law by a person with respect to and directly related to the transaction of business with any public entity in Florida or with an agency or political subdivision of any other state or with the United States, including, but not limited to, any bid, proposal, reply, or contract for goods or services, any lease for real property, or any contract for the construction or repair of a public building or public work, involving antitrust, fraud, theft, bribery, collusion, racketeering, conspiracy, or material misrepresentation.
- I understand that "convicted" or "conviction" is defined in Section 287.133 of the Florida Statutes to mean a finding of guilt or a conviction of a public entity crime, with or without an adjudication of guilt, in any federal or state trial court of record relating to charges brought by indictment or information after July 1, 1989, as a result of a jury verdict, non-jury trial, or entry of a plea of guilt or nolo contendere.
- I understand that "affiliate" is defined in Section 287.133 of the Florida Statutes to mean (1) a predecessor or successor of a person or a corporation convicted of a public entity crime, or (2) an entity under the control of any natural person who is active in the management of the entity and who has been convicted of a public entity crime, or (3) those officers, directors, executives, partners, shareholders, employees, members, and agents who are active in the management of an affiliate, or (4) a person or corporation who knowingly enters into a joint venture with a person who has been convicted of a public entity crime in Florida during the preceding 36 months.
- Neither the Respondent, nor any officer, director, executive, partner, shareholder, employee, member or agent who is active in the management of the Offeror or contractor, nor any affiliate of the Offeror or contractor has been convicted of a public entity crime subsequent to July 1, 1989. (Draw a line through paragraph 6 if paragraph 7 below applies.)
- ~~There has been a conviction of a public entity crime by the Respondent, or an officer, director, executive, partner, shareholder, employee, member or agent of the Respondent who is active in the management of the Respondent or an affiliate of the Respondent. A determination has been made pursuant to Section 287.133(3) by order of the Division of Administrative Hearings that it is not in the public interest for the name of the convicted person or affiliate to appear on the convicted vendor list. The name of the convicted person or affiliate is _____ A copy of the order of the Division of Administrative Hearings is attached to this statement. (Draw a line through paragraph 7 if paragraph 6 above applies.)~~

[Signature]
Signature of Affiant

Craig Peplinski, P.E., Vice President
Printed Name & Title of Affiant

Watson Civil Construction, Inc.
Full Legal Name of Respondent

10/25/2023
Date of Signature

Sworn to (or affirmed) and subscribed before me by means of physical presence or online notarization, this 25 day of October, 2023, by Affiant, who is personally known to me or has produced _____ as identification.

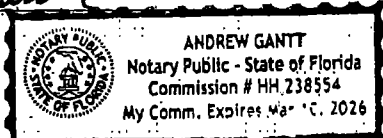
[Signature]
Notary Public

3/10/2026
My Commission Expires

BID NO: 23-94; CR 210 Widening from Trinity Way to Beachwalk Boulevard

ATTACHMENT "L"

NON-COLLUSION CERTIFICATION

St. Johns County requires, as a matter of policy, that any Firm receiving a contract or award resulting from the Invitation for Bid issued by St. Johns County shall make certification as below. Receipt of such certification, under oath, shall be a prerequisite to the award of contract and payment thereof.

I (we) hereby certify that if the contract is awarded to me, our firm, partnership or corporation, that no members of the elected governing body of St. Johns County nor any professional management, administrative official or employee of the County, nor members of his or her immediate family including spouse, parents or children, nor any person representing or purporting to represent any member or members of the elected governing body or other official, has solicited, has received or has been promised, directly or indirectly, any financial benefit including but not limited to a fee, commission, finder's fee, political contribution, goods or services in return for favorable review of any Bids submitted in response to the Invitation for Bid or in return for execution of a contract for performance or provision of services for which Bids are herein sought.

Handwritten Signature of Authorized Principal(s):

NAME (print): Craig Peplinski, P.E.

SIGNATURE:  _____

TITLE: Vice President

DATE: 10/25/2023

NAME OF FIRM/PARTNERSHIP/CORPORATION:

Watson Civil Construction, Inc.

ATTACHMENT "M"

E-VERIFY AFFIDAVIT

STATE OF Florida
COUNTY OF Hillsborough

I, Craig Peplinski, P.E. (hereinafter "Affiant"), being duly authorized by and on behalf of Watson Civil Construction, Inc. (hereinafter "Consultant/Contractor") hereby swears or affirms as follows:

1. Consultant/Contractor understands that E-Verify, authorized by Illegal Immigration Reform and Immigrant Responsibility Act of 1996 (IIRIRA), is a web-based system provided by the United States Department of Homeland Security, through which employers electronically confirm the employment eligibility of their employees.
2. For the duration of Contract No. 23-94 (hereinafter "Agreement"), in accordance with section 448.095, F.S., Consultant/Contractor shall utilize the U.S. Department of Homeland Security's E-Verify system to verify the employment eligibility of all new employees hired by the Consultant/Contractor and shall expressly require any subcontractors performing work or providing services pursuant to the Agreement to likewise utilize the U.S. Department of Homeland Security's E-Verify system to verify the employment eligibility of all new employees hired by the subcontractor.
3. Consultant/Contractor shall comply with all applicable provisions of section 448.095, F.S., and will incorporate in all subcontracts the obligation to comply with section 448.095, F.S.
4. Consultant/Contractor understands and agrees that its failure to comply with all applicable provisions of section 448.095, F.S. or its failure to ensure that all employees and subcontractors performing work under the Agreement are legally authorized to work in the United States and the State of Florida constitute a breach of the Agreement for which St. Johns County may immediately terminate the Agreement without notice and without penalty. The Consultant/Contractor further understands and agrees that in the event of such termination, Consultant/Contractor shall be liable to the St. Johns County for any costs incurred by the St. Johns County resulting from Consultant/Contractor's breach.

DATED this 25 day of October, 2023

[Signature]
Signature of Affiant

Craig Peplinski, P.E.
Printed Name of Affiant

Vice President
Printed Title of Affiant

Watson Civil Construction, Inc.
Full Legal Name of Consultant/Contractor

Sworn to (or affirmed) and subscribed before me by means of physical presence or online notarization; this 25 day of October, 2023, by _____, who is personally known to me or has produced _____ as identification.

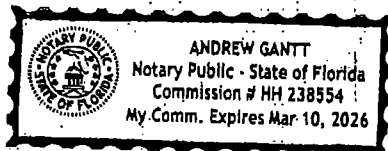

[Signature]
Notary Public
My Commission Expires: 3/10/2026

BID NO: 23-94; CR 210 Widening from Trinity Way to Beachwalk Boulevard

ATTACHMENT "N"

CERTIFICATE OF COMPLIANCE WITH FLORIDA TRENCH SAFETY ACT

Bidder acknowledges that he is solely responsible for complying with the Florida Trench Safety Act (ACT) and Occupational Safety and Health Administrations excavation safety standard 29 CFR 1926.650 (Subpart P as amended) and the St. Johns County Trenching and Excavation Safety Program. If there is a conflict between the ACT and the St. Johns County Trenching and Excavation Safety Program, the more stringent requirement would apply. Bidder further acknowledges that included in the various items of the proposal and in the Total Bid Price are costs for complying with the Florida Trench Safety Act (90-96, Laws of Florida) effective October 1, 1990 and the Occupational Safety and Health Administrations excavation safety standard.

Handwritten Signature of Authorized Principal(s):

NAME (print): Craig Peplinski, P.E.

SIGNATURE: 

TITLE: Vice President

DATE: 10/25/2023

NAME OF FIRM/PARTNERSHIP/CORPORATION:

Watson Civil Construction, Inc.

ATTACHMENT "O"

LOCAL PREFERENCE

Bidders must complete and submit **Attachment O**, indicating whether or not the Bidder is submitting for consideration of Local Preference. Any Bidder that meets the criteria of a Local Business, in accordance with Section 16.3.1 of the SJC Purchasing Policy, must submit all documentation required to support consideration as Local Business, for the Bidder as well as any proposed sub-contractors who are submitted for consideration of Local Preference as specified on Attachment O.

Any Bidder submitting for consideration of Local Preference either through their own qualifications, or through that of proposed sub-contractors must also submit documentation to demonstrate that at least fifty percent (50%) of all Work shall be self-performed, or performed by sub-contractors that meet the criteria of a Local Business.

In order to qualify for local preference Bidder must provide sufficient documentation to demonstrate:

- A physical, brick and mortar place of business located within the geographic boundaries of St. Johns County, with a valid mailing address, in an area zoned for the conduct of such business, from which the Bidder has operated or performed business on a day-to-day basis that is substantially similar to those specified in the solicitation for a period of at least one (1) calendar year prior to the issuance of the solicitation. No PO Boxes shall be accepted.
- Local address above must be registered as the Bidder’s principal place of business with the Divisions of Corporations Florida Department of State for at least one (1) calendar year prior to the issuance of this RFQ.
- Submit current and valid Local Business Tax Receipt, and must have Local Business Tax Receipts issued by the St. Johns County Tax Collector from at least one (1) calendar year prior to issuance of this RFQ.
- Must qualify as a local business as shown above **AND** self-perform a minimum of fifty percent (50%) of all services under the awarded Contract, or must have a minimum of fifty percent (50%) of all services performed by qualified local businesses as sub-contractors.

Bidder **is** a Local Business as defined in Section 16.3.1, SJC Purchasing Policy _____ X

If Bidder selects this option, by signing below, Bidder certifies that the firm qualifies as a local business in accordance with the requirements stated above, OR certifies that the submitted local business proposed as sub-contractors meet the requirements for local preference AND that a minimum of fifty percent (50%) of all services shall be performed by local businesses as proposed.

Bidder is **not** a Local Business as defined in Section 16.3.1, SJC Purchasing Policy _____

If Bidder selects this option, Bidder is not seeking consideration for local preference, and is not required to submit the documentation provided above.

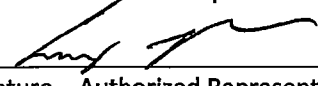

 Signature – Authorized Representative

Craig Peplinski, P.E., Vice President

 Printed Name & Title

10/25/2023

 Date of Signature

BID NO: 23-94; CR 210 Widening from Trinity Way to Beachwalk Boulevard

**ATTACHMENT – "P" ADDENDUM #4
REVISED SCHEDULE OF VALUES - EIGHTEEN (18) MONTHS COMPLETION TIME**

Bidders shall complete and submit with their Bid Proposal this Schedule of Values to demonstrate the breakdown of costs included in the submitted Lump Sum Bid Price. Quantities provided herein are estimates only and Bidders are responsible for appropriately estimating quantities for inclusion in the

Bid Item	Pay Item	Description	Unit	Quantity	Cost Per Unit	Total Cost
General						
1	101 1	MOBILIZATION	LS	1	\$1,181,000.00	\$ 1,181,000.00
2	101 2	MAINTENANCE OF TRAFFIC	LS	1	\$2,184,200.00	\$ 2,184,200.00
3	104 10 3	SEDIMENT BARRIER	LF	6,655	\$ 2.20	\$ 14,641.00
4	104 12	STAKED TURBIDITY BARRIER	LF	690	\$ 8.00	\$ 5,520.00
5	104 18	INLET PROTECTION SYSTEM	EA	47	\$ 160.00	\$ 7,520.00
6	110 1 1	CLEARING AND GRUBBING	AC	10	\$ 99,000.00	\$ 990,000.00
7	110 4 10	REMOVAL OF EXISTING CONCRETE	SY	1,985	\$ 26.00	\$ 51,610.00
8	0107 2	MOWING (18 MONTH DURATION)	AC	230	\$ 105.00	\$ 24,150.00
9	0107 1	LITTER REMOVAL	AC	312	\$ 75.00	\$ 23,400.00
General Sub-Total						\$ 4,482,041.00
Roadway						
10	120 1	REGULAR EXCAVATION	CY	3,685	\$ 16.00	\$ 58,960.00
11	120 6	EMBANKMENT	CY	21,194	\$ 31.00	\$ 657,014.00
12	160 4	TYPE B STABILIZATION	SY	40,679	\$ 16.00	\$ 650,864.00
13	285 711	OPTIONAL BASE GROUP 11, 12" LIMEROCK	SY	39,472	\$ 38.00	\$ 1,499,936.00
14	327 70 6	MILLING EXISTING ASPHALT PAVEMENT, 1 1/2" AVG DEPTH	SY	5,217	\$ 3.10	\$ 16,172.70
15	334 1 12	SUPERPAVE ASPHALT PAVEMENT, TRAFFIC B (3")	TN	5,960	\$ 133.00	\$ 792,680.00
16	334 1 12	SUPERPAVE ASPHALT PAVEMENT, TRAFFIC B (1.5")	TN	3,410	\$ 181.00	\$ 617,210.00
17	520 1 10	CONCRETE CURB & GUTTER, TYPE F	LF	9,278	\$ 31.00	\$ 287,618.00
18	520 5 41	TRAFFIC SEPARATOR CONCRETE - TYPE IV, 4' WIDE	LF	1,380	\$ 31.00	\$ 42,780.00
19	522 1	CONCRETE SIDEWALK AND DRIVEWAYS, 4" THICK	SY	3,316	\$ 53.00	\$ 175,748.00
20	522 2	CONCRETE SIDEWALK AND DRIVEWAYS, 6" THICK	SY	490	\$ 80.00	\$ 39,200.00
21	522	CONCRETE SIDEWALK WITH THICKENED EDGE, 4" THICK	SY	156	\$ 77.00	\$ 12,012.00
22	527 2	DETECTABLE WARNINGS	SF	251	\$ 40.00	\$ 10,040.00

23	570 1 1	PERFORMANCE TURF	SY	13,990	\$ 3.80	\$ 53,162.00
24	570 1 2	PERFORMANCE TURF, SOD	SY	6,012	\$ 7.00	\$ 42,084.00
25	0515 2311	PEDESTRIAN RAILING (ALUMINUM)	LF	260	\$ 75.00	\$ 19,500.00
Roadway Sub-Total						\$ 4,974,980.70
Drainage						
26	425 1 311	INLETS, CURB, TYPE P-1, <10'	EA	9	\$ 12,000.00	\$ 108,000.00
27	425 1 315	INLETS, CURB TYPE P-1, >10'	EA	1	\$ 12,600.00	\$ 12,600.00
28	425 1 321	INLETS, CURB, TYPE P-2, <10'	EA	7	\$ 13,900.00	\$ 97,300.00
29	425 1 411	INLETS, CURB, TYPE J-1, <10'	EA	2	\$ 11,750.00	\$ 23,500.00
30	425 1 412	INLETS, CURB, TYPE J-1, >10'	EA	4	\$ 14,400.00	\$ 57,600.00
31	0425 1315	INLETS, CURB, TYPE 1 TOP ONLY	EA	2	\$ 5,500.00	\$ 11,000.00
32	425 1 421	INLETS, CURB, TYPE J-2, <10'	EA	7	\$ 14,400.00	\$ 100,800.00
33	425 1 471	INLETS, CURB, TYPE P-7, <10'	EA	5	\$ 11,500.00	\$ 57,500.00
34	425 1 521	INLETS, DT BOT, TYPE C, <10'	EA	3	\$ 6,300.00	\$ 18,900.00
35	0425 1524	INLETS, DT BOT, TYPE C, >10'	EA	1	\$ 11,800.00	\$ 11,800.00
36	425 1 541	INLETS, DT BOT, TYPE D, <10'	EA	5	\$ 8,300.00	\$ 41,500.00
37	425 2 61	MANHOLES, P-8, <10'	EA	1	\$ 11,300.00	\$ 11,300.00
38	425 2 92	MANHOLES, J-8, >10'	EA	4	\$ 13,100.00	\$ 52,400.00
39	0425 2 91	MANHOLES, J-8, <10'	EA	1	\$ 10,700.00	\$ 10,700.00
40	430 175 118	PIPE CULVERT, OPTIONAL MATERIAL, ROUND 18"	LF	1,320	\$ 177.00	\$ 233,640.00
41	430 175 124	PIPE CULVERT, OPTIONAL MATERIAL, ROUND 24"	LF	274	\$ 198.00	\$ 54,252.00
42	430 175 130	PIPE CULVERT, OPTIONAL MATERIAL, ROUND 30"	LF	468	\$ 260.00	\$ 121,680.00
43	430 175 136	PIPE CULVERT, OPTIONAL MATERIAL, ROUND 36"	LF	748	\$ 318.00	\$ 237,864.00
44	430 175 142	PIPE CULVERT, OPTIONAL MATERIAL, ROUND 42"	LF	843	\$ 369.00	\$ 311,067.00
45	430 175 148	PIPE CULVERT, OPTIONAL MATERIAL, ROUND 48"	LF	855	\$ 443.00	\$ 378,765.00
46	430 174 218	PIPE CULVERT, OPTIONAL MATERIAL, OTHER SHAPE, ELLIP/ARCH, 14" x 23"	LF	442	\$ 189.00	\$ 83,538.00
47	430 174 224	PIPE CULVERT, OPTIONAL MATERIAL, OTHER SHAPE, ELLIP/ARCH, 19" x 30"	LF	325	\$ 240.00	\$ 78,000.00
48	430 530 100	STRAIGHT CONCRETE ENDWALL, 30", QUAD	EA	2	\$ 30,000.00	\$ 60,000.00
49	430 984 625	MITERED END SECTION, OPTIONAL - ELLIP/ARCH, 14" x 23"	EA	6	\$ 2,500.00	\$ 15,000.00
50	430 984 629	MITERED END SECTION, OPTIONAL - ELLIP/ARCH, 19" x 30"	EA	2	\$ 3,000.00	\$ 6,000.00

51	425	CONCRETE FLUME	EA	2	\$ 2,500.00	\$ 5,000.00
52	0425 11	MODIFY EXISTING DRAINAGE STRUCTURE (POND CONTROL)	EA	1	\$ 2,000.00	\$ 2,000.00
53	425	P-BOTTOM W/ 8" TOP SLAB	EA	1	\$ 11,300.00	\$ 11,300.00
Drainage Sub-total						\$ 2,213,006.00
Signing and Pavement Marking						
54	700 1 11	SINGLE POST SIGN, F&I GROUND MOUNT, UP TO 12 SF	EA	39	\$ 515.00	\$ 20,085.00
55	700 1 12	SINGLE POST SIGN, F&I GROUND MOUNT, 12-20 SF	EA	2	\$ 2,100.00	\$ 4,200.00
56	700 1 50	SINGLE POST SIGN, RELOCATE	EA	1	\$ 455.00	\$ 455.00
57	700 1 60	SINGLE POST SIGN, REMOVE	EA	17	\$ 77.00	\$ 1,309.00
58	706 1 3	RAISED PAVEMENT MARKER, TYPE B	EA	917	\$ 7.00	\$ 6,419.00
59	711 11 102	THERMOPLASTIC, STANDARD, WHITE, SOLID 8"	LF	437	\$ 1.90	\$ 830.30
60	711 11 123	THERMOPLASTIC, STANDARD, WHITE, SOLID 12"	LF	1,697	\$ 7.00	\$ 11,879.00
61	711 11 124	THERMOPLASTIC, STANDARD, WHITE, SOLID 18"	LF	513	\$ 9.35	\$ 4,796.55
62	711 11 125	THERMOPLASTIC, STANDARD, WHITE, SOLID 24"	LF	450	\$ 11.70	\$ 5,265.00
63	711 11 141	THERMOPLASTIC, STANDARD, WHITE, 2-4 DOTTED GUIDELINE, 6"	GM	0.51	\$ 2,950.00	\$ 1,504.50
64	711 11 160	THERMOPLASTIC, PREFORMED, WHITE, MESSAGE	EA	33	\$ 300.00	\$ 9,900.00
65	711 11 170	THERMOPLASTIC, PREFORMED, WHITE, ARROW	EA	101	\$ 146.00	\$ 14,746.00
66	711 11 224	THERMOPLASTIC, STANDARD, YELLOW, SOLID 18"	LF	170	\$ 2.65	\$ 450.50
67	711 15 101	THERMOPLASTIC, STANDARD OG ASPHALT, WHITE, SOLID, 6"	GM	3.77	\$ 8,800.00	\$ 33,176.00
68	711 15 131	THERMOPLASTIC, STANDARD OG ASPHALT, WHITE, SKIP, 6" 10-30 SKIP	GM	2.87	\$ 2,950.00	\$ 8,466.50
69	711 15 201	THERMOPLASTIC, STANDARD OG ASPHALT, YELLOW, SOLID, 6"	GM	2.05	\$ 8,800.00	\$ 18,040.00
Signing and Marking Sub-Total						\$ 141,522.35
Total Lump Sum Bid Price						\$ 11,811,550.05

BID NO: 23-94; CR 210 Widening from Trinity Way to Beachwalk Boulevard

BID BOND

STATE OF FLORIDA
COUNTY OF ST. JOHNS

KNOW ALL MEN BY THESE PRESENTS, that Watson Civil Construction, Inc. as Principal, and Travelers Casualty and Surety Company of America as Surety, are held and firmly bound unto St. Johns County, Florida, in the penal sum of Five percent of the amount bid Dollars (\$ 5% of the amount bid) lawful money of the United States, we bind ourselves, our heirs, executors, administrators, and successors, jointly and severally, firmly by these presents.

THE CONDITION OF THIS OBLIGATIONS IS SUCH that whereas the Principal has submitted the accompanying Bid, dated October 11th, 2023.

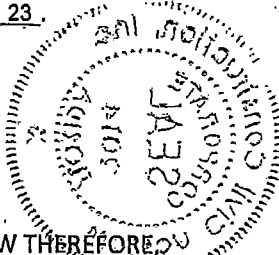

For
CR 210 Widening from Trinity Way to Beachwalk Boulevard
St. Johns County, Florida

NOW THEREFORE

- (a) If the Principal shall not withdraw said Bid within ninety (90) days after Bid Award date, and shall within ten (10) days after prescribed forms are presented to him for signature, enter into a written Contract with the County in accordance with the Bid as accepted, and give Bond with good and sufficient Surety or Sureties, as may be required, for the faithful performance and proper fulfillment of such Contract, then the above obligations shall be void and of no effect, otherwise to remain in full force and virtue.
- (b) In the event of the withdrawal of said Bid within the period specified, or the failure to enter into such Contract and give such Bond within the time specified, if the Principal shall pay the County the difference between the amount specified, in said Bid and the amount for which the County may procure the required Work and supplies, if the latter amount be in excess of the former, then the above obligations shall be void and of no effect, otherwise to remain in full force and virtue.

IN WITNESS WHEREOF, the above bounded parties have executed this instrument under their several seals, this 11th day of October A.D., 2023, the name and corporate seal of each corporate party being hereto affixed and these presents duly signed by its undersigned representative, pursuant to authority of its governing body.

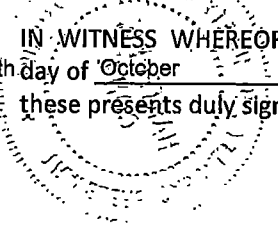



**Travelers Casualty and Surety Company of America
Travelers Casualty and Surety Company
St. Paul Fire and Marine Insurance Company**

POWER OF ATTORNEY

KNOW ALL MEN BY THESE PRESENTS: That Travelers Casualty and Surety Company of America, Travelers Casualty and Surety Company, and St. Paul Fire and Marine Insurance Company are corporations duly organized under the laws of the State of Connecticut (herein collectively called the "Companies"), and that the Companies do hereby make, constitute and appoint **KEVIN R WOJTWICZ** of **ST PETERSBURG Florida**, their true and lawful Attorney(s)-in-Fact to sign, execute, seal and acknowledge any and all bonds, recognizances, conditional undertakings and other writings obligatory in the nature thereof on behalf of the Companies in their business of guaranteeing the fidelity of persons, guaranteeing the performance of contracts and executing or guaranteeing bonds and undertakings required or permitted in any actions or proceedings allowed by law.

IN WITNESS WHEREOF, the Companies have caused this instrument to be signed, and their corporate seals to be hereto affixed, this **21st** day of **April**, 2021.



State of Connecticut.

City of Hartford ss.

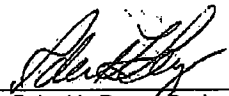
By: 
Robert L. Raney, Senior Vice President

On this the **21st** day of **April**, 2021, before me personally appeared **Robert L. Raney**, who acknowledged himself to be the Senior Vice President of each of the Companies, and that he, as such, being authorized so to do, executed the foregoing instrument for the purposes therein contained by signing on behalf of said Companies by himself as a duly authorized officer.

IN WITNESS WHEREOF, I hereunto set my hand and official seal.

My Commission expires the **30th** day of **June**, 2026

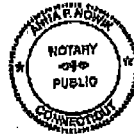

Anna P. Nowik, Notary Public

This Power of Attorney is granted under and by the authority of the following resolutions adopted by the Boards of Directors of each of the Companies, which resolutions are now in full force and effect, reading as follows:

RESOLVED, that the Chairman, the President, any Vice Chairman, any Executive Vice President, any Senior Vice President, any Vice President, any Second Vice President, the Treasurer, any Assistant Treasurer, the Corporate Secretary or any Assistant Secretary may appoint Attorneys-in-Fact and Agents to act for and on behalf of the Company and may give such appointee such authority as his or her certificate of authority may prescribe to sign with the Company's name and seal with the Company's seal bonds, recognizances, contracts of indemnity, and other writings obligatory in the nature of a bond, recognizance, or conditional undertaking, and any of said officers or the Board of Directors at any time may remove any such appointee and revoke the power given him or her; and it is

FURTHER RESOLVED, that the Chairman, the President, any Vice Chairman, any Executive Vice President, any Senior Vice President or any Vice President may delegate all or any part of the foregoing authority to one or more officers or employees of this Company, provided that each such delegation is in writing and a copy thereof is filed in the office of the Secretary; and it is

FURTHER RESOLVED, that any bond, recognizance, contract of indemnity, or writing obligatory in the nature of a bond, recognizance, or conditional undertaking shall be valid and binding upon the Company when (a) signed by the President, any Vice Chairman, any Executive Vice President, any Senior Vice President or any Vice President, any Second Vice President, the Treasurer, the Corporate Secretary or any Assistant Secretary and duly attested and sealed with the Company's seal by a Secretary or Assistant Secretary; or (b) duly executed (under seal, if required) by one or more Attorneys-in-Fact and Agents pursuant to the power prescribed in his or her certificate or their certificates of authority or by one or more Company officers pursuant to a written delegation of authority; and it is

FURTHER RESOLVED, that the signature of each of the following officers: President, any Executive Vice President, any Senior Vice President, any Vice President, any Assistant Vice President, any Secretary, any Assistant Secretary, and the seal of the Company may be affixed by facsimile to any Power of Attorney or to any certificate relating thereto appointing Resident Vice Presidents, Resident Assistant Secretaries or Attorneys-in-Fact for purposes only of executing and attesting bonds and undertakings and other writings obligatory in the nature thereof, and any such Power of Attorney or certificate bearing such facsimile signature or facsimile seal shall be valid and binding upon the Company and any such power so executed and certified by such facsimile signature and facsimile seal shall be valid and binding on the Company in the future with respect to any bond or understanding to which it is attached.

I, **Kevin E. Hughes**, the undersigned, Assistant Secretary of each of the Companies, do hereby certify that the above and foregoing is a true and correct copy of the Power of Attorney executed by said Companies, which remains in full force and effect.

Dated this **11th** day of **October**, 2023



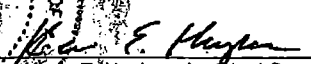

Kevin E. Hughes, Assistant Secretary

**To verify the authenticity of this Power of Attorney, please call us at 1-800-421-3880.
Please refer to the above-named Attorney(s)-in-Fact and the details of the bond to which this Power of Attorney is attached.**

Duplicate

BID NO: 23-94; CR 210 Widening from Trinity Way to Beachwalk Boulevard

BID BOND

STATE OF FLORIDA
COUNTY OF ST. JOHNS

KNOW ALL MEN BY THESE PRESENTS, that Watson Civil Construction, Inc. as Principal, and Travelers Casualty and Surety Company of America as Surety, are held and firmly bound unto St. Johns County, Florida, in the penal sum of Five percent of the amount bid Dollars (\$ 5% of the amount bid) lawful money of the United States, we bind ourselves, our heirs, executors, administrators, and successors, jointly and severally, firmly by these presents.

THE CONDITION OF THIS OBLIGATIONS IS SUCH that whereas the Principal has submitted the accompanying Bid, dated ^{October} 11th, 20 23.

For
CR 210 Widening from Trinity Way to Beachwalk Boulevard
St. Johns County, Florida

NOW THEREFORE,

- (a) If the Principal shall not withdraw said Bid within ninety (90) days after Bid Award date, and shall within ten (10) days after prescribed forms are presented to him for signature, enter into a written Contract with the County in accordance with the Bid as accepted, and give Bond with good and sufficient Surety or Sureties, as may be required, for the faithful performance and proper fulfillment of such Contract, then the above obligations shall be void and of no effect, otherwise to remain in full force and virtue.
- (b) In the event of the withdrawal of said Bid within the period specified, or the failure to enter into such Contract and give such Bond within the time specified, if the Principal shall pay the County the difference between the amount specified, in said Bid and the amount for which the County may procure the required Work and supplies, if the latter amount be in excess of the former, then the above obligations shall be void and of no effect, otherwise to remain in full force and virtue.

IN WITNESS WHEREOF, the above bounded parties have executed this instrument under their several seals, this 11th day of October A.D., 2023, the name and corporate seal of each corporate party being hereto affixed and these presents duly signed by its undersigned representative, pursuant to authority of its governing body.

Duplicate

BID NO: 23-94; CR 210 Widening from Trinity Way to Beachwalk Boulevard

WITNESSES:

(If Sole Ownership or Partnership two (2) Witnesses required).
(If Corporation, Secretary only will attest and affix seal).

WITNESSES:

Andrea Alessi
Paul J. Parkhurst
Erk

Watson Civil Construction, Inc. John D. Watson P.E.

PRINCIPAL:

Watson Civil Construction, Inc.

NAME OF FIRM:

[Signature]

SIGNATURE OF AUTHORIZED OFFICER (AFFIX SEAL)

Asst. Secretary

TITLE

319 West Town Place, Suite 25

BUSINESS ADDRESS

St. Augustine, FL 32092

CITY STATE

Travelers Casualty and Surety Company of America

SURETY:

Travelers Casualty and Surety Company of America
CORPORATE SURETY

ATTORNEY-IN-FACT (AFFIX SEAL)

1000 Central Ave. Ste 200

BUSINESS ADDRESS

St. Petersburg FL 33705

CITY STATE

Nielson, Wojtowicz, Neu & Associates, Inc.

NAME OF LOCAL INSURANCE AGENCY

WITNESS:

Amy Scott

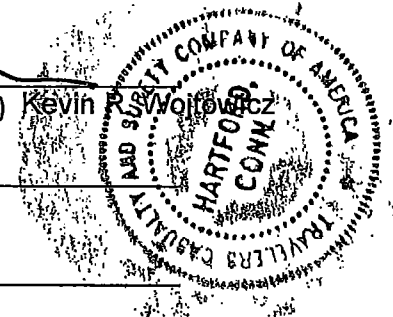
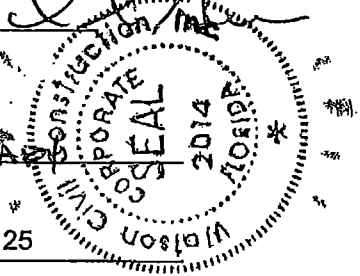

Duplicate



Travelers Casualty and Surety Company of America
Travelers Casualty and Surety Company
St. Paul Fire and Marine Insurance Company

POWER OF ATTORNEY

KNOW ALL MEN BY THESE PRESENTS: That Travelers Casualty and Surety Company of America, Travelers Casualty and Surety Company, and St. Paul Fire and Marine Insurance Company are corporations duly organized under the laws of the State of Connecticut (herein collectively called the "Companies"), and that the Companies do hereby make, constitute and appoint **KEVIN R WOJTCWICZ** of **ST PETERSBURG**, Florida, their true and lawful Attorney(s)-in-Fact to sign, execute, seal and acknowledge any and all bonds, recognizances, conditional undertakings and other writings obligatory in the nature thereof on behalf of the Companies in their business of guaranteeing the fidelity of persons, guaranteeing the performance of contracts and executing or guaranteeing bonds and undertakings required or permitted in any actions or proceedings allowed by law.

IN WITNESS WHEREOF, the Companies have caused this Instrument to be signed, and their corporate seals to be hereto affixed, this 21st day of April, 2021.



State of Connecticut

City of Hartford ss.

By:
Robert L. Raney, Senior Vice President

On this the 21st day of April, 2021, before me personally appeared Robert L. Raney, who acknowledged himself to be the Senior Vice President of each of the Companies, and that he, as such, being authorized so to do, executed the foregoing instrument for the purposes therein contained by signing on behalf of said Companies by himself as a duly authorized officer.

IN WITNESS WHEREOF, I hereunto set my hand and official seal.

My Commission expires the 30th day of June, 2026



Anna P. Nowik, Notary Public

This Power of Attorney is granted under and by the authority of the following resolutions adopted by the Boards of Directors of each of the Companies, which resolutions are now in full force and effect, reading as follows:

RESOLVED, that the Chairman, the President, any Vice Chairman, any Executive Vice President, any Senior Vice President, any Vice President, any Second Vice President, the Treasurer, any Assistant Treasurer, the Corporate Secretary or any Assistant Secretary may appoint Attorneys-in-Fact and Agents to act for and on behalf of the Company and may give such appointee such authority as his or her certificate of authority may prescribe to sign with the Company's name and seal with the Company's seal bonds, recognizances, contracts of indemnity, and other writings obligatory in the nature of a bond, recognizance, or conditional undertaking, and any of said officers or the Board of Directors at any time may remove any such appointee and revoke the power given him or her; and it is

FURTHER RESOLVED, that the Chairman, the President, any Vice Chairman, any Executive Vice President, any Senior Vice President or any Vice President may delegate all or any part of the foregoing authority to one or more officers or employees of this Company, provided that each such delegation is in writing and a copy thereof is filed in the office of the Secretary; and it is

FURTHER RESOLVED, that any bond, recognizance, contract of indemnity, or writing obligatory in the nature of a bond, recognizance, or conditional undertaking shall be valid and binding upon the Company when (a) signed by the President, any Vice Chairman, any Executive Vice President, any Senior Vice President or any Vice President, any Second Vice President, the Treasurer, any Assistant Treasurer, the Corporate Secretary or any Assistant Secretary and duly attested and sealed with the Company's seal by a Secretary or Assistant Secretary; or (b) duly executed (under seal, if required) by one or more Attorneys-in-Fact and Agents pursuant to the power prescribed in his or her certificate or their certificates of authority or by one or more Company officers pursuant to a written delegation of authority; and it is

FURTHER RESOLVED, that the signature of each of the following officers: President, any Executive Vice President, any Senior Vice President, any Vice President, any Assistant Vice President, any Secretary, any Assistant Secretary, and the seal of the Company may be affixed by facsimile to any Power of Attorney or to any certificate relating thereto appointing Resident Vice Presidents, Resident Assistant Secretaries or Attorneys-in-Fact for purposes only of executing and attesting bonds and undertakings and other writings obligatory in the nature thereof, and any such Power of Attorney or certificate bearing such facsimile signature or facsimile seal shall be valid and binding upon the Company and any such power so executed and certified by such facsimile signature and facsimile seal shall be valid and binding on the Company in the future with respect to any bond or understanding to which it is attached.

I, Kevin E. Hughes, the undersigned, Assistant Secretary of each of the Companies, do hereby certify that the above and foregoing is a true and correct copy of the Power of Attorney executed by said Companies, which remains in full force and effect.

Dated this 11th day of October, 2023



Kevin E. Hughes, Assistant Secretary

To verify the authenticity of this Power of Attorney, please call us at 1-800-421-3880.
Please refer to the above-named Attorney(s)-in-Fact and the details of the bond to which this Power of Attorney is attached.

SEALED BID MAILING LABEL

**Cut along the outer border and affix this label
to your sealed bid envelope to identify it as a
"Sealed BID"**

SEALED BID • DO NOT OPEN	
SEALED BID NO.:	BID NO: 23-94
BID TITLE:	CR 210 Widening from Trinity Way to Beachwalk Boulevard
DUE DATE/TIME:	By 2:00PM – October ²⁵11, 2023
SUBMITTED BY:	Watson Civil Construction, Inc.
	Company Name
	319 West Town Place, Suite 25 St. Augustine, Florida 32092
	Company Address
	Company Address
DELIVER TO:	St. Johns County Purchasing Division 500 San Sebastian View St. Augustine FL 32084



END OF DOCUMENT

Ron DeSantis, Governor

Melanie S. Griffin, Secretary



STATE OF FLORIDA
DEPARTMENT OF BUSINESS AND PROFESSIONAL REGULATION

CONSTRUCTION INDUSTRY LICENSING BOARD

THE GENERAL CONTRACTOR HEREIN IS CERTIFIED UNDER THE
PROVISIONS OF CHAPTER 489, FLORIDA STATUTES

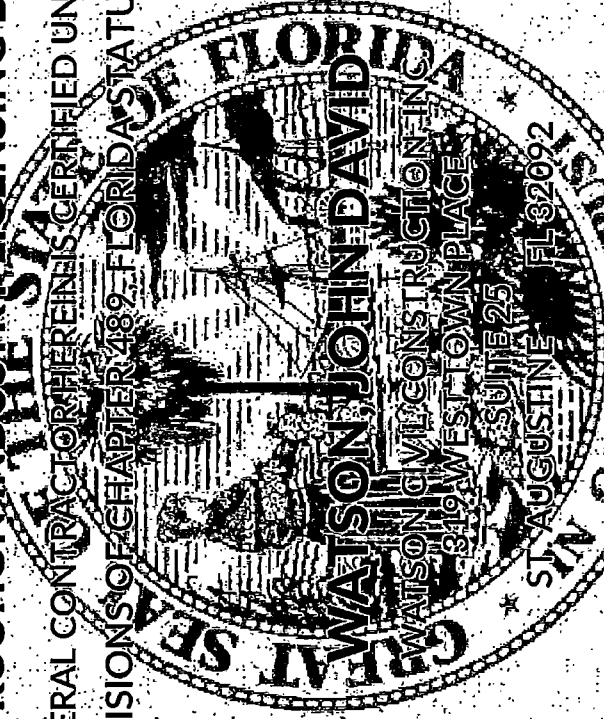

LICENSE NUMBER: CCC1513429

EXPIRATION DATE: AUGUST 31, 2024

Always verify licenses online at MyFloridaLicense.com



Do not alter this document in any form.

This is your license. It is unlawful for anyone other than the licensee to use this document.

Ron DeSantis, Governor



Melanie S. Griffin, Secretary



STATE OF FLORIDA
DEPARTMENT OF BUSINESS AND PROFESSIONAL REGULATION
CONSTRUCTION INDUSTRY LICENSING BOARD

THE UNDERGROUND UTILITY & EXCAVATION CO. HEREIN IS CERTIFIED UNDER THE
PROVISIONS OF CHAPTER 489, FLORIDA STATUTES

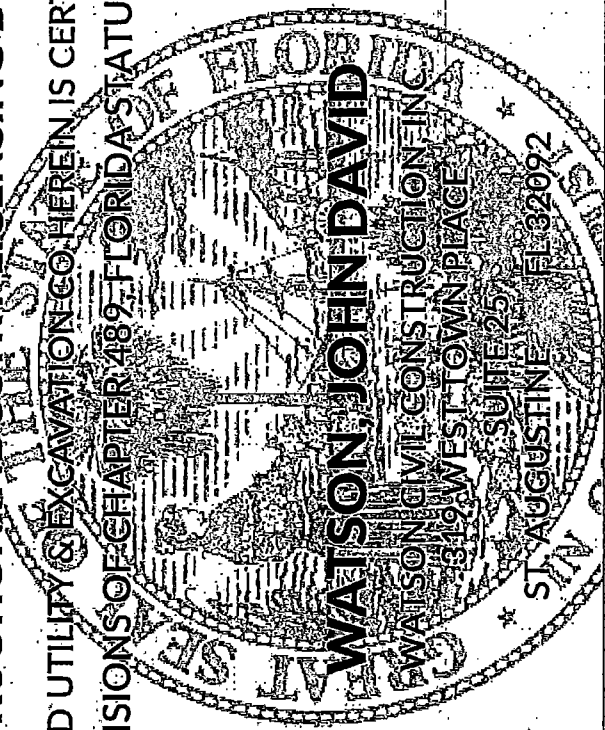

LICENSE NUMBER: CUC1224569

EXPIRATION DATE: AUGUST 31, 2024

Always verify licenses online at MyFloridaLicense.com



Do not alter this document in any form.

This is your license. It is unlawful for anyone other than the licensee to use this document.

This Receipt is issued pursuant to
County ordinance 87-36

2023/2024 ST. JOHNS COUNTY LOCAL BUSINESS TAX RECEIPT

MUST BE DISPLAYED IN A CONSPICUOUS PLACE

Account: 1065339
EXPIRES September 30, 2024

Business Type General Contractor (L)
Location 319 N Town Place # 25
St Augustine FL 32092

Business Name **Watson Civil Construction
Inc**

Owner Name Watson Civil Construction Inc

**Mailing
Address** 319 W Town Pl Ste 25
St. Augustine, FL 32092



**New Business
Transfer**

Tax	18.00
Penalty	0.00
Cost	0.00
Total	18.00

RECEIVED

JUL 24 2023

**DENNIS W. HOLLINGSWORTH
ST. JOHNS COUNTY TAX COLLECTOR**

This receipt does not constitute a franchise, an agreement, permission or authority to perform the services or operate the business described herein when a franchise, an agreement, or other county commission, state or federal permission or authority is required by county, state or federal law.

This form becomes a receipt only when validated below

Paid by receipt(s) 2022-8511894 on 07/19/23 for \$18.00

This Receipt is issued pursuant to
County ordinance 87-36.

**2023/2024 ST. JOHNS COUNTY
LOCAL BUSINESS TAX RECEIPT**

MUST BE DISPLAYED IN A CONSPICUOUS PLACE

Account 1065341
EXPIRES September 30, 2024

Business Type Underground Utilities (L)
Location 319 W Town Place # 25
St Augustine FL 32092

New Business
Transfer

Business Name **Watson Civil Construction
Inc**



Tax 18.00
Penalty 0.00
Cost 0.00
Total 18.00

RECEIVED
JUL 24 2023

Owner Name Watson Civil Construction Inc

Mailing Address 319 W Town Pl Ste 25
St. Augustine, FL 32092

**DENNIS W. HOLLINGSWORTH
ST. JOHNS COUNTY TAX COLLECTOR**

This receipt does not constitute a franchise, an agreement,
permission or authority to perform the services or operate the
business described herein when a franchise, an agreement, or
other county commission, state or federal permission or
authority is required by county, state or federal law.

This form becomes a receipt only when validated below.

Paid by receipt(s) 2022-8511894 on 07/19/23 for \$18.00



Florida Department of Transportation

RON DESANTIS
GOVERNOR

605 Suwannee Street
Tallahassee, FL 32399-0450

JARED W. PERDUE, P.E.
SECRETARY

May 04, 2023

WATSON CIVIL CONSTRUCTION, INC.
319 WEST TOWN PLACE
ST. AUGUSTINE, FLORIDA 32092

RE: CERTIFICATE OF QUALIFICATION

The Department of Transportation has qualified your company for the type of work indicated below.

FDOT APPROVED WORK CLASSES:

DRAINAGE, FLEXIBLE PAVING, GRADING, GRASSING, SEEDING AND SODDING, HOT PLANT-MIXED BITUM. COURSES, INTERMEDIATE BRIDGES, MAJOR BRIDGE - CURVED STEEL GIRDERS, MINOR BRIDGES, PORTLAND CEMENT CONCRETE ROADWAY PAVING, ROADWAY SIGNING, SIDEWALK, TRAFFIC SIGNAL, Curb & Gutter, Concrete traffic Separator, Drill Shaft, Fender Systems, Pile Driving, Retaining Walls, Rip Rap, Rubble Rip Rap, Underground Utilities (Water & Sewer) Utility Work.

Unless notified otherwise, this Certificate of Qualification will expire 6/30/2024.

In accordance with Section 337.14(4), Florida Statutes, changes to Ability Factor or Maximum Capacity Rating will not take effect until after the expiration of the current certificate of prequalification (if applicable).

In accordance with Section 337.14(1), Florida Statutes, an application for qualification must be filed within (4) months of the ending date of the applicant's audited annual financial statements.

If the company's maximum capacity has been revised, it may be accessed by logging into the Contractor Prequalification Application System via the following link:

[HTTPS://fdotwpl.dot.state.fl.us/ContractorPreQualification](https://fdotwpl.dot.state.fl.us/ContractorPreQualification)

Once logged in, select "View" for the most recently approved application, and then click the "Manage" and "Application Summary" tabs.

The company may apply for a Revised Certificate of Qualification at any time prior to the expiration date of this certificate according to Section 14-22.0041(3), Florida Administrative Code (F.A.C.), by accessing the most recently approved application as shown above and choosing "Update" instead of "View." If certification in additional classes of work is desired, documentation is needed to show that the company has performed such work.

All prequalified contractors are required by Section 14-22.006(3), F.A.C., to certify their work underway monthly in order to adjust maximum bidding capacity to available bidding capacity. You can find the link to this report at the website shown above.

Sincerely,

James E. Taylor II, Prequalification Supervisor
Contracts Administration Office

JTII:cg

Improve Safety, Enhance Mobility, Inspire Innovation

www.fdot.gov



Florida Department of Transportation

RON DESANTIS
GOVERNOR

605 Suwannee Street
Tallahassee, FL 32399-0450

JARED W. PERDUE, P.E.
SECRETARY

May 10, 2023

ACME BARRICADES LC
9800 NORMANDY BLVD
JACKSONVILLE, FLORIDA 32221

RE: CERTIFICATE OF QUALIFICATION

The Department of Transportation has qualified your company for the type of work indicated below.

FDOT APPROVED WORK CLASSES:
GUARDRAIL, PAVEMENT MARKING, ROADWAY SIGNING

Unless notified otherwise, this Certificate of Qualification will expire **6/30/2024**.

In accordance with Section 337.14(4), Florida Statutes, changes to Ability Factor or Maximum Capacity Rating will not take effect until after the expiration of the current certificate of prequalification (if applicable).

In accordance with Section 337.14(1), Florida Statutes, an application for qualification must be filed within (4) months of the ending date of the applicant's audited annual financial statements.

If the company's maximum capacity has been revised, it may be accessed by logging into the Contractor Prequalification Application System via the following link:
[HTTPS://fdotwpl.dot.state.fl.us/ContractorPreQualification](https://fdotwpl.dot.state.fl.us/ContractorPreQualification)

Once logged in, select "View" for the most recently approved application, and then click the "Manage" and "Application Summary" tabs.

The company may apply for a Revised Certificate of Qualification at any time prior to the expiration date of this certificate according to Section 14-22.0041(3), Florida Administrative Code (F.A.C.), by accessing the most recently approved application as shown above and choosing "Update" instead of "View." If certification in additional classes of work is desired, documentation is needed to show that the company has performed such work.

All prequalified contractors are required by Section 14-22.006(3), F.A.C., to certify their work underway monthly in order to adjust maximum bidding capacity to available bidding capacity. You can find the link to this report at the website shown above.

Sincerely,

James E. Taylor II, Prequalification Supervisor
Contracts Administration Office

JTII:cg



NHC

NIELSON, WOJTOWICZ, NEU & ASSOCIATES
A NIELSON HOOPER GROUP COMPANY

ACRISURE
AGENCY PARTNER

April 25, 2023

FL Department of Transportation
605 Suwannee St.
Tallahassee, FL 32399

RE: Watson Civil Construction, Inc.
Annual Prequalification

To Whom It May Concern:

This is to advise you that our office provides bid, performance, and payment bonds for **Watson Civil Construction, Inc.** The name of their surety is **Travelers Casualty and Surety Company of America**, which carries an A.M. Best Rating of **A++ XV**, and it is listed in the Department of Treasury's Federal Register.

Watson Civil Construction, Inc. is a highly valued client of our agency and the surety. We currently have an established bonding line of **\$750,000,000** and would consider larger parameters based on our client's request. We reserve the right to review final contractual documents, bond forms and obtain satisfactory evidence of funding prior to final commitment to issue bonds.

This letter is not an assumption of liability, nor is it a bid or performance and payment bond. It is issued only as a bonding reference requested by our respected client. We do not assume liability to any third party, including you, if we do not execute said bonds.

Watson Civil Construction, Inc. is an excellent contractor, and we hold them in the highest regard. We feel extremely confident in our contractor and encourage you to offer them an opportunity to execute any upcoming projects.

If you should have any questions, please do not hesitate to give me a call.

Sincerely,

Kevin R. Wojtowicz
Attorney-in-Fact
KRW/asp

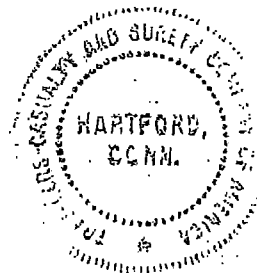



**Travelers Casualty and Surety Company of America
Travelers Casualty and Surety Company
St. Paul Fire and Marine Insurance Company
Farmington Casualty Company**

POWER OF ATTORNEY

KNOW ALL MEN BY THESE PRESENTS: That Travelers Casualty and Surety Company of America, Travelers Casualty and Surety Company, St. Paul Fire and Marine Insurance Company, and Farmington Casualty Company are corporations duly organized under the laws of the State of Connecticut (herein collectively called the "Companies"), and that the Companies do hereby make, constitute and appoint Kevin R. Wojtowicz of St. Petersburg, Florida, their true and lawful Attorney(s)-in-Fact to sign, execute, seal and acknowledge any and all bonds, recognizances, conditional undertakings and other writings obligatory in the nature thereof (including any and all consents required by the Florida Department of Transportation or the Central Florida Expressway Authority incident to the release of retained percentages and/or final estimates) on behalf of the Companies in their business of guaranteeing the fidelity of persons, guaranteeing the performance of contracts and executing or guaranteeing bonds and undertakings required or permitted in any actions or proceedings allowed by law.

IN WITNESS WHEREOF, the Companies have caused this instrument to be signed, and their corporate seals to be hereto affixed, this 21st day of April, 2021.



State of Connecticut

By: *Robert L. Raney*
Robert L. Raney, Senior Vice President

City of Hartford ss.

On this the 21st day of April, 2021, before me personally appeared Robert L. Raney, who acknowledged himself to be the Senior Vice President of each of the Companies, and that he, as such, being authorized so to do, executed the foregoing instrument for the purposes therein contained by signing on behalf of said Companies by himself as a duly authorized officer.

IN WITNESS WHEREOF, I hereunto set my hand and official seal.

My Commission expires the 30th day of June, 2026



Anna P. Nowik
Anna P. Nowik, Notary Public

This Power of Attorney is granted under and by the authority of the following resolutions adopted by the Boards of Directors of each of the Companies, which resolutions are now in full force and effect, reading as follows:

RESOLVED, that the Chairman, the President, any Vice Chairman, any Executive Vice President, any Senior Vice President, any Vice President, any Second Vice President, the Treasurer, any Assistant Treasurer, the Corporate Secretary or any Assistant Secretary may appoint Attorneys-in-Fact and Agents to act for and on behalf of the Company and may give such appointee such authority as his or her certificate of authority may prescribe to sign with the Company's name and seal with the Company's seal bonds, recognizances, contracts of indemnity, and other writings obligatory in the nature of a bond, recognizance, or conditional undertaking, and any of said officers or the Board of Directors at any time may remove any such appointee and revoke the power given him or her; and it is

FURTHER RESOLVED, that the Chairman, the President, any Vice Chairman, any Executive Vice President, any Senior Vice President or any Vice President may delegate all or any part of the foregoing authority to one or more officers or employees of this Company, provided that each such delegation is in writing and a copy thereof is filed in the office of the Secretary; and it is

FURTHER RESOLVED, that any bond, recognizance, contract of indemnity, or writing obligatory in the nature of a bond, recognizance, or conditional undertaking shall be valid and binding upon the Company when (a) signed by the President, any Vice Chairman, any Executive Vice President, any Senior Vice President or any Vice President, any Second Vice President, the Treasurer, any Assistant Treasurer, the Corporate Secretary or any Assistant Secretary and duly attested and sealed with the Company's seal by a Secretary or Assistant Secretary; or (b) duly executed (under seal, if required) by one or more Attorneys-in-Fact and Agents pursuant to the power prescribed in his or her certificate or their certificates of authority or by one or more Company officers pursuant to a written delegation of authority; and it is

FURTHER RESOLVED, that the signature of each of the following officers: President, any Executive Vice President, any Senior Vice President, any Vice President, any Assistant Vice President, any Secretary, any Assistant Secretary, and the seal of the Company may be affixed by facsimile to any Power of Attorney or to any certificate relating thereto appointing Resident Vice Presidents, Resident Assistant Secretaries or Attorneys-in-Fact for purposes only of executing and attesting bonds and undertakings and other writings obligatory in the nature thereof, and any such Power of Attorney or certificate bearing such facsimile signature or facsimile seal shall be valid and binding upon the Company and any such power so executed and certified by such facsimile signature and facsimile seal shall be valid and binding on the Company in the future with respect to any bond or understanding to which it is attached.

I, Kevin E. Hughes, the undersigned, Assistant Secretary of each of the Companies, do hereby certify that the above and foregoing is a true and correct copy of the Power of Attorney executed by said Companies, which remains in full force and effect.

Dated this 25th day of April, 2023



Kevin E. Hughes
Kevin E. Hughes, Assistant Secretary

To verify the authenticity of this Power of Attorney, please call us at 1-800-421-3880.
Please refer to the above-named Attorney(s)-in-Fact and the details of the bond to which this Power of Attorney is attached.

Request for Taxpayer Identification Number and Certification

Give Form to the
 requester. Do not
 send to the IRS.

▶ Go to www.irs.gov/FormW9 for instructions and the latest information.

Print or type.
 See Specific instructions on page 3.

1 Name (as shown on your income tax return). Name is required on this line; do not leave this line blank. Watson Civil Construction, Inc.	
2 Business name/disregarded entity name, if different from above	
3 Check appropriate box for federal tax classification of the person whose name is entered on line 1. Check only one of the following seven boxes. <input type="checkbox"/> Individual/sole proprietor or single-member LLC <input type="checkbox"/> Limited liability company. Enter the tax classification (C=C corporation, S=S corporation, P=Partnership) ▶ _____ Note: Check the appropriate box in the line above for the tax classification of the single-member owner. Do not check LLC if the LLC is classified as a single-member LLC that is disregarded from the owner unless the owner of the LLC is another LLC that is not disregarded from the owner for U.S. federal tax purposes. Otherwise, a single-member LLC that is disregarded from the owner should check the appropriate box for the tax classification of its owner. <input type="checkbox"/> Other (see instructions) ▶ _____ <input type="checkbox"/> C Corporation <input checked="" type="checkbox"/> S Corporation <input type="checkbox"/> Partnership <input type="checkbox"/> Trust/estate	4 Exemptions (codes apply only to certain entities, not individuals; see instructions on page 3): Exempt payee code (if any) _____ Exemption from FATCA reporting code (if any) _____ (Applies to accounts maintained outside the U.S.)
5 Address (number, street, and apt. or suite no.) See instructions. 319 West Town Place, Suite 25	Requester's name and address (optional)
6 City, state, and ZIP code St. Augustine, FL 32092	
7 List account number(s) here (optional)	

Part I Taxpayer Identification Number (TIN)

Enter your TIN in the appropriate box. The TIN provided must match the name given on line 1 to avoid backup withholding. For individuals, this is generally your social security number (SSN). However, for a resident alien, sole proprietor, or disregarded entity, see the instructions for Part I, later. For other entities, it is your employer identification number (EIN). If you do not have a number, see *How to get a TIN*, later.

Note: If the account is in more than one name, see the instructions for line 1. Also see *What Name and Number To Give the Requester* for guidelines on whose number to enter.

Social security number									
<table style="width: 100%; border-collapse: collapse;"> <tr> <td style="width: 25%; border: 1px solid black; height: 20px;"></td> <td style="width: 25%; border: 1px solid black; height: 20px;"></td> <td style="width: 25%; border: 1px solid black; height: 20px;"></td> <td style="width: 25%; border: 1px solid black; height: 20px;"></td> </tr> </table>					<table style="width: 100%; border-collapse: collapse;"> <tr> <td style="width: 25%; border: 1px solid black; height: 20px;"></td> <td style="width: 25%; border: 1px solid black; height: 20px;"></td> <td style="width: 25%; border: 1px solid black; height: 20px;"></td> <td style="width: 25%; border: 1px solid black; height: 20px;"></td> </tr> </table>				
OR									
Employer identification number									
<table style="width: 100%; border-collapse: collapse;"> <tr> <td style="width: 25%; border: 1px solid black; text-align: center;">4</td> <td style="width: 25%; border: 1px solid black; text-align: center;">6</td> <td style="width: 25%; border: 1px solid black; text-align: center;">-</td> <td style="width: 25%; border: 1px solid black; text-align: center;">5</td> </tr> <tr> <td style="width: 25%; border: 1px solid black; text-align: center;">6</td> <td style="width: 25%; border: 1px solid black; text-align: center;">3</td> <td style="width: 25%; border: 1px solid black; text-align: center;">9</td> <td style="width: 25%; border: 1px solid black; text-align: center;">8</td> </tr> </table>	4	6	-	5	6	3	9	8	
4	6	-	5						
6	3	9	8						

Part II Certification

Under penalties of perjury, I certify that:

- The number shown on this form is my correct taxpayer identification number (or I am waiting for a number to be issued to me); and
- I am not subject to backup withholding because: (a) I am exempt from backup withholding, or (b) I have not been notified by the Internal Revenue Service (IRS) that I am subject to backup withholding as a result of a failure to report all interest or dividends, or (c) the IRS has notified me that I am no longer subject to backup withholding; and
- I am a U.S. citizen or other U.S. person (defined below); and
- The FATCA code(s) entered on this form (if any) indicating that I am exempt from FATCA reporting is correct.

Certification instructions. You must cross out item 2 above if you have been notified by the IRS that you are currently subject to backup withholding because you have failed to report all interest and dividends on your tax return. For real estate transactions, item 2 does not apply. For mortgage interest paid, acquisition or abandonment of secured property, cancellation of debt, contributions to an individual retirement arrangement (IRA), and generally, payments other than interest and dividends, you are not required to sign the certification, but you must provide your correct TIN. See the instructions for Part II, later.

Sign Here	Signature of U.S. person ▶ <i>Michelle D. Hubert</i>	Date ▶ <i>2/10/2023</i>
------------------	------------------------------------------------------	-------------------------

General Instructions

Section references are to the Internal Revenue Code unless otherwise noted.

Future developments. For the latest information about developments related to Form W-9 and its instructions, such as legislation enacted after they were published, go to www.irs.gov/FormW9.

Purpose of Form

An individual or entity (Form W-9 requester) who is required to file an information return with the IRS must obtain your correct taxpayer identification number (TIN) which may be your social security number (SSN), individual taxpayer identification number (ITIN), adoption taxpayer identification number (ATIN), or employer identification number (EIN), to report on an information return the amount paid to you, or other amount reportable on an information return. Examples of information returns include, but are not limited to, the following.

- Form 1099-INT (interest earned or paid)

- Form 1099-DIV (dividends, including those from stocks or mutual funds)
- Form 1099-MISC (various types of income, prizes, awards, or gross proceeds)
- Form 1099-B (stock or mutual fund sales and certain other transactions by brokers)
- Form 1099-S (proceeds from real estate transactions)
- Form 1099-K (merchant card and third party network transactions)
- Form 1098 (home mortgage interest), 1098-E (student loan interest), 1098-T (tuition)
- Form 1099-C (canceled debt)
- Form 1099-A (acquisition or abandonment of secured property)

Use Form W-9 only if you are a U.S. person (including a resident alien), to provide your correct TIN.

If you do not return Form W-9 to the requester with a TIN, you might be subject to backup withholding. See *What is backup withholding*, later.

2023 FLORIDA PROFIT CORPORATION ANNUAL REPORT

DOCUMENT# P14000038801

Entity Name: WATSON CIVIL CONSTRUCTION, INC.

Current Principal Place of Business:

319 WEST TOWN PLACE
SUITE 25
ST AUGUSTINE, FL 32092

Current Mailing Address:

319 WEST TOWN PLACE
SUITE 25
ST AUGUSTINE, FL 32092 US

FEI Number: 46-5639198

Certificate of Status Desired: No

Name and Address of Current Registered Agent:

VEZINA, W. ROBERT III
413 EAST PARK AVENUE
TALL, FL 32301 US

The above named entity submits this statement for the purpose of changing its registered office or registered agent, or both, in the State of Florida.

SIGNATURE:

Electronic Signature of Registered Agent

Date

Officer/Director Detail :

Title GEO, PRESIDENT, TREASURER
Name WATSON, JOHN D
Address 319 WEST TOWN PLACE
SUITE 25
City-State-Zip: ST AUGUSTINE FL 32092

Title VP
Name PEPLINSKI, CRAIG J
Address 319 WEST TOWN PLACE
SUITE 25
City-State-Zip: ST AUGUSTINE FL 32092

Title SECRETARY
Name HUBERT, MICHELE D
Address 319 WEST TOWN PLACE
SUITE 25
City-State-Zip: ST AUGUSTINE FL 32092

Title ASST. SECRETARY
Name DE LA SERNA, FRANKLIN T
Address 319 WEST TOWN PLACE
SUITE 25
City-State-Zip: ST AUGUSTINE FL 32092

Title SECRETARY
Name HODGINS, WESLEY
Address 319 WEST TOWN PLACE
SUITE 25
City-State-Zip: ST AUGUSTINE FL 32092

Title OFFICER
Name KEEN, AARON
Address 319 WEST TOWN PLACE
SUITE 25
City-State-Zip: ST AUGUSTINE FL 32092

I hereby certify that the information indicated on this report or supplemental report is true and accurate and that my electronic signature shall have the same legal effect as if made under oath; that I am an officer or director of the corporation or the receiver or trustee empowered to execute this report as required by Chapter 607, Florida Statutes; and that my name appears above, or on an attachment with all other like empowered.

SIGNATURE: JOHN WATSON

PRESIDENT

02/28/2023

Electronic Signature of Signing Officer/Director Detail

Date

WATSON CIVIL

CONSTRUCTION

WHEREAS, the Corporation desires to grant signing and authority to certain person(s) described hereunder.

RESOLVED, that the Principals of Watson Civil Construction, Inc. are hereby authorized and approved to grant signing and authority to conduct business to any one of the following persons:

John D. Watson – President

Craig Peplinski – Vice President

Aaron Keen – Officer

Franklin de la Serna – Assistant Secretary

The foregoing signing and authority granted shall include the execution of contracts and other instruments entered into by this Corporation.

The undersigned hereby certifies that he is the duly elected and qualified Secretary and the custodian of the books and records and seal of Watson Civil Construction, Inc. a corporation duly formed pursuant to the laws of the state of Florida and that the foregoing is a true record of a resolution duly adopted at a meeting of the Principals of Watson Civil Construction, Inc. and that said meeting was held in accordance with state law and the Bylaws of the above-named Corporation on April 3, 2023, and that said resolution is now in full force and effect without modification or rescission.

IN WITNESS WHEREOF, I have executed my name as Secretary of the above-named Corporation this 3 April 2023.

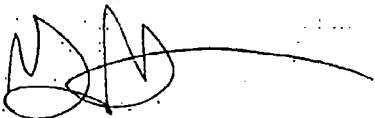

Wesley Hodgins

Secretary – Watson Civil Construction, Inc.

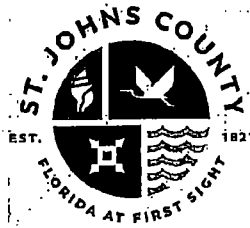

ADDENDUM #1

September 28, 2023

To: Prospective Bidders
From: St. Johns County Purchasing Division
Subject: Bid No: 23-94 CR 210 Widening from Trinity Way to Beachwalk Boulevard

This Addendum #1 is issued for further Bidders' information, and is hereby incorporated into the BID Documents. Each Bidder must incorporate any and all revisions, clarifications, and/or supplemental information provided in all issued addenda with the submitted Bid. Bidders must submit a copy of each signed addendum with their Bid as provided in the Bid Documents.

Revisions/Clarifications:

The County provides the following revisions and/or clarifications to be incorporated into the Bid Documents:

1. Replace Table of Contents page 2 of the Bid Document and replace with same page contained in this Addendum.
2. Remove the Official County Bid Form pages 18 and 19 and replace with the same pages contained in this Addendum.
3. Remove Attachment "P" – Schedule of Values – Eighteen (18) Months Completion Time and replace with Revised Attachment "P" – Revised Schedule of Values – Eighteen (18) Months Completion Time contained in this Addendum.
4. Remove Attachment "Q" – Schedule of Values – Fifteen (15) Months Completion Time.
5. Replace Exhibit "A" CR 210 Widening Construction Plans – Dated February 23, 2023 with Revised Exhibit "A" CR 210 Widening Construction Plans – Dated September 2023.
6. Computer Aided Design files have been placed on the St. Johns County Public Works website and can be accessed by clicking the link below and entering the User Name and Password listed below:

Link: [St. Johns County Public Works Website](#)

User Name: Pubworksanon

Password: sjcpubworks

All files can be accessed in the **CR 210 Widening (Twin Creeks)** file folder.

7. Due to the scope and size of this project, the Bid Opening initially scheduled for Wednesday, 2:00 PM on October 11, 2023 is hereby changed to Wednesday, 2:00 PM on October 18, 2023.



Questions/Answers:

The County provides the following answers to the questions submitted below:

1. Following the installation & inspection criteria set forth in FDOT's "Standard Specifications for Road and Bridge Construction", may FDOT approved Class II Polypropylene Pipe be used on this project as an alternate storm drainage material?

Answer: No. Per plans sheet 18, note 27, all storm pipe shall be Reinforced Concrete Pipe.

2. Will bidder be required to be either FL CGC or FL CUC, or will bidder be required to hold both certifications?

Answer: Contractor must have either or FL CGC or FL CUC certifications.

3. What warranty period will be required? SJC is typically 26 months, FDOT is 24 months, some projects 12 months.

Answer: Contractor warrants all materials, equipment and labor it furnishes or performs under this Contract against all defects in design, materials and workmanship for a period of one year (or the period of time in any guarantee or warranty provided by any manufacturer or supplier of equipment or materials incorporated into the Work, whichever is later) from and after the date of Final Completion.

4. Please define the funding source for the project.

Answer: County Capital Funds

5. Who will be responsible for utility relocation, including any required coordination, design, permits or fees?

Answer: Utility relocations will be completed by the responsible utility company. Coordination between the contractor and the utility companies will be necessary. Any design work for relocations will be completed by the responsible utility company. No requirements for permitting are expected or currently required.

6. I notice signal plans within this project, I have also noticed that a previous project was out for bid involving the same signal location, how is this going to be coordinated?

Answer: The signal plans for this this project is being completed under a separate contract (Bid No. 23-84). The Signal Project Contractor will be invited to attend pre-construction and progress meetings to aid in coordination between these two projects.

7. On sheet 25 showing installation of 54" pipe to a pond? Sheet 53 shows existing 42" to remain which is correct?

Answer: The 42" is to remain with no 54" to be constructed. (Please see Exhibit "A" Sept. 2023)

8. All typical sections show SP-9.5 for final lift of asphalt. Attachment "P" of the bidding documents shows FC-9.5, TL-B, PG 76-22 (Line 13). Please advise correct mix type?

Answer: Per County Standard, SP 9.5 is acceptable asphalt. (Please see Revised Attachment "P".)



9. Current FDOT Specifications govern per contract plans. Specially, please advise if section 9-2.1.2 Bituminous Material is applicable to this contract?
Answer: FDOT Design Build Specifications Div. 1 – Sect. 9-2.1.2 is not applicable for this project.
10. Sheet 25 calls out to construct 324 LF of 54" Pipe from Structure S-730A. Sheet 53 calls out Structure S-730B in the location of Structure S-730A and shows Existing 42" Pipe (To Remain). Is Structure S-730B supposed to be Structure S-730A and is the 42" Pipe to remain or is the 54" Pipe to be constructed? 54" Pipe is not included in the bid form.
Answer: The 42" is to remain with no 54" to be constructed. Structure reference should be 730A. Disregard 54" pipe. (Please see Exhibit "A" Sept. 2023)
11. Sheet 22 calls out to construct Pedestrian Railing on both sides of the roadway. Pedestrian Railing is not included in the bid form. Is the Pedestrian Railing to be constructed and what type of railing should be installed?
Answer: Proposed railing is to be Aluminum Ped/Bike Railing per FDOT Index 515-062. (Please see Exhibit "A" Sept. 2023)
12. Sheet 135 shows a Tabulation of Signal Quantities. The Signal Quantities are not included in the bid form. Will a new bid form be issued to include the Signal Quantities?
Answer: Please refer to question #6.
13. Sheet 53 calls out CS-1A Control Structure to be modified. What bid item does this modification fall under? Should this modification be added to the bid form?
Answer: Template is not all inclusive and can be modified based on contractors bid estimate. (Please see Revised Attachment "P".)
14. Can the bid form be provided in Excel format?
Answer: No.
15. It is stated that bidders must be licensed in Pavement Markings. Can the Pavement Markings be performed by a subcontractor?
Answer: Yes. Contractors and Sub-Contractors must be appropriately licensed for the work being performed.
16. What, if any, is the retainage for the project?
Answer: Retainage is at 5% until final acceptance of all work.
17. Will all of the mobilization be paid at the beginning of the project?
Answer: Mobilization payout will be dependent upon contractor invoice submittals.
18. How will rain days be handled during construction?
Answer: Utilizing appropriate Storm Water Pollution Prevention Plan (SWPPP) reports/documentation, weather event days will be reviewed for granting additional time for final completion.

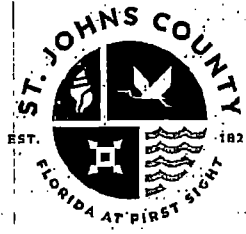

19. What holidays are observed throughout the year during construction?

Answer: The following holidays are recognized St. Johns County: New Year's, Martin Luther King Jr. Day, President's Day, Good Friday, Memorial Day, Independence Day, Labor Day, Veteran's Day, Thanksgiving (2 days) and Christmas (2 days).

20. How will fuel be handled throughout construction? FDOT fuel standards?

Answer: The County does not utilize fuel standards. All fuel concerns should be built into the bid, as this project will be a lump sum project.

21. Is any builders risk required for the bid?

Answer: No.

22. On the Schedule of Values, there are no Pay Items for the Maintenance of Traffic. Please provide applicable bid items and quantities for Commercial Material for Driveway Maintenance, Pedestrian or Bicycle Special Detour, Traffic Control Officer, Work Zone Signs, Business Signs, Arrow Board, Temporary Raised Pavement Markers, Portable Changeable Message Sign, Temporary Signalization and Maintenance, Temporary Traffic Detection and Maintenance, Type III Barricade, Portable Regulatory Sign, Painted Pavement Markings and Temporary Striping.

Answer: Maintenance of Traffic has been added. (Please see Revised Attachment "P".)

23. Will temporary pavement, temporary drainage, temporary embankment, temporary striping, temporary signs and temporary grassing be required to safely facilitate the movement of traffic across the construction phasing limits? Will you update the MOT plans to show the above items?

Answer: Please refer to question #22.

24. The are no Schedule of Values for the Signalization. Can you please provide?

Answer: Please refer to question #6.

SUBMITTAL DEADLINE FOR BIDS IS HEREBY CHANGED TO, WEDNESDAY, OCTOBER 18, 2023 AT 2:00 PM

Bidder Acknowledgment:

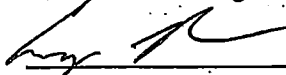

Signature
Craig Peplinski, Vice President
Printed Name/Title
Watson Civil Construction, Inc.
Respondent Company Name

Attachments: None

END OF ADDENDUM NO. #1

Purchasing Division | 500 San Sebastian View, St. Augustine, FL 32084 | 904.209.0150 | sjcfl.us

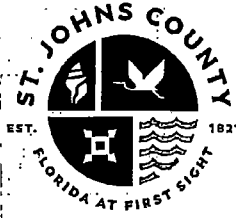

ADDENDUM #2

October 12, 2023

To: Prospective Bidders
From: St. Johns County Purchasing Division
Subject: Bid No: 23-94 CR 210 Widening from Trinity Way to Beachwalk Boulevard

This Addendum #2 is issued for further Bidders' information, and is hereby incorporated into the Bid Documents. Each Bidder must incorporate any and all revisions, clarifications, and/or supplemental information provided in all issued addenda with the submitted Bid. Bidders must submit a copy of each signed addendum with their Bid as provided in the Bid Documents.

Revisions/Clarifications:

The County provides the following revisions and/or clarifications to be incorporated into the Bid Documents:

1. Replace Table of Contents page 2 of the Bid Document and replace with same page contained in this Addendum.
2. Remove the Official County Bid Form pages 18 and 19 and replace with the same pages contained in this Addendum.
3. Remove Attachment "P" – Schedule of Values – Eighteen (18) Months Completion Time and replace with Revised Attachment "P" – Addendum #2 Revised Schedule of Values – Eighteen (18) Months Completion Time contained in this Addendum.
4. Add Exhibit "D" – Temporary Traffic Control Plan contained in this Addendum.
5. Add Exhibit "E" – CR 210 Signal Plans for Coordination and Information contained in this Addendum.
6. Due to the release of Addendum #2, the Bid Opening initially scheduled for Wednesday, 2:00 PM on October 18, 2023 (EDST) is hereby changed to Wednesday, 2:00 PM on October 25, 2023 (EDST).

SUBMITTAL DEADLINE FOR BIDS IS HEREBY CHANGED TO, WEDNESDAY, OCTOBER 25, 2023 AT 2:00 PM (EDST)

Bidder Acknowledgment:



Signature

Craig Replinski, UP
Printed Name/Title

Watson Civil Construction, Inc.
Respondent Company Name

END OF ADDENDUM NO. #2

Purchasing Department | 500 San Sebastian View, St. Augustine, FL 32084 | 904.209.0150 | sjcfl.us

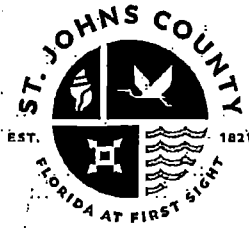

ADDENDUM #3

October 19, 2023

To: Prospective Bidders
From: St. Johns County Purchasing Division
Subject: Bid No: 23-94 CR 210 Widening from Trinity Way to Beachwalk Boulevard

This Addendum #3 is issued for further Bidders' information, and is hereby incorporated into the BID Documents. Each Bidder must incorporate any and all revisions, clarifications, and/or supplemental information provided in all issued addenda with the submitted Bid. Bidders must submit a copy of each signed addendum with their Bid as provided in the Bid Documents.

Revisions/Clarifications:

The County provides the following revisions and/or clarifications to be incorporated into the Bid Documents:

1. Replace Table of Contents page 2 of the Bid Document and replace with same page contained in this Addendum.
2. Remove Attachment "P" – Addendum #2 Revised Schedule of Values – Eighteen (18) Months Completion Time and replace with Revised Attachment "P" – Addendum #3 Revised Schedule of Values – Eighteen (18) Months Completion Time contained in this Addendum.

SUBMITTAL DEADLINE FOR BIDS REMAINS WEDNESDAY, OCTOBER 25, 2023 AT 2:00 PM (EDST)

Bidder Acknowledgment:



Signature

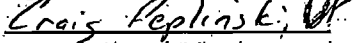

Printed Name/Title

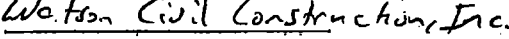

Respondent Company Name

END OF ADDENDUM NO. #3



ADDENDUM #4

October 20, 2023

To: Prospective Bidders
From: St. Johns County Purchasing Division
Subject: Bid No: 23-94 CR 210 Widening from Trinity Way to Beachwalk Boulevard

This Addendum #4 is issued for further Bidders' information, and is hereby incorporated into the Bid Documents. Each Bidder must incorporate any and all revisions, clarifications, and/or supplemental information provided in all issued addenda with the submitted Bid. Bidders must submit a copy of each signed addendum with their Bid as provided in the Bid Documents.

Revisions/Clarifications:

The County provides the following revisions and/or clarifications to be incorporated into the Bid Documents:

1. Replace Table of Contents page 2 of the Bid Document and replace with same page contained in this Addendum.
2. Remove Attachment "P" – Addendum #3 Revised Schedule of Values – Eighteen (18) Months Completion Time and replace with Revised Attachment "P" – Addendum #4 Revised Schedule of Values – Eighteen (18) Months Completion Time contained in this Addendum.

SUBMITTAL DEADLINE FOR BIDS REMAINS WEDNESDAY, OCTOBER 25, 2023 AT 2:00 PM (EDST)

Bidder Acknowledgment:

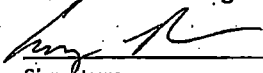
Signature
Craig Replinski, VP
Printed Name/Title
Watson Civil Construction, Inc.
Respondent Company Name

END OF ADDENDUM NO. #4



Contractor Pre-Qualification (CPQ)



Prequalified Contractors Listing

10/25/2023 10:12:20 AM EST

[Return to Inquiry Menu](#)

Contractor with Name KUDZUE 3 TRUCKING INC.
1-1 of 1 contractors

[Printer Friendly Version](#)

VENDOR NAME	HOME OFFICE ADDRESS	BIDDING OFFICE ADDRESS
KUDZUE 3 TRUCKING INC. F202325377004 EXPIRES: 6/30/2024	P.O. BOX 1799 YULEE, FL 32041 (904)388-7838	P.O. BOX 1799 YULEE, FL 32041 (904)388-7838
WORK CLASSES		
FLEXIBLE PAVING	HOT PLANT-MIXED BITUM. COURSES	



FLORIDA DEPARTMENT OF TRANSPORTATION
 Report Technical Problems to the Service Desk @ 1-866-955-4357 or email: [Service Desk](#)
 Send Prequalification Questions or Comments to [Contracts Administration Office](#)
[Internet Privacy Policy, Disclaimers & Credits](#)





[Department of State](#) / [Division of Corporations](#) / [Search Records](#) / [Search by Entity Name](#) /

Detail by Entity Name

Florida Profit Corporation
KUDZUE 3 TRUCKING INC.

Filing Information

Document Number P05000025648
FEI/EIN Number 20-2325377
Date Filed 02/17/2005
State FL
Status ACTIVE
Last Event AMENDMENT
Event Date Filed 08/30/2010
Event Effective Date NONE

Principal Address

16500 OAKHILL ROAD
HILLIARD, FL 32046

Changed: 04/12/2012

Mailing Address

P.O. BOX 1799
YULEE, FL 32041

Changed: 02/06/2008

Registered Agent Name & Address

MALOY, THOMAS R
16500 OAKHILL ROAD
HILLIARD, FL 32046

Officer/Director Detail

Name & Address

Title PRES

MALOY, THOMAS R
16500 OAKHILL ROAD
HILLIARD, FL 32046

Annual Reports

Report Year	Filed Date
-------------	------------

2021 01/28/2021
2022 01/17/2022
2023 03/28/2023

Document Images

03/28/2023 – ANNUAL REPORT	View image in PDF format
01/17/2022 – ANNUAL REPORT	View image in PDF format
01/28/2021 – ANNUAL REPORT	View image in PDF format
05/15/2020 – ANNUAL REPORT	View image in PDF format
03/13/2019 – ANNUAL REPORT	View image in PDF format
01/29/2018 – ANNUAL REPORT	View image in PDF format
02/28/2017 – ANNUAL REPORT	View image in PDF format
03/01/2016 – ANNUAL REPORT	View image in PDF format
02/03/2015 – ANNUAL REPORT	View image in PDF format
02/28/2014 – ANNUAL REPORT	View image in PDF format
03/26/2013 – ANNUAL REPORT	View image in PDF format
04/12/2012 – ANNUAL REPORT	View image in PDF format
02/25/2011 – ANNUAL REPORT	View image in PDF format
02/24/2011 – EMAIL	View image in PDF format
08/30/2010 – Amendment	View image in PDF format
01/27/2010 – ANNUAL REPORT	View image in PDF format
01/26/2009 – ANNUAL REPORT	View image in PDF format
02/06/2008 – ANNUAL REPORT	View image in PDF format
04/06/2007 – ANNUAL REPORT	View image in PDF format
07/17/2006 – ANNUAL REPORT	View image in PDF format
10/06/2005 – Name Change	View image in PDF format
02/17/2005 – Domestic Profit	View image in PDF format



Department of State / Division of Corporations / Search Records / Search by Entity Name /

Detail by Entity Name

Florida Profit Corporation
CURB SYSTEMS OF NE FL AT ST. AUGUSTINE, INC.

Filing Information

Document Number P07000134861
FEI/EIN Number 26-1628947
Date Filed 12/27/2007
Effective Date 01/01/2008
State FL
Status ACTIVE

Principal Address

101 CANOVA COURT
ST. AUGUSTINE, FL 32086

Changed: 04/03/2012

Mailing Address

101 CANOVA COURT
ST. AUGUSTINE, FL 32086

Changed: 04/03/2012

Registered Agent Name & Address

ALLIGOOD, GARY L
101 CANOVA COURT
ST. AUGUSTINE, FL 32086

Address Changed: 04/03/2012

Officer/Director Detail

Name & Address

Title CEO

ALLIGOOD, GARY L
101 CANOVA COURT
ST. AUGUSTINE, FL 32086

Title VP

ALLIGOOD, JUDY S
101 CANOVA COURT
ST. AUGUSTINE, FL 32086

Title President

Johnson, Darren Lamar
101 Canova Court
St. Augustine, FL 32086

Annual Reports

Report Year	Filed Date
2021	02/04/2021
2022	02/14/2022
2023	04/05/2023

Document Images

<u>04/05/2023 – ANNUAL REPORT</u>	View image in PDF format
<u>02/14/2022 – ANNUAL REPORT</u>	View image in PDF format
<u>02/04/2021 – ANNUAL REPORT</u>	View image in PDF format
<u>01/20/2020 – ANNUAL REPORT</u>	View image in PDF format
<u>02/09/2019 – ANNUAL REPORT</u>	View image in PDF format
<u>01/12/2018 – ANNUAL REPORT</u>	View image in PDF format
<u>01/12/2017 – ANNUAL REPORT</u>	View image in PDF format
<u>01/25/2016 – ANNUAL REPORT</u>	View image in PDF format
<u>03/03/2015 – ANNUAL REPORT</u>	View image in PDF format
<u>02/27/2014 – ANNUAL REPORT</u>	View image in PDF format
<u>01/24/2013 – ANNUAL REPORT</u>	View image in PDF format
<u>04/03/2012 – ANNUAL REPORT</u>	View image in PDF format
<u>01/14/2011 – ANNUAL REPORT</u>	View image in PDF format
<u>01/11/2010 – ANNUAL REPORT</u>	View image in PDF format
<u>01/19/2009 – ANNUAL REPORT</u>	View image in PDF format
<u>12/27/2007 – Domestic Profit</u>	View image in PDF format



Department of State / Division of Corporations / Search Records / Search by Entity Name /

Detail by Entity Name

Florida Profit Corporation
BELCORP., INC.

Filing Information

Document Number J44217
FEI/EIN Number 59-2738886
Date Filed 11/25/1986
Effective Date 11/20/1986
State FL
Status ACTIVE
Last Event AMENDMENT
Event Date Filed 03/06/2002
Event Effective Date NONE

Principal Address

11530 PHILIPS HWY
JACKSONVILLE, FL 32256

Changed: 01/26/2022

Mailing Address

11530 PHILIPS HWY
JACKSONVILLE, FL 32256

Changed: 01/26/2022

Registered Agent Name & Address

Bell, William T, Jr.
6407 Jack Wright Island Rd
St Augustine, FL 32092

Name Changed: 02/15/2017

Address Changed: 04/09/2020

Officer/Director Detail

Name & Address

Title President

Bell, William T, Jr.
6407 Jack Wright Island Rd
St Augustine, FL 32092

Annual Reports

Report Year	Filed Date
2021	02/01/2021
2022	01/26/2022
2023	04/05/2023

Document Images

04/05/2023 -- ANNUAL REPORT	View image in PDF format
01/26/2022 -- ANNUAL REPORT	View image in PDF format
02/01/2021 -- ANNUAL REPORT	View image in PDF format
04/09/2020 -- ANNUAL REPORT	View image in PDF format
02/14/2019 -- ANNUAL REPORT	View image in PDF format
02/06/2018 -- ANNUAL REPORT	View image in PDF format
02/15/2017 -- ANNUAL REPORT	View image in PDF format
03/07/2016 -- ANNUAL REPORT	View image in PDF format
01/13/2015 -- ANNUAL REPORT	View image in PDF format
01/21/2014 -- ANNUAL REPORT	View image in PDF format
03/21/2013 -- ANNUAL REPORT	View image in PDF format
02/27/2012 -- ANNUAL REPORT	View image in PDF format
03/14/2011 -- ANNUAL REPORT	View image in PDF format
04/06/2010 -- ANNUAL REPORT	View image in PDF format
04/29/2009 -- ANNUAL REPORT	View image in PDF format
03/24/2008 -- ANNUAL REPORT	View image in PDF format
02/26/2007 -- ANNUAL REPORT	View image in PDF format
05/01/2006 -- ANNUAL REPORT	View image in PDF format
02/21/2005 -- ANNUAL REPORT	View image in PDF format
04/19/2004 -- ANNUAL REPORT	View image in PDF format
04/17/2003 -- ANNUAL REPORT	View image in PDF format
04/22/2002 -- ANNUAL REPORT	View image in PDF format
03/06/2002 -- Amendment	View image in PDF format
04/17/2001 -- ANNUAL REPORT	View image in PDF format
04/21/2000 -- ANNUAL REPORT	View image in PDF format
04/20/1999 -- ANNUAL REPORT	View image in PDF format
04/08/1998 -- ANNUAL REPORT	View image in PDF format
03/19/1997 -- ANNUAL REPORT	View image in PDF format
03/20/1996 -- ANNUAL REPORT	View image in PDF format



Department of State / Division of Corporations / Search Records / Search by Entity Name /

Detail by Entity Name

Florida Limited Liability Company
ACME BARRICADES, L.C.

Filing Information

Document Number	L98000002616
FEI/EIN Number	59-3541899
Date Filed	11/09/1998
State	FL
Status	ACTIVE
Last Event	REINSTATEMENT
Event Date Filed	10/04/2010

Principal Address

9800 NORMANDY BLVD
JACKSONVILLE, FL 32221

Changed: 05/01/2006

Mailing Address

9800 NORMANDY BLVD
JACKSONVILLE, FL 32221

Changed: 04/29/2005

Registered Agent Name & Address

CUMMINGS, CHRISTIAN
9800 NORMANDY BLVD
JACKSONVILLE, FL 32221

Name Changed: 04/24/2009

Address Changed: 04/29/2005

Authorized Person(s) Detail

Name & Address

Title MGR

CUMMINGS, CHRISTIAN
9800 NORMANDY BLVD
JACKSONVILLE, FL 32221

Title MGR

ACME HOLDINGS
9995 GATE PARKWAY, STE. 150
JACKSONVILLE, FL 32246

Title MGR

RLS GROUP 1, LTD
121 W. FORSYTH STREET, STE. 810
JACKSONVILLE, FL 32202

Annual Reports

Report Year	Filed Date
2021	03/08/2021
2022	03/07/2022
2023	04/17/2023

Document Images

<u>04/17/2023 – ANNUAL REPORT</u>	View image in PDF format
<u>03/07/2022 – ANNUAL REPORT</u>	View image in PDF format
<u>03/08/2021 – ANNUAL REPORT</u>	View image in PDF format
<u>02/03/2020 – ANNUAL REPORT</u>	View image in PDF format
<u>01/09/2019 – ANNUAL REPORT</u>	View image in PDF format
<u>01/31/2018 – ANNUAL REPORT</u>	View image in PDF format
<u>03/03/2017 – ANNUAL REPORT</u>	View image in PDF format
<u>04/06/2016 – ANNUAL REPORT</u>	View image in PDF format
<u>03/10/2015 – ANNUAL REPORT</u>	View image in PDF format
<u>03/14/2014 – ANNUAL REPORT</u>	View image in PDF format
<u>03/01/2013 – ANNUAL REPORT</u>	View image in PDF format
<u>01/05/2012 – ANNUAL REPORT</u>	View image in PDF format
<u>01/05/2011 – ANNUAL REPORT</u>	View image in PDF format
<u>10/04/2010 – REINSTATEMENT</u>	View image in PDF format
<u>04/24/2009 – ANNUAL REPORT</u>	View image in PDF format
<u>03/20/2008 – ANNUAL REPORT</u>	View image in PDF format
<u>04/09/2007 – ANNUAL REPORT</u>	View image in PDF format
<u>06/08/2006 – ANNUAL REPORT</u>	View image in PDF format
<u>05/01/2006 – ANNUAL REPORT</u>	View image in PDF format
<u>04/29/2005 – ANNUAL REPORT</u>	View image in PDF format
<u>03/11/2004 – ANNUAL REPORT</u>	View image in PDF format
<u>10/17/2003 – ANNUAL REPORT</u>	View image in PDF format
<u>05/12/2002 – ANNUAL REPORT</u>	View image in PDF format
<u>03/23/2001 – ANNUAL REPORT</u>	View image in PDF format
<u>03/23/2000 – ANNUAL REPORT</u>	View image in PDF format
<u>03/11/1999 – ANNUAL REPORT</u>	View image in PDF format
<u>11/09/1998 – Florida Limited Liabilities</u>	View image in PDF format



Florida Department of State, Division of Corporations



[Department of State](#) / [Division of Corporations](#) / [Search Records](#) / [Search by Entity Name](#) /

Detail by Entity Name

Florida Profit Corporation
PRITCHETT TRUCKING, INC.

Filing Information

Document Number	F47766
FEI/EIN Number	59-2129001
Date Filed	10/05/1981
State	FL
Status	ACTIVE
Last Event	AMENDMENT
Event Date Filed	09/24/1999
Event Effective Date	NONE

Principal Address

1050 SE 6TH STREET
LAKE BUTLER, FL 32054

Changed: 04/28/2009

Mailing Address

PO BOX 311
LAKE BUTLER, FL 32054

Changed: 06/30/2020

Registered Agent Name & Address

PRITCHETT, JON W
1050 SE 6TH STREET
LAKE BUTLER, FL 32054

Name Changed: 04/30/2014

Address Changed: 04/30/2014

Officer/Director Detail

Name & Address

Title President, Secretary, Treasurer

PRITCHETT, JON W
1050 SE 6TH STREET
LAKE BUTLER, FL 32054

Title VP

PRITCHETT, PHILLIP W
1050 SE 6TH ST
LAKE BUTLER, FL 32054

Annual Reports

Report Year	Filed Date
2021	04/29/2021
2022	04/29/2022
2023	04/28/2023

Document Images

04/28/2023 -- ANNUAL REPORT	View Image in PDF format
04/29/2022 -- ANNUAL REPORT	View image in PDF format
04/29/2021 -- ANNUAL REPORT	View Image in PDF format
06/30/2020 -- ANNUAL REPORT	View Image in PDF format
04/25/2019 -- ANNUAL REPORT	View Image in PDF format
04/27/2018 -- ANNUAL REPORT	View Image in PDF format
04/25/2017 -- ANNUAL REPORT	View Image in PDF format
04/29/2016 -- AMENDED ANNUAL REPORT	View Image in PDF format
04/27/2016 -- ANNUAL REPORT	View Image in PDF format
04/09/2015 -- ANNUAL REPORT	View Image in PDF format
04/30/2014 -- ANNUAL REPORT	View Image in PDF format
04/12/2013 -- ANNUAL REPORT	View Image in PDF format
04/18/2012 -- ANNUAL REPORT	View Image in PDF format
04/08/2011 -- ANNUAL REPORT	View Image in PDF format
03/29/2010 -- ANNUAL REPORT	View image in PDF format
04/28/2009 -- ANNUAL REPORT	View image in PDF format
05/01/2008 -- ANNUAL REPORT	View image in PDF format
06/19/2007 -- ANNUAL REPORT	View image in PDF format
04/24/2006 -- ANNUAL REPORT	View image in PDF format
04/29/2005 -- ANNUAL REPORT	View image in PDF format
04/29/2004 -- ANNUAL REPORT	View image in PDF format
04/23/2003 -- ANNUAL REPORT	View image in PDF format
05/02/2002 -- ANNUAL REPORT	View image in PDF format
05/01/2001 -- ANNUAL REPORT	View Image in PDF format
05/10/2000 -- ANNUAL REPORT	View image in PDF format
09/24/1999 -- Amendment	View image in PDF format
06/30/1999 -- Merger	View image in PDF format
04/29/1999 -- ANNUAL REPORT	View image in PDF format
04/30/1998 -- ANNUAL REPORT	View Image in PDF format

04/30/1997 -- ANNUAL REPORT

[View image in PDF format](#)

04/30/1996 -- ANNUAL REPORT

[View Image In PDF format](#)

05/01/1995 -- ANNUAL REPORT

[View Image In PDF format](#)



Department of State / Division of Corporations / Search Records / Search by Entity Name /

Detail by Entity Name

Florida Profit Corporation
COUNTY MATERIALS CORP.

Filing Information

Document Number P12000039931
FEI/EIN Number 45-5296142
Date Filed 04/27/2012
State FL
Status ACTIVE
Last Event CORPORATE MERGER
Event Date Filed 05/22/2012
Event Effective Date 07/01/2012

Principal Address

25726 C.R. 561
ASTATULA, FL 34705

Mailing Address

POST OFFICE BOX 100
Marathon, WI 54448

Changed: 03/20/2013

Registered Agent Name & Address

SONNENTAG, TIM
25726 C.R. 561
ASTATULA, FL 34705

Name Changed: 04/27/2023

Officer/Director Detail

Name & Address

Title President

SONNENTAG, TIM
PO BOX 100
MARATHON, WI 54448

Title ST

STOEHR, ROBERT
P.O. BOX 173
MARATHON, WI 54448

Title VP

SONNENTAG, WILLIAM
PO BOX 100
MARATHON, WI 54448

Annual Reports

Report Year	Filed Date
2021	04/29/2021
2022	04/29/2022
2023	04/27/2023

Document Images

<u>04/27/2023 -- ANNUAL REPORT</u>	View image in PDF format
<u>04/29/2022 -- ANNUAL REPORT</u>	View image in PDF format
<u>11/05/2021 -- AMENDED ANNUAL REPORT</u>	View image in PDF format
<u>04/29/2021 -- ANNUAL REPORT</u>	View image in PDF format
<u>04/23/2020 -- ANNUAL REPORT</u>	View image in PDF format
<u>04/29/2019 -- ANNUAL REPORT</u>	View image in PDF format
<u>04/26/2018 -- ANNUAL REPORT</u>	View image in PDF format
<u>04/24/2017 -- ANNUAL REPORT</u>	View image in PDF format
<u>02/18/2016 -- ANNUAL REPORT</u>	View image in PDF format
<u>03/06/2015 -- ANNUAL REPORT</u>	View image in PDF format
<u>01/07/2014 -- ANNUAL REPORT</u>	View image in PDF format
<u>03/20/2013 -- ANNUAL REPORT</u>	View image in PDF format
<u>05/22/2012 -- Merger</u>	View image in PDF format
<u>05/21/2012 -- Amendment</u>	View image in PDF format
<u>04/27/2012 -- Domestic Profit</u>	View image in PDF format



Department of State / Division of Corporations / Search Records / Search by Entity Name /

Detail by Entity Name

Florida Profit Corporation
 MACK INDUSTRIES INC.

Filing Information

Document Number P20000067684
FEI/EIN Number 85-2822279
Date Filed 08/25/2020
State FL
Status ACTIVE
Last Event AMENDMENT AND NAME CHANGE
Event Date Filed 01/13/2023
Event Effective Date NONE

Principal Address

611 OLIVE TREE CT
 Clearwater, FL 33756

Changed: 01/13/2023

Mailing Address

611 OLIVE TREE CT
 Clearwater, FL 33756

Changed: 01/13/2023

Registered Agent Name & Address

DALLOUL RODRIGUEZ, KARIM
 611 OLIVE TREE CT
 Clearwater, FL 33756

Name Changed: 12/09/2021

Address Changed: 12/09/2021

Officer/Director Detail

Name & Address

Title P/D

DALLOUL RODRIGUEZ, KARIM
611 OLIVE TREE CT
Clearwater, FL 33756

Title S/T/D

PERRY, COLE ELAN
611 OLIVE TREE CT
Clearwater, FL 33756

Annual Reports

Report Year	Filed Date
2021	12/09/2021
2022	01/25/2022
2023	02/02/2023

Document Images

02/02/2023 — ANNUAL REPORT

[View image in PDF format](#)

01/13/2023 — Amendment and Name Change

[View image in PDF format](#)

01/25/2022 — ANNUAL REPORT

[View image in PDF format](#)

12/09/2021 — REINSTATEMENT

[View image in PDF format](#)

08/25/2020 — Domestic Profit

[View image in PDF format](#)



Department of State / Division of Corporations / Search Records / Search by Entity Name /

Detail by Entity Name

Florida Limited Liability Company
RADISE INTERNATIONAL, L.C.

Filing Information

Document Number L97000001085
FEI/EIN Number 65-0785837
Date Filed 09/30/1997
State FL
Status ACTIVE
Last Event LC STMNT OF AUTHORITY 21
Event Date Filed 01/23/2023
Event Effective Date NONE

Principal Address

4152 WEST BLUE HERON BOULEVARD
1114
RIVIERA BEACH, FL 33404

Changed: 01/08/2016

Mailing Address

4152 WEST BLUE HERON BOULEVARD
1114
RIVIERA BEACH, FL 33404

Changed: 06/12/2023

Registered Agent Name & Address

ALLADY, ACHYUT K
4152 WEST BLUE HERON BOULEVARD
1114
RIVIERA BEACH, FL 33404

Name Changed: 01/03/2012

Address Changed: 01/08/2016

Authorized Person(s) Detail

Name & Address

Title MGR

ALLADY, ACHYUT K
4152 WEST BLUE HERON BOULEVARD, # 1114
RIVIERA BEACH, FL 33404

Title MGR

ALLADY, VISHALAXMI
4152 WEST BLUE HERON BOULEVARD, # 1114
RIVIERA BEACH, FL 33404

Title MGR

Shanmugam, Panneer
4152 WEST BLUE HERON BOULEVARD
1114
RIVIERA BEACH, FL 33404

Title MGR

Masri, Fouad
4152 WEST BLUE HERON BOULEVARD
1114
RIVIERA BEACH, FL 33404

Annual Reports

Report Year	Filed Date
2022	02/17/2022
2023	01/19/2023
2023	06/12/2023

Document Images

<u>06/12/2023 -- AMENDED ANNUAL REPORT</u>	View Image in PDF format
<u>01/23/2023 -- CORLCAUTH</u>	View Image in PDF format
<u>01/19/2023 -- ANNUAL REPORT</u>	View Image in PDF format
<u>02/17/2022 -- ANNUAL REPORT</u>	View Image in PDF format
<u>01/18/2021 -- ANNUAL REPORT</u>	View Image in PDF format
<u>10/05/2020 -- CORLCAUTH</u>	View Image in PDF format
<u>01/15/2020 -- ANNUAL REPORT</u>	View Image in PDF format
<u>01/08/2019 -- ANNUAL REPORT</u>	View image in PDF format
<u>01/02/2018 -- ANNUAL REPORT</u>	View Image in PDF format
<u>01/04/2017 -- ANNUAL REPORT</u>	View Image in PDF format
<u>01/08/2016 -- ANNUAL REPORT</u>	View Image in PDF format
<u>01/07/2015 -- ANNUAL REPORT</u>	View image in PDF format
<u>01/13/2014 -- ANNUAL REPORT</u>	View image in PDF format
<u>01/04/2013 -- ANNUAL REPORT</u>	View Image in PDF format
<u>01/03/2012 -- ANNUAL REPORT</u>	View Image in PDF format
<u>01/06/2011 -- ANNUAL REPORT</u>	View Image in PDF format

<u>01/06/2010 -- ANNUAL REPORT</u>	View Image in PDF format
<u>01/13/2009 -- ANNUAL REPORT</u>	View Image in PDF format
<u>01/04/2008 -- ANNUAL REPORT</u>	View Image in PDF format
<u>01/17/2007 -- ANNUAL REPORT</u>	View Image in PDF format
<u>01/23/2006 -- ANNUAL REPORT</u>	View Image in PDF format
<u>01/10/2005 -- ANNUAL REPORT</u>	View Image in PDF format
<u>02/03/2004 -- ANNUAL REPORT</u>	View Image in PDF format
<u>01/09/2003 -- LIMITED LIABILITY CORPORATION</u>	View Image in PDF format
<u>02/18/2002 -- ANNUAL REPORT</u>	View Image in PDF format
<u>04/23/2001 -- ANNUAL REPORT</u>	View Image in PDF format
<u>04/18/2000 -- ANNUAL REPORT</u>	View Image in PDF format
<u>03/29/1999 -- ANNUAL REPORT</u>	View Image in PDF format
<u>08/13/1998 -- ANNUAL REPORT</u>	View image in PDF format
<u>09/30/1997 -- FL LIMITED LIABILITY ARTICLES</u>	View image in PDF format



ADDENDUM #4

October 20, 2023

To: Prospective Bidders
From: St. Johns County Purchasing Division
Subject: Bid No: 23-94 CR 210 Widening from Trinity Way to Beachwalk Boulevard

This Addendum #4 is issued for further Bidders' information, and is hereby incorporated into the BID Documents. Each Bidder must incorporate any and all revisions, clarifications, and/or supplemental information provided in all issued addenda with the submitted Bid. Bidders must submit a copy of each signed addendum with their Bid as provided in the Bid Documents.

Revisions/Clarifications:

The County provides the following revisions and/or clarifications to be incorporated into the Bid Documents:

1. Replace Table of Contents page 2 of the Bid Document and replace with same page contained in this Addendum.
2. Remove Attachment "P" – Addendum #3 Revised Schedule of Values – Eighteen (18) Months Completion Time and replace with Revised Attachment "P" – Addendum #4 Revised Schedule of Values – Eighteen (18) Months Completion Time contained in this Addendum.

SUBMITTAL DEADLINE FOR BIDS REMAINS WEDNESDAY, OCTOBER 25, 2023 AT 2:00 PM (EDST)

Bidder Acknowledgment:

Signature

Printed Name/Title

Respondent Company Name

END OF ADDENDUM NO. #4

BID NO: 23-94; CR 210 Widening from Trinity Way to Beachwalk Boulevard – Revised Per Addendum #3

TABLE OF CONTENTS

- I. General Terms and Conditions
- II. Revised Official County Bid Form
- III. Attachments:
 - Attachment "A" – St Johns County Board of County Commissioners Affidavit
 - Attachment "B" – Certificate as to Corporate Principal
 - Attachment "C" – Contractor's Qualification Statement
 - Attachment "D" – License/Certification/FDOT Work Class Pre-Qualification List
 - Attachment "E" – List of Proposed Sub-Contractors/Suppliers
 - Attachment "F" – Conflict of Interest Disclosure Form
 - Attachment "G" – Drug Free Work Place Form
 - Attachment "H" – Proof of Insurance
 - Attachment "I" – Relevant Experience of Bidder
 - Attachment "J" – Claims, Liens, Litigation History
 - Attachment "K" – Public Entity Crimes Statement
 - Attachment "L" – Non-collusion Certification
 - Attachment "M" – E-Verify Affidavit
 - Attachment "N" – Certificate of Compliance with Florida Trench Safety Act
 - Attachment "O" – Local Preference
 - Attachment "P" – Addendum #4 Revised Schedule of Values – Eighteen (18) Months Completion Time
 - Bid Bond
 - Sealed Bid Mailing Label

SEPARATE DOCUMENTS:

- EXHIBIT "A" – CR 210 WIDENING CONSTRUCTION PLANS – Dated September 2023**
- EXHIBIT "B" – ECS FLORIDA LLC. GEOTECHNICAL REPORT - Dated December 27, 2019**
- EXHIBIT "C" – ST. JOHNS RIVER WATER MANAGEMENT PERMIT 99121-21 – Dated September 16, 2016**
- EXHIBIT "D" – TEMPORARY TRAFFIC CONTROL PLAN**
- EXHIBIT "E" – CR 210 SIGNAL PLANS FOR COORDINATION AND INFORMATION**

END OF TABLE OF CONTENTS

BID NO: 23-94; CR 210 Widening from Trinity Way to Beachwalk Boulevard

**ATTACHMENT – “P” ADDENDUM #4
REVISED SCHEDULE OF VALUES - EIGHTEEN (18) MONTHS COMPLETION TIME**

Bidders shall complete and submit with their Bid Proposal this Schedule of Values to demonstrate the breakdown of costs included in the submitted Lump Sum Bid Price. Quantities provided herein are estimates only and Bidders are responsible for appropriately estimating quantities for inclusion in the

Bid Item	Pay Item	Description	Unit	Quantity	Cost Per Unit	Total Cost
General						
1	101 1	MOBILIZATION	LS	1	\$	\$
2	101 2	MAINTENANCE OF TRAFFIC	LS	1	\$	\$
3	104 10 3	SEDIMENT BARRIER	LF	6,655	\$	\$
4	104 12	STAKED TURBIDITY BARRIER	LF	690	\$	\$
5	104 18	INLET PROTECTION SYSTEM	EA	47	\$	\$
6	110 1 1	CLEARING AND GRUBBING	AC	10	\$	\$
7	110 4 10	REMOVAL OF EXISTING CONCRETE	SY	1,985	\$	\$
8	0107 2	MOWING (18 MONTH DURATION)	AC	230	\$	\$
9	0107 1	LITTER REMOVAL	AC	312	\$	\$
General Sub-Total						\$
Roadway						
10	120 1	REGULAR EXCAVATION	CY	3,685	\$	\$
11	120 6	EMBANKMENT	CY	21,194	\$	\$
12	160 4	TYPE B STABILIZATION	SY	40,679	\$	\$
13	285 711	OPTIONAL BASE GROUP 11, 12" LIMEROCK	SY	39,472	\$	\$
14	327 70 6	MILLING EXISTING ASPHALT PAVEMENT, 1 1/2" AVG DEPTH	SY	5,217	\$	\$
15	334 1 12	SUPERPAVE ASPHALT PAVEMENT, TRAFFIC B (3")	TN	5,960	\$	\$
16	334 1 12	SUPERPAVE ASPHALT PAVEMENT, TRAFFIC B (1.5")	TN	3,410	\$	\$
17	520 1 10	CONCRETE CURB & GUTTER, TYPE F	LF	9,278	\$	\$
18	520 5 41	TRAFFIC SEPARATOR CONCRETE - TYPE IV, 4' WIDE	LF	1,380	\$	\$
19	522 1	CONCRETE SIDEWALK AND DRIVEWAYS, 4" THICK	SY	3,316	\$	\$
20	522 2	CONCRETE SIDEWALK AND DRIVEWAYS, 6" THICK	SY	490	\$	\$
21	522	CONCRETE SIDEWALK WITH THICKENED EDGE, 4" THICK	SY	156	\$	\$
22	527 2	DETECTABLE WARNINGS	SF	251	\$	\$

23	570 1 1	PERFORMANCE TURF	SY	13,990	\$	\$
24	570 1 2	PERFORMANCE TURF, SOD	SY	6,012	\$	\$
25	0515 2311	PEDESTRIAN RAILING (ALUMINUM)	LF	260	\$	\$
Roadway Sub-Total						\$
Drainage						
26	425 1 311	INLETS, CURB, TYPE P-1, <10'	EA	9	\$	\$
27	425 1 315	INLETS, CURB TYPE P-1, >10'	EA	1	\$	\$
28	425 1 321	INLETS, CURB, TYPE P-2, <10'	EA	7	\$	\$
29	425 1 411	INLETS, CURB, TYPE J-1, <10'	EA	2	\$	\$
30	425 1 412	INLETS, CURB, TYPE J-1, >10'	EA	4	\$	\$
31	0425 1315	INLETS, CURB, TYPE 1 TOP ONLY	EA	2	\$	\$
32	425 1 421	INLETS, CURB, TYPE J-2, <10'	EA	7	\$	\$
33	425 1 471	INLETS, CURB, TYPE P- 7, <10'	EA	5	\$	\$
34	425 1 521	INLETS, DT BOT, TYPE C, <10'	EA	3	\$	\$
35	0425 1524	INLETS, DT BOT, TYPE C, >10'	EA	1	\$	\$
36	425 1 541	INLETS, DT BOT, TYPE D, <10'	EA	5	\$	\$
37	425 2 61	MANHOLES, P-8, <10'	EA	1	\$	\$
38	425 2 92	MANHOLES, J-8, >10'	EA	4	\$	\$
39	0425 2 91	MANHOLES, J-8, <10'	EA	1	\$	\$
40	430 175 118	PIPE CULVERT, OPTIONAL MATERIAL, ROUND 18"	LF	1,320	\$	\$
41	430 175 124	PIPE CULVERT, OPTIONAL MATERIAL, ROUND 24"	LF	274	\$	\$
42	430 175 130	PIPE CULVERT, OPTIONAL MATERIAL, ROUND 30"	LF	468	\$	\$
43	430 175 136	PIPE CULVERT, OPTIONAL MATERIAL, ROUND 36"	LF	748	\$	\$
44	430 175 142	PIPE CULVERT, OPTIONAL MATERIAL, ROUND 42"	LF	843	\$	\$
45	430 175 148	PIPE CULVERT, OPTIONAL MATERIAL, ROUND 48"	LF	855	\$	\$
46	430 174 218	PIPE CULVERT, OPTIONAL MATERIAL, OTHER SHAPE, ELLIP/ARCH, 14" x 23"	LF	442	\$	\$
47	430 174 224	PIPE CULVERT, OPTIONAL MATERIAL, OTHER SHAPE, ELLIP/ARCH, 19"x 30"	LF	325	\$	\$
48	430 530 100	STRAIGHT CONCRETE ENDWALL, 30", QUAD	EA	2	\$	\$
49	430 984 625	MITERED END SECTION, OPTIONAL - ELLIP/ARCH, 14" x 23"	EA	6	\$	\$
50	430 984 629	MITERED END SECTION, OPTIONAL - ELLIP/ARCH, 19"x 30"	EA	2	\$	\$

51	425	CONCRETE FLUME	EA	2	\$	\$
52	0425 11	MODIFY EXISITNG DRAINAGE STRUCTURE (POND CONTROL)	EA	1	\$	\$
53	425	P-BOTTOM W/ 8" TOP SLAB	EA	1	\$	\$
Drainage Sub-total						\$
Signing and Pavement Marking						
54	700 1 11	SINGLE POST SIGN, F&I GROUND MOUNT, UP TO 12 SF	EA	39	\$	\$
55	700 1 12	SINGLE POST SIGN, F&I GROUND MOUNT, 12-20 SF	EA	2	\$	\$
56	700 1 50	SINGLE POST SIGN, RELOCATE	EA	1	\$	\$
57	700 1 60	SINGLE POST SIGN, REMOVE	EA	17	\$	\$
58	706 1 3	RAISED PAVEMENT MARKER, TYPE B	EA	917	\$	\$
59	711 11 102	THERMOPLASTIC, STANDARD, WHITE, SOLID 8"	LF	437	\$	\$
60	711 11 123	THERMOPLASTIC, STANDARD, WHITE, SOLID 12"	LF	1,697	\$	\$
61	711 11 124	THERMOPLASTIC, STANDARD, WHITE, SOLID 18"	LF	513	\$	\$
62	711 11 125	THERMOPLASTIC, STANDARD, WHITE, SOLID 24"	LF	450	\$	\$
63	711 11 141	THERMOPLASTIC, STANDARD, WHITE, 2-4 DOTTED GUIDELINE, 6"	GM	0.51	\$	\$
64	711 11 160	THERMOPLASTIC, PREFORMED, WHITE, MESSAGE	EA	33	\$	\$
65	711 11 170	THERMOPLASTIC, PREFORMED, WHITE, ARROW	EA	101	\$	\$
66	711 11 224	THERMOPLASTIC, STANDARD, YELLOW, SOLID 18"	LF	170	\$	\$
67	711 15 101	THERMOPLASTIC, STANDARD OG ASPHALT, WHITE, SOLID, 6"	GM	3.77	\$	\$
68	711 15 131	THERMOPLASTIC, STANDARD OG ASPHALT, WHITE, SKIP, 6" 10-30 SKIP	GM	2.87	\$	\$
69	711 15 201	THERMOPLASTIC, STANDARD OG ASPHALT, YELLOW, SOLID, 6"	GM	2.05	\$	\$
Signing and Marking Sub-Total						\$
Total Lump Sum Bid Price						
Total Lump Sum Bid Price						\$



ADDENDUM #3

October 19, 2023

To: Prospective Bidders
From: St. Johns County Purchasing Division
Subject: Bid No: 23-94 CR 210 Widening from Trinity Way to Beachwalk Boulevard

This Addendum #3 is issued for further Bidders' information, and is hereby incorporated into the BID Documents. Each Bidder must incorporate any and all revisions, clarifications, and/or supplemental information provided in all issued addenda with the submitted Bid. Bidders must submit a copy of each signed addendum with their Bid as provided in the Bid Documents.

Revisions/Clarifications:

The County provides the following revisions and/or clarifications to be incorporated into the Bid Documents:

1. Replace Table of Contents page 2 of the Bid Document and replace with same page contained in this Addendum.
2. Remove Attachment "P" – Addendum #2 Revised Schedule of Values – Eighteen (18) Months Completion Time and replace with Revised Attachment "P" – Addendum #3 Revised Schedule of Values – Eighteen (18) Months Completion Time contained in this Addendum.

SUBMITTAL DEADLINE FOR BIDS REMAINS WEDNESDAY, OCTOBER 25, 2023 AT 2:00 PM (EDST)

Bidder Acknowledgment:

Signature

Printed Name/Title

Respondent Company Name

END OF ADDENDUM NO. #3

BID NO: 23-94; CR 210 Widening from Trinity Way to Beachwalk Boulevard – Revised Per Addendum #3

TABLE OF CONTENTS

- I. General Terms and Conditions
- II. Revised Official County Bid Form
- III. Attachments:
 - Attachment “A” – St Johns County Board of County Commissioners Affidavit
 - Attachment “B” – Certificate as to Corporate Principal
 - Attachment “C” – Contractor’s Qualification Statement
 - Attachment “D” – License/Certification/FDOT Work Class Pre-Qualification List
 - Attachment “E” – List of Proposed Sub-Contractors/Suppliers
 - Attachment “F” – Conflict of Interest Disclosure Form
 - Attachment “G” – Drug Free Work Place Form
 - Attachment “H” – Proof of Insurance
 - Attachment “I” – Relevant Experience of Bidder
 - Attachment “J” – Claims, Liens, Litigation History
 - Attachment “K” – Public Entity Crimes Statement
 - Attachment “L” – Non-collusion Certification
 - Attachment “M” – E-Verify Affidavit
 - Attachment “N” – Certificate of Compliance with Florida Trench Safety Act
 - Attachment “O” – Local Preference
 - Attachment “P” – Addendum #3 Revised Schedule of Values – Eighteen (18) Months Completion Time
 - Bid Bond
 - Sealed Bid Mailing Label

SEPARATE DOCUMENTS:

- EXHIBIT “A” – CR 210 WIDENING CONSTRUCTION PLANS – Dated September 2023**
- EXHIBIT “B” – ECS FLORIDA LLC. GEOTECHNICAL REPORT - Dated December 27, 2019**
- EXHIBIT “C” – ST. JOHNS RIVER WATER MANAGEMENT PERMIT 99121-21 – Dated September 16, 2016**
- EXHIBIT “D” – TEMPORARY TRAFFIC CONTROL PLAN**
- EXHIBIT “E” – CR 210 SIGNAL PLANS FOR COORDINATION AND INFORMATION**

END OF TABLE OF CONTENTS

BID NO: 23-94; CR 210 Widening from Trinity Way to Beachwalk Boulevard

**ATTACHMENT – “P” ADDENDUM #3
REVISED SCHEDULE OF VALUES - EIGHTEEN (18) MONTHS COMPLETION TIME**

Bidders shall complete and submit with their Bid Proposal this Schedule of Values to demonstrate the breakdown of costs included in the submitted Lump Sum Bid Price. Quantities provided herein are estimates only and Bidders are responsible for appropriately estimating quantities for inclusion in the submitted Lump Sum Bid Price.

Bid Item	Pay Item	Description	Unit	Quantity	Cost Per Unit	Total Cost
General						
1	101 1	MOBILIZATION	LS	1	\$	\$
2	101 2	MAINTENANCE OF TRAFFICE	LS	1	\$	\$
3	104 10 3	SEDIMENT BARRIER	LF	6,655	\$	\$
4	104 12	STAKED TURBIDITY BARRIER	LF	690	\$	\$
5	104 18	INLET PROTECTION SYSTEM	EA	47	\$	\$
6	110 1 1	CLEARING AND GRUBBING	AC	10	\$	\$
7	110 4 10	REMOVAL OF EXISTING CONCRETE	SY	1,985	\$	\$
8	0107 2	MOWING (18 MONTH DURATION)	AC	230	\$	\$
9	0107 1	LITTER REMOVAL	AC	312	\$	\$
General Sub-Total						
Roadway						
10	120 1	REGULAR EXCAVATION	CY	3,685	\$	\$
11	120 6	EMBANKMENT	CY	21,194	\$	\$
12	160 4	TYPE B STABILIZATION	SY	40,679	\$	\$
13	285 711	OPTIONAL BASE GROUP 11, 12" LIMEROCK	SY	39,472	\$	\$
14	327 70 6	MILLING EXISTING ASPHALT PAVEMENT, 1 1/2" AVG DEPTH	SY	5,217	\$	\$
15	334 1 12	SUPERPAVE ASPHALT PAVEMENT, TRAFFIC B (3")	TN	5,950	\$	\$
16	337 7 80	ASPHALT CONCRETE FRICTION COURSE, TRAFFIC B, FC-9.5, PG 76-22 (1.5")	TN	3,410	\$	\$
17	520 1 10	CONCRETE CURB & GUTTER, TYPE F	LF	9,278	\$	\$
18	520 5 41	TRAFFIC SEPARATOR CONCRETE - TYPE IV, 4' WIDE	LF	1,380	\$	\$
19	522 1	CONCRETE SIDEWALK AND DRIVEWAYS, 4" THICK	SY	3,316	\$	\$
20	522 2	CONCRETE SIDEWALK AND DRIVEWAYS, 6" THICK	SY	490	\$	\$
21	522	CONCRETE SIDEWALK WITH THICKENED EDGE, 4" THICK	SY	156	\$	\$
22	527 2	DETECTABLE WARNINGS	SF	251	\$	\$
23	570 1 1	PERFORMANCE TURF	SY	13,990	\$	\$
24	570 1 2	PERFORMANCE TURF, SOD	SY	6,012	\$	\$
25	0515 2311	PEDESTRIAN RAILING (ALUMINUM)	LF	260	\$	\$
Roadway Sub-Total						

Drainage						
26	425 1 311	INLETS, CURB, TYPE P-1, <10'	EA	9	\$	\$
27	425 1 315	INLETS, CURB TYPE P-1, >10'	EA	1	\$	\$
28	425 1 321	INLETS, CURB, TYPE P-2, <10'	EA	7	\$	\$
29	425 1 411	INLETS, CURB, TYPE J-1, <10'	EA	2	\$	\$
30	425 1 412	INLETS, CURB, TYPE J-1, >10'	EA	4	\$	\$
31	0425 1315	INLETS, CURB, TYPE 1 TOP ONLY	EA	2	\$	\$
32	425 1 421	INLETS, CURB, TYPE J-2, <10'	EA	7	\$	\$
33	425 1 471	INLETS, CURB, TYPE P- 7, <10'	EA	5	\$	\$
34	425 1 521	INLETS, DT BOT, TYPE C, <10'	EA	3	\$	\$
35	0425 1524	INLETS, DT BOT, TYPE C, >10'	EA	1	\$	\$
36	425 1 541	INLETS, DT BOT, TYPE D, <10'	EA	5	\$	\$
37	425 2 61	MANHOLES, P-8, <10'	EA	1	\$	\$
38	425 2 92	MANHOLES, J-8, >10'	EA	4	\$	\$
39	0425 2 91	MANHOLES, J-8, <10'	EA	1	\$	\$
40	430 175 118	PIPE CULVERT, OPTIONAL MATERIAL, ROUND 18"	LF	1,320	\$	\$
41	430 175 124	PIPE CULVERT, OPTIONAL MATERIAL, ROUND 24"	LF	274	\$	\$
42	430 175 130	PIPE CULVERT, OPTIONAL MATERIAL, ROUND 30"	LF	468	\$	\$
43	430 175 136	PIPE CULVERT, OPTIONAL MATERIAL, ROUND 36"	LF	748	\$	\$
44	430 175 142	PIPE CULVERT, OPTIONAL MATERIAL, ROUND 42"	LF	843	\$	\$
45	430 175 148	PIPE CULVERT, OPTIONAL MATERIAL, ROUND 48"	LF	855	\$	\$
46	430 174 218	PIPE CULVERT, OPTIONAL MATERIAL, OTHER SHAPE, ELLIP/ARCH, 14" x 23"	LF	442	\$	\$
47	430 174 224	PIPE CULVERT, OPTIONAL MATERIAL, OTHER SHAPE, ELLIP/ARCH, 19"x 30"	LF	325	\$	\$
48	430 530 100*	STRAIGHT CONCRETE ENDWALL, 30", QUAD	EA	2	\$	\$
49	430 984 625	MITERED END SECTION, OPTIONAL - ELLIP/ARCH, 14" x 23"	EA	6	\$	\$
50	430 984 629	MITERED END SECTION, OPTIONAL - ELLIP/ARCH, 19"x 30"	EA	2	\$	\$
51	425	CONCRETE FLUME	EA	2	\$	\$
52	0425 11	MODIFY EXISITNG DRAINAGE STRUCTURE (POND CONTROL)	EA	1	\$	\$
53	425	P-BOTTOM W/ 8" TOP SLAB	EA	1	\$	\$
					Drainage Sub-total	\$
Signing and Pavement Marking						
54	700 1 11	SINGLE POST SIGN, F&I GROUND MOUNT, UP TO 12 SF	EA	39	\$	\$
55	700 1 12	SINGLE POST SIGN, F&I GROUND MOUNT, 12-20 SF	EA	2	\$	\$
56	700 1 50	SINGLE POST SIGN, RELOCATE	EA	1	\$	\$

57	700 1 60	SINGLE POST SIGN, REMOVE	EA	17	\$	\$
58	706 1 3	RAISED PAVEMENT MARKER, TYPE B	EA	917	\$	\$
59	711 11 102	THERMOPLASTIC, STANDARD, WHITE, SOLID 8"	LF	437	\$	\$
60	711 11 123	THERMOPLASTIC, STANDARD, WHITE, SOLID 12"	LF	1,697	\$	\$
61	711 11 124	THERMOPLASTIC, STANDARD, WHITE, SOLID 18"	LF	513	\$	\$
62	711 11 125	THERMOPLASTIC, STANDARD, WHITE, SOLID 24"	LF	450	\$	\$
63	711 11 141	THERMOPLASTIC, STANDARD, WHITE, 2-4 DOTTED GUIDELINE, 6"	GM	0.51	\$	\$
64	711 11 160	THERMOPLASTIC, PREFORMED, WHITE, MESSAGE	EA	33	\$	\$
65	711 11 170	THERMOPLASTIC, PREFORMED, WHITE, ARROW	EA	101	\$	\$
66	711 11 224	THERMOPLASTIC, STANDARD, YELLOW, SOLID 18"	LF	170	\$	\$
67	711 15 101	THERMOPLASTIC, STANDARD OG ASPHALT, WHITE, SOLID, 6"	GM	3.77	\$	\$
68	711 15 131	THERMOPLASTIC, STANDARD OG ASPHALT, WHITE, SKIP, 6" 10-30 SKIP	GM	2.87	\$	\$
69	711 15 201	THERMOPLASTIC, STANDARD OG ASPHALT, YELLOW, SOLID, 6"	GM	2.05	\$	\$
			Signing and Marking Sub-Total			\$
		Total Lump Sum Bid Price	\$			



ADDENDUM #2

October 12, 2023

To: Prospective Bidders
From: St. Johns County Purchasing Division
Subject: Bid No: 23-94 CR 210 Widening from Trinity Way to Beachwalk Boulevard

This Addendum #2 is issued for further Bidders' information, and is hereby incorporated into the BID Documents. Each Bidder must incorporate any and all revisions, clarifications, and/or supplemental information provided in all issued addenda with the submitted Bid. Bidders must submit a copy of each signed addendum with their Bid as provided in the Bid Documents.

Revisions/Clarifications:

The County provides the following revisions and/or clarifications to be incorporated into the Bid Documents:

1. Replace Table of Contents page 2 of the Bid Document and replace with same page contained in this Addendum.
2. Remove the Official County Bid Form pages 18 and 19 and replace with the same pages contained in this Addendum.
3. Remove Attachment "P" – Schedule of Values – Eighteen (18) Months Completion Time and replace with Revised Attachment "P" – Addendum #2 Revised Schedule of Values – Eighteen (18) Months Completion Time contained in this Addendum.
4. Add Exhibit "D" – Temporary Traffic Control Plan contained in this Addendum.
5. Add Exhibit "E" – CR 210 Signal Plans for Coordination and Information contained in this Addendum.
6. Due to the release of Addendum #2, the Bid Opening initially scheduled for Wednesday, 2:00 PM on October 18, 2023 (EDST) is hereby changed to Wednesday, 2:00 PM on October 25, 2023 (EDST).

SUBMITTAL DEADLINE FOR BIDS IS HEREBY CHANGED TO, WEDNESDAY, OCTOBER 25, 2023 AT 2:00 PM (EDST)

Bidder Acknowledgment:

Signature

Printed Name/Title

Respondent Company Name

END OF ADDENDUM NO. #2

BID NO: 23-94; CR 210 Widening from Trinity Way to Beachwalk Boulevard – Revised Per Addendum #2

TABLE OF CONTENTS

- I. General Terms and Conditions
- II. Revised Official County Bid Form
- III. Attachments:
 - Attachment “A” – St Johns County Board of County Commissioners Affidavit
 - Attachment “B” – Certificate as to Corporate Principal
 - Attachment “C” – Contractor’s Qualification Statement
 - Attachment “D” – License/Certification/FDOT Work Class Pre-Qualification List
 - Attachment “E” – List of Proposed Sub-Contractors/Suppliers
 - Attachment “F” – Conflict of Interest Disclosure Form
 - Attachment “G” – Drug Free Work Place Form
 - Attachment “H” – Proof of Insurance
 - Attachment “I” – Relevant Experience of Bidder
 - Attachment “J” – Claims, Liens, Litigation History
 - Attachment “K” – Public Entity Crimes Statement
 - Attachment “L” – Non-collusion Certification
 - Attachment “M” – E-Verify Affidavit
 - Attachment “N” – Certificate of Compliance with Florida Trench Safety Act
 - Attachment “O” – Local Preference
 - Attachment “P” – Addendum #2 Revised Schedule of Values – Eighteen (18) Months Completion Time
 - Bid Bond
 - Sealed Bid Mailing Label

SEPARATE DOCUMENTS:

- EXHIBIT “A” – CR 210 WIDENING CONSTRUCTION PLANS – Dated September 2023**
- EXHIBIT “B” – ECS FLORIDA LLC. GEOTECHNICAL REPORT - Dated December 27, 2019**
- EXHIBIT “C” – ST. JOHNS RIVER WATER MANAGEMENT PERMIT 99121-21 – Dated September 16, 2016**
- EXHIBIT “D” – TEMPORARY TRAFFIC CONTROL PLAN**
- EXHIBIT “E” – CR 210 SIGNAL PLANS FOR COORDINATION AND INFORMATION**

END OF TABLE OF CONTENTS

OFFICIAL COUNTY BID FORM
ST. JOHNS COUNTY, FLORIDA

TO: THE BOARD OF COUNTY COMMISSIONERS OF ST. JOHNS COUNTY, FLORIDA

DATE SUBMITTED: _____

BID PROPOSAL OF

Full Legal Company Name

Mailing Address

Telephone Number

Fax Number

Bidders: Having become familiar with requirements of the project, and having carefully examined the Bidding Documents and Specifications entitled for Bid No: 23-94; CR 210 Widening from Trinity Way to Beachwalk Boulevard in St. Johns County, Florida, the undersigned proposes to furnish all materials, labor and equipment, supervision and all other requirements necessary to comply with the Contract Documents to submit the following Bid Proposal summarized as follows:

Total Lump Sum Bid: 18 Months Completion Time: (As per Exhibit A – CR 210 Widening from Trinity Way to Beachwalk Boulevard Construction Plans – Dated September 2023). The Base Bid includes all work to construct the project from Trinity Way to Beachwalk Boulevard, as shown on the base bid plan sheets.

\$ _____

Lump Sum Bid Price (Numerical)

_____/100 Dollars

Lump Sum Bid Price (Amount written or typed in words)

Bidder shall insert the Lump Sum Bid Price above, in numerals and in words. In the event of a discrepancy between the two, the amount shall be determined by the amount written in words.

Bid Alternate – (Add Cost) Temporary Traffic Control Plan: (As per Exhibit D)

\$ _____

Lump Sum Bid Price (Written in Numerical)

_____/100 Dollars

Lump Sum Bid Price (Amount written or typed in words)

BID NO: 23-94; CR 210 Widening from Trinity Way to Beachwalk Boulevard – Revised Per Addendum #2

During the preparation of the Bid, the following addenda, if any, were received:

No.: _____ Date Received:

No.: _____ Date Received:

No.: _____ Date Received:

We, the undersigned, hereby declare that no person or persons, firm or corporation, other than the undersigned are interested, in this proposal, as principals, and that this proposal is made without collusion with any person, firm or corporation, and we have carefully and to our satisfaction examined the Bid Documents and Project Specifications.

We have made a full examination of the location of the proposed work and the sources of supply of materials, and we hereby agree to furnish all necessary labor, equipment and materials, fully understanding that any quantities shown therewith are approximate only, and that we will fully complete all requirements therein as prepared by the County, within the same time limit specified in the Bid Documents as indicated above.

If the Undersigned is notified of the acceptance of this Bid Proposal by the Board within ninety (90) calendar days for the time set for the opening of Bids, the Undersigned further agrees, to execute a contract for the above work within ten (10) days after notice that his Bid has been accepted for the above stated compensation in the form of a Contract presented by the County.

The Undersigned further agrees that security in the form of a Bid Bond, certified or cashier's check in the amount of not less than **five percent (5%) of Total Lump Sum Bid Price**, payable to the County, accompanies this Bid; that the amount is not to be construed as a penalty, but as liquidated damages which said County will sustain by failure of the Undersigned to execute and deliver the Contract and Bond within ten (10) days of the written notification of the Award of the Contract to him; thereupon, the security shall become the property of the County, but if this Bid is not accepted within ninety (90) days of the time set for the submission of Bids, or if the Undersigned delivers the executed Contract upon receipt, the Security shall be returned to the Bidder within seven (7) working days.

BID NO: 23-94; CR 210 Widening from Trinity Way to Beachwalk Boulevard

**ATTACHMENT – “P” ADDENDUM #2
REVISED SCHEDULE OF VALUES - EIGHTEEN (18) MONTHS COMPLETION TIME**

Bidders shall complete and submit with their Bid Proposal this Schedule of Values to demonstrate the breakdown of costs included in the submitted Lump Sum Bid Price. Quantities provided herein are estimates only and Bidders are responsible for appropriately estimating quantities for inclusion in the submitted Lump Sum Bid Price.

Bid Item	Pay Item	Description	Unit	Quantity	Cost Per Unit	Total Cost
General						
1	101 1	MOBILIZATION	LS	1	\$	\$
2	104 10 3	SEDIMENT BARRIER	LF	6,655	\$	\$
3	104 12	STAKED TURBIDITY BARRIER	LF	690	\$	\$
4	104 18	INLET PROTECTION SYSTEM	EA	47	\$	\$
5	110 1 1	CLEARING AND GRUBBING	AC	10	\$	\$
6	110 4 10	REMOVAL OF EXISTING CONCRETE	SY	1,985	\$	\$
7	0107 2	MOWING (18 MONTH DURATION)	AC	230	\$	\$
8	0107 1	LITTER REMOVAL	AC	312	\$	\$
General Sub-Total						
Roadway						
9	120 1	REGULAR EXCAVATION	CY	3,685	\$	\$
10	120 6	EMBANKMENT	CY	21,194	\$	\$
11	0120 2 2	BORROW EXCAVATION	CY	21,214	\$	\$
12	160 4	TYPE B STABILIZATION	SY	40,679	\$	\$
13	285 711	OPTIONAL BASE GROUP 11, 12" LIMEROCK	SY	39,472	\$	\$
14	327 70 6	MILLING EXISTING ASPHALT PAVEMENT, 1 1/2" AVG DEPTH	SY	24,877	\$	\$
15	334 1 12	SUPERPAVE ASPHALT PAVEMENT, TRAFFIC B (3")	TN	5,032	\$	\$
16	337 7 80	ASPHALT CONCRETE FRICTION COURSE, TRAFFIC B, FC-9.5, PG 76-22 (1.5")	TN	5,959	\$	\$
17	520 1 10	CONCRETE CURB & GUTTER, TYPE F	LF	9,278	\$	\$
18	520 5 41	TRAFFIC SEPARATOR CONCRETE - TYPE IV, 4' WIDE	LF	1,380	\$	\$
19	522 1	CONCRETE SIDEWALK AND DRIVEWAYS, 4" THICK	SY	3,316	\$	\$
20	522 2	CONCRETE SIDEWALK AND DRIVEWAYS, 6" THICK	SY	490	\$	\$
21	522	CONCRETE SIDEWALK WITH THICKENED EDGE, 4" THICK	SY	156	\$	\$
22	527 2	DETECTABLE WARNINGS	SF	251	\$	\$
23	570 1 1	PERFORMANCE TURF	SY	13,990	\$	\$
24	570 1 2	PERFORMANCE TURF, SOD	SY	20,721	\$	\$
25	0515 2311	PEDESTRIAN RAILING (ALUMINUM)	LF	260	\$	\$
Roadway Sub-Total						

Drainage						
26	425 1 311	INLETS, CURB, TYPE P-1, <10'	EA	9	\$	\$
27	425 1 315	INLETS, CURB TYPE P-1, >10'	EA	1	\$	\$
28	425 1 321	INLETS, CURB, TYPE P-2, <10'	EA	7	\$	\$
29	425 1 411	INLETS, CURB, TYPE J-1, <10'	EA	2	\$	\$
30	425 1 412	INLETS, CURB, TYPE J-1, >10'	EA	4	\$	\$
31	0425 1315	INLETS, CURB, TYPE 1 TOP ONLY	EA	2	\$	\$
32	425 1 421	INLETS, CURB, TYPE J-2, <10'	EA	7	\$	\$
33	425 1 471	INLETS, CURB, TYPE P- 7, <10'	EA	5	\$	\$
34	425 1 521	INLETS, DT BOT, TYPE C, <10'	EA	3	\$	\$
35	0425 1524	INLETS, DT BOT, TYPE C, >10'	EA	1	\$	\$
36	425 1 541	INLETS, DT BOT, TYPE D, <10'	EA	5	\$	\$
37	425 2 61	MANHOLES, P-8, <10'	EA	1	\$	\$
38	425 2 92	MANHOLES, J-8, >10'	EA	4	\$	\$
39	0425 2 91	MANHOLES, J-8, <10'	EA	1	\$	\$
40	430 175 118	PIPE CULVERT, OPTIONAL MATERIAL, ROUND 18"	LF	1,320	\$	\$
41	430 175 124	PIPE CULVERT, OPTIONAL MATERIAL, ROUND 24"	LF	274	\$	\$
42	430 175 130	PIPE CULVERT, OPTIONAL MATERIAL, ROUND 30"	LF	468	\$	\$
43	430 175 136	PIPE CULVERT, OPTIONAL MATERIAL, ROUND 36"	LF	748	\$	\$
44	430 175 142	PIPE CULVERT, OPTIONAL MATERIAL, ROUND 42"	LF	843	\$	\$
45	430 175 148	PIPE CULVERT, OPTIONAL MATERIAL, ROUND 48"	LF	855	\$	\$
46	430 174 218	PIPE CULVERT, OPTIONAL MATERIAL, OTHER SHAPE, ELLIP/ARCH, 14" x 23"	LF	442	\$	\$
47	430 174 224	PIPE CULVERT, OPTIONAL MATERIAL, OTHER SHAPE, ELLIP/ARCH, 19"x 30"	LF	325	\$	\$
48	430 530 100*	STRAIGHT CONCRETE ENDWALL, 30", QUAD	EA	2	\$	\$
49	430 984 625	MITERED END SECTION, OPTIONAL - ELLIP/ARCH, 14" x 23"	EA	6	\$	\$
50	430 984 629	MITERED END SECTION, OPTIONAL - ELLIP/ARCH, 19"x 30"	EA	2	\$	\$
51	425	CONCRETE FLUME	EA	2	\$	\$
52	0425 11	MODIFY EXISTING DRAINAGE STRUCTURE (POND CONTROL)	EA	1	\$	\$
53	425	P-BOTTOM W/ 8" TOP SLAB	EA	1	\$	\$
					Drainage Sub-total	\$
Signing and Pavement Marking						
54	700 1 11	SINGLE POST SIGN, F&I GROUND MOUNT, UP TO 12 SF	EA	39	\$	\$
55	700 1 12	SINGLE POST SIGN, F&I GROUND MOUNT, 12-20 SF	EA	2	\$	\$
56	700 1 50	SINGLE POST SIGN, RELOCATE	EA	1	\$	\$

57	700 1 60	SINGLE POST SIGN, REMOVE	EA	17	\$	\$
58	706 1 3	RAISED PAVEMENT MARKER, TYPE B	EA	917	\$	\$
59	711 11 102	THERMOPLASTIC, STANDARD, WHITE, SOLID 8"	LF	437	\$	\$
60	711 11 123	THERMOPLASTIC, STANDARD, WHITE, SOLID 12"	LF	1,697	\$	\$
61	711 11 124	THERMOPLASTIC, STANDARD, WHITE, SOLID 18"	LF	513	\$	\$
62	711 11 125	THERMOPLASTIC, STANDARD, WHITE, SOLID 24"	LF	450	\$	\$
63	711 11 141	THERMOPLASTIC, STANDARD, WHITE, 2-4 DOTTED GUIDELINE, 6"	GM	0.51	\$	\$
64	711 11 160	THERMOPLASTIC, PREFORMED, WHITE, MESSAGE	EA	33	\$	\$
65	711 11 170	THERMOPLASTIC, PREFORMED, WHITE, ARROW	EA	101	\$	\$
66	711 11 224	THERMOPLASTIC, STANDARD, YELLOW, SOLID 18"	LF	170	\$	\$
67	711 15 101	THERMOPLASTIC, STANDARD OG ASPHALT, WHITE, SOLID, 6"	GM	3.77	\$	\$
68	711 15 131	THERMOPLASTIC, STANDARD OG ASPHALT, WHITE, SKIP, 6" 10-30 SKIP	GM	2.87	\$	\$
69	711 15 201	THERMOPLASTIC, STANDARD OG ASPHALT, YELLOW, SOLID, 6"	GM	2.05	\$	\$
			Signing and Marking Sub-Total			\$
		Total Lump Sum Bid Price	\$			

Exhibit "D" - Temporary Traffic Control Plan – Revised Per Addendum #2

As a bid alternate, contractor shall provide and construct a signed and sealed temporary traffic control plan, signed and sealed by a Florida Professional Engineer, that allows the contractor to build the CR 210 6-lane final condition with the following characteristics:

- The plan shall follow current Florida Department of Transportation (FDOT) Standard Specifications and Manual on Uniform Traffic Control Devices (MUTCD) criteria.
- The plan shall maintain 2 eastbound through lanes and 1 westbound through lane for the entire duration of construction until such time that two lanes in each direction can be fully opened and maintained.
- The plan is required to maintain a left turn movement at Cumberland Park Dr open for the eastbound and westbound directions for the duration of construction.
- Minimum lane width for the eastbound through lanes is 10', and 11' for the westbound through lane. Turn lane minimums are 10' in width.
- Impacts to wetlands outside the permitted wetland impact area identified in the St. Johns River Water Management District (SJRWMD) Permit shall not occur.
- Contractor shall not impact buried utilities during construction. Notification to UAO's required, 15 days in advance of proposed temporary roadway construction.
- Coordination required with associated signal project being installed at Cumberland Park Dr.
- Lane configuration plans specified in Phase I to be provided within 90 days of NTP.

EXHIBIT 'E' - CR 210 SIGNAL PLANS FOR COORDINATION & INFORMATION - REVISION PER ADDENDUM #2

TABULATION OF SIGNAL QUANTITIES

PAY ITEM NO.	DESCRIPTION	UNIT	SHEET NUMBERS						GRAND TOTAL
			1		2		3		
			PLAN	FINAL	PLAN	FINAL	PLAN	FINAL	
630-2-12	CONDUIT, F & T, DIRECTIONAL BORE	LF	425	2955				5232	
632-7-1	SIGNAL CABLE, NEW OR RECONSTRUCTED INTERSECTION, F & I	PI	1					5257	
633-1-121	FIBER OPTIC CABLE, FST, UNDERGROUND, 2-12 FIBERS	EA		3155		2102		24	
633-2-31	FIBER OPTIC CONNECTION, INSTALL, SPLICE	EA		12		12		24	
633-2-32	FIBER OPTIC CONNECTION, INSTALL, TERMINATION	EA		1		1		2	
633-3-11	FIBER OPTIC CONNECTION HARDWARE, FST, SPLICE ENCLOSURE	EA		1		1		2	
633-3-12	FIBER OPTIC CONNECTION HARDWARE, FST, BUFFER TUBE PAN OUT KIT	EA		1		1		2	
633-3-14	FIBER OPTIC CONNECTION HARDWARE, FST, BUFFER TUBE PAN OUT KIT	EA		1		1		2	
633-3-16	FIBER OPTIC CONNECTION HARDWARE, FST, PATCH PANEL FIBEL TERMINATED	EA		1		1		2	
633-3-20	FIBER OPTIC CONNECTION HARDWARE, FST, PATCH PANEL PATCH PANEL	EA		1		1		2	
633-5-1	BULL & SPLICE BOX, 6" X 13" X 14", COVER SIZE	EA	14					14	
633-5-12	BULL & SPLICE BOX, 6" X 13" X 14", COVER SIZE	EA		4				4	
630-1-12	ELECTRICAL SERVICE WIRE, F & T, OVERHEAD, METER PURCHASED BY CONTRACTOR FROM POWER COMPANY	EA	1					1	
630-2-11	ELECTRICAL SERVICE WIRE, F & T, OVERHEAD MOUNT	EA	100					100	
630-3-11	ELECTRICAL SERVICE DISCONNECT, F & T, POLE MOUNT	EA	1					1	
641-2-12	PRESTRESSED CONCRETE POLE, F & T, TYPE P-11, SERVICE POLE	EA	1					1	
646-1-11	ALUMINUM SIGNAL POLE, PEDESTAL	EA	8					8	
649-21-18	STEEL WAST ARM ASSEMBLY, F & T, DOUBLE ARM 70'-50'	EA	1					1	
649-21-19	STEEL WAST ARM ASSEMBLY, F & T, DOUBLE ARM 70'-60'	EA	1					1	
650-1-14	VEHICULAR TRAFFIC SIGNAL, F & T, ALUMINUM, 3 SECTION, 1 WAY	EA	12					12	
653-1-11	PEDESTRIAN SIGNAL, F & T LED COUNTDOWN, 1-WAY	EA	8					8	
660-4-11	VEHICLE DETECTION SYSTEM-VIDEO, F & T CABINET EQUIPMENT	EA	3					3	
660-4-12	VEHICLE DETECTION SYSTEM-VIDEO, F & T ABOVE GROUND EQUIPMENT	EA	8					8	
665-1-11	PEDESTRIAN DETECTOR, F & T, STANDARD	EA	1					1	
670-5-110	TRAFFIC CONTROLLER ASSEMBLY, F & T, NEMA	EA	2					2	
682-1-113	CCTV CAMERA, F & T, DOME PTZ, PRESSURIZED, 1P, HIGH DEFINITION	EA	1					1	
684-1-1	MANAGE FIELD ETHERNET SWITCH, LAYER 2, F & T	EA	1					1	
685-1-14	UNINTERRUPTIBLE POWER SUPPLY, F & T, ONLINE/DOUBLE CONVERSION WITH CABINET	EA	1					1	
700-5-21	INTERNALLY ILLUMINATED SIGN, F & T, OVERHEAD MOUNT, 12-18 SF	EA	4					4	
700-5-22	INTERNALLY ILLUMINATED SIGN, F & T, OVERHEAD MOUNT, 12-18 SF	EA	4					4	
715-5-32	LUMINAIRE & BRACKET ARM, GALV STEEL, F & T NEW LUMINAIRE AND ARM ON NEW EXISTING POLE	EA	2					2	

- PAY ITEM NOTES:
 682-1-113: PROVIDE TRAFFICWARE GRIDSMART SYSTEM PROCESSOR OR EQUIVALENT APPROVED BY MAINTAINING AGENCY.
 684-1-1: PROVIDE GRIDSMART GS SERIES VIDEO VEHICLE DETECTOR OR EQUIVALENT APPROVED BY MAINTAINING AGENCY.
 685-1-12: PROVIDE PELCO 2-HOLE SP-111-FL & 4-HOLE SP-1125-FL PASSPORT PIEZO PUSHBUTTON OR EQUIVALENT APPROVED BY MAINTAINING AGENCY.
 685-1-13: PROVIDE TRAFFICWARE COMMANDER ATC NEMA TS2 TYPE 2 CONTROLLER W/ TRAFFICWARE TS2 BIU-130 (BUS INTERFACE UNIT), & TRAFFICWARE TS2 CABINET POWER SUPPLY (PS2) IN TRAFFICWARE TS2 SIZE 6 W/ WIRE CABINET OR EQUIVALENT APPROVED BY MAINTAINING AGENCY.
 685-1-14: PROVIDE ITS EXPRESS BOX SECURITY SYSTEMS V65-ITS AUTODOME SERIES CAMERA OR EQUIVALENT APPROVED BY MAINTAINING AGENCY.
 685-1-14: PROVIDE TEMPLE FXM 2000 UNINTERRUPTIBLE POWER SUPPLY WITH CABINET OR EQUIVALENT APPROVED BY MAINTAINING AGENCY.
 700-5-AB: PROVIDE TCS Brilite TCSSIGNAL SERIES LED INTERNALLY ILLUMINATED SIGN OR EQUIVALENT APPROVED BY MAINTAINING AGENCY.
 715-5-32: PROVIDE AUTOBAHN (LED COBRAHEAD) ATB SERIES CONVENTIONAL LED LUMINAIRE OR EQUIVALENT APPROVED BY MAINTAINING AGENCY.

DATE	DESCRIPTION	REVISIONS	DATE	DESCRIPTION

 COUNTY ROAD 210 W
 WIDENING
 ST. JOHNS COUNTY, FLORIDA

PROSSER
 CIVIL ENGINEERING AND ARCHITECTURE
 1000 N. W. 11th St.
 Ft. Lauderdale, Florida 33304-2225
 www.prosserinc.com
 Phone: (954) 562-2225
 Fax: (954) 562-2225
 Lic. No. 15077
 Florida Civil and Architectural License No. 15077-00000500

SHEET NO. 135
 TABULATION OF QUANTITIES
 L:\NT\210\403 SIC CR 210 Widening\Project\Drawings\1301403-03\p135TAB501.dwg 2/27/02 2:58:52 PM

S.O.P. 7

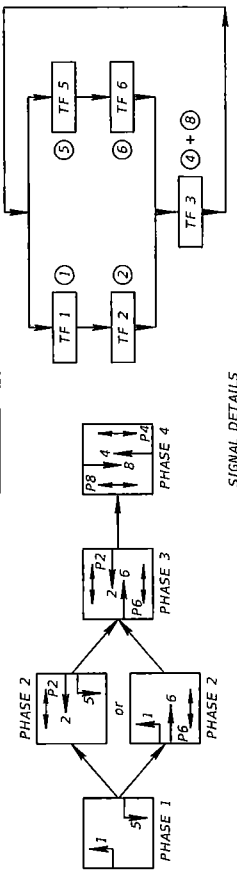

SIGNAL DETAILS

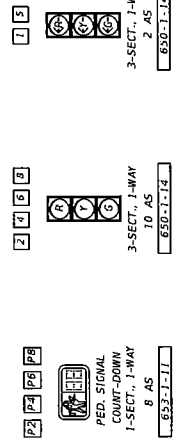

SIGNAL DETAILS

Cumberland Park Dr →

CR 210

Bager Park Dr →

Bager Park Dr ←

Cumberland Park Dr ←

DETECTOR	DETECTOR ZONE	DELAY TIME (SEC)
V02-1		0
V02-2		0
V02-5		0
V02-6		0
V02-7		0

DELAY TIME IS INITIAL AND MAY BE ADJUSTED AS DIRECTED BY PROJECT ENGINEER

TIMING FUNCTION	1	2	3	4	5	6	7	8
MOVEMENT NUMBER	1	2	3	4	5	6	7	8
MINIMUM GREEN	3.0	5.0	3.0	5.0	3.0	5.0	3.0	5.0
EXTENSION	2.0	2.0	2.0	2.0	2.0	2.0	2.0	2.0
MAXIMUM GREEN 1	120	160	45	120	160	45	120	160
MAXIMUM GREEN 2								
YELLOW CLEARANCE	3.4	4.0	3.7	3.4	4.0	3.7	3.4	4.0
ALL RED	3.3	2.0	2.3	3.3	2.0	2.3	3.3	2.0
PEDESTRIAN WALK	7.0	7.0	7.0	7.0	7.0	7.0	7.0	7.0
PEDE. CLEARANCE	12	31	12	31	12	31	12	31
RECALL								

TIMINGS ARE INITIAL AND MAY REQUIRE FIELD ADJUSTMENT AS DIRECTED BY THE ENGINEER.

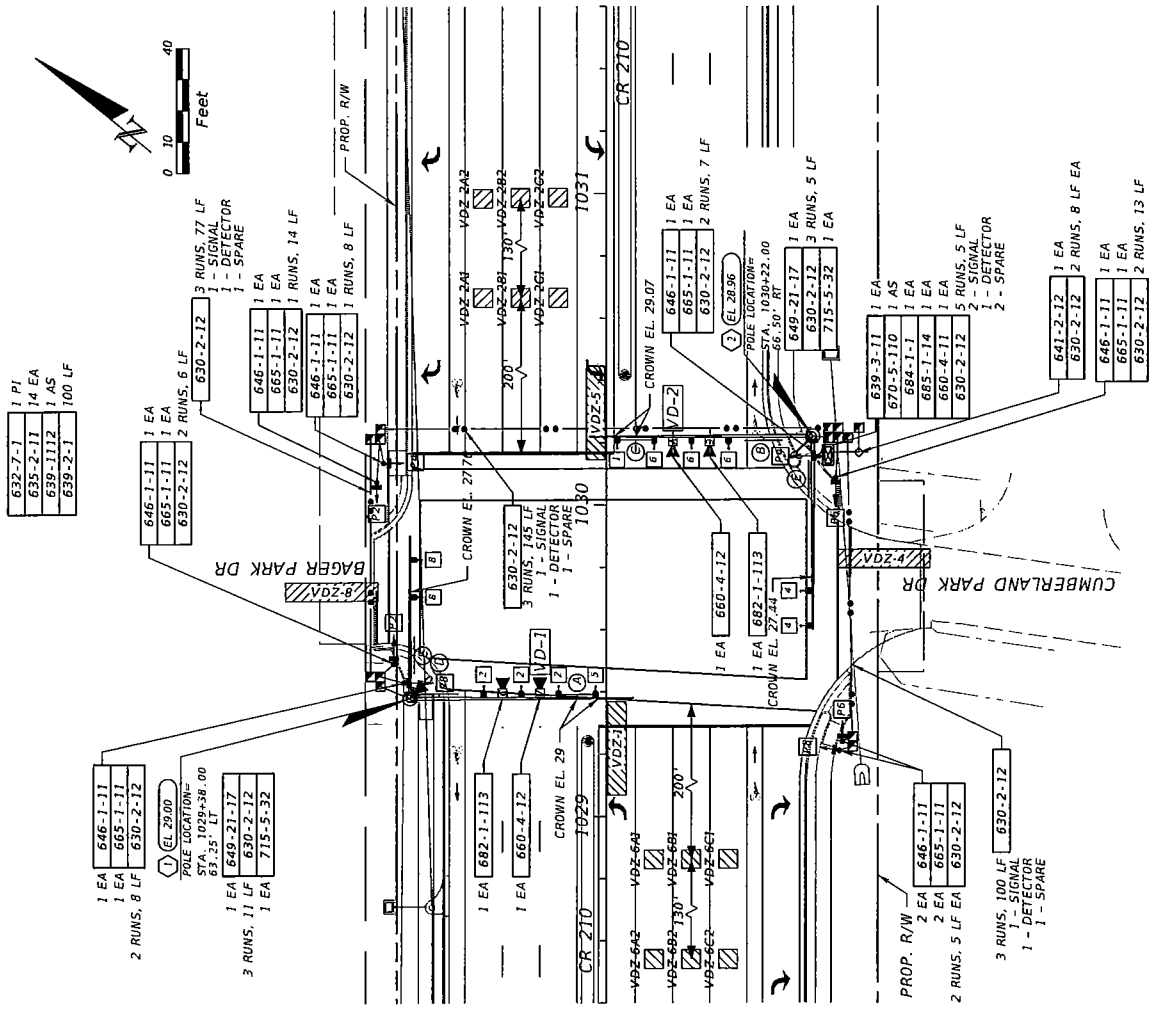
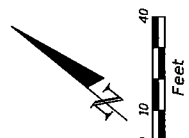

DATE	DESCRIPTION	REVISIONS	DATE	DESCRIPTION

PROSSER
CREATIVE SOLUTIONS, ENGINEERING AND
CONSTRUCTION

14507
www.prosser.com
888.888.8888
272.7823

COUNTY ROAD 210 W
WIDENING
ST. JOHNS COUNTY, FLORIDA

SIGNALIZATION PLAN

SHEET NO. 136

L:\NT\1107403 SIC CR 210 Widening\Production\Drawing\1107403-03-SP04A\PLAN0501.dwg

2/27/2013 3:56:54 PM



CONTRACTOR TO TIE NEW FOC TO EXIST. SIGNAL CONTROLLER AND/OR EXIST. FIBERS.

630-2-12	1 RUN @ 50 LF
633-1-121	12 FIBERS, 50 LF
633-2-31	12 EA
633-2-32	12 EA
633-3-11	1 EA
633-3-12	1 EA
633-3-14	1 EA
633-3-56	1 EA

DATE	DESCRIPTION	REVISIONS	DATE	DESCRIPTION

PROSSER
CREATIVE BUSINESS ENGINEERING, INC.
10400 W. US HWY 90, SUITE 200
FORT WORTH, TEXAS 76133-3238
www.prosserinc.com
CALL: 817.497.1497
FAX: 817.497.1498
Florida License # 12401 License # 00004938
7/27/2023

COUNTY ROAD 210 W
WIDENING
ST. JOHNS COUNTY, FLORIDA

INTERCONNECT DETAILS

SHEET NO. 137

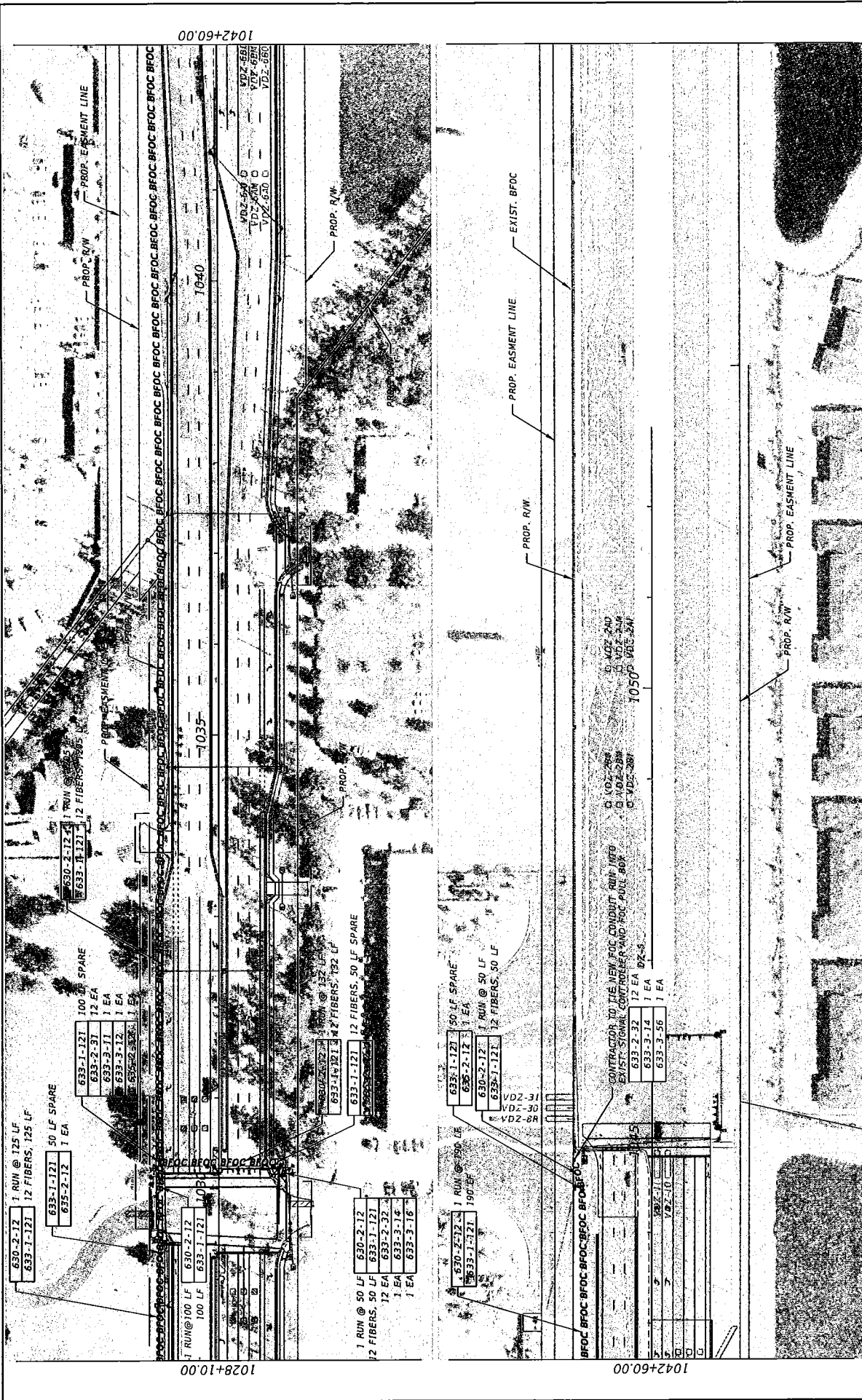

DATE	DESCRIPTION	REVISIONS	DATE	DESCRIPTION

<p>PROSSER CIVIL ENGINEERING & SURVEYING, INC. 10000 N. US HWY 1, SUITE 200 JACKSONVILLE, FLORIDA 32225-8225 WWW.PROSSERINC.COM PHONE: 904.743.3437 FAX: 904.743.3438</p>		<p>ST. JOHNS COUNTY, FLORIDA COUNTY ROAD 210 W WIDENING</p>	<p>INTERCONNECT DETAILS</p>
<p>7/17/2013</p>	<p>3:57:27 PM</p>	<p>ENJ131397403 516 CR 210 Widening Production Drawing\X113074-03\91615\PLW56102.dwg</p>	<p>SHEET NO. 138</p>

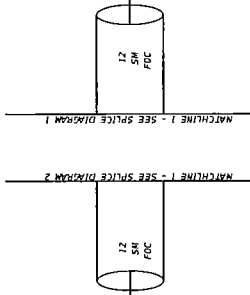
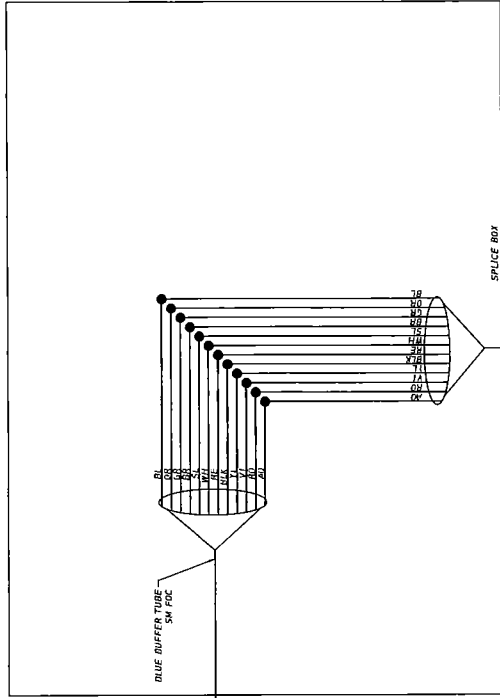

CR 210
FROM CE WILSON RD
TO BADGER PARK DR

SPLICE BOX

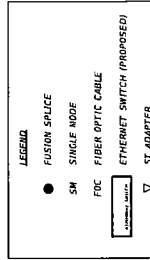
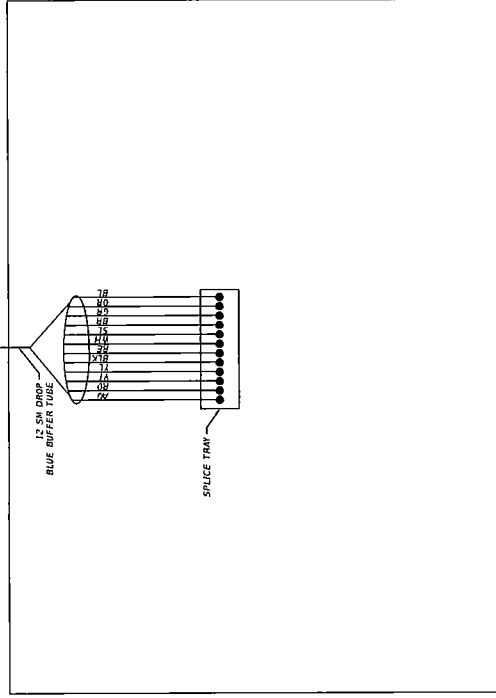

- NOTES:
1. CONTINUATION SHALL COMPLY WITH ALL APPLICABLE IEEE & OSHA REGULATIONS.
 2. ALL EXISTING FOC SPLICES OR TERMINATIONS SHALL REMAIN UNLESS SHOWN TO BE REMOVED IN PLANS.
 3. SPARE FIBERS AND UNUSED BUFFER TUBES SHALL BE COILED, LABELED, AND STORED NEATLY IN SPICE TRAY.

PROPOSED CABINET - BADGER
PARK DR
SPLICE DIAGRAM 2

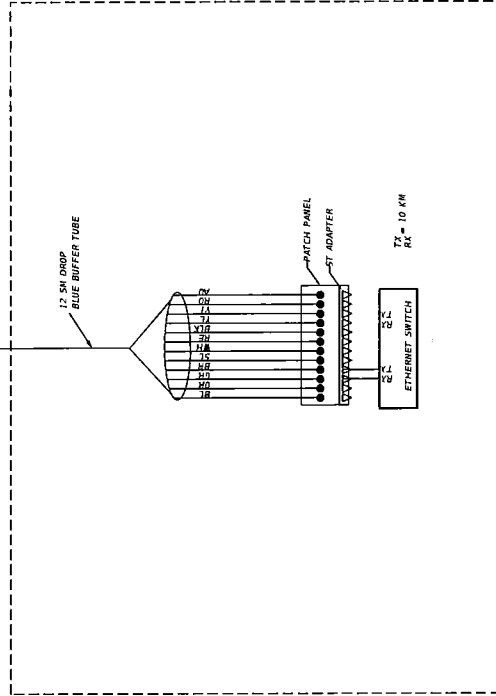
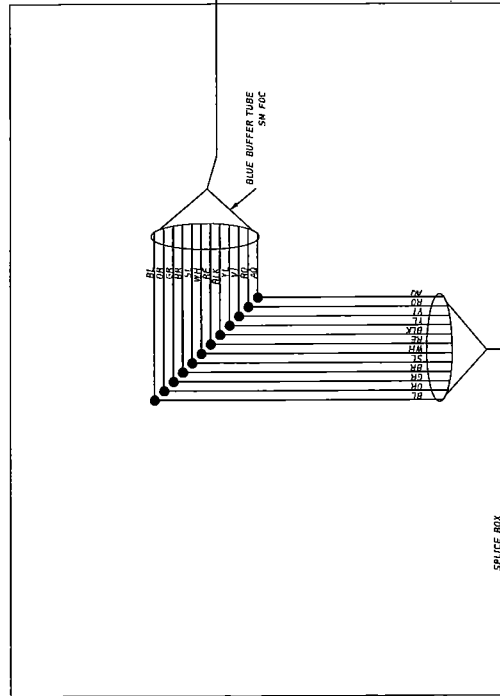

EXISTING CABINET -BADGER
PARK DR
SPLICE DIAGRAM 1

DATE	REVISIONS	DESCRIPTION

PROSSER
CONSTRUCTION SERVICES
1301 Wilson Park Drive, Suite 200
Jacksonville, FL 32216-3333
www.prosserinc.com
Phone: 904.725.3333
Fax: 904.725.3333

COUNTY ROAD 210 W
WIDENING
ST. JOHNS COUNTY, FLORIDA

SPLICE DIAGRAM

SHEET NO. 139

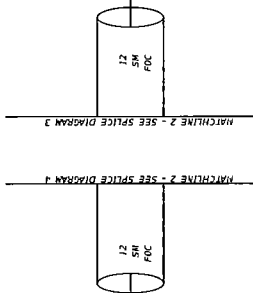
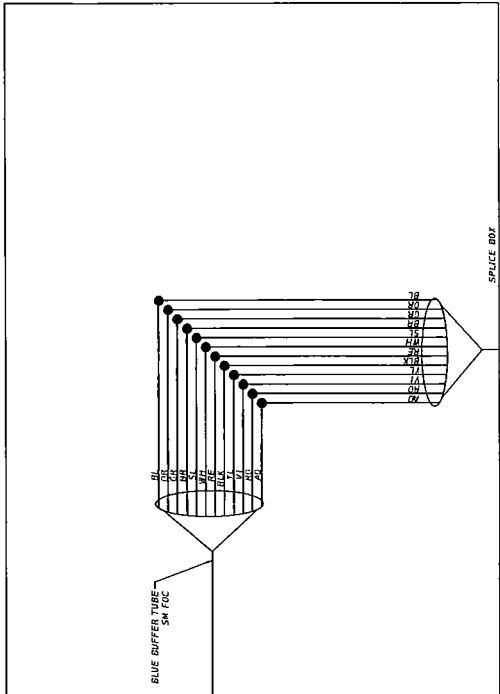
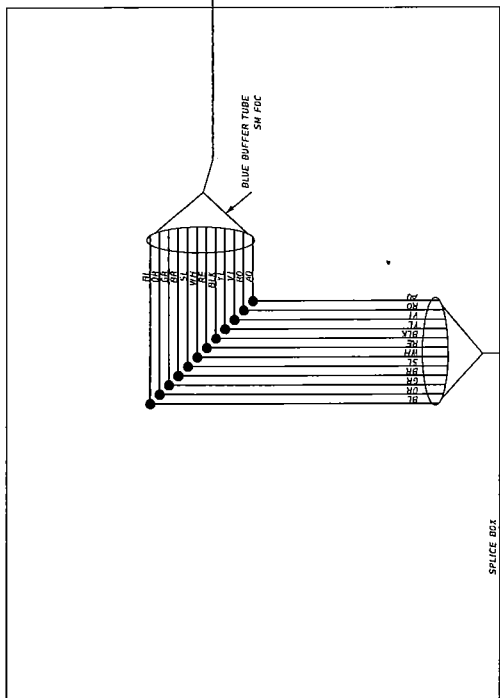

CR 210 FROM BADGER PARK DR TO BEACHWALK BLVD WESTERN

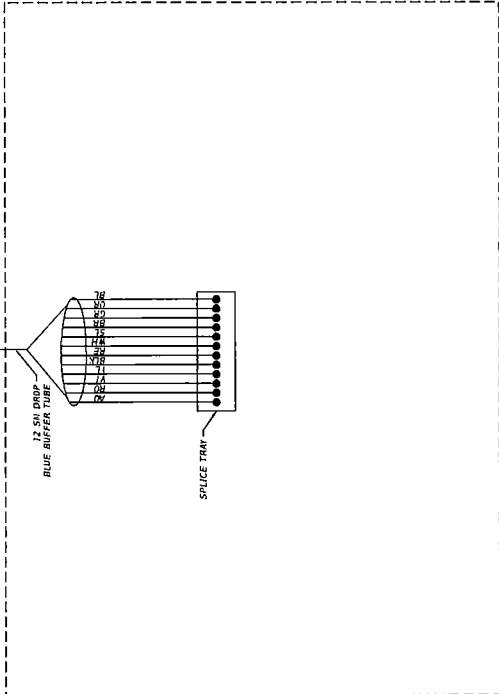
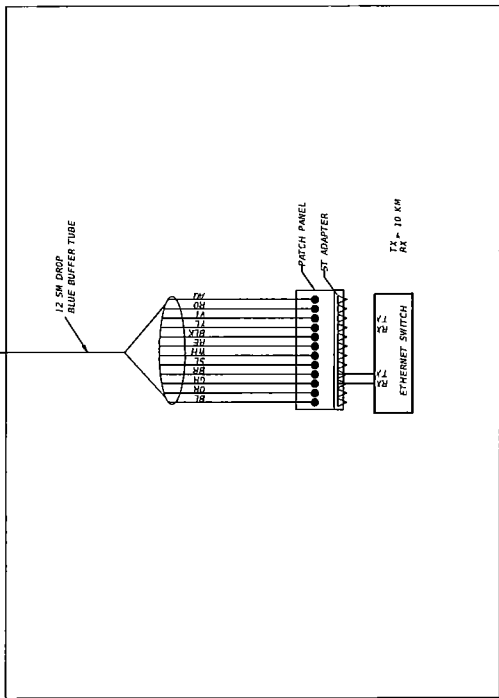

LEGENDA

- FUSION SPLICE
- SM SINGLE MODE
- FOC FIBER OPTIC CABLE
- ETHERNET SWITCH (PROPOSED)
- ST ADAPTER

- NOTES:**
1. CONTRACTOR SHALL COMPLY WITH ALL APPLICABLE IEEE & ANSI REGULATIONS.
 2. ALL EXISTING FOC SPLICES OR TERMINATIONS SHALL REMAIN UNLESS SHOWN TO BE REMOVED IN PLANS.
 3. SPARE FIBERS AND UNUSED BUFFER TUBES SHALL BE COILED, LABELED, AND STORED NEATLY IN SPLICED TRAY.

PROPOSED CABINET - BADGER
PARK DR SPLICE DIAGRAM 3

EXISTING CABINET - BEACHWALK
BLVD WESTERN
SPLICE DIAGRAM 4

REVISIONS	DATE	DESCRIPTION

PROSSER ENGINEERING PLAINS
CREATIVE VISIONARIES. ENGINEERING PLAINS
10010 UNIVERSITY DRIVE, SUITE 200
PLAINS, TEXAS 75075-3228
WWW.PROSSERENGINEERING.COM
PHONE: (972) 393-3228
FAX: (972) 393-3228

COUNTY ROAD 210 W
WIDENING
ST. JOHNS COUNTY, FLORIDA

SPLICE DIAGRAM

SHEET NO. 140

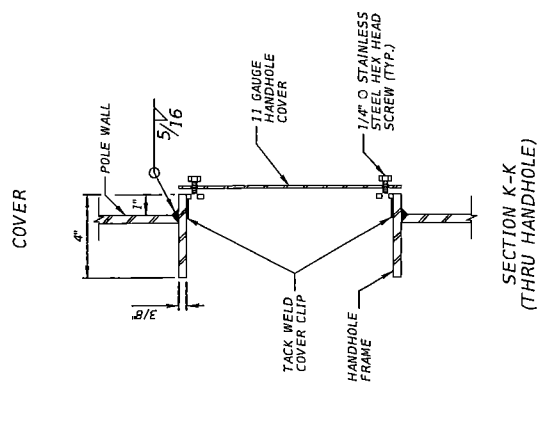
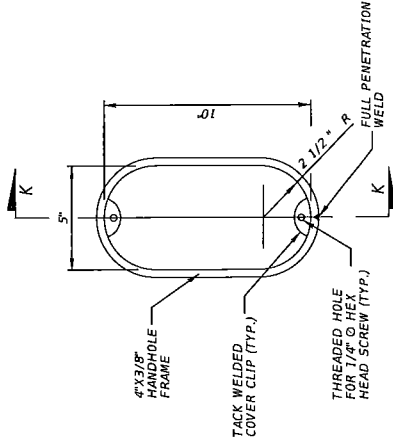
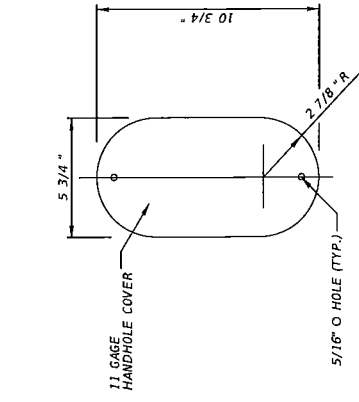

SECTION K-K
(THRU HANDHOLE)

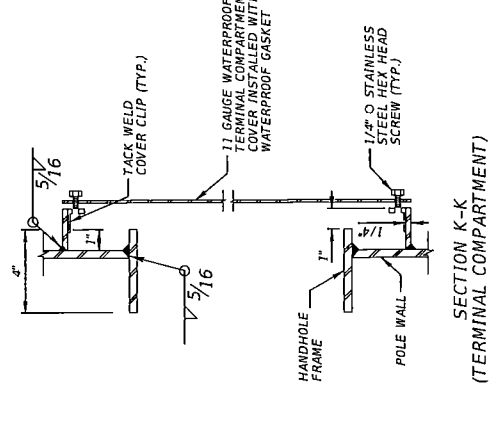

HANDHOLE
N.T.S

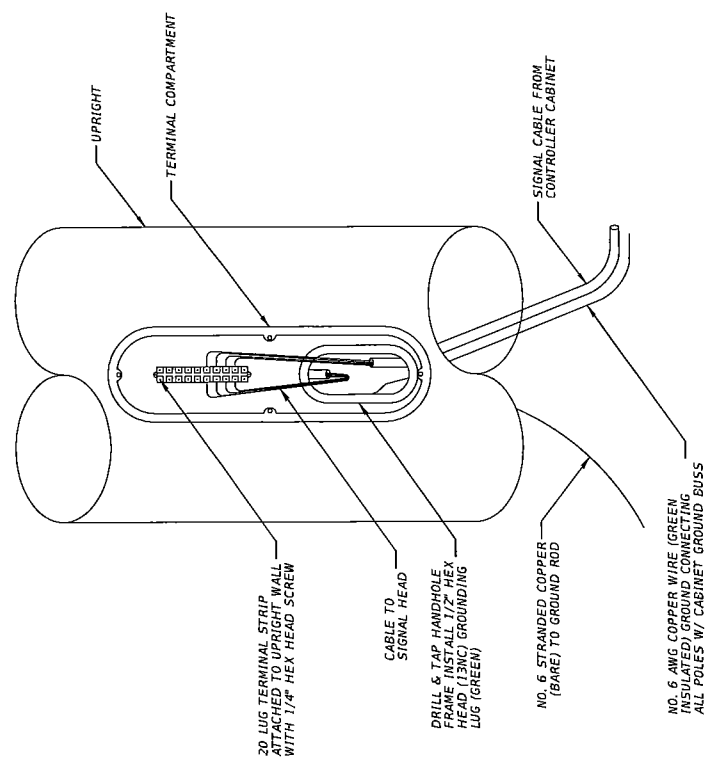

TERMINAL COMPARTMENT WIRING DETAILS
N.T.S

DATE	DESCRIPTION	REVISIONS	DATE	DESCRIPTION

PROSSER
 CIVIL ENGINEERING
 10000 N. W. 11th St., Suite 100
 Jacksonville, Florida 32213-2525
 www.prosser.com
 Phone: 904.253.1400
 Fax: 904.253.1401
 Florida License # 14007
 State of Florida
 7/27/02

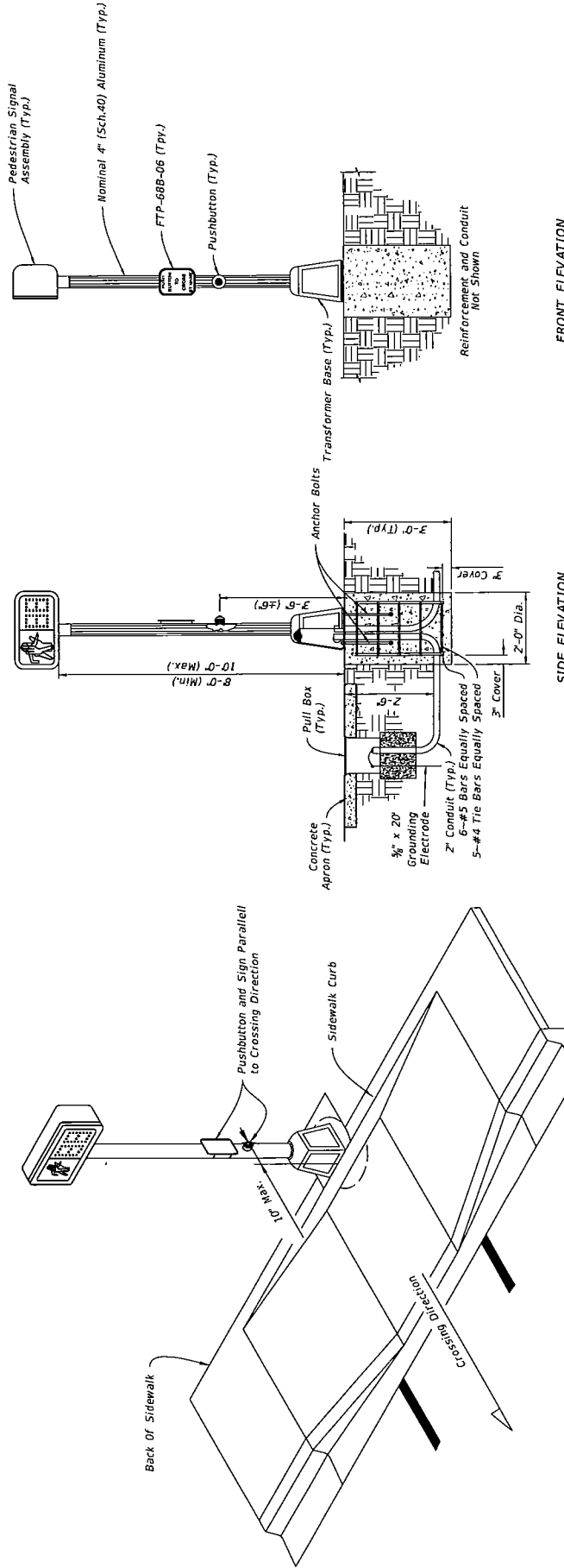

 COUNTY ROAD 210 W
 WIDENING
 ST. JOHNS COUNTY, FLORIDA

SHEET NO. 141



PEDESTRIAN SIGNAL PEDESTAL DETAIL

DATE	DESCRIPTION	REVISIONS	DATE	DESCRIPTION

		COUNTY ROAD 210 W WIDENING ST. JOHNS COUNTY, FLORIDA	SIGNALIZATION DETAILS SHEET NO. 142
--------------------------------------------------------------------------------------	--	------------------------------------------------------------	-----------------------------------------------

PROSSER CREATIVE SOLUTIONS, ENGINEERING AND ARCHITECTURE 10000 International Parkway, Suite 200 Jacksonville, Florida 32226-3326 www.prosserinc.com 904.725.1100		3:57:30 PM EN17A113074.DWG SJC CR 210 Widening Production Drawing S113074-03 SUPPLIERS PEDESTAL DETAILS.dgn 2/27/2023 In: rcm010112
----------------------------------------------------------------------------------------------------------------------------------------------------------------------------------------	--	----------------------------------------------------------------------------------------------------------------------------------------------

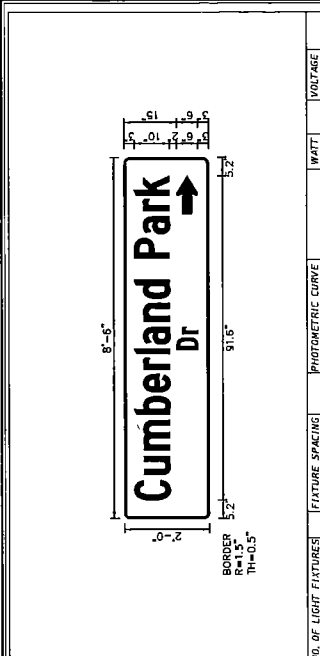

SIGN NAME	Sign A	QTY	STATIONS
PANEL	BORDER		none
WIDTH	8'-5"	WIDTH	0.5'
HEIGHT	2'-0"	RADIUS	1.5"
LEGEND	White	COLOR	White
COLOR	Green		
SYMBOL(S)	ANGLE	X	Y
Arrow Custom	90	5.2	3
		6	10.7

NO. OF LIGHT FIXTURES	FIXTURE SPACING	PHOTOMETRIC CURVE	WATT	VOLTAGE											
COPY	5.2	19.4	28.5	35.8	42.2	48.6	48.3	55.8	62.3	67.4	73.6	80.5	87	91.4	91.6
SPACE	47.8	52.2	6.4												

SIGN NAME	Sign C	QTY	STATIONS
PANEL	BORDER		none
WIDTH	8'-5"	WIDTH	0.5'
HEIGHT	2'-0"	RADIUS	1.5"
LEGEND	White	COLOR	White
COLOR	Green		
SYMBOL(S)	ANGLE	X	Y
Arrow Custom	90	5.2	3
		6	10.7

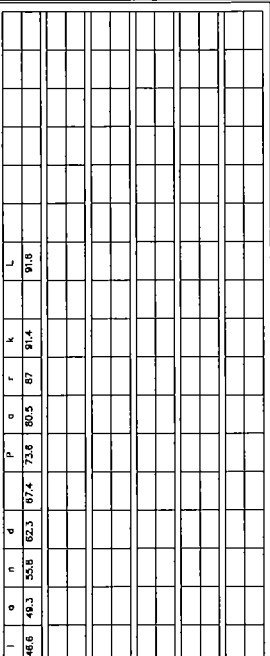

SIGN NAME	Sign B	QTY	STATIONS
PANEL	BORDER		none
WIDTH	8'-5"	WIDTH	0.5'
HEIGHT	2'-0"	RADIUS	1.5"
LEGEND	White	COLOR	White
COLOR	Green		
SYMBOL(S)	ANGLE	X	Y
Arrow Custom	270	66.1	3
		6	10.7

NO. OF LIGHT FIXTURES	FIXTURE SPACING	PHOTOMETRIC CURVE	WATT	VOLTAGE											
COPY	5.2	19.4	28.5	35.8	42.2	48.6	48.3	55.8	62.3	67.4	73.6	80.5	87	91.4	91.6
SPACE	47.8	52.2	6.4												

SIGN NAME	Sign D	QTY	STATIONS
PANEL	BORDER		none
WIDTH	8'-5"	WIDTH	0.5'
HEIGHT	2'-0"	RADIUS	1.5"
LEGEND	White	COLOR	White
COLOR	Green		
SYMBOL(S)	ANGLE	X	Y
Arrow Custom	90	6.7	3
		6	10.7

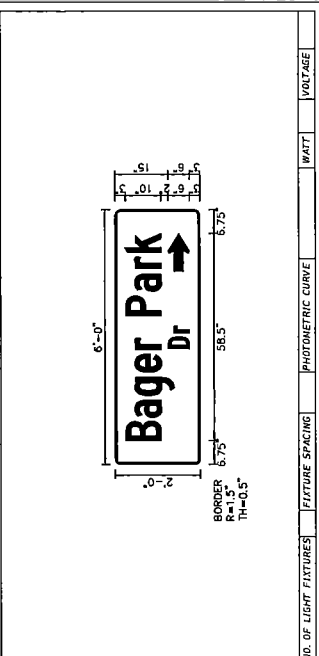

SIGN NAME	Sign A	QTY	STATIONS
PANEL	BORDER		none
WIDTH	6'-0"	WIDTH	0.5'
HEIGHT	2'-0"	RADIUS	1.5"
LEGEND	White	COLOR	White
COLOR	Green		
SYMBOL(S)	ANGLE	X	Y
Arrow Custom	270	54.8	3
		6	10.7

NO. OF LIGHT FIXTURES	FIXTURE SPACING	PHOTOMETRIC CURVE	WATT	VOLTAGE											
COPY	6.7	13.3	18.5	26.1	32.5	35.8	42.1	49	55.5	59.9	58.5				
SPACE	32.8	37.2	6.4												

SIGN NAME	Sign C	QTY	STATIONS
PANEL	BORDER		none
WIDTH	6'-0"	WIDTH	0.5'
HEIGHT	2'-0"	RADIUS	1.5"
LEGEND	White	COLOR	White
COLOR	Green		
SYMBOL(S)	ANGLE	X	Y
Arrow Custom	90	6.7	3
		6	10.7

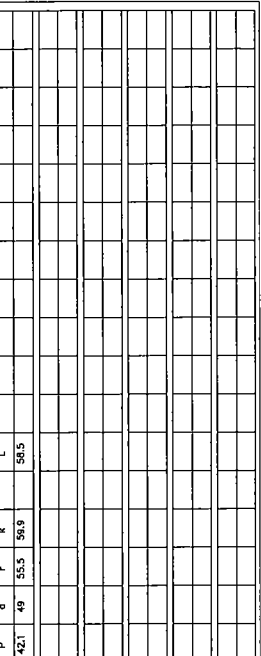

SIGN NAME	Sign B	QTY	STATIONS
PANEL	BORDER		none
WIDTH	6'-0"	WIDTH	0.5'
HEIGHT	2'-0"	RADIUS	1.5"
LEGEND	White	COLOR	White
COLOR	Green		
SYMBOL(S)	ANGLE	X	Y
Arrow Custom	270	54.8	3
		6	10.7

NO. OF LIGHT FIXTURES	FIXTURE SPACING	PHOTOMETRIC CURVE	WATT	VOLTAGE											
COPY	6.7	13.3	18.5	26.1	32.5	35.8	42.1	49	55.5	59.9	58.5				
SPACE	32.8	37.2	6.4												

SIGN NAME	Sign D	QTY	STATIONS
PANEL	BORDER		none
WIDTH	6'-0"	WIDTH	0.5'
HEIGHT	2'-0"	RADIUS	1.5"
LEGEND	White	COLOR	White
COLOR	Green		
SYMBOL(S)	ANGLE	X	Y
Arrow Custom	90	6.7	3
		6	10.7

PROSSER
 COUNTY ROAD 210 W
 WIDENING
 ST. JOHNS COUNTY, FLORIDA

DATE: _____ DESCRIPTION: _____
 REVISIONS: _____ DATE: _____ DESCRIPTION: _____

DATE: _____ DESCRIPTION: _____
 REVISIONS: _____ DATE: _____ DESCRIPTION: _____

SHEET NO. 143
 GUIDESIGN WORKSHEET

SIGN NAME	Sign E	QTY	1	WORK STATION(S)	
PANEL	BORDER	WIDTH	15.0"		
HEIGHT	2'-0"	RADIUS	1.5"		
LEGEND	White	COLOR	White		
Symbols	ANGLE	X	Y	WID	HT
Symbol 1					
Symbol 2					

NO. OF LIGHT FIXTURES		FUTURE SPACING		PART	
REFERENCE					
BY					
DATE					

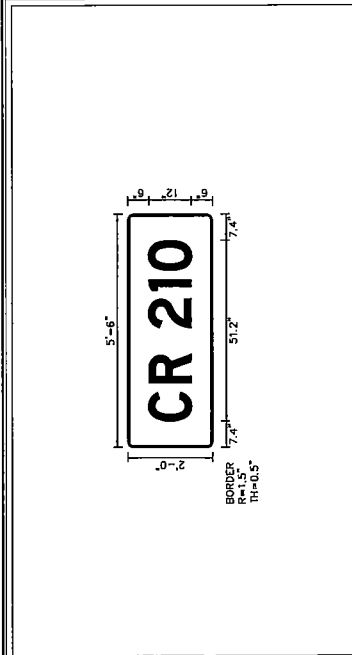

NO. OF LIGHT FIXTURES		FUTURE SPACING		PART	
REFERENCE					
BY					
DATE					

WORK STATION(S)	QTY	TYPE	DESCRIPTION	DATE
	1	COPY	SPACE	
	1	COPY	SPACE	
	1	COPY	SPACE	
	1	COPY	SPACE	
	1	COPY	SPACE	
	1	COPY	SPACE	
	1	COPY	SPACE	
	1	COPY	SPACE	
	1	COPY	SPACE	
	1	COPY	SPACE	
	1	COPY	SPACE	
	1	COPY	SPACE	
	1	COPY	SPACE	
	1	COPY	SPACE	
	1	COPY	SPACE	
	1	COPY	SPACE	
	1	COPY	SPACE	
	1	COPY	SPACE	
	1	COPY	SPACE	
	1	COPY	SPACE	
	1	COPY	SPACE	
	1	COPY	SPACE	
	1	COPY	SPACE	
	1	COPY	SPACE	
	1	COPY	SPACE	
	1	COPY	SPACE	
	1	COPY	SPACE	
	1	COPY	SPACE	

WORK STATION(S)	QTY	TYPE	DESCRIPTION	DATE
	1	COPY	SPACE	
	1	COPY	SPACE	
	1	COPY	SPACE	
	1	COPY	SPACE	
	1	COPY	SPACE	
	1	COPY	SPACE	
	1	COPY	SPACE	
	1	COPY	SPACE	
	1	COPY	SPACE	
	1	COPY	SPACE	
	1	COPY	SPACE	
	1	COPY	SPACE	
	1	COPY	SPACE	
	1	COPY	SPACE	
	1	COPY	SPACE	
	1	COPY	SPACE	
	1	COPY	SPACE	
	1	COPY	SPACE	
	1	COPY	SPACE	
	1	COPY	SPACE	
	1	COPY	SPACE	
	1	COPY	SPACE	
	1	COPY	SPACE	
	1	COPY	SPACE	
	1	COPY	SPACE	

COUNTY ROAD 210 W
WIDENING
ST. JOHNS COUNTY, FLORIDA

GUIDESIGN WORKSHEET

SHEET NO. 144

DATE: _____ DESCRIPTION: _____

REVISIONS: _____

PROSSER
CORPORATION
4941 South U.S. Highway 90A, Suite 500
Jacksonville, Florida 32218
904.251.1322
www.prosserinc.com 800.905.8009
Florida Certificate of Authorization Number: 00000003

ARM NO. 2 - DOUBLE ARM POLE ORIENTATION TO BE MEASURED IN A COUNTER CLOCKWISE DIRECTION FROM ARM NO. 1.

ARM NO. 1 - SINGLE ARM POLE OR LONGEST ARM FOR DOUBLE ARM POLE.

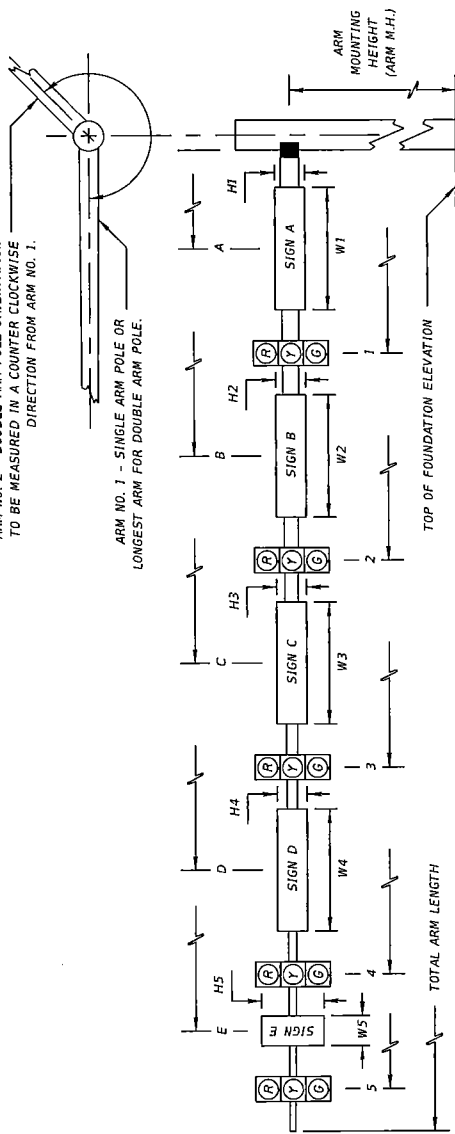

SPECIAL INSTRUCTIONS			
ID NO.	RED. BUTTON	RED. SIGNALS	HANDHOLE LOCATION

* DENOTES NUMBER OF SECTIONS IN SIGNAL HEAD ASSEMBLY

SIGNAL DATA																						
ID	SHEET NO.	LOCATION BY STA.	TOP OF ELEVATION	ARM NO.	CROWN ELEV.	LIMIT H/W/H	TERM. V/H	SIGNAL V/H	FACE OF SIGNAL	PED. V/H	DISTANCE FROM POLE					TOTAL LENGTH	ARM BETWEEN M.H.	ANGLE BETWEEN				
											1	2	3	4	5							
1		1029+38.00	28.27	1	29.00			V	Y	N	23.8	3	35.8	3	47.8	3	59.8	3	70	20.5	90	
				2	27.76			V	Y	N	32.6	3	44.6	3					50		-----	
2		1030+22.00	28.34	1	29.07			V	Y	N	27.0	3	39.0	3	51.0	3	63.0	3	70	20.5	90	
				2	27.44			V	Y	N	19.1	3	39.1	3					60		-----	

** FREE-SWINGING, INTERNALLY ILLUMINATED STREET SIGN.

SIGN DATA																					
ID	SHEET NO.	LOCATION BY STA.	TOP OF ELEVATION	ARM NO.	CROWN ELEV.	LIMIT H/W/H	TERM. V/H	SIGNAL V/H	FACE OF SIGNAL	PED. V/H	DISTANCE FROM POLE / HEIGHT AND WIDTH OF SIGN										PAINT COLOR
											A*	H1	W1	B	H2	W2	C	H3	W3	D	
1		1029+38.00	28.27	1	29.00			V	Y	N	14	2	6	29.8	DZ1	41.8	CCTV	53.8	2	8.5	
				2	27.76			V	Y	N	13.8	2	5.5								
2		1030+22.00	28.34	1	29.07			V	Y	N	15.3	2	8.5	33.0	DZ2	45.0	CCTV	57.0	2	6	
				2	27.44			V	Y	N	13.8	2	5.5								

PROSSER
 COUNTY ROAD 210 WIDENING
 ST. JOHNS COUNTY, FLORIDA
 2/23/2023

STANDARD MAST ARM TABULATION

Table Date 01-01-12

SPECIAL MAST ARM ASSEMBLIES DATA TABLE

NUMBER OF LOCATIONS	STRUCTURE NUMBER	FIRST ARM			FIRST ARM EXTENSION			SECOND ARM			SECOND ARM EXTENSION			POLE										
		FA(ft)	FB(in)	FC(in)	FD(in)	FE(ft)	FF(in)	FG(in)	FA(ft)	SB(in)	SC(in)	SD(in)	SE(ft)	SF(in)	SH(in)	UA(ft)	UB(ft)	UC(in)	UD(in)	UE(in)	UF(deg)	UG(ft)		
1	1	38	7.68	13	0.25	35	12.1	17	0.5	32.5	7.45	12	0.25	20	11.2	14	0.313	24	21	20.7	24	0.375	90	0
1	2	38	7.68	13	0.25	35	12.1	17	0.5	35.5	7.03	12	0.25	27.5	11.2	15	0.375	24	21	20.7	24	0.5	90	0

Table Date 01-01-12

SPECIAL MAST ARM ASSEMBLIES DATA TABLE (CONT.)

STRUCTURE NUMBER	#Boils	FIRST ARM CONNECTION (in)			FIRST Arm Camber Angle = 2 Degrees			SECOND ARM CONNECTION (in)			Second Arm Camber Angle = 2 Degrees											
		HT	FL	FK	FN	FO	FP	FR	FS	FT	#Boils	HT	SJ	SK	SL	SN	SO	SP	SR	SS	ST	
1	6	30	36	3	0.75	23	1.25	2	12.5	0.375	6	30	36	3	0.75	0.187	23	1.25	2	12.5	0.25	
2	6	30	36	3	0.75	23	1.25	2	12.5	0.375	6	30	36	3	0.75	0.187	23	1.25	2	12.5	0.25	

CONSTRUCTION CONSIDERATIONS:
 "TEMPORARY CASING SHALL BE ANTICIPATED TO BE USED WHERE VERY LOOSE SOILS ARE ENCOUNTERED. IF DEEMED NECESSARY, THE TEMPORARY CASING SHALL EXTEND BELOW THE DEPTH OF THE VERY LOOSE SOILS"

Table Date 07-01-15

SPECIAL MAST ARM ASSEMBLIES DATA TABLE (CONT.)

STRUCTURE NUMBER	#Boils	POLE BASE CONNECTION (in)			SHAFT AND REINF.			LUMINAIRE AND LUMINAIRE CONNECTION																	
		BA	BB	BC	BF	DA(ft)	DB(ft)	RA	RB	RC	RD(in)	RE	RF(in)	LA(ft)	LB(ft)	LC(in)	LD(in)	LE	LF(ft)	LG(in)	LH(in)	LJ(in)	LK(in)	LL(deg)	
1	8	40	2.5	2	40	21	5	11	19	10	6	10	9	0	0	0	0	0	0	0	0	0	0	0	0
2	8	40	2.5	2	40	21	5	11	19	10	6	10	9	0	0	0	0	0	0	0	0	0	0	0	0

NOTES (Notes Date 07-01-13):
 1. Work with Index 649-031.
 2. Design Wind Speed = 150 mph

FOUNDATION NOTES (Notes Date 01-01-12):
 1. Design based on Borings taken sealed by John A. Iya, P.E. of Civil Services, Inc.
 2. Assumptions and Values used in design:
 Soil Type FINE SAND
 Soil Layer Thickness = 20 ft.
 Soil Friction Angle = 31 deg.
 Soil Weight = 109 pcf
 Design Water Table is 0 ft. below surface

		COUNTY ROAD 210 W WIDENING ST. JOHNS COUNTY, FLORIDA	SPECIAL MAST ARM ASSEMBLIES DATA TABLE
REVISIONS DATE DESCRIPTION			
STATES STINES FILES			
SHEET NO.			



ADDENDUM #1

September 28, 2023

To: Prospective Bidders
From: St. Johns County Purchasing Division
Subject: Bid No: 23-94 CR 210 Widening from Trinity Way to Beachwalk Boulevard

This Addendum #1 is issued for further Bidders' information, and is hereby incorporated into the BID Documents. Each Bidder must incorporate any and all revisions, clarifications, and/or supplemental information provided in all issued addenda with the submitted Bid. Bidders must submit a copy of each signed addendum with their Bid as provided in the Bid Documents.

Revisions/Clarifications:

The County provides the following revisions and/or clarifications to be incorporated into the Bid Documents:

1. Replace Table of Contents page 2 of the Bid Document and replace with same page contained in this Addendum.
2. Remove the Official County Bid Form pages 18 and 19 and replace with the same pages contained in this Addendum.
3. Remove Attachment "P" – Schedule of Values – Eighteen (18) Months Completion Time and replace with Revised Attachment "P" – Revised Schedule of Values – Eighteen (18) Months Completion Time contained in this Addendum.
4. Remove Attachment "Q" – Schedule of Values – Fifteen (15) Months Completion Time.
5. Replace Exhibit "A" CR 210 Widening Construction Plans – Dated February 23, 2023 with Revised Exhibit "A" CR 210 Widening Construction Plans – Dated September 2023.
6. Computer Aided Design files have been placed on the St. Johns County Public Works website and can be accessed by clicking the link below and entering the User Name and Password listed below:

Link: [St. Johns County Public Works Website](#)

User Name: Pubworksanon

Password: sjcpubworks

All files can be accessed in the **CR 210 Widening (Twin Creeks)** file folder.

7. Due to the scope and size of this project, the Bid Opening initially scheduled for Wednesday, 2:00 PM on October 11, 2023 is hereby changed to Wednesday, 2:00 PM on October 18, 2023.

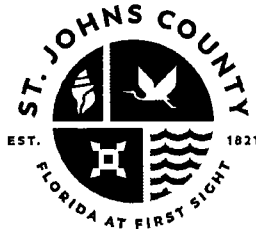

Questions/Answers:

The County provides the following answers to the questions submitted below:

1. Following the installation & inspection criteria set forth in FDOT's "Standard Specifications for Road and Bridge Construction", may FDOT approved Class II Polypropylene Pipe be used on this project as an alternate storm drainage material?

Answer: No. Per plans sheet 18, note 27, all storm pipe shall be Reinforced Concrete Pipe.

2. Will bidder be required to be either FL CGC or FL CUC, or will bidder be required to hold both certifications?

Answer: Contractor must have either or FL CGC or FL CUC certifications.

3. What warranty period will be required? SJC is typically 26 months, FDOT is 24 months, some projects 12 months.

Answer: Contractor warrants all materials, equipment and labor it furnishes or performs under this Contract against all defects in design, materials and workmanship for a period of one year (or the period of time in any guarantee or warranty provided by any manufacturer or supplier of equipment or materials incorporated into the Work, whichever is later) from and after the date of Final Completion.

4. Please define the funding source for the project.

Answer: County Capital Funds

5. Who will be responsible for utility relocation, including any required coordination, design, permits or fees?

Answer: Utility relocations will be completed by the responsible utility company. Coordination between the contractor and the utility companies will be necessary. Any design work for relocations will be completed by the responsible utility company. No requirements for permitting are expected or currently required.

6. I notice signal plans within this project, I have also noticed that a previous project was out for bid involving the same signal location, how is this going to be coordinated?

Answer: The signal plans for this this project is being completed under a separate contract (Bid No. 23-84). The Signal Project Contractor will be invited to attend pre-construction and progress meetings to aid in coordination between these two projects.

7. On sheet 25 showing installation of 54" pipe to a pond? Sheet 53 shows existing 42" to remain which is correct?

Answer: The 42" is to remain with no 54" to be constructed. (Please see Exhibit "A" Sept. 2023)

8. All typical sections show SP-9.5 for final lift of asphalt. Attachment "P" of the bidding documents shows FC-9.5, TL-B, PG 76-22 (Line 13). Please advise correct mix type?

Answer: Per County Standard, SP 9.5 is acceptable asphalt. (Please see Revised Attachment "P".)



9. Current FDOT Specifications govern per contract plans. Specially, please advise if section 9-2.1.2 Bituminous Material is applicable to this contract?

Answer: FDOT Design Build Specifications Div. 1 – Sect. 9-2.1.2 is not applicable for this project.

10. Sheet 25 calls out to construct 324 LF of 54" Pipe from Structure S-730A. Sheet 53 calls out Structure S-730B in the location of Structure S-730A and shows Existing 42" Pipe (To Remain). Is Structure S-730B supposed to be Structure S-730A and is the 42" Pipe to remain or is the 54" Pipe to be constructed? 54" Pipe is not included in the bid form.

Answer: The 42" is to remain with no 54" to be constructed. Structure reference should be 730A. Disregard 54" pipe. (Please see Exhibit "A" Sept. 2023)

11. Sheet 22 calls out to construct Pedestrian Railing on both sides of the roadway. Pedestrian Railing is not included in the bid form. Is the Pedestrian Railing to be constructed and what type of railing should be installed?

Answer: Proposed railing is to be Aluminum Ped/Bike Railing per FDOT index 515-062. (Please see Exhibit "A" Sept. 2023)

12. Sheet 135 shows a Tabulation of Signal Quantities. The Signal Quantities are not included in the bid form. Will a new bid form be issued to include the Signal Quantities?

Answer: Please refer to question #6.

13. Sheet 53 calls out CS-1A Control Structure to be modified. What bid item does this modification fall under? Should this modification be added to the bid form?

Answer: Template is not all inclusive and can be modified based on contractors bid estimate. (Please see Revised Attachment "P".)

14. Can the bid form be provided in Excel format?

Answer: No.

15. It is stated that bidders must be licensed in Pavement Markings. Can the Pavement Markings be performed by a subcontractor?

Answer: Yes. Contractors and Sub-Contractors must be appropriately licensed for the work being performed.

16. What, if any, is the retainage for the project?

Answer: Retainage is at 5% until final acceptance of all work.

17. Will all of the mobilization be paid at the beginning of the project?

Answer: Mobilization payout will be dependent upon contractor invoice submittals.

18. How will rain days be handled during construction?

Answer: Utilizing appropriate Storm Water Pollution Prevention Plan (SWPPP) reports/documentation, weather event days will be reviewed for granting additional time for final completion.



19. What holidays are observed throughout the year during construction?

Answer: The following holidays are recognized St. Johns County: New Year's, Martin Luther King Jr. Day, President's Day, Good Friday, Memorial Day, Independence Day, Labor Day, Veteran's Day, Thanksgiving (2 days) and Christmas (2 days).

20. How will fuel be handled throughout construction? FDOT fuel standards?

Answer: The County does not utilize fuel standards. All fuel concerns should be built into the bid, as this project will be a lump sum project.

21. Is any builders risk required for the bid?

Answer: No.

22. On the Schedule of Values, there are no Pay Items for the Maintenance of Traffic. Please provide applicable bid items and quantities for Commercial Material for Driveway Maintenance, Pedestrian or Bicycle Special Detour, Traffic Control Officer, Work Zone Signs, Business Signs, Arrow Board, Temporary Raised Pavement Markers, Portable Changeable Message Sign, Temporary Signalization and Maintenance, Temporary Traffic Detection and Maintenance, Type III Barricade, Portable Regulatory Sign, Painted Pavement Markings and Temporary Striping.

Answer: Maintenance of Traffic has been added. (Please see Revised Attachment "P".)

23. Will temporary pavement, temporary drainage, temporary embankment, temporary striping, temporary signs and temporary grassing be required to safely facilitate the movement of traffic across the construction phasing limits? Will you update the MOT plans to show the above items?

Answer: Please refer to question #22.

24. The are no Schedule of Values for the Signalization. Can you please provide?

Answer: Please refer to question #6.

SUBMITTAL DEADLINE FOR BIDS IS HEREBY CHANGED TO, WEDNESDAY, OCTOBER 18, 2023 AT 2:00 PM

Bidder Acknowledgment:

Signature

Printed Name/Title

Respondent Company Name

Attachments: None

END OF ADDENDUM NO. #1

Purchasing Division | 500 San Sebastian View, St. Augustine, FL 32084 | 904.209.0150 | sjcfl.us

BID NO: 23-94; CR 210 Widening from Trinity Way to Beachwalk Boulevard

TABLE OF CONTENTS

- I. General Terms and Conditions
- II. Revised Official County Bid Form
- III. Attachments:
 - Attachment "A" – St Johns County Board of County Commissioners Affidavit
 - Attachment "B" – Certificate as to Corporate Principal
 - Attachment "C" – Contractor's Qualification Statement
 - Attachment "D" – License/Certification/FDOT Work Class Pre-Qualification List
 - Attachment "E" – List of Proposed Sub-Contractors/Suppliers
 - Attachment "F" – Conflict of Interest Disclosure Form
 - Attachment "G" – Drug Free Work Place Form
 - Attachment "H" – Proof of Insurance
 - Attachment "I" – Relevant Experience of Bidder
 - Attachment "J" – Claims, Liens, Litigation History
 - Attachment "K" – Public Entity Crimes Statement
 - Attachment "L" – Non-collusion Certification
 - Attachment "M" – E-Verify Affidavit
 - Attachment "N" – Certificate of Compliance with Florida Trench Safety Act
 - Attachment "O" – Local Preference
 - Attachment "P" – Revised Schedule of Values – Eighteen (18) Months Completion Time
 - Bid Bond
 - Sealed Bid Mailing Label

SEPARATE DOCUMENTS:

- EXHIBIT "A" – CR 210 WIDENING CONSTRUCTION PLANS – Dated September 2023**
- EXHIBIT "B" – ECS FLORIDA LLC. GEOTECHNICAL REPORT - Dated December 27, 2019**
- EXHIBIT "C" – ST. JOHNS RIVER WATER MANAGEMENT PERMIT 99121-21 – Dated September 16, 2016**

END OF TABLE OF CONTENTS

BID NO: 23-94; CR 210 Widening from Trinity Way to Beachwalk Boulevard

**OFFICIAL COUNTY BID FORM
ST. JOHNS COUNTY, FLORIDA**

TO: THE BOARD OF COUNTY COMMISSIONERS OF ST. JOHNS COUNTY, FLORIDA

DATE SUBMITTED: _____

BID PROPOSAL OF

Full Legal Company Name

Mailing Address

Telephone Number

Fax Number

Bidders: Having become familiar with requirements of the project, and having carefully examined the Bidding Documents and Specifications entitled for Bid No: 23-94; CR 210 Widening from Trinity Way to Beachwalk Boulevard in St. Johns County, Florida, the undersigned proposes to furnish all materials, labor and equipment, supervision and all other requirements necessary to comply with the Contract Documents to submit the following Bid Proposal summarized as follows:

Total Lump Sum Bid: 18 Months Completion Time: (As per Exhibit A – CR 210 Widening from Trinity Way to Beachwalk Boulevard Construction Plans – Dated September 2023). The Base Bid includes all work to construct the project from Trinity Way to Beachwalk Boulevard, as shown on the base bid plan sheets.

\$ _____

Lump Sum Bid Price (Numerical)

_____/100 Dollars

Lump Sum Bid Price (Amount written or typed in words)

Bidder shall insert the Lump Sum Bid Price above, in numerals and in words. In the event of a discrepancy between the two, the amount shall be determined by the amount written in words.

BID NO: 23-94; CR 210 Widening from Trinity Way to Beachwalk Boulevard

During the preparation of the Bid, the following addenda, if any, were received:

No.: _____ Date Received:

No.: _____ Date Received:

No.: _____ Date Received:

We, the undersigned, hereby declare that no person or persons, firm or corporation, other than the undersigned are interested, in this proposal, as principals, and that this proposal is made without collusion with any person, firm or corporation, and we have carefully and to our satisfaction examined the Bid Documents and Project Specifications.

We have made a full examination of the location of the proposed work and the sources of supply of materials, and we hereby agree to furnish all necessary labor, equipment and materials, fully understanding that any quantities shown therewith are approximate only, and that we will fully complete all requirements therein as prepared by the County, within the same time limit specified in the Bid Documents as indicated above.

If the Undersigned is notified of the acceptance of this Bid Proposal by the Board within ninety (90) calendar days for the time set for the opening of Bids, the Undersigned further agrees, to execute a contract for the above work within ten (10) days after notice that his Bid has been accepted for the above stated compensation in the form of a Contract presented by the County.

The Undersigned further agrees that security in the form of a Bid Bond, certified or cashier's check in the amount of not less than **five percent (5%) of Total Lump Sum Bid Price**, payable to the County, accompanies this Bid; that the amount is not to be construed as a penalty, but as liquidated damages which said County will sustain by failure of the Undersigned to execute and deliver the Contract and Bond within ten (10) days of the written notification of the Award of the Contract to him; thereupon, the security shall become the property of the County, but if this Bid is not accepted within ninety (90) days of the time set for the submission of Bids, or if the Undersigned delivers the executed Contract upon receipt, the Security shall be returned to the Bidder within seven (7) working days.

BID NO: 23-94; CR 210 Widening from Trinity Way to Beachwalk Boulevard

REVISED - ATTACHMENT "P"

REVISED SCHEDULE OF VALUES - EIGHTEEN (18) MONTHS COMPLETION TIME

Bidders shall complete and submit with their Bid Proposal this Schedule of Values to demonstrate the breakdown of costs included in the submitted Lump Sum Bid Price. Quantities provided herein are estimates only and Bidders are responsible for appropriately estimating quantities for inclusion in the submitted Lump Sum Bid Price.

Bid Item	Pay Item	Description	Quantity	Unit	Cost Per Unit	Total Cost
General						
1	101 1	MOBILIZATION	1	LS	\$	\$
2	102 1	MAINTENANCE OF TRAFFIC	1	LS	\$	\$
3	104 10 3	SEDIMENT BARRIER	6004	LF	\$	\$
4	104 12	STAKED TURBIDITY BARRIER	690	LF	\$	\$
5	104 18	INLET PROTECTION SYSTEM	51	EA	\$	\$
6	110 1 1	CLEARING AND GRUBBING	12.47	AC	\$	\$
7	110 4 10	REMOVAL OF EXISTING CONCRETE	2018	SY	\$	\$
General Sub-Total						\$
Roadway						
8	120 1	REGULAR EXCAVATION	3560	CY	\$	\$
9	120 6	EMBANKMENT	21194	CY	\$	\$
10	160 4	TYPE B STABILIZATION	40728	SY	\$	\$
11	285 711	OPTIONAL BASE GROUP 11, 12" LIMEROCK	36118	SY	\$	\$
12	327 70 6	MILLING EXISTING ASPHALT PAVEMENT, 1 1/2" AVG DEPTH	5,217	SY	\$	\$
13	334 1 12	SUPERPAVE ASPHALT PAVEMENT, TRAFFIC B (3")	5,960	TN	\$	\$
14	334 1 12	SUPERPAVE ASPHALT PAVEMENT, TRAFFIC B (1.5")	3,410	TN	\$	\$
15	520 1 10	CONCRETE CURB & GUTTER, TYPE F	9,005.00	LF	\$	\$
16	520 5 41	TRAFFIC SEPARATOR CONCRETE - TYPE IV, 4' WIDE	1,396.00	LF	\$	\$
17	522 1	CONCRETE SIDEWALK AND DRIVEWAYS, 4" THICK	3,252	SY	\$	\$
18	522 2	CONCRETE SIDEWALK AND DRIVEWAYS, 6" THICK	729	SY	\$	\$
19	527 2	DETECTABLE WARNINGS	337	SF	\$	\$
20	570 1 1	PERFORMANCE TURF	13,990	SY	\$	\$
21	570 1 2	PERFORMANCE TURF, SOD	6,012	SY	\$	\$
Roadway Sub-Total						\$
Drainage						
22	425 1 311	INLETS, CURB, TYPE P-1, <10'	9.00	EA	\$	\$
23	425 1 315	INLETS, CURB, TYPE P-1, PARTIAL	2.00	EA	\$	\$
24	425 1 321	INLETS, CURB, TYPE P-2, <10'	7.00	EA	\$	\$
25	425 1 411	INLETS, CURB, TYPE J-1, <10'	2.00	EA	\$	\$

26	425 1 412	INLETS, CURB, TYPE J-1, >10'	4.00	EA	\$	\$
27	425 1 421	INLETS, CURB, TYPE J-2, <10'	6.00	EA	\$	\$
28	425 1 471	INLETS, CURB, TYPE 7, <10'	5.00	EA	\$	\$
29	425 1 521	INLETS, DT BOT, TYPE C, <10'	2.00	EA	\$	\$
30	425 1 541	INLETS, DT BOT, TYPE D, <10'	5.00	EA	\$	\$
31	425 2 61	MANHOLES, P-8, <10'	1.00	EA	\$	\$
32	425 2 92	MANHOLES, J-8, >10'	5.00	EA	\$	\$
33	430 175 118	PIPE CULVERT, OPTIONAL MATERIAL, ROUND 18"	1,318.00	LF	\$	\$
34	430 175 124	PIPE CULVERT, OPTIONAL MATERIAL, ROUND 24"	274.00	LF	\$	\$
35	430 175 130	PIPE CULVERT, OPTIONAL MATERIAL, ROUND 30"	476.00	LF	\$	\$
36	430 175 136	PIPE CULVERT, OPTIONAL MATERIAL, ROUND 36"	746.00	LF	\$	\$
37	430 175 142	PIPE CULVERT, OPTIONAL MATERIAL, ROUND 42"	843.00	LF	\$	\$
38	430 175 148	PIPE CULVERT, OPTIONAL MATERIAL, ROUND 48"	855.00	LF	\$	\$
39	430 174 218	PIPE CULVERT, OPTIONAL MATERIAL, OTHER SHAPE, ELLIP/ARCH, 18"	442.00	LF	\$	\$
40	430 174 224	PIPE CULVERT, OPTIONAL MATERIAL, OTHER SHAPE, ELLIP/ARCH, 24"*	322.00	LF	\$	\$
41	430 530 100	STRIAGHT CONCRETE ENDWALL, 30", SINGLE, 0 DEG, ROUND	2.00	EA	\$	\$
42	430 984 625	MITERED END SECTION, OPTIONAL - ELLIP/ARCH, 18"	6.00	EA	\$	\$
43	430 984 629	MITERED END SECTION, OPTIONAL - ELLIP/ARCH, 24"	2.00	EA	\$	\$

Drainage Sub-total \$

Signing and Pavement Marking

44	700 1 11	SINGLE POST SIGN, F&I GROUND MOUNT, UP TO 12 SF	9.00	AS	\$	\$
45	700 1 12	SINGLE POST SIGN, F&I GROUND MOUNT, 12-20 SF	1.00	AS	\$	\$
46	700 1 50	SINGLE POST SIGN, RELOCATE	1.00	AS	\$	\$
47	700 1 60	SINGLE POST SIGN, REMOVE	14.00	AS	\$	\$
48	705 11 1	DELINEATOR, FLEXIBLE TUBULAR	5.00	EA	\$	\$
49	706 1 3	RAISED PAVEMENT MARKER, TYPE B	721.00	EA	\$	\$
50	711 11 102	THERMOPLASTIC, STANDARD, WHITE, SOLID 8"	0.08	GM	\$	\$
51	711 11 123	THERMOPLASTIC, STANDARD, WHITE, SOLID 12"	1,417.00	LF	\$	\$
52	711 11 124	THERMOPLASTIC, STANDARD, WHITE, SOLID 18"	513.00	LF	\$	\$
53	711 11 125	THERMOPLASTIC, STANDARD, WHITE, SOLID 24"	313.00	LF	\$	\$

54	711 11 141	THERMOPLASTIC, STANDARD, WHITE, 2-4 DOTTED GUIDELINE, 6"	0.16	GM	\$	\$
55	711 11 160	THERMOPLASTIC, PREFORMED, WHITE, MESSAGE	18.00	EA	\$	\$
56	711 11 170	THERMOPLASTIC, PREFORMED, WHITE, ARROW	64.00	EA	\$	\$
57	711 11 224	THERMOPLASTIC, STANDARD, YELLOW, SOLID 18"	170.00	LF	\$	\$
58	711 15 101	THERMOPLASTIC, STANDARD OG ASPHALT, WHITE, SOLID, 6"	2.63	GM	\$	\$
59	711 15 131	THERMOPLASTIC, STANDARD OG ASPHALT, WHITE, SKIP, 6" 10-30 SKIP	1.92	GM	\$	\$
60	711 15 201	THERMOPLASTIC, STANDARD OG ASPHALT, YELLOW, SOLID, 6"	1.45	GM	\$	\$
Signing and Pavement Marking Sub-Total						\$
Total Lump Sum Bid Price						\$



**Board of County Commissioners
St. Johns County, Florida**

INVITATION FOR BIDS NO: 23-94

CR 210 WIDENING FROM TRINITY WAY TO BEACHWALK BOULEVARD

St. Johns County Purchasing Division
500 San Sebastian View
St. Augustine FL 32084
(904) 209-0150
www.sjcfcl.us/Purchasing/index.aspx

FINAL: 09/05/2023

BID NO: 23-94; CR 210 Widening from Trinity Way to Beachwalk Boulevard

TABLE OF CONTENTS

- I. General Terms and Conditions
- II. Official County Bid Form
- III. Attachments:

Attachment "A" – St Johns County Board of County Commissioners Affidavit
Attachment "B" – Certificate as to Corporate Principal
Attachment "C" – Contractor's Qualification Statement
Attachment "D" – License/Certification/FDOT Work Class Pre-Qualification List
Attachment "E" – List of Proposed Sub-Contractors/Suppliers
Attachment "F" – Conflict of Interest Disclosure Form
Attachment "G" – Drug Free Work Place Form
Attachment "H" – Proof of Insurance
Attachment "I" – Relevant Experience of Bidder
Attachment "J" – Claims, Liens, Litigation History
Attachment "K" – Public Entity Crimes Statement
Attachment "L" – Non-collusion Certification
Attachment "M" – E-Verify Affidavit
Attachment "N" – Certificate of Compliance with Florida Trench Safety Act
Attachment "O" – Local Preference
Attachment "P" – Schedule of Values – Eighteen (18) Months Completion Time
Attachment "Q" – Schedule of Values – Fifteen (15) Months Completion Time
Bid Bond
Sealed Bid Mailing Label

SEPARATE DOCUMENTS:

- EXHIBIT "A" – CR 210 WIDENING CONSTRUCTION PLANS – Dated February 23, 2023**
- EXHIBIT "B" – ECS FLORIDA LLC. GEOTECHNICAL REPORT - Dated December 27, 2019**
- EXHIBIT "C" – ST. JOHNS RIVER WATER MANAGEMENT PERMIT 99121-21 – Dated September 16, 2016**

END OF TABLE OF CONTENTS

PART I – GENERAL TERMS AND CONDITIONS

1) DEFINITIONS

Terms used within this Invitation for Bids (“IFB”) shall have the meaning as set forth in the St. Johns County Purchasing Policy (“Policy”), or as otherwise defined herein. Any definition provided herein, shall govern over the definitions provided in the Policy.

2) COMPLIANCE WITH ST. JOHNS COUNTY PURCHASING POLICY

All provisions of the Policy and associated procedures are incorporated into the Bid Documents by reference, and are fully binding. Bidders are required to submit their Bids, and to conduct their activities in accordance with the Policy and associated procedures.

3) BIDDER’S REPRESENTATION

By submitting a Bid, each Bidder represents and warrants that Bidder has read and understands all information and requirements provided herein, and that Bidder is familiar with and understands all conditions related to the work specified herein, and the submitted Bid is based upon all necessary considerations to perform the work in accordance with all specifications and requirements provided herein, or as otherwise provided in an Addendum. Bidder also represents that any and all costs associated with performing the specified work are included in the submitted Bid.

4) BID DOCUMENTS

The Bid Documents are those documents which shall govern the solicitation, submittal, consideration and award of submitted Bid(s), which generally includes, but is not limited to: IFB Documents, Specifications, Plans, Drawings, and all issued Addenda.

Bid Documents may be obtained from www.demandstar.com or SJC Purchasing Division. The Bid Documents shall be used by Bidders to prepare their Bid for submittal. St. Johns County (“County”) shall not assume any responsibility for errors or misrepresentations resulting from the use of complete or incomplete sets of Bid Documents. The County, in making the Bid Documents available, do so only for the purpose of obtaining Bids for the specified purpose and do not confer a license or grant for any other use.

5) INTERPRETATION OR CORRECTION OF BID DOCUMENTS

Bidders shall promptly notify the Designated Point of Contact of any ambiguity, inconsistency, or error which they may discover upon examination of the Bid Documents or of the site and local conditions. Bidders requiring clarification or interpretation of the Bid Documents shall make a written request to the Designated Point of Contact by or before the deadline for questions as provided herein.

An interpretation, correction or change of the Bid Documents will be made by Addendum. Interpretations, corrections, or changes of the Bid Documents made in any other manner will not be binding, and Bidders must not rely upon such interpretations, corrections, or changes. No change will be made to the Bid Documents by the County less than seven (7) days prior to the submittal deadline for Bids. The County, however, reserves the right to issue addendums at any time prior to the submittal deadline for Bids in order to serve the best interest of the County.

6) SUBSTITUTIONS

The materials, products and equipment described in the Bid Documents establish a standard of required function, dimension, appearance and quality to be met by any proposed substitution. No substitution will be considered unless written request for approval has been received by the Designated Point of Contact at least fourteen (14) calendar days prior to the submittal deadline for Bids. Each such request shall include the name of the material or equipment for which it is to be substituted and a complete description of the proposed substitute, including drawings, cuts, performance and testing data, and any other information necessary for an evaluation. A statement setting forth any changes in other materials, equipment or work that incorporation of the substitute would require

must also be included. The burden of proof of the merit of the proposed substitute is upon the proposer of the substitute. The Project Manager's approval or disapproval of a proposed substitution shall be final.

If County Staff approves any proposed substitution, such approval will be set forth in an Addendum. Bidders must not rely upon approval made in any other manner.

7) DESIGNATED POINT OF CONTACT

The County's Designated Point of Contact for this Bid is Richard E. Poulin Jr., Procurement Coordinator, St. Johns County Purchasing Division. Any and all questions and/or inquiries shall be directed to Mr. Poulin, *in writing*, via email at rpoulin@sicfl.us. In the event the Designated Point of Contact is absent or otherwise unavailable for more than three (3) business days, firms may contact Bryan Matus, Senior Procurement Coordinator at bmatus@sicfl.us.

8) LOBBYING PROHIBITION

In accordance with Section 9 of the Policy, Bidders **SHALL NOT** contact any staff member of the County, including members of the Board of County Commissioners, except the above referenced Designated Point of Contact with regard to this Invitation for Bids. Any such communication is a violation of the Policy and shall result in disqualification and removal from consideration for award under this IFB.

9) PRE-BID MEETING

There will be a **Non-Mandatory Pre-Bid Meeting on Wednesday, September 13, 2023 at 9:00 AM EDST** in the Public Works Main Conference Room at the St. Johns County Public Works Department, 2750 Industry Center Road, St. Augustine FL 32084. Attendance is strongly recommended, but is not required at the Pre-Bid Meeting in order to be eligible to submit a bid for this project. Bidders and sub-contractors are highly encouraged to visit the site prior to the Pre-Bid Meeting to familiarize themselves with the site and any conditions that may pose a conflict during the course of construction.

10) QUESTIONS

Any and all questions related to this project shall be directed, *in writing*, to the Designated Point of Contact. Questions are due no later than Four o'clock (**4:00PM**) **EDST on Wednesday, September 20, 2023**, so that any necessary addenda may be issued in a timely manner. Any questions received after the deadline will not be answered unless previously approved by the SJC Purchasing Manager or other designated County Representative.

11) ADDENDA

Any change, clarification, revision, deletion, additional documents or information provided by the County after broadcast of this IFB will be provided via Addendum, and posted to Demandstar (www.demandstar.com) with the Bid Documents. All planholders for this IFB will be notified of the posted addendum by Demandstar. Planholders may access and download issued Addenda for inclusion in their submitted Bid. Bidders may also request issued addenda from the Designated Point of Contact, in writing. It is the responsibility of the Bidder to acquire any addenda issued by the County. The County is not responsible for a Bidder's failure to obtain any issued Addendum.

Bidders are responsible for incorporating any and all changes, clarifications, revisions, deletions, additional documents and information provided by Addendum into the submitted Bid. Failure by the Bidder to appropriately consider and incorporate the addenda into their submitted Bid may cause the submitted Bid to be considered non-responsive and removed from further consideration. It shall be the sole discretion of the Purchasing Manager or Assistant Director of Purchasing and Contracts to determine whether or not an Addendum is material to the submitted Bid, resulting in disqualification and removal from consideration for award.

Each Bidder shall acknowledge all issued Addenda in the submitted Bid in the space provided on the Official County Bid Form, and provide a copy of each Addendum, signed by the Bidder's authorized representative.

12) BID SUBMITTAL REQUIREMENTS

The submittal deadline for Bids shall be no later than two o'clock (**2:00PM EDST**) on **Wednesday, October 11, 2023 ("Submittal Deadline")**. Bids must be submitted to:

SJC Purchasing Division
500 San Sebastian View
St. Augustine, FL 32084

Each Bidder must submit one (1) original hard copy, on the required forms provided herein, in a sealed envelope or container plainly marked with the Bidder's full legal company name, mailing address, and recite: "**BID NO: 23-94; CR 210 Widening from Trinity Way to Beachwalk Boulevard**". A mailing label has been provided herein for Bidders to use to identify their Bid.

All required forms and attachments, including the Official County Bid Form, must be completed, and all required information provided. Information must be typewritten or manually written in blue or black ink. Each Bid must include the Bidder's full legal company name, mailing address, telephone number, and must identify whether the Bidder is a sole proprietor, partnership, corporation or other legal entity. **The submitted Bid should NOT include a full copy of the Bid General Terms and Conditions.**

Bidder shall assume full responsibility for timely delivery of their submitted Bid at the location designated above for receipt of Bids. Bids shall be delivered to the designated location prior to the submittal deadline provided above, or as revised by addendum. Bids received after the established submittal deadline will not be considered and will be returned to the sender unopened.

All mail delivered to the County is processed through SJC Central Receiving. Bidders must factor the additional time for processing when mailing their submitted Bids to the County. Any Bids that are not delivered to the SJC Purchasing Division, by the deadline above, shall not be considered, even if the Bid is delivered to SJC Central Receiving prior to the deadline above. SJC Purchasing is not responsible for Bids that are delayed in delivery due to mail processing activities of the County's Central Receiving Office.

Additionally, the County is not responsible for Bids that are incorrectly labeled, addressed, mailed, or otherwise delivered to an incorrect location other than the SJC Purchasing Division. Any such Bid that is not received in the SJC Purchasing Division shall be returned to the Bidder, unopened.

Bidders must only submit one (1) Bid in response to this IFB. Oral, telephonic, telegraphic, or electronic Bids are invalid and will not receive consideration.

Where so indicated by the makeup of the Bid Form, sums shall be expressed in both words and numerals, and in the case of a discrepancy between the two, the amount expressed in words shall govern. Additionally, where there are unit prices and extended prices, the unit prices shall govern over extended pricing.

Any interlineations, alterations, or erasures by the Bidder on the Bid Form must be initialed by the signer of the Bid. Failure to do so may cause the Bid to be considered non-responsive.

Bidder shall make no stipulation on the Bid Form, nor qualify the submitted Bid in any manner. To do so will classify the Bid as being non-responsive.

Any submitted Bid must be signed by an approved representative of the Bidder, legally authorized to bind the Bidder to a contract. In the event the Bid is signed by a representative who is not a principal of the Bidder, a Delegation of Authority Letter must be submitted with the Bid, stating the delegation of authority by principal(s), owner(s), or officer(s) of the Bidder for the signing representative. The delegation of authority must be signed by the principal/owner/officer of the Bidder, and must state the limits and duration of the delegation to the signing representative.

A Bid submitted by an agent must have a current Power of Attorney attached, certifying the agent's authority to bind the Bidder.

All Bids submitted in response to this IFB shall become the property of the County and will not be returned to the Bidders. In the event of an award, all documentation produced as part of the award shall become exclusive property of the County.

13) BID SECURITY

Each submitted Bid must be accompanied by a Bid Security, submitted on the Bid Bond Form provided herein, or in the form of a certified or cashier's check, in the amount of **five percent (5%) of the Lump Sum Bid Price** amount submitted on the Official County Bid Form, pledging that the Bidder will enter into a contract with the County on the terms stated in the Bid and will, if required, furnish bonds as described hereunder covering the faithful performance of the Contract and the payment of all obligations arising thereunder. Should the Bidder refuse to enter into such Contract or fail to furnish such bonds to the County, if required, the amount of the Bid Security shall be forfeited, not as penalty, but as liquidated damages.

A Bid Security in the form of a certified or cashier's check must be made payable to the Board of County Commissioners of St. Johns County. Bidders submitting a certified or cashier's check as the bid security are not required to submit **Attachment "B" – Certificate as to Corporate Principal**, or the Bid Bond forms provided herein.

A Bid Security in the form of a Bid Bond shall be written on the form provided herein, with an acceptable surety, and the Attorney-in-Fact who executes the bond on behalf of the surety shall affix to the bond a certified and current copy of his Power of Attorney. Acceptable surety companies are defined herein under "Surety Bond". The Surety Company shall be licensed to do business in the State of Florida and shall be listed by the U.S. Treasury Department. Any Bidder submitting a Bid Security in the form of a Bid Bond must also submit **Attachment "B" – Certificate as to Corporate Principal**.

The County shall have the right to retain the Bid Security until either (a) a Contract is executed and bonds, if required, have been furnished, or (b) the County has rejected all Bids, or (c) the period of time for which Bids are irrevocable has elapsed, so that Bids may be withdrawn.

14) BID BOND INSTRUCTIONS

A Bid Bond submitted, on the form provided herein, must be completed as follows:

- Type or Print Bidder's and Surety's names, mailing addresses, in the same language as in the Bid Documents;
- Have authorized representatives of the Bidder and Surety/Surety's Agent sign in the designated spaces;
- Attach a copy of Surety agent's Power of Attorney with an original signature of the Secretary or Assistant Secretary of Surety certifying the copy, unless the Power of Attorney has been recorded in St. Johns County. If it has been recorded, provide book and page number.
- Submit one (1) original and one (1) duplicate, as prescribed herein for Submittal of Bids.

15) SURETY REQUIREMENTS

Any Surety issuing a Bond to the County, must meet the following requirements:

- Surety must be licensed to do business in the State of Florida;
- Surety must have a record of successful continuous operations for at least three (3) years;
- Surety shall not have exposed itself to any loss on any one risk in an amount exceeding twenty percent (20%) of its surplus to policyholders;
- Surety must have fulfilled all of its obligations on all other bonds given to the County;
- Surety must have good underwriting, economic management, adequate reserves for undisclosed liabilities, and net resources for unusual stock and sound investment.

16) BID POSTPONEMENT/CANCELLATION

The County may, at its sole and absolute discretion, postpone or cancel this IFB, and/or resolicit Bids in order to serve the best interest of the County.

17) MODIFICATION OR WITHDRAWAL OF BID

A submitted Bid may not be modified, withdrawn or canceled by the Bidder after the submittal deadline specified herein.

Prior to the submittal deadline for Bids, a Bid submitted early may be modified or withdrawn only by written notice to the Designated Point of Contact. Upon notice from a Bidder to modify or withdraw a submitted Bid, provided such notice is received prior to the submittal deadline for Bids, the County shall return the Bid to the Bidder unopened. Any modified Bids must be submitted prior to the submittal deadline specified herein, in order to be considered.

18) COSTS INCURRED BY BIDDERS

Bidders are responsible for any and all costs associated with developing and submitting a Bid in response to this IFB. Additionally, Bidders are solely responsible for any and all costs associated with providing any subsequent information requested by the County, attending any meetings with the County, and any other activities related to this solicitation and subsequent award proceedings. It is expressly understood, no Bidder may seek or claim any award and/or reimbursement from the County for any expenses, costs, and/or fees (including attorney's fees) borne by any Bidder, during the IFB process. Such expenses, costs, and/or fees (including attorney's fees) are the sole responsibility of the Bidder.

19) CONSIDERATION OF BIDS

Opening of Bids: Unless stated otherwise in an Addendum, Bids received by or before the submittal deadline will be opened publicly, immediately after the submittal deadline provided herein. The Bid Tabulation shall be posted to DemandStar, upon verification of Bids and all information.

Rejection of Bids: The County reserves the right to reject any or all Bids that are not materially responsive to the requirements provided herein, or if it is determined to be in the best interest of the County. The County may also waive any minor formality or irregularity of any submitted Bid, provided the minor formality or irregularity does not materially impact the submitted Bid.

Bid Award: It is the intent of the County to award to the lowest, responsive, responsible Bidder(s), based upon the Lump Sum Bid Price.

If an award is made, it will be made within ninety (90) days from the date of the Bid opening, unless stated otherwise in an Addendum. Submitted Bids must remain valid for a minimum of ninety (90) days from the date of the Bid opening, and shall be irrevocable during this time unless otherwise agreed to by the County.

If only one (1) Bid is received, the County reserves the right to negotiate with the responding Bidder, if the submitted Bid is responsive to the requirements provided herein. The Bid may also be rejected and the Bid re-advertised, in order to best serve the needs of the County.

The County shall have the right to award Total Lump Sum Bid or Alternate #1 Total Lump Sum Bid in order to serve the best interest of the County to do so.

20) LOCAL PREFERENCE

The County shall review all submitted bids to determine whether or not there is a Local Business within ten percent (10%) of the responsive, responsible low bid. If so, County shall verify all qualification requirements to validate the Vendor as a Local Business, in accordance with Section 16.3, SJC Purchasing Policy. If the lowest bid from a Local Business is responsive and the Bidder is responsible to perform the work, and the submitted bid is within ten percent (10%) of the low bid, the Local Bidder shall have forty-eight (48) hours to agree, in writing, to match the low bid amount. If the Local Bidder agrees to match the low bid amount within the timeframe provided, the Local Bidder shall be awarded the bid, provided they meet any and all other requirements of the County. If the Local Bidder refuses, or fails to agree to match the low bid, the County shall consider the non-local low bid for

award.

In order to receive local preference consideration, vendor must qualify as a local business, and self-perform, or have perform by subcontractors that qualify as a local business, a minimum of fifty percent (50%) of all work. Fifty percent (50%) of all work must equal fifty percent (50%) of the contract price.

21) PROTESTS

Any actual Bidder who is aggrieved in connection with the Notice of Intent to award a Contract (Protestor), where such grievance is asserted to be the result of a violation of the requirements of the County's Purchasing Policy and associated procedures, or any applicable provision of law by the officers, agents, or employees of the County, may file a Protest with the Assistant Director of Purchasing & Contracts. The Protest must be submitted in writing, accompanied by a security in the form of a Protest Bond, by 4:00PM on the fifth business day following the date of the posting of the Notice of Intent to Award.

22) MINIMUM QUALIFICATIONS

Bidders must possess current and valid licenses to conduct business in the State of Florida and appropriately registered to do business in St. Johns County as a Certified General Contractor (CGC) or Certified Underground Utility and Excavation Contractor (CUC), or utilize sub-contractors currently licensed as CGC or CUC in the State of Florida and St. Johns County. Proof of qualifications shall be provided by completing and submitting **Attachment "C" – Contractor's Qualifications Statement and Attachment "D" – License/Certification/FDOT Work Class Pre-Qualification List** along with a copy of each license and certificate listed. All licenses, certifications and pre-qualifications must be valid and current on the date bids are submitted.

Additionally, the prime or proposed sub-contractor performing any work in the following work classes shall be currently Florida Department of Transportation (FDOT) pre-qualified: (7) Drainage, (10) Flexible Paving, (11) Grading, (28) Pavement Marking, (38) Roadway Signing, and (40) Sidewalk. A letter from FDOT confirming pre-qualification, current at the time of bid submittal, in the required work classes must be submitted under **Attachment "D" – License/Certification/FDOT Work Class Pre-Qualification List**.

The Bidder must submit a list of any and all relevant experience within the last five (5) years with the proposed scope of work. The list must include the Client's information, total contract value, and completion timeframes. The County reserves the right to check any and all references.

Failure by a Bidder to demonstrate meeting or exceeding the minimum qualification requirements stated above shall be grounds for disqualification and removal from further consideration for award. The County reserves the right to request additional information regarding the qualification and experience of the Bidder in order to determine the responsibility of the Bidder to perform the specified work.

Bidders to whom award of a contract is under consideration shall submit to the County, upon request, a properly executed Contractor's Qualification Statement of A1A Document A305, unless such a statement has been previously required and submitted as a prerequisite to the issuance of Bidding Documents.

23) SUB-CONTRACTORS

Each Bidder shall submit to the County, a list of Subcontractors and major materials suppliers to be used if awarded the contract. A copy of the form, **Attachment "E"**, is provided in the Bidding Documents. If no Subcontractors or major material suppliers are required, so state there on.

Upon request by the County, the successful Bidder shall within seven (7) days thereafter, submit all data required to establish to the satisfaction of the County, the reliability and responsibility of the proposed Subcontractors to furnish and perform the work described in the Sections of the Specifications pertaining to such proposed Subcontractor's respective trades.

Prior to the award of the Contract, the County will notify the Bidder in writing if the County, after due investigation,

has reasonable and substantial objection to any person or organization proposed as a Subcontractor. The Bidder then may, at his option, withdraw his Bid without forfeiture of Bid Security or submit an acceptable substitute at no increase in Bid price. If the Bidder fails to submit an acceptable substitute within seven (7) days of the original notification, the County may then, at its option, disqualify the Bidder, at no cost to the County.

The County reserves the right to disqualify any Contractor, Subcontractor, Vendor, or material supplier due to previously documented project problems, either with performance or quality.

Subcontractors and other persons and organizations proposed by the Bidder and accepted by the County, must be used on the work for which they were proposed and accepted and shall not be changed except with the written approval of the County.

24) FLORIDA TRENCH SAFETY ACT

Bidders shall complete Certificate of Compliance with Florida Trench Safety Act, in accordance with the requirements of Chapter 553, Florida Statutes. If trenching is not required for this project, state so thereon. Contractor shall be responsible for compliance with all trenching shoring safety requirements. A copy of the form, **Attachment "N"**, is provided in the Bidding Documents.

25) PUBLIC CONSTRUCTION BOND

The awarded Contractor shall be required to obtain and submit a recorded Public Construction Bond covering the faithful performance of the Contract and the payment of all obligations arising thereunder in full amount of the awarded Contract, with such acceptable sureties, secured through the Bidder's usual sources as may be agreeable to the parties. The Contractor shall furnish the required bond, after full execution of the awarded Contract. The Bond shall be released upon satisfactory completion of the project.

The Public Construction Bond form will be provided to the awarded Contractor with the fully executed contract. The Contractor shall provide the recorded Public Construction Bond to the County within three (3) business days of receipt of the bond form and executed contract. **The Public Construction Bond must be recorded after the contract is signed by all parties.**

Contractor shall record the Public Construction Bond with the St. Johns County Clerk of Courts, and obtain a certified copy of the recorded bond and provide to the SJC Purchasing Division. No work shall commence until the required bond has been delivered to the Owner. Upon receipt of the certified copy of the recorded bond, the Owner may issue a Notice to Proceed.

Unless otherwise specified in the Bid Documents, the bonds shall be written on the form provided herein. The Bidder shall require the Attorney-in-Fact who executes the required bonds on behalf of the Surety to affix thereto a certified and current copy of his Power of Attorney authorizing his firm to act as agent for the Surety in issuing the bonds.

26) FORM OF AGREEMENT BETWEEN COUNTY AND CONTRACTOR

Unless otherwise provided in the Bidding Documents, the Agreement for Work will be written on the St. Johns County Master Construction Agreement.

27) EXECUTION OF CONTRACT DOCUMENTS

The awarded Contractor shall return signed copies of the Contract Agreement to the SJC Purchasing Division within ten (10) consecutive calendar days of receipt of Notice of Award. St. Johns County shall return a fully executed original copy of the Contract Agreement to the Contractor no later than seven (7) consecutive calendar days after the return of the signed copies from the Contractor.

28) CONTRACT TIME – LIQUIDATED DAMAGES

The Contractor shall have ten (10) days to return Contract originals from the time the Contractor receives a "Notice of

Award". St. Johns County will return a "fully executed" Contract to the Contractor no later than seven (7) days after the return of the executed Contract originals (but no later than seventeen (17) days from the Notice of Award).

The Contractor will furnish a recorded original certified copy of the Public Construction Bond three (3) business days after receipt of the fully executed Contract (the Public Construction Bond must be recorded after the Contract is fully executed by all parties including the County Clerk). Upon receipt of the recorded Public Construction Bond, the County will issue a Notice to Proceed. If the Contractor fails to meet any of the dates and timeframes set forth in this section, or fails to execute the Contract, or to provide a Public Construction Bond, the County may elect at its option to consider the Contractor non-responsive and Contract with the next lowest, responsible Bidder.

The work to be performed under this Agreement shall be commenced within **ten (10)** days of the date of the Notice to Proceed, in writing. Construction of the project shall be substantially complete within **Five Hundred Eighteen (518)** consecutive calendar days from the date stipulated on the Notice to Proceed. Final completion shall be attained **Thirty (30)** consecutive calendar days from the date of substantial completion.

Conditions under which Liquidated Damages are Imposed:

Should the Contractor or, in case of his default, the Surety fail to achieve Substantial Completion or Final Completion of the Work by its applicable date, or within such extra time as may have been granted by the County, the Contractor or, in case of his default, the Surety shall pay to the County, not as a penalty but rather a genuine pre-estimate of monetary damages sustained by the County for loss of revenue and/or increased project administration expenses related to this Contract because Contractor failed to perform and complete Work within the time fixed for completion or additional time granted pursuant to the provisions hereof. The assessment of Liquidated Damages are without prejudice to the County's rights of termination and Contractor's obligation to complete the Work. Should Contractor fall behind the approved Work schedule, the County reserves the right to deduct Liquidated Damages based on an estimated period of late completion, the amount so due as determined by the following schedule based on the Florida Department of Transportation (FDOT) 23-24 Standard Specifications Book for Road & Bridge Construction:

<u>Original Contract Amount</u>	<u>Daily Charge Per Calendar Day</u>
\$299,999 and under.....	\$980
\$300,000 but less than \$2,000,000.....	\$1,699
\$2,000,000 but less than \$5,000,000.....	\$2,650
\$5,000,000 but less than \$10,000,000.....	\$3,819
\$10,000,000 but less than \$20,000,000.....	\$4,687
\$20,000,000 but less than \$40,000,000.....	\$7,625
\$40,000,000 and over.....	\$10,467 (plus 0.00005 of any amount over \$40 million (Round to nearest whole dollar)

29) INDEMNIFICATION

Contractor shall indemnify and hold harmless the County and its officers and employees ("Indemnified Party"), from liabilities, damages, losses and costs, including, but not limited to, reasonable attorney's fees, to the extent caused by the negligence, recklessness, or intentional wrongful misconduct of Contractor and persons employed or utilized by Contractor in the performance of this Contract.

To the extent permitted by, and in accordance with Section 725.06 of the Florida Statutes, Contractor further agrees that "damages, losses and costs", includes fines, citations, court judgments, insurance claims, restoration costs or other liability, to the extent caused by the negligence, recklessness, or intentional wrongful misconduct of Contractor and persons employed or utilized by Contractor in performance of the Work.

To the extent permitted by, and in accordance with Section 725.06 of the Florida Statutes, for purposes of indemnity, the "persons employed or utilized by Contractor" shall be construed to include, but not be limited to, Contractor, its staff, employees, subcontractors, all deliverers, suppliers, furnishers of materials or services or anyone acting for, on behalf of, or at the request of Contractor.

In Claims against any person or entity indemnified hereunder by an employee of Contractor, any Subcontractor, or subcontractor, anyone directly or indirectly employed by them or anyone for whose acts they may be liable, the indemnification obligation under this Section 11.2 shall not be limited by a limitation on the amount or type of damages, compensation or benefits payable by or for Contractor or any Subcontractor or subcontractor under any workers' compensation acts, disability benefits acts or other employee benefit acts.

Contractor's indemnity and hold harmless obligations hereunder shall extend to all Claims against the County by any third party or third-party beneficiary and all liabilities, damages, losses and costs related thereto.

This indemnification will not be valid in the instance where the loss is caused by the gross negligence, or willful, wanton or intentional misconduct of any Indemnified Party.

If any provision(s), or portion(s) of a provision(s) of this Section, or the application thereof to any person or circumstance shall, to any extent, be held to be invalid, illegal or unenforceable for any reason whatsoever, the validity, legality and enforceability of the remaining provision(s), or part of the provision(s), shall not in any way be affected or impaired thereby; and shall be interpreted to the fullest extent possible to be enforceable and to give effect to the intent manifested by the provision(s), or portion(s) thereof, held invalid, illegal or unenforceable.

Contractor shall further indemnify and hold harmless the County its officers and employees from and against all Claims arising out of any infringement of patent rights or copyrights incident to the use in the performance of the Work or resulting from the incorporation in the Work of any invention, design, process, product, or device not specified in the Contract Documents and shall defend such Claims in connection with any alleged infringement of such rights.

The indemnification provisions of this Section shall survive expiration or earlier termination of the Contract.

30) FORCE MAJEURE; DELAYS

Force Majeure: Contractor shall not be liable for failure to carry out the terms of this Agreement to the extent such failure is due to a Force Majeure event, except for failures that could have been reasonably foreseen and guarded against so as to avoid or reduce the adverse impact thereof. A Force Majeure event is hereby defined as the failure to carry out any of the terms of this agreement due to any one of the following circumstances beyond the control of the Contractor: (a) the operation and effect of the rules, regulations, or order promulgated by any commission, county, municipality, or governmental agency of the State of Florida or United States, (b) a restraining order, injunction, or similar decree on any court of competent jurisdiction, (c) war, (d) flood, (e) earthquake, (f) fire, (g) severe wind storm, (h) acts of public disturbance, (i) quarantine restrictions, (j) epidemics, (k) strikes, (l) freight embargoes, or (m) sabotage. The times specified herein for performances include delays that can ordinarily be anticipated due to adverse weather conditions. The County is not obligated to grant an extension of time due to the adverse weather condition unless such conditions rise to the level of Force Majeure.

Delay: Contractor shall not be compensated for delays caused by Contractor's inefficiency, rework made necessary by Contractor's work error, failure to perform the Work as scheduled, or any other corrective or productivity measures made necessary by errors, omissions, or failures to properly perform the Work. Neither shall the Contractor be compensated for delays caused by events by force majeure as described in sub-para (a) above. Within ten (10) days after the onset of a delay, Contractor shall notify the County in writing of the delay which shall provide: (1) a detailed description the delay and its probable duration, (2) the specified portion of the Work affected, and (3) an opinion as to the cause of the delay and liability (if any) for the delay. Notice provided more than ten (10) days after the inception of the delay shall only be effective as to additional time incurred during the ten (10) day period preceding receipt of such notice. In the case of continuing cause delay for the same cause, only one notice of delay is necessary. **Failure to provide this notice waives any claim for extension of time resulting from such delay.** If the delay is due to the failure of another County contractor to complete its work in a timely manner, changes ordered in the Work, a Force Majeure event, or any other cause which the County, in its sole judgment and discretion, determines to justify the delay, then the Completion Date may be extended as

necessary to compensate for the delay. All time extensions shall be in the form of a written amendment signed by both parties.

31) CONTRACTOR SAFETY AND HEALTH REQUIREMENTS

The Contractor shall be responsible for supervising all safety precautions, including initiating and maintaining such programs in connection with the performance of the Contract and for adequate maintenance of traffic.

The Contractor shall designate a member of the on-site construction team whose duty shall be the prevention of accidents. Unless notified otherwise in writing by the Contractor to the County and the Engineer, this person shall be the Contractor's Superintendent.

A. OSHA Requirements:

The Contractor warrants that the product, products, or services supplied to St. Johns County shall conform in all respects to the standards set forth in the Occupational Safety and Health Act (OSHA) of 1970 as amended and the failure to comply will be considered a breach of contract. St. Johns County shall be held harmless against any unsafe conditions and contractor employee incidents.

B. Compliance with Occupational Safety and Health Act:

Contractor certifies that all material, equipment, services, etc., furnished in this bid meets all OSHA requirements for the applicable Sectors. Bidder further certifies that, if he is the successful bidder, and the material, equipment, service, etc., delivered or provided is subsequently found to be deficient in any OSHA requirement in effect on date of delivery or service fulfillment date, all costs necessary to bring the material, equipment, service, etc., into compliance with the aforementioned requirements shall be borne by the bidder. All Personal Protective Equipment used by the contractor and their employees shall be ANSI certified and meet OSHA standards.

C. Training and Education:

Contractors will ensure that Contractor employees are trained appropriately for their work tasking. The minimum requirements are found in Federal and State Regulations. Examples of this training are (but not limited to):

- Lockout Tagout
- Fall Protection
- Electrical Safety and the National Electrical Code (NEC)
- Confined Space Entry
- Welding/Cutting/Brazing
- Specific Chemical Hazards
- Excavations and Trenching
- Heavy Equipment Operation

Special emphasis should be given towards training and compliance with the Construction industry's "Focus Four" established by OSHA as an outreach program to the construction industry and its workers. Training, education, and awareness should be provided in the areas of: 1) Fall Hazards, 2) Caught-In and Between Hazards, 3) Struck-By Hazards, and 4) Electrocution Hazards.

D. Toxic Substances/Federal Hazard Communication "Right To Know and Understand" Regulations:

The Federal "Right to Know and Understand" Regulation (also known as the Hazard Communication / Globally Harmonized System of Classification and Labeling of Chemicals (GHS) implemented by OSHA requires employers to inform their employees of any toxic substances to which they may be exposed in the workplace, and to provide training in safe chemical storage, labeling, handling practices and emergency procedures.

Accordingly, the Contractor(s) performing under this contract shall be required to provide two (2) complete sets of Safety Data Sheets (SDS) to each of the departments utilizing the awarded products. This information should be provided at the time when the initial delivery is made, on a department-by-department basis. If

performing work on site, it is preferred that each contractor bring their hazardous communication program and SDS in a binder labeled with the contractor's name and identified as a Hazardous Communication/GHS Program. Upon leaving the jobsite and the removal of all hazardous materials, contractors shall take their information with them. The transport, use, and disposal of toxic substances must be conducted in accordance with DEP/EPA regulations.

Upon request, contractors working at St. Johns County facilities or jobsites will be given access to the written Hazardous Communication Program and informed where to locate SDS.

E. Temporary Traffic Control (TTC)/Maintenance of Traffic (MOT)

The Contractor must comply with the Florida Department of Transportation's (DOT) Temporary Traffic Control (TTC) and the Manual on Uniform Traffic Control Devices (MUTCD) in the planning, development, design, implementation, operation, enforcement and inspection of work zone related transportation management and temporary traffic control on streets and highways within the State Highway System right-of-way. Training in the Advanced, Intermediate, and Flagger categories must be completed by the Contractor for their employees when performing right-of-way work while under contract with St. Johns County. Contractor employees must wear a Class II (daytime), Class III (night/limited visibility) high-visibility safety vest or equivalent high-visibility apparel while performing any work that places them in the right-of-way

32) TERMINATION

The County may, by written notice to Contractor, terminate the awarded Contract in whole or in part at any time for the County's convenience or for the default of the Contractor.

If, at any time, the awarded Contract is terminated by the County, whether for cause or for convenience, the County may, at its sole discretion, negotiate with the second lowest, responsible, responsive bidder for completion of the required Work if it serves the best interest of the County to do so.

33) TAXES

Project is subject to Federal Excise and Florida Sales Taxes, which must be included in Bidder's proposal.

34) INSURANCE

The Contractor shall not commence work under this Contract until he/she has obtained all insurance required under this section and such insurance has been approved by the County. All insurance policies shall be satisfactory to the County and shall be issued by companies authorized and duly licensed to transact business in the State of Florida. The Contractor shall furnish proof of Insurance to the County prior to the execution of this Contract. Certificates of insurance shall clearly indicate Contractor has obtained insurance of the type, amount, and classification as required by this Contract. Required insurance coverage shall be maintained in force, including coverage for Additional Insureds, until Final Completion of all Work including Warranty Work.

No less than ten (10) days written notice shall be provided to the County prior to cancellation, non-renewal or any material change of required insurance policies. Yearly renewal certificates shall be provided to the County within thirty (30) days of expiration of the current policy.

Certificates shall specifically include the County as Additional Insured for all lines of coverage except Workers' Compensation and Professional Liability. A copy of the endorsement must accompany the certificate. Compliance with the foregoing requirements shall not relieve the Contractor of its liability and obligations under this Contract.

Certificate Holder Address: St. Johns County, a political subdivision of the State of Florida
500 San Sebastian View
St. Augustine, FL 32084
Attn: Purchasing Division

The Contractor shall procure and maintain during the life of this Contract, Comprehensive General Liability

Insurance with minimum limits of \$1,000,000 per occurrence, \$5,000,000 aggregate, including bodily injury (including wrongful death), property damage, products, personal & advertising injury, and completed operations. This insurance must provide coverage for all Claims that may arise from the services and/or operations completed under this Contract, whether such services or operations are by Contractor or anyone directly or indirectly employed by them. Such insurance(s) shall also be primary and non-contributory with regard to insurance carried by the Additional Insureds.

The Contractor shall procure and maintain during the life of this Contract, Comprehensive Automobile Liability Insurance with minimum limits of \$2,000,000 combined single limit for bodily injury and property damage liability and insuring liability arising out of or in any way related directly or indirectly to the ownership, maintenance or use of any owned, non-owned or rented/hired automobiles.

The Contractor shall procure and maintain during the life of this Contract, adequate Workers' Compensation Insurance in at least such amounts as are required by the law for all of its employees per Florida Statute 440.02.

The required insurance limits identified above may be satisfied by a combination of a primary policy and/or Umbrella or Excess Liability Insurance policy.

Providing and maintaining adequate insurance coverage is a material obligation of Contractor. County has no obligation or duty to advise Contractor of any non-compliance with the insurance requirements contained in this Section. If Contractor fails to obtain and maintain all of the insurance coverages required herein, Contractor shall indemnify and hold harmless the Additional Insureds from and against any and all Claims that would have been covered by such insurance had Contractor complied with its obligations herein.

County reserves the right to adjust the above minimum insurance requirements or require additional insurance coverages to address other insurable hazards.

35) GOVERNING LAWS & REGULATIONS

The Contractor shall be responsible for being familiar and complying with any and all federal, state, and local laws, ordinances, rules and regulations that, in any manner, affect the work required under this contract. The agreement shall be governed by the laws of the State of Florida and St. Johns County both as to interpretation and performance.

For the projects awarded under this contract relating to an Emergency declaration, the Contractor will comply with the strictest provisions of Federal 2 CFR 200, State, and Local procurement Rules, Regulations and/or Ordinances, etc.

36) EMPLOYMENT ELIGIBILITY AND MANDATORY USE OF E-VERIFY

As a condition precedent to entering into this Agreement, and in accordance with section 448.095, F.S., Contractor and its subcontractors shall register with and use the E-Verify system to verify the work authorization status of all employees hired on or after January 1, 2021.

- a. Contractor shall require each of its subcontractors to provide Contractor with an affidavit stating that the subcontractor does not employ, contract with, or subcontract with an unauthorized alien. Contractor shall maintain a copy of such affidavit for the duration of this Agreement.
- b. The County, Contractor, or any subcontractor who has a good faith belief that a person or entity with which it is contracting has knowingly violated section 448.09(1), F.S. or these provisions regarding employment eligibility shall terminate the contract with the person or entity.
- c. The County, upon good faith belief that a subcontractor knowingly violated these provisions regarding employment eligibility, but Contractor otherwise complied, shall promptly notify Contractor and Contractor shall immediately terminate the contract with the subcontractor.

- d. The County and Contractor hereby acknowledge and mutually agree that, a contract terminated pursuant to these provisions regarding employment eligibility is not a breach of contract and may not be considered as such. Any contract terminated pursuant to these provisions regarding employment eligibility may be challenged in accordance with section 448.095(2)(d), F.S.
- e. Contractor acknowledges that, in the event that the County terminates this Contract for Contractor's breach of these provisions regarding employment eligibility, then Contractor may not be awarded a public contract for at least one (1) year after such termination. Contractor further acknowledges that Contractor is liable for any additional costs incurred by the County as a result of the County's termination of this Agreement for breach of these provisions regarding employment eligibility.
- f. Contractor shall incorporate in all subcontracts made pursuant to this Agreement the provisions contained herein regarding employment eligibility.

37) PUBLIC RECORDS

- A. The cost of reproduction, access to, disclosure, non-disclosure, or exemption of records, data, documents, and/or materials, associated with this Agreement shall be subject to the applicable provisions of the Florida Public Records Law (Chapter 119, Florida Statutes), and other applicable State and Federal provisions. Access to such public records, may not be blocked, thwarted, and/or hindered by placing the public records in the possession of a third party, or an unaffiliated party.
- B. In accordance with Florida law, to the extent that Contractor's performance under this Contract constitutes an act on behalf of the County, Contractor shall comply with all requirements of Florida's public records law. Specifically, if Contractor is expressly authorized, and acts on behalf of the County under this Agreement, Contractor shall:
 - (1) Keep and maintain public records that ordinarily and necessarily would be required by the County in order to perform the Services;
 - (2) Upon request from the County's custodian of public records, provide the County with a copy of the requested records or allow the records to be inspected or copied within a reasonable time at a cost that does not exceed the cost as provided in Chapter 119, Florida Statutes, or as otherwise provided by law;
 - (3) Ensure that public records related to this Agreement that are exempt or confidential and exempt from public records disclosure requirements are not disclosed except as authorized by applicable law for the duration of this Agreement and following completion of this Agreement if the Contractor does not transfer the records to the County; and
 - (4) Upon completion of this Agreement, transfer, at no cost, to the County all public records in possession of the Contractor or keep and maintain public records required by the County to perform the Services.

If the Contractor transfers all public records to the County upon completion of this Agreement, the Contractor shall destroy any duplicate public records that are exempt or confidential and exempt from public records disclosure requirements. If the Contractor keeps and maintains public records upon completion of this Agreement, the Contractor shall meet all applicable requirements for retaining public records. All records stored electronically must be provided to the County, upon request from the County's custodian of public records, in a format that is compatible with the County's information technology systems.

Failure by the Contractor to comply with the requirements of this section shall be grounds for immediate, unilateral termination of this Agreement by the County.

IF THE CONTRACTOR HAS QUESTIONS REGARDING THE APPLICATION OF CHAPTER 119, FLORIDA STATUTES, TO ITS DUTY TO PROVIDE PUBLIC RECORDS RELATING TO THIS AGREEMENT, CONTACT THE CUSTODIAN OF PUBLIC RECORDS AT:

**500 San Sebastian View
St. Augustine, FL 32084
(904) 209-0805
publicrecords@sjcfl.us**

END OF SECTION

**OFFICIAL COUNTY BID FORM
WITH ATTACHMENTS**

BID NO: 23-94; CR 210 Widening from Trinity Way to Beachwalk Boulevard

**OFFICIAL COUNTY BID FORM
ST. JOHNS COUNTY, FLORIDA**

TO: THE BOARD OF COUNTY COMMISSIONERS OF ST. JOHNS COUNTY, FLORIDA

DATE SUBMITTED: _____

BID PROPOSAL OF

Full Legal Company Name

Mailing Address

Telephone Number

Fax Number

Bidders: Having become familiar with requirements of the project, and having carefully examined the Bidding Documents and Specifications entitled for Bid No: 23-94; CR 210 Widening from Trinity Way to Beachwalk Boulevard in St. Johns County, Florida, the undersigned proposes to furnish all materials, labor and equipment, supervision and all other requirements necessary to comply with the Contract Documents to submit the following Bid Proposal summarized as follows:

Total Lump Sum Bid: 18 Months Completion Time: (As per Exhibit A – CR 210 Widening from Trinity Way to Beachwalk Boulevard Construction Plans – Dated February 23, 2023). The Base Bid includes all work to construct the project from Trinity Way to Beachwalk Boulevard, as shown on the base bid plan sheets.

\$ _____
Lump Sum Bid Price (Numerical)

_____/100 Dollars
Lump Sum Bid Price (Amount written or typed in words)

Bidder shall insert the Lump Sum Bid Price above, in numerals and in words. In the event of a discrepancy between the two, the amount shall be determined by the amount written in words.

Alternate #1: 15 Months Completion Time Total Lump Sum Bid: (As per Exhibit A – CR 210 Widening from Trinity Way to Beachwalk Boulevard Construction Plans – Dated February 23, 2023). The Base Bid includes all work to construct the project from Trinity Way to Beachwalk Boulevard, as shown on the base bid plan sheets.

\$ _____
Lump Sum Bid Price (Numerical)

_____/100 Dollars
Lump Sum Bid Price (Amount written or typed in words)

Bidder shall insert the Lump Sum Bid Price above, in numerals and in words. In the event of a discrepancy between the two, the amount shall be determined by the amount written in words.

BID NO: 23-94; CR 210 Widening from Trinity Way to Beachwalk Boulevard

During the preparation of the Bid, the following addenda, if any, were received:

No.: _____ Date Received:

No.: _____ Date Received:

No.: _____ Date Received:

We, the undersigned, hereby declare that no person or persons, firm or corporation, other than the undersigned are interested, in this proposal, as principals, and that this proposal is made without collusion with any person, firm or corporation, and we have carefully and to our satisfaction examined the Bid Documents and Project Specifications.

We have made a full examination of the location of the proposed work and the sources of supply of materials, and we hereby agree to furnish all necessary labor, equipment and materials, fully understanding that any quantities shown therewith are approximate only, and that we will fully complete all requirements therein as prepared by the County, within the same time limit specified in the Bid Documents as indicated above.

If the Undersigned is notified of the acceptance of this Bid Proposal by the Board within ninety (90) calendar days for the time set for the opening of Bids, the Undersigned further agrees, to execute a contract for the above work within ten (10) days after notice that his Bid has been accepted for the above stated compensation in the form of a Contract presented by the County.

The Undersigned further agrees that security in the form of a Bid Bond, certified or cashier's check in the amount of not less than **five percent (5%) of Total Lump Sum Bid Price**, payable to the County, accompanies this Bid; that the amount is not to be construed as a penalty, but as liquidated damages which said County will sustain by failure of the Undersigned to execute and deliver the Contract and Bond within ten (10) days of the written notification of the Award of the Contract to him; thereupon, the security shall become the property of the County, but if this Bid is not accepted within ninety (90) days of the time set for the submission of Bids, or if the Undersigned delivers the executed Contract upon receipt, the Security shall be returned to the Bidder within seven (7) working days.

BID NO: 23-94; CR 210 Widening from Trinity Way to Beachwalk Boulevard

CORPORATE/COMPANY

Full Legal Company Name: _____(Seal)

By: _____
Signature of Authorized Representative (Name & Title typed or printed)

By: _____
Signature of Authorized Representative (Name & Title typed or printed)

Address: _____

Telephone No.: (____) _____ Fax No.: (____) _____

Email Address for Authorized Company Representative: _____

Federal I.D. Tax Number: _____ DUNS #: _____
(If applicable)

INDIVIDUAL

Name: _____ (Signature)
(Name typed or printed) (Title)

Address: _____

Telephone No.: (____) _____ Fax No.: _____

Email Address: _____

Federal I.D. Tax Number: _____

Each Bidder must submit all required forms and attachments. Failure to submit any required document may be grounds for disqualification due to non-responsiveness.

Submittal Requirements: Official County Bid Form, and all Attachments must be completed; along with a fully acknowledged copy of each Addendum applicable to this Bid and submitted with each copy of the Bid Proposal.

BID NO: 23-94; CR 210 Widening from Trinity Way to Beachwalk Boulevard

ATTACHMENT "A"

ST. JOHNS COUNTY AFFIDAVIT

Bidder shall complete and submit a sworn statement as part of the submitted Bid. This sworn statement shall be an Affidavit in the following form, executed by an officer/principal of the Bidder, and shall be sworn to before a person who is authorized by law to administer oaths.

STATE OF _____

COUNTY OF _____

The Undersigned authority, _____ ("Affiant"), who being duly sworn, deposes and states that he/she is the _____ (Title) of the Bidder _____ (Full Legal Name of Bidder) submitting the attached Bid for the services provided in the Bid Documents for Bid No: 23-94; CR 210 Widening from Trinity Way to Beachwalk Boulevard, in St. Johns County, Florida.

The Affiant further states that no more than one Bid for the above-referenced project will be submitted from the Bidder, the Affiant, their firm or corporation under the same or different name, and that such Bidder has no financial interest in the firm of another Bidder for the same work. Affiant also states that neither he/she, the firm, association nor corporation of the Bidder has either directly or indirectly entered into any agreement, participated in any collusion, nor otherwise taken any action in restraint of free competitive bidding in connection with this firm's Bid on the above-described project. Furthermore, neither the firm nor any of its officers are barred from participating in public contract lettings in the State of Florida or any other state.

DATED this _____ day of _____, 20____.

Signature of Affiant

Printed Name of Affiant

Printed Title of Affiant

Full Legal Name of Consultant/Contractor

Sworn to (or affirmed) and subscribed before me by means of physical presence or online notarization, this _____ day of _____, 20____, by _____, who is personally known to me or has produced _____ as identification.

Notary Public
My Commission Expires: _____

BIDDER MUST EXECUTE AND ATTACH THIS AFFADAVIT TO SUBMITTED BID.

ATTACHMENT "B"

CERTIFICATES AS TO CORPORATE PRINCIPAL

I, _____, certify that I am the Secretary of the corporation named as Principal in the foregoing; that _____, (Authorized Representative of Bidder) who signed the Bond(s) on behalf of the Bidder, was then _____ (Title) of said corporation; that I know his/her signature; and his/her signature thereto is genuine; and that said bond(s) was duly signed, sealed, and attested to on behalf of said corporation by authority of its governing body.

Signature of Secretary

Full Legal Name of Corporation (Bidder)

STATE OF _____

COUNTY OF _____

Before and by me, a Notary Public duly commissioned, qualified and acting personally, being duly sworn upon oath by means of physical presence or online notarization, _____ (Authorized Representative of Bidder) states that he/she is authorized to execute the foregoing Bid Bond on behalf of the Bidder named therein in favor of St. Johns County, Florida.

Subscribed and sworn to me on this ___ day of _____, 20___, by the Authorized Representative of Bidder, who is personally known to me or has produced _____ as identification. Type and Number of I.D. produced: _____.

Notary Public
My Commission Expires: _____

(Attach Power of Attorney to original Bid Bond and Financial Statement of Surety Company)

ATTACHMENT "C"

CONTRACTOR'S QUALIFICATIONS STATEMENT

I, _____ hereby certify that _____
(Authorized Company Representative Name & Title) (Full Legal Company Name)

has performed and is licensed in the State of Florida as a Certified General Contractor (CGC) or a Certified Underground Utility and Excavation Contractor (CUC). I also certify that the above named company is capable of bonding any Contract in excess of \$100,000.00 in value and shall perform the scope of work in accordance with the specifications stated in this Bid and that all information being submitted in response to this request is true and accurate to the best of my knowledge.

Authorized Bidder Representative:

Signature Date

Name & Title of Representative

BID NO: 23-94; CR 210 Widening from Trinity Way to Beachwalk Boulevard

ATTACHMENT "D"

LICENSE / CERTIFICATION LIST

In the space below, the Bidder shall list all **current** licenses and certifications held, and FDOT Pre-qualification Letters for required FDOT Work Classes.

The bidder shall attach a copy of each current license, certifications, and/or FDOT pre-qualification letters listed below to this form.

License(s)/Certificate(s)/ Pre-Qualifications	License #	Issuing Agency	Expiration Date
State of Florida Business License			
Certified General Contractor (CGC)			
Certified Underground Utility and Excavation Contractor (CUC)			
FDOT Pre-Qualification (7) – Drainage			
FDOT Pre-Qualification (10) – Flexible Paving			
FDOT Pre-Qualification (11) – Grading			
FDOT Pre-Qualification (28) – Pavement Marking			
FDOT Pre-Qualification (38) – Roadway Signing			
FDOT Pre-Qualification (40) – Sidewalk			

BID NO: 23-94; CR 210 Widening from Trinity Way to Beachwalk Boulevard

ATTACHMENT "E"

LIST OF PROPOSED SUB-CONTRACTORS / SUPPLIERS

Bidder shall submit any and all sub-contractors and/or major material suppliers proposed to perform any portion of the Work for review/approval by the County. Bidder shall attach any and all applicable licenses or certifications held by the proposed sub-contractor/supplier related to the portion of the Work for which they are proposed, as stated below. All subcontractors/suppliers are subject to the approval of the County.

Company Name	Work/Services to be Performed	Primary Contact Name	Contact Number and Email Address	Local Business (Yes/No)	Percentage (%) of Total Work/Services

ATTACHMENT "F"

St. Johns County Board of County Commissioners

CONFLICT OF INTEREST DISCLOSURE FORM

Project BID Number/Description: Bid No 23-94; CR 210 Widening from Trinity Way to Beachwalk Boulevard

The term "conflict of interest" refers to situations in which financial or other considerations may adversely affect, or have the appearance of adversely affecting a consultant's/contractor's professional judgment in completing work for the benefit of St. Johns County ("County"). The bias such conflicts could conceivably impart may inappropriately affect the goals, processes, methods of analysis or outcomes desired by the County.

Consultants/Contractors are expected to safeguard their ability to make objective, fair, and impartial decisions when performing work for the benefit of the County. Consultants/Contractors, therefore must there avoid situations in which financial or other considerations may adversely affect, or have the appearance of adversely affecting the consultant's/contractor's professional judgement when completing work for the benefit of the County.

The mere appearance of a conflict may be as serious and potentially damaging as an actual distortion of goals, processes, methods of analysis or outcomes. Reports of conflicts based upon appearances can undermine public trust in ways that may not be adequately restored even when the mitigating facts of a situation are brought to light. Apparent conflicts, therefore, should be disclosed and evaluated with the same vigor as actual conflicts.

It is expressly understood that failure to disclose conflicts of interest as described herein may result in immediate disqualification from evaluation or immediate termination from work for the County.

Please check the appropriate statement:

I hereby attest that the undersigned Respondent has no actual or potential conflict of interest due to any other clients, contracts, or property interests for completing work on the above referenced project.

The undersigned Respondent, by attachment to this form, submits information which may be a potential conflict of interest due to other clients, contracts or property interests for completing work on the above referenced project.

Legal Name of Respondent: _____

Authorized Representative(s): _____

Signature

Print Name/Title

Signature

Print Name/Title

St. Johns County Board of County Commissioners

ATTACHMENT "G"

DRUG-FREE WORKPLACE FORM

The undersigned firm, in accordance with Florida Statute 287.087 hereby certifies that

_____ does:

Name of Firm

1. Publish a statement notifying employees that the unlawful manufacture, distribution, dispensing, possession or use of a controlled substance is prohibited in the workplace and specifying the actions that will be taken against employees for violations of such prohibition.
2. Inform employees about the danger of drug abuse in the workplace, the business' policy of maintaining a drug-free workplace, any available drug counseling, rehabilitation, employee assistance programs and the penalties that may be imposed upon employees for drug abuse violations.
3. Give each employee engaged in providing the contractual services that are described in St. Johns County's request for proposals a copy of the statement specified in paragraph 1.
4. In the statement specified in paragraph 1, notify the employees that, as a condition of working on the contractual services described in paragraph 3, the employee will abide by the terms of the statement and will notify the employer of any conviction of, or plea of guilty or nolo contendere to, any violation of Florida Statute 893, as amended, or of any controlled substance law of the United States or any state, for a violation occurring in the workplace no later than five (5) days after such conviction or plea.
5. Impose a sanction on, or require the satisfactory participation in a drug abuse assistance or rehabilitation program if such is available in the employee's community by, any employee who is so convicted.
6. Consistent with applicable provisions with State or Federal law, rule, or regulation, make a good faith effort to continue to maintain a drug-free workplace through implementation of paragraphs 1 through 5.

As the person authorized to sign this statement, I certify that this firm complies fully with the above requirements.

Signature

Date

BID NO: 23-94; CR 210 Widening from Trinity Way to Beachwalk Boulevard

ATTACHMENT "H"

CERTIFICATE(S) OF INSURANCE
(Attach or insert copy here)

Respondents shall provide certificates of insurance as part of their submittal package. Certificates of insurance shall meet or exceed the requirements as described under Insurance.

Failure to provide proof of current insurance coverage or ability to obtain the required coverages may result in being deemed non-responsive and removed from further consideration.

BID NO: 23-94; CR 210 Widening from Trinity Way to Beachwalk Boulevard

ATTACHMENT "1"

RELEVANT EXPERIENCE OF BIDDER

Each Bidder must submit a list of projects showing relevant experience for the past five (5) years to the scope as described in this IFB. The information required shall include: dates of service, dollar amount of contract, name of individual, firm or agency, and a contact person name, title, phone number and email address. The County reserves the right to contract the project owners to verify experience of the Bidder.

ATTACHMENT "J"

CLAIMS, LIENS, LITIGATION HISTORY

Bidders must complete all questions below and provide information requested as applicable. Failure to appropriately complete the questions below, or provide requested information may be grounds for disqualification. Any material misrepresentation of information may also be grounds for disqualification.

1. Within the past 7 years, has your organization filed suit or a formal claim against a project owner (as a prime or subcontractor) or been sued by or had a formal claim filed by an owner, subcontractor or supplier resulting from a project dispute?

Yes _____ No _____

If yes, please attach additional sheet(s) to include:

- Description of every action Captions of the Litigation or Arbitration
- Amount at issue
- Name (s) of the attorneys representing all parties:
- Amount actually recovered, if any
- Name(s) of the project owner(s)/manager(s) to include address and phone number

2. List all pending litigation and or arbitration.
3. List and explain all litigation and arbitration within the past seven (7) years - pending, resolved, dismissed, etc.
4. Please list all liens (including Federal, State, and Local) which have been filed against your Company within the past seven (7) years. List in detail the type of Lien, date, amount and current status of each Lien. If none, so state.

5. Have you ever abandoned a job, been terminated or had a performance/surety bond called to complete a job?
Yes _____ No _____ If yes, on separate sheet(s), provide an explanation of those instances.
6. For all claims filed against your company within the past five (5) years, have all been resolved satisfactorily with final judgment in favor of your company within 90 days of the date the judgment became final?

Yes _____ No _____ If no, on separate sheet(s), explain why.

7. On separate sheet(s), list the status of all pending claims currently filed against your company. If none, so state.
8. Has a project owner ever withheld retainage, issued liquidated damages or made a claim against any Performance and Payment Bonds?

Yes _____ No _____ If yes, on separate sheet(s) explain in detail.

ATTACHMENT "K"

SWORN STATEMENT UNDER SECTION 287.133(3)(A), FLORIDA STATUTES ON PUBLIC ENTITY CRIMES

I, _____ ("Affiant"), being duly authorized by and on behalf of _____
_____ ("Respondent") hereby swears or affirms as follows:

1. The principal business address of Respondent is: _____

2. I am duly authorized as _____ (Title) of Respondent.
3. I understand that a public entity crime as defined in Section 287.133 of the Florida Statutes includes a violation of any state or federal law by a person with respect to and directly related to the transaction of business with any public entity in Florida or with an agency or political subdivision of any other state or with the United States, including, but not limited to, any bid, proposal, reply, or contract for goods or services, any lease for real property, or any contract for the construction or repair of a public building or public work, involving antitrust, fraud, theft, bribery, collusion, racketeering, conspiracy, or material misrepresentation.
4. I understand that "convicted" or "conviction" is defined in Section 287.133 of the Florida Statutes to mean a finding of guilt or a conviction of a public entity crime, with or without an adjudication of guilt, in any federal or state trial court of record relating to charges brought by indictment or information after July 1, 1989, as a result of a jury verdict, non-jury trial, or entry of a plea of guilt or nolo contendere.
5. I understand that "affiliate" is defined in Section 287.133 of the Florida Statutes to mean (1) a predecessor or successor of a person or a corporation convicted of a public entity crime, or (2) an entity under the control of any natural person who is active in the management of the entity and who has been convicted of a public entity crime, or (3) those officers, directors, executives, partners, shareholders, employees, members, and agents who are active in the management of an affiliate, or (4) a person or corporation who knowingly enters into a joint venture with a person who has been convicted of a public entity crime in Florida during the preceding 36 months.
6. Neither the Respondent, nor any officer, director, executive, partner, shareholder, employee, member or agent who is active in the management of the Offeror or contractor, nor any affiliate of the Offeror or contractor has been convicted of a public entity crime subsequent to July 1, 1989. **(Draw a line through paragraph 6 if paragraph 7 below applies.)**
7. There has been a conviction of a public entity crime by the Respondent, or an officer, director, executive, partner, shareholder, employee, member or agent of the Respondent who is active in the management of the Respondent or an affiliate of the Respondent. A determination has been made pursuant to Section 287.133(3) by order of the Division of Administrative Hearings that it is not in the public interest for the name of the convicted person or affiliate to appear on the convicted vendor list. The name of the convicted person or affiliate is _____. A copy of the order of the Division of Administrative Hearings is attached to this statement. **(Draw a line through paragraph 7 if paragraph 6 above applies.)**

Signature of Affiant

Printed Name & Title of Affiant

Full Legal Name of Respondent

Date of Signature

Sworn to (or affirmed) and subscribed before me by means of physical presence or online notarization, this _____ day of _____, 20__, by Affiant, who is personally known to me or has produced _____ as identification.

Notary Public

My Commission Expires

ATTACHMENT "L"

NON-COLLUSION CERTIFICATION

St. Johns County requires, as a matter of policy, that any Firm receiving a contract or award resulting from the Invitation for Bid issued by St. Johns County shall make certification as below. Receipt of such certification, under oath, shall be a prerequisite to the award of contract and payment thereof.

I (we) hereby certify that if the contract is awarded to me, our firm, partnership or corporation, that no members of the elected governing body of St. Johns County nor any professional management, administrative official or employee of the County, nor members of his or her immediate family including spouse, parents or children, nor any person representing or purporting to represent any member or members of the elected governing body or other official, has solicited, has received or has been promised, directly or indirectly, any financial benefit including but not limited to a fee, commission, finder's fee, political contribution, goods or services in return for favorable review of any Bids submitted in response to the Invitation for Bid or in return for execution of a contract for performance or provision of services for which Bids are herein sought.

Handwritten Signature of Authorized Principal(s):

NAME (print): _____

SIGNATURE: _____

TITLE: _____

DATE: _____

NAME OF FIRM/PARTNERSHIP/CORPORATION:

BID NO: 23-94; CR 210 Widening from Trinity Way to Beachwalk Boulevard

ATTACHMENT "M"

E-VERIFY AFFIDAVIT

STATE OF _____
COUNTY OF _____

I, _____ (hereinafter "Affiant"), being duly authorized by and on behalf of _____ (hereinafter "Consultant/Contractor") hereby swears or affirms as follows:

1. Consultant/Contractor understands that E-Verify, authorized by Illegal Immigration Reform and Immigrant Responsibility Act of 1996 (IIRIRA), is a web-based system provided by the United States Department of Homeland Security, through which employers electronically confirm the employment eligibility of their employees.
2. For the duration of Contract No. _____ (hereinafter "Agreement"), in accordance with section 448.095, F.S., Consultant/Contractor shall utilize the U.S. Department of Homeland Security's E-Verify system to verify the employment eligibility of all new employees hired by the Consultant/Contractor and shall expressly require any subcontractors performing work or providing services pursuant to the Agreement to likewise utilize the U.S. Department of Homeland Security's E-Verify system to verify the employment eligibility of all new employees hired by the subcontractor.
3. Consultant/Contractor shall comply with all applicable provisions of section 448.095, F.S., and will incorporate in all subcontracts the obligation to comply with section 448.095, F.S.
4. Consultant/Contractor understands and agrees that its failure to comply with all applicable provisions of section 448.095, F.S. or its failure to ensure that all employees and subcontractors performing work under the Agreement are legally authorized to work in the United States and the State of Florida constitute a breach of the Agreement for which St. Johns County may immediately terminate the Agreement without notice and without penalty. The Consultant/Contractor further understands and agrees that in the event of such termination, Consultant/Contractor shall be liable to the St. Johns County for any costs incurred by the St. Johns County resulting from Consultant/Contractor's breach.

DATED this _____ day of _____, 20____.

Signature of Affiant

Printed Name of Affiant

Printed Title of Affiant

Full Legal Name of Consultant/Contractor

Sworn to (or affirmed) and subscribed before me by means of physical presence or online notarization, this _____ day of _____, 20____, by _____, who is personally known to me or has produced _____ as identification.

Notary Public
My Commission Expires: _____

ATTACHMENT "N"

CERTIFICATE OF COMPLIANCE WITH FLORIDA TRENCH SAFETY ACT

Bidder acknowledges that he is solely responsible for complying with the Florida Trench Safety Act (ACT) and Occupational Safety and Health Administrations excavation safety standard 29 CFR 1926.650 (Subpart P as amended) and the St. Johns County Trenching and Excavation Safety Program. If there is a conflict between the ACT and the St. Johns County Trenching and Excavation Safety Program, the more stringent requirement would apply. Bidder further acknowledges that included in the various items of the proposal and in the Total Bid Price are costs for complying with the Florida Trench Safety Act (90-96, Laws of Florida) effective October 1, 1990 and the Occupational Safety and Health Administrations excavation safety standard.

Handwritten Signature of Authorized Principal(s):

NAME (print): _____

SIGNATURE: _____

TITLE: _____

DATE: _____

NAME OF FIRM/PARTNERSHIP/CORPORATION:

BID NO: 23-94; CR 210 Widening from Trinity Way to Beachwalk Boulevard

ATTACHMENT "O"

LOCAL PREFERENCE

Bidders must complete and submit **Attachment O**, indicating whether or not the Bidder is submitting for consideration of Local Preference. Any Bidder that meets the criteria of a Local Business, in accordance with Section 16.3.1 of the SJC Purchasing Policy, must submit all documentation required to support consideration as Local Business, for the Bidder as well as any proposed sub-contractors who are submitted for consideration of Local Preference as specified on Attachment O.

Any Bidder submitting for consideration of Local Preference either through their own qualifications, or through that of proposed sub-contractors must also submit documentation to demonstrate that at least fifty percent (50%) of all Work shall be self-performed, or performed by sub-contractors that meet the criteria of a Local Business.

In order to qualify for local preference Bidder must provide sufficient documentation to demonstrate:

- A physical, brick and mortar place of business located within the geographic boundaries of St. Johns County, with a valid mailing address, in an area zoned for the conduct of such business, from which the Bidder has operated or performed business on a day-to-day basis that is substantially similar to those specified in the solicitation for a period of at least one (1) calendar year prior to the issuance of the solicitation. No PO Boxes shall be accepted.
- Local address above must be registered as the Bidder's principal place of business with the Divisions of Corporations Florida Department of State for at least one (1) calendar year prior to the issuance of this RFQ.
- Submit current and valid Local Business Tax Receipt, and must have Local Business Tax Receipts issued by the St. Johns County Tax Collector from at least one (1) calendar year prior to issuance of this RFQ.
- Must qualify as a local business as shown above **AND** self-perform a minimum of fifty percent (50%) of all services under the awarded Contract, or must have a minimum of fifty percent (50%) of all services performed by qualified local businesses as sub-contractors.

Bidder is a Local Business as defined in Section 16.3.1, SJC Purchasing Policy _____

If Bidder selects this option, by signing below, Bidder certifies that the firm qualifies as a local business in accordance with the requirements stated above, OR certifies that the submitted local business proposed as sub-contractors meet the requirements for local preference AND that a minimum of fifty percent (50%) of all services shall be performed by local businesses as proposed.

Bidder is not a Local Business as defined in Section 16.3.1, SJC Purchasing Policy _____

If Bidder selects this option, Bidder is not seeking consideration for local preference, and is not required to submit the documentation provided above.

Signature – Authorized Representative

Printed Name & Title

Date of Signature

BID NO: 23-94; CR 210 Widening from Trinity Way to Beachwalk Boulevard

ATTACHMENT "P"

SCHEDULE OF VALUES - EIGHTEEN (18) MONTHS COMPLETION TIME

Bidders shall complete and submit with their Bid Proposal this Schedule of Values to demonstrate the breakdown of costs included in the submitted Lump Sum Bid Price. Quantities provided herein are estimates only and Bidders are responsible for appropriately estimating quantities for inclusion in the submitted Lump Sum Bid Price.

Bid Item	Pay Item	Description	Quantity	Unit	Cost Per Unit	Total Cost
General						
1	101 1	MOBILIZATION	1	LS	\$	\$
2	104 10 3	SEDIMENT BARRIER	6004	LF	\$	\$
3	104 12	STAKED TURBIDITY BARRIER	690	LF	\$	\$
4	104 18	INLET PROTECTION SYSTEM	51	EA	\$	\$
5	110 1 1	CLEARING AND GRUBBING	12.47	AC	\$	\$
6	110 4 10	REMOVAL OF EXISTING CONCRETE	2018	SY	\$	\$
General Sub-Total						\$
Roadway						
7	120 1	REGULAR EXCAVATION	3560	CY	\$	\$
8	120 6	EMBANKMENT	21194	CY	\$	\$
9	160 4	TYPE B STABILIZATION	40728	SY	\$	\$
10	285 711	OPTIONAL BASE GROUP 11, 12" LIMEROCK	36118	SY	\$	\$
11	327 70 6	MILLING EXISTING ASPHALT PAVEMENT, 1 1/2" AVG DEPTH	5,217	SY	\$	\$
12	334 1 12	SUPERPAVE ASPHALT PAVEMENT, TRAFFIC B (3")	5,960	TN	\$	\$
13	337 7 80	ASPHALT CONCRETE FRICTION COURSE, TRAFFIC B, FC-9.5, PG 76-22 (1.5")	3,410	TN	\$	\$
14	520 1 10	CONCRETE CURB & GUTTER, TYPE F	9,005.00	LF	\$	\$
15	520 5 41	TRAFFIC SEPARATOR CONCRETE - TYPE IV, 4' WIDE	1,396.00	LF	\$	\$
16	522 1	CONCRETE SIDEWALK AND DRIVEWAYS, 4" THICK	3,252	SY	\$	\$
17	522 2	CONCRETE SIDEWALK AND DRIVEWAYS, 6" THICK	729	SY	\$	\$
18	527 2	DETECTABLE WARNINGS	337	SF	\$	\$
19	570 1 1	PERFORMANCE TURF	13,990	SY	\$	\$
20	570 1 2	PERFORMANCE TURF, SOD	6,012	SY	\$	\$
Roadway Sub-Total						\$
Drainage						
21	425 1 311	INLETS, CURB, TYPE P-1, <10'	9.00	EA	\$	\$
22	425 1 315	INLETS, CURB, TYPE P-1, PARTIAL	2.00	EA	\$	\$
23	425 1 321	INLETS, CURB, TYPE P-2, <10'	7.00	EA	\$	\$
24	425 1 411	INLETS, CURB, TYPE J-1, <10'	2.00	EA	\$	\$
25	425 1 412	INLETS, CURB, TYPE J-1, >10'	4.00	EA	\$	\$
26	425 1 421	INLETS, CURB, TYPE J-2, <10'	6.00	EA	\$	\$

27	425 1 471	INLETS, CURB, TYPE 7, <10'	5.00	EA	\$	\$
28	425 1 521	INLETS, DT BOT, TYPE C, <10'	2.00	EA	\$	\$
29	425 1 541	INLETS, DT BOT, TYPE D, <10'	5.00	EA	\$	\$
30	425 2 61	MANHOLES, P-8, <10'	1.00	EA	\$	\$
31	425 2 92	MANHOLES, J-8, >10'	5.00	EA	\$	\$
32	430 175 118	PIPE CULVERT, OPTIONAL MATERIAL, ROUND 18"	1,318.00	LF	\$	\$
33	430 175 124	PIPE CULVERT, OPTIONAL MATERIAL, ROUND 24"	274.00	LF	\$	\$
34	430 175 130	PIPE CULVERT, OPTIONAL MATERIAL, ROUND 30"	476.00	LF	\$	\$
35	430 175 136	PIPE CULVERT, OPTIONAL MATERIAL, ROUND 36"	746.00	LF	\$	\$
36	430 175 142	PIPE CULVERT, OPTIONAL MATERIAL, ROUND 42"	843.00	LF	\$	\$
37	430 175 148	PIPE CULVERT, OPTIONAL MATERIAL, ROUND 48"	855.00	LF	\$	\$
38	430 174 218	PIPE CULVERT, OPTIONAL MATERIAL, OTHER SHAPE, ELLIP/ARCH, 18"	442.00	LF	\$	\$
39	430 174 224	PIPE CULVERT, OPTIONAL MATERIAL, OTHER SHAPE, ELLIP/ARCH, 24"*	322.00	LF	\$	\$
40	430 530 100	STRIAGHT CONCRETE ENDWALL, 30", SINGLE, 0 DEG, ROUND	2.00	EA	\$	\$
41	430 984 625	MITERED END SECTION, OPTIONAL - ELLIP/ARCH, 18"	6.00	EA	\$	\$
42	430 984 629	MITERED END SECTION, OPTIONAL - ELLIP/ARCH, 24"	2.00	EA	\$	\$
Drainage Sub-total						\$
Signing and Pavement Marking						
43	700 1 11	SINGLE POST SIGN, F&I GROUND MOUNT, UP TO 12 SF	9.00	AS	\$	\$
44	700 1 12	SINGLE POST SIGN, F&I GROUND MOUNT, 12-20 SF	1.00	AS	\$	\$
45	700 1 50	SINGLE POST SIGN, RELOCATE	1.00	AS	\$	\$
46	700 1 60	SINGLE POST SIGN, REMOVE	14.00	AS	\$	\$
47	705 11 1	DELINEATOR, FLEXIBLE TUBULAR	5.00	EA	\$	\$
48	706 1 3	RAISED PAVEMENT MARKER, TYPE B	721.00	EA	\$	\$
49	711 11 102	THERMOPLASTIC, STANDARD, WHITE, SOLID 8"	0.08	GM	\$	\$
50	711 11 123	THERMOPLASTIC, STANDARD, WHITE, SOLID 12"	1,417.00	LF	\$	\$
51	711 11 124	THERMOPLASTIC, STANDARD, WHITE, SOLID 18"	513.00	LF	\$	\$
52	711 11 125	THERMOPLASTIC, STANDARD, WHITE, SOLID 24"	313.00	LF	\$	\$
53	711 11 141	THERMOPLASTIC, STANDARD, WHITE, 2-4 DOTTED GUIDELINE, 6"	0.16	GM	\$	\$

54	711 11 160	THERMOPLASTIC, PREFORMED, WHITE, MESSAGE	18.00	EA	\$	\$
55	711 11 170	THERMOPLASTIC, PREFORMED, WHITE, ARROW	64.00	EA	\$	\$
56	711 11 224	THERMOPLASTIC, STANDARD, YELLOW, SOLID 18"	170.00	LF	\$	\$
57	711 15 101	THERMOPLASTIC, STANDARD OG ASPHALT, WHITE, SOLID, 6"	2.63	GM	\$	\$
58	711 15 131	THERMOPLASTIC, STANDARD OG ASPHALT, WHITE, SKIP, 6" 10-30 SKIP	1.92	GM	\$	\$
59	711 15 201	THERMOPLASTIC, STANDARD OG ASPHALT, YELLOW, SOLID, 6"	1.45	GM	\$	\$
Signing and Pavement Marking Sub-Total						\$
Total Lump Sum Bid Price						\$

BID NO: 23-94; CR 210 Widening from Trinity Way to Beachwalk Boulevard

ATTACHMENT "Q"

SCHEDULE OF VALUES - FIFTEEN (15) MONTHS COMPLETION TIME

Bidders shall complete and submit with their Bid Proposal this Schedule of Values to demonstrate the breakdown of costs included in the submitted Lump Sum Bid Price. Quantities provided herein are estimates only and Bidders are responsible for appropriately estimating quantities for inclusion in the submitted Lump Sum Bid Price.

Bid Item	Pay Item	Description	Quantity	Unit	Cost Per Unit	Total Cost
General						
1	101 1	MOBILIZATION	1	LS	\$	\$
2	104 10 3	SEDIMENT BARRIER	6004	LF	\$	\$
3	104 12	STAKED TURBIDITY BARRIER	690	LF	\$	\$
4	104 18	INLET PROTECTION SYSTEM	51	EA	\$	\$
5	110 1 1	CLEARING AND GRUBBING	12.47	AC	\$	\$
6	110 4 10	REMOVAL OF EXISTING CONCRETE	2018	SY	\$	\$
General Sub-Total						\$
Roadway						
7	120 1	REGULAR EXCAVATION	3560	CY	\$	\$
8	120 6	EMBANKMENT	21194	CY	\$	\$
9	160 4	TYPE B STABILIZATION	40728	SY	\$	\$
10	285 711	OPTIONAL BASE GROUP 11, 12" LIMEROCK	36118	SY	\$	\$
11	327 70 6	MILLING EXISTING ASPHALT PAVEMENT, 1 1/2" AVG DEPTH	5,217	SY	\$	\$
12	334 1 12	SUPERPAVE ASPHALT PAVEMENT, TRAFFIC B (3")	5,960	TN	\$	\$
13	337 7 80	ASPHALT CONCRETE FRICTION COURSE, TRAFFIC B, FC-9.5, PG 76-22 (1.5")	3,410	TN	\$	\$
14	520 1 10	CONCRETE CURB & GUTTER, TYPE F	9,005.00	LF	\$	\$
15	520 5 41	TRAFFIC SEPARATOR CONCRETE - TYPE IV, 4' WIDE	1,396.00	LF	\$	\$
16	522 1	CONCRETE SIDEWALK AND DRIVEWAYS, 4" THICK	3,252	SY	\$	\$
17	522 2	CONCRETE SIDEWALK AND DRIVEWAYS, 6" THICK	729	SY	\$	\$
18	527 2	DETECTABLE WARNINGS	337	SF	\$	\$
19	570 1 1	PERFORMANCE TURF	13,990	SY	\$	\$
20	570 1 2	PERFORMANCE TURF, SOD	6,012	SY	\$	\$
Roadway Sub-Total						\$
Drainage						
21	425 1 311	INLETS, CURB, TYPE P-1, <10'	9.00	EA	\$	\$
22	425 1 315	INLETS, CURB, TYPE P-1, PARTIAL	2.00	EA	\$	\$
23	425 1 321	INLETS, CURB, TYPE P-2, <10'	7.00	EA	\$	\$
24	425 1 411	INLETS, CURB, TYPE J-1, <10'	2.00	EA	\$	\$
25	425 1 412	INLETS, CURB, TYPE J-1, >10'	4.00	EA	\$	\$
26	425 1 421	INLETS, CURB, TYPE J-2, <10'	6.00	EA	\$	\$

27	425 1 471	INLETS, CURB, TYPE 7, <10'	5.00	EA	\$	\$
28	425 1 521	INLETS, DT BOT, TYPE C, <10'	2.00	EA	\$	\$
29	425 1 541	INLETS, DT BOT, TYPE D, <10'	5.00	EA	\$	\$
30	425 2 61	MANHOLES, P-8, <10'	1.00	EA	\$	\$
31	425 2 92	MANHOLES, J-8, >10'	5.00	EA	\$	\$
32	430 175 118	PIPE CULVERT, OPTIONAL MATERIAL, ROUND 18"	1,318.00	LF	\$	\$
33	430 175 124	PIPE CULVERT, OPTIONAL MATERIAL, ROUND 24"	274.00	LF	\$	\$
34	430 175 130	PIPE CULVERT, OPTIONAL MATERIAL, ROUND 30"	476.00	LF	\$	\$
35	430 175 136	PIPE CULVERT, OPTIONAL MATERIAL, ROUND 36"	746.00	LF	\$	\$
36	430 175 142	PIPE CULVERT, OPTIONAL MATERIAL, ROUND 42"	843.00	LF	\$	\$
37	430 175 148	PIPE CULVERT, OPTIONAL MATERIAL, ROUND 48"	855.00	LF	\$	\$
38	430 174 218	PIPE CULVERT, OPTIONAL MATERIAL, OTHER SHAPE, ELLIP/ARCH, 18"	442.00	LF	\$	\$
39	430 174 224	PIPE CULVERT, OPTIONAL MATERIAL, OTHER SHAPE, ELLIP/ARCH, 24"*	322.00	LF	\$	\$
40	430 530 100	STRIAGHT CONCRETE ENDWALL, 30", SINGLE, 0 DEG, ROUND	2.00	EA	\$	\$
41	430 984 625	MITERED END SECTION, OPTIONAL - ELLIP/ARCH, 18"	6.00	EA	\$	\$
42	430 984 629	MITERED END SECTION, OPTIONAL - ELLIP/ARCH, 24"	2.00	EA	\$	\$
Drainage Sub-total						\$
Signing and Pavement Marking						
43	700 1 11	SINGLE POST SIGN, F&I GROUND MOUNT, UP TO 12 SF	9.00	AS	\$	\$
44	700 1 12	SINGLE POST SIGN, F&I GROUND MOUNT, 12-20 SF	1.00	AS	\$	\$
45	700 1 50	SINGLE POST SIGN, RELOCATE	1.00	AS	\$	\$
46	700 1 60	SINGLE POST SIGN, REMOVE	14.00	AS	\$	\$
47	705 11 1	DELINEATOR, FLEXIBLE TUBULAR	5.00	EA	\$	\$
48	706 1 3	RAISED PAVEMENT MARKER, TYPE B	721.00	EA	\$	\$
49	711 11 102	THERMOPLASTIC, STANDARD, WHITE, SOLID 8"	0.08	GM	\$	\$
50	711 11 123	THERMOPLASTIC, STANDARD, WHITE, SOLID 12"	1,417.00	LF	\$	\$
51	711 11 124	THERMOPLASTIC, STANDARD, WHITE, SOLID 18"	513.00	LF	\$	\$
52	711 11 125	THERMOPLASTIC, STANDARD, WHITE, SOLID 24"	313.00	LF	\$	\$
53	711 11 141	THERMOPLASTIC, STANDARD, WHITE, 2-4 DOTTED GUIDELINE, 6"	0.16	GM	\$	\$

54	711 11 160	THERMOPLASTIC, PREFORMED, WHITE, MESSAGE	18.00	EA	\$	\$
55	711 11 170	THERMOPLASTIC, PREFORMED, WHITE, ARROW	64.00	EA	\$	\$
56	711 11 224	THERMOPLASTIC, STANDARD, YELLOW, SOLID 18"	170.00	LF	\$	\$
57	711 15 101	THERMOPLASTIC, STANDARD OG ASPHALT, WHITE, SOLID, 6"	2.63	GM	\$	\$
58	711 15 131	THERMOPLASTIC, STANDARD OG ASPHALT, WHITE, SKIP, 6" 10-30 SKIP	1.92	GM	\$	\$
59	711 15 201	THERMOPLASTIC, STANDARD OG ASPHALT, YELLOW, SOLID, 6"	1.45	GM	\$	\$
Signing and Pavement Marking Sub-Total						\$
Total Lump Sum Bid Price						\$

BID NO: 23-94; CR 210 Widening from Trinity Way to Beachwalk Boulevard

BID BOND

STATE OF FLORIDA
COUNTY OF ST. JOHNS

KNOW ALL MEN BY THESE PRESENTS, that _____ as Principal, and _____ as Surety, are held and firmly bound unto St. Johns County, Florida, in the penal sum of _____ Dollars (\$ _____) lawful money of the United States, we bind ourselves, our heirs, executors, administrators, and successors, jointly and severally, firmly by these presents.

THE CONDITION OF THIS OBLIGATIONS IS SUCH that whereas the Principal has submitted the accompanying Bid, dated , 20__.

For
CR 210 Widening from Trinity Way to Beachwalk Boulevard
St. Johns County, Florida

NOW THEREFORE,

- (a) If the Principal shall not withdraw said Bid within ninety (90) days after Bid Award date, and shall within ten (10) days after prescribed forms are presented to him for signature, enter into a written Contract with the County in accordance with the Bid as accepted, and give Bond with good and sufficient Surety or Sureties, as may be required, for the faithful performance and proper fulfillment of such Contract, then the above obligations shall be void and of no effect, otherwise to remain in full force and virtue.
- (b) In the event of the withdrawal of said Bid within the period specified, or the failure to enter into such Contract and give such Bond within the time specified, if the Principal shall pay the County the difference between the amount specified, in said Bid and the amount for which the County may procure the required Work and supplies, if the latter amount be in excess of the former, then the above obligations shall be void and of no effect, otherwise to remain in full force and virtue.

IN WITNESS WHEREOF, the above bounded parties have executed this instrument under their several seals, this day of _____ A.D., 20__, the name and corporate seal of each corporate party being hereto affixed and these presents duly signed by its undersigned representative, pursuant to authority of its governing body.

BID NO: 23-94; CR 210 Widening from Trinity Way to Beachwalk Boulevard

WITNESSES:

(If Sole Ownership or Partnership two (2) Witnesses required).
(If Corporation, Secretary only will attest and affix seal).

WITNESSES:

PRINCIPAL:

NAME OF FIRM:

SIGNATURE OF AUTHORIZED
OFFICER (AFFIX SEAL)

TITLE

BUSINESS ADDRESS

CITY STATE

WITNESS:

SURETY:

CORPORATE SURETY

ATTORNEY-IN-FACT (AFFIX SEAL)

BUSINESS ADDRESS

CITY STATE

NAME OF LOCAL INSURANCE AGENCY

SEALED BID MAILING LABEL

**Cut along the outer border and affix this label
to your sealed bid envelope to identify it as a
"Sealed BID"**

SEALED BID • DO NOT OPEN	
SEALED BID NO.:	BID NO: 23-94
BID TITLE:	CR 210 Widening from Trinity Way to Beachwalk Boulevard
DUE DATE/TIME:	By 2:00PM – October 11, 2023
SUBMITTED BY:	Company Name
	Company Address
	Company Address
DELIVER TO:	St. Johns County Purchasing Division 500 San Sebastian View St. Augustine FL 32084



END OF DOCUMENT